

---

PRACTICAL ZOOLOGY

# VERTEBRATE

---

S.S. LAL



---

PRACTICAL ZOOLOGY  
**VERTEBRATE**

---



---

**DR. S. S. LAL**  
*FORMERLY, PROFESSOR AND HEAD*  
*DEPARTMENT OF ZOOLOGY*  
**INSTITUTE OF ADVANCED STUDIES**  
**C. C. S. MEERUT UNIVERSITY**  
**MEERUT**

---



**RASTOGI**  
**PUBLICATIONS**

'GANGOTRI', SHIVAJI ROAD, MEERUT-250 002, INDIA

**PRACTICAL ZOOLOGY**  
**VERTEBRATE**

"This page is Intentionally Left Blank"

**PRACTICAL ZOOLOGY  
VERTEBRATE**

ISBN 978-81-7133-925-9

**© RESERVED**

*All rights reserved. No part of this book (any edition/reprint) may be produced, stored in a retrieval system or transmitted in any form what so ever or by any means electronically or mechanically or by photocopying, recording or otherwise without the prior written permission of the Publisher. Infringement of copyright is a criminal offence.*

TITLE CODE NO. **Z-21**

**Revised Edition : 2009-2010**

PUBLISHED BY RAKESH KUMAR RASTOGI FOR RASTOGI  
PUBLICATIONS, 'GANGOTRI' SHIVAJI ROAD, MEERUT-250 002  
PHONES : (0121) 2510688, 2515142, 2516080, FAX 0121-2521545  
email : sales@rastogipublication.com Website:www.rastogipublications.com  
PRINTED AT CAPITAL OFFSET PRESS, NEW DELHI, INDIA

"This page is Intentionally Left Blank"

# Contents

*Chapters*

*Page No.*

## 1. Introduction to Phylum Chordata

1-4

Characters (1)

Outline Classification of Chordates (2)

Classification flow chart (3)

Types of Practical Work (4).

## 2. Study of Museum Specimens

5-180

### **Museology (5)**

Collection (5)

Preservation (6)

Collection and Preservation in Chordate  
Groups (6)

Arrangement and Care of Specimens in  
Museum (7)

Instructions to Draw Museum  
Specimens (7)

### **Sub-phylum I. Hemichordata (8)**

Natural history (8)

Classification (8)

1. *Balanoglossus* (8)

2. *Saccoglossus* (9)

3. *Rhabdopleura* (10)

4. *Cephalodiscus* (11)

### **Sub-phylum II. Urochordata (13)**

Natural history (13)

Classification (13)

5. *Ascidia* (13)

6. *Ciona* (14)

7. *Herdmania* (15)

8. *Pyrosoma* (16)

9. *Doliolum* (18)

10. *Salpa* (19)

11. *Oikopleura* (20)

### **Sub-phylum III. Cephalochordata (21)**

Natural history (21)

Classification (21)

12. *Amphioxus* (22)



**Sub-phylum IV. Vertebrata****Class—Cyclostomata (23)**

- 13. *Petromyzon* (23)
- 14. *Myxine* (24)
- 15. *Bdellostoma* (25)

**Super Class Pisces (= Fishes) (26)**

Classification with flow chart (26)

**Class 1. Placodermi : Extinct fishes (26)**

Flow chart (28)

**Class 2. Chondrichthyes : Cartilaginous Fishes (29)**

- 16. *Scoliodon* (29)
- 17. *Scoliodon* : Embryo with Yolk Sac Placenta (31)
- 18. *Chiloscyllium* (31)
- 19. *Stegostoma* (32)
- 20. *Sphyrna* (33)
- 21. *Torpedo* (34)
- 22. *Pristis* (35)
- 23. *Rhinobatus* (36)
- 24. *Raja* (37)
- 25. *Trygon* (38)
- 26. *Myliobatis* (39)
- 27. *Chimaera* (40)

**Class 3. Osteichthyes : Bony Fishes and Lung Fishes****Bony Fishes (42)**

- Natural history (42)
- 28. *Polypterus* (42)
- 29. *Polyodon* (43)
- 30. *Acipenser* (44)
- 31. *Amia calva* (45)
- 32. *Lepidosteus* (46)
- 33. *Salmo sola* (47)
- 34. *Esox lucius* (48)
- 35. *Notopterus* (49)
- 36. *Labeo rohita* (50)
- 37. *Clarius* : Mangur (51)
- 38. *Wallago attu* (52)
- 39. *Barbus sarana* (52)
- 40. *Ophiocephalus punctatus* (53)
- 41. *Anguilla vulgaris* (54)
- 42. *Amphipnous cuchia* (55)
- 43. *Pterois* (56)
- 44. *Anabas* (57)
- 45. *Exocoetus* (58)
- 46. *Syngnathus* (59)
- 47. *Hippocampus* (59)

- 48. *Echeneis* (60)
- 49. *Pleuronectes* (61)
- 50. *Lophius* (62)
- 51. *Tetradon* (63)
- 52. *Diodon* (64)
- 53. *Ostracion* (65)

**Class 3. Osteichthyes :****–Lung Fishes (66)**

Natural history (66)

- 54. *Protopterus* (66)
- 55. *Lepidosiren paradoxa* (67)
- 56. *Neoceratodus porsteri* (68)

**Class : Amphibia (70)**

Natural History (70)

Classification with flow chart (70)

- 57. *Ichthyophis* (72)
- 58. *Uraeotyphlus* (74)
- 59. *Necturus* (74)
- 60. *Proteus* (75)
- 61. *Cryptobranchus* (76)
- 62. *Ambystoma maculatum* (77)
- 63. Axolotl Larva (78)
- 64. *Salamandra* (78)
- 65. *Triturus cristatus* (79)
- 66. *Amphiuma* (80)
- 67. *Siren* (81)
- 68. *Bombinator* (82)
- 69. *Alytes* (82)
- 70. *Pipa* (83)
- 71. *Bufo* (84)
- 72. *Hyla* (85)
- 73. *Rhacophorus* (86)

**Class : Reptilia (87)**

Natural history (87)

Classification with flow chart (87)

- 74. *Testudo* (90)
- 75. *Chrysemys* (91)
- 76. *Kachuga tatum* (91)
- 77. *Chelone* (92)
- 78. *Trionyx* (93)
- 79. *Sphenodon* (94)
- 80. *Hemidactylus* (95)
- 81. *Gecko* (96)
- 82. *Phrynosoma* (97)
- 83. *Iguana* (98)
- 84. *Crotaphytus* (99)
- 85. *Draco* (100)
- 86. *Moloch* (101)

- 87. *Calotes* (102)
- 88. *Mabuia* (102)
- 89. *Chamaeleon* (103)
- 90. *Varanus* (104)
- 91. *Heloderma* (105)
- 92. *Ophiosaurus* (106)

**Snakes (107)**

- 93. *Typhlops* (108)
- 94. *Python* (109)
- 95. *Eryx* (110)
- 96. *Ptyas* (111)
- 97. *Natrix* (111)
- 98. *Dendrophis* (112)
- 99. *Hydrophis* (112)
- 100. *Crotalus* (113)
- 101. *Vipera* (114)
- 102. *Ancistrodon* (115)
- 103. *Bungarus* (116)
- 104. *Naja naja* (117)
- 105. *Crocodylus* (118)
- 106. *Alligator* (119)
- 107. *Gavialis* (119)

**Extinct Reptiles (Dinosaurs) :****Models (121)**

- 108. *Ichthyosaurus* (121)
- 109. *Dimetrodon* (121)
- 110. *Brontosaurus* (122)
- 111. *Diplodocus* (123)
- 112. *Tyrannosaurus* (124)
- 113. *Iguanodon* (124)
- 114. *Stegosaurus* (125)
- 115. *Rhamphorhynchus* (126)
- 116. *Pteranodon* (127)

**Class Aves (Birds) (128)**

Natural history (128)

Classification with flow chart (128)

- 117. *Phoenicopterus* (131)
- 118. *Gyps bengalensis* (132)
- 119. *Pavo cristatus* (133)
- 120. *Columba livia* (134)
- 121. *Psittacula euparia* (135)
- 122. *Bubo bubo* (136)
- 123. *Eudynamis scolopaceus* (137)
- 124. *Dendrocopus* (138)
- 125. *Passer domesticus* (138)
- 126. *Corvus splendens* (139)
- 127. *Archaeopteryx lithographica* (140)

- 128. Types of Beaks in Birds 142
- 129. Types of Feet or Claws in Birds (144)

**Class : Mammalia (146)**

Natural history (146)

Classification with flow chart (146)

- 130. *Ornithorhynchus* (149)
- 131. *Echidna* = *Tachyglossus* (150)
- 132. *Macropus* (151)
- 133. *Erinaceus* (151)
- 134. *Talpa* (152)
- 135. *Sorex* (153)
- 136. *Loris* (154)
- 137. *Pteropus* = *Cynopterus* (155)
- 138. *Dasypus* (156)
- 139. *Manis* (156)
- 140. *Macaca mulata* (157)
- 141. *Hylobates* (158)
- 142. *Pan triglodytes* (158)
- 143. *Pongo* (159)
- 144. *Gorilla* (160)
- 145. *Homo sapiens* (161)
- 146. *Oryctolagus* (161)
- 147. *Lepus* (162)
- 148. *Funambulus* (163)
- 149. *Rattus rattus* (164)
- 150. *Hystrix* (164)
- 151. *Lutra* (165)
- 152. *Herpestes* (166)
- 153. *Felis domesticus* (166)
- 154. *Felis leo* (167)
- 155. *Canis familiaris* (168)
- 156. *Malurus ursinus* (169)
- 157. *Acinonyx jubatus* (169)
- 158. *Hyaena* (170)
- 159. *Phoca* (171)
- 160. *Platanista gangeticus* (171)
- 161. *Elephas maximus* (172)
- 162. *Equus caballus* (173)
- 163. *Equus zebra* (174)
- 164. *Equus hemionus* (175)
- 165. *Rhinoceros* (176)
- 166. *Camelus dromedarius* (176)
- 167. *Sus scrofa* : Pig (177)
- 168. *Giraffa camelopardalis* (178)
- 169. *Ovibos moschatus* (179)
- 170. *Ovis* (179)
- 171. *Moschus moschiferous* (180)

### 3. Wonder Vertebrate Animals 181–183

Fishes, Amphibians, Reptiles, Birds,

Mammals, Carnivores, Chiroptera and Primates.

### 4. Preparation of Fixatives, Stains and Other Reagents 184–187

### 5. General Method of Microscopic Preparations 188–190

#### Microscopic Preparations of Slides

1. Killing and narcotization (188)
2. Fixing (189)
3. Washing (189)
4. Staining (189)
5. De-staining (189)

6. Dehydration (189)
7. De-alcoholization or clearing (189)
8. Mounting on slides (190)
9. Labelling (190)
- Charts for single and double staining (190)

### 6. Microtomy 191–193

1. Animals and tissues for microtomy (191)
2. Narcotization of animals (191)
3. Fixing of tissues (191)
4. Washing of tissues (192)
5. Dehydration of tissues (192)
6. De-alcoholization or clearing of tissues (192)

7. Embedding of tissues (192)
8. Block making (192)
9. Trimming of blocks (192)
10. Section cutting (192)
11. Double staining, dehydration, clearing and mounting (192)
12. Microscopic study (193)
13. Microphotography (193)

### 7. Preparations of Permanent Stained Slides (Mountings) 194–205

Instructions for Permanent Mountings

#### A. Protochordates (194)

1. *Salpa*, *Doliolum* and *Amphioxus* : Whole Mount (195)
2. *Amphioxus* : Oral Hood (196)
3. *Amphioxus* : Velum (196)
4. *Amphioxus* : Pharyngeal Wall (197)
5. *Herdmania* : Neural Complex (197)
6. *Herdmania* : Spicules (197)
7. *Herdmania* : Pharyngeal wall (198)

#### B. Fishes (199)

8. *Scoliodon* : Ampullae of Lorenzini (199)
9. *Scoliodon* : Placoid Scales (199)

10. *Labeo* : Cycloid Scales (200)
11. *Nandus* : Ctenoid Scales (200)
12. *Lepidosteus* : Rhomboid Scales (200)

#### C. Amphibia (201)

13. Frog : Blood (201)
14. Frog : Squamous Epithelium (201)
15. Frog : Ciliated Epithelium (201)
16. Frog : Columnar Epithelium (202)
17. Frog : Striated or Striped Muscle Fibres (202)
18. Frog : Unstriated or Unstriped (202)
19. Frog : Columella Awis (202)
20. Frog : T.S. Passing Through a Cranium Cartilage (202)

21. Nerve Fibres :  
Medullated Non-Medullated (203)

**D. Birds**

22. Pigeon : Blood (204)  
23. Pigeon : Pecten (204)

24. Pigeon : V.S of Eye Showing  
Position of Pecten (204)  
25. Pigeon : Filoplume (205)

**E. Mammals**

26. Rat : Blood (205)

**8. Study of Histological Slides**

206–264

Instructions for the Study of Slides (206)

**A. Protochordates (206)**

1. *Herdmania* : Metamorphosis : Tadpole Larva (206)
2. *Herdmania* : Neural Complex (208)
3. *Herdmania* : Various Spicules (209)
4. *Amphioxus* : V.L.S. of Anterior Region (210)
5. *Amphioxus* : T.S. Passing Through Oral Hood (210)
6. *Amphioxus* : T.S. Passing Through Pharynx (211)
7. *Amphioxus* : T.S. Passing Through Ovaries (212)
8. *Amphioxus* : T.S. Passing Through Testes (213)
9. *Amphioxus* : T.S. Passing Through Mid-gut or Intestine (214)
10. *Amphioxus* : T.S. Passing Through Atriopore (215)
11. *Amphioxus* : T.S. Passing Through Anal Region (216)
12. *Amphioxus* : T.S. Passing Through Caudal Region (217)

**B. Cyclostomata**

13. Lamprey : Ammocoete Larva : Whole Mount (218)
14. Lamprey : Ammocoete Larva : T.S. Passing Through Branchial Region (218)
15. Lamprey : Ammocoete Larva : T.S. Passing Through Intestine (219)
16. *Petromyzon* : T.S. Passing Through Branchial Region (220)
17. *Petromyzon* : T.S. Passing Through Trunk Region (221)
18. *Petromyzon* : T.S. Passing Through Tail Region (221)

**C. Fishes**

19. *Scoliodon* : Hand Cut T.S. Passing Through Eye Region (222)
20. *Scoliodon* : Hand Cut T.S. Passing Through Olfactory Region (222)
21. *Scoliodon* : Hand Cut T.S. Passing Through Branchial Region (223)
22. *Scoliodon* : Hand Cut T.S. Passing Through Stomach and Liver Region (224)
23. *Scoliodon* : Hand Cut T.S. Passing Through Intestinal Region (225)
24. *Scoliodon* : Hand Cut T.S. Passing Through Base of Pelvic Fin of Male and Female (226)
25. *Scoliodon* : Hand Cut T.S. Passing Through Caudal Region (227)
26. *Labeo rohita* : Cycloid Scales (227)
27. *Nandus* : Ctenoid Scales (228)
28. *Scoliodon* : Placoid Scales (228)
29. *Scoliodon* : Development of Placoid Scales (229)
30. *Polypterus* : Ganoid Scales (230)

**D. Amphibia**

31. Frog : V.S. of Skin (230)
32. Frog : T.S. Passing Through Stomach (231)
33. Frog : T.S. Passing Through Duodenum (232)
34. Frog : T.S. Passing Through Intestine (233)
35. Frog : T.S. Passing Through Liver (235)
36. Frog : T.S. Passing Through Pancreas (236)
37. Frog : T.S. Passing Through Spleen (237)
38. Frog : T.S. Passing Through Lung (237)

39. Frog : T.S. Passing Through Spinal Cord (238)
40. Frog : T.S. Passing Through Kidney (239)
41. Frog : T.S. Passing Through Testis (240)
42. Frog : T.S. Passing Through Ovary (241)
43. Frog : T.S. Passing Through Bone (242)
- E. Reptile**
44. Lizard : V.S. of Skin (243)
45. Lizard : V.S. of Lung (243)
- F. Bird**
46. Bird : V.S. of Skin (244)
47. Pigeon : Development of Down and Contour Feathers (245)
48. Pigeon : L.S. of Crop (246)
49. Pigeon : V.L.S. of Proventriculus (246)
50. Pigeon : T.S. Passing Through Hand Cut Section of Gizzard (246)
- G. Mammalia**
51. Rabbit : V.S. of Skin (247)
52. Rabbit : T.S. Passing Through Cardiac Stomach (248)
53. Rabbit : T.S. Passing Through Ileum (249)
54. Rabbit : T.S. Passing Through Liver (250)
55. Rabbit : T.S. Passing Through Pancreas (251)
56. Rabbit : T.S. Passing Through Spleen (252)
57. Rabbit : T.S. Passing Through Thyroid Gland (253)
58. Rabbit : T.S. Passing Through Parathyroid Gland (254)
59. Rabbit : T.S. Passing Through Adrenal Gland (255)
60. Rabbit : T.S. Passing Through Lung (256)
61. Rabbit : L.S. Passing Through Kidney (257)
62. Rabbit : T.S. Passing Through Testis (258)
63. Rabbit : T.S. Passing Through Ovary (259)
64. Rabbit : T.S. Passing Through Bone (260)
65. Rabbit : T.S. Passing Through Placenta (260)
66. Rabbit : T.S. Passing Through Spinal Cord (261)
- H. Study of Photographs of Animal Tissues**
67. Simple Cuboidal Epithelium (261)
68. Simple Columnar Epithelium (262)
69. Goblet Cells (262)
70. Adipose Tissue (262)
71. Reticular Tissues (263)
72. Blood Smear of Frog (263)
73. Blood Smear of Rabbit (263)
74. Frog : T.S. Passing Through Testis (264)
75. Frog : T.S. Passing Through Ovary (264).

## 9. Study of Embryological Slides

265–283

### **Spermatogenesis (265)**

1. Rabbit : T. S. Passing Through Testis and Spermatogenesis (265)

### **Oogenesis (267)**

2. Rabbit : T. S. Passing Through Ovary and Oogenesis (267)
3. Study of Fertilization Through a Model Diagram (268)

### **Development of Frog (269)**

4. Frog : Structure of Ovum (269)

5. Frog : V.S. Passing Through Blastula (269)
6. Frog : V.S. Passing Through Gastrula (270)
7. Frog : Tadpole Larva : Whole Mount (270)
8. Frog : Tadpole T.S. Passing Through Eyes (271)
9. Frog : Early Tadpole T.S. Passing Through Ears (271)

**Development of Chick (272)**

10. Chick Embryo : Whole Mount of 4 Hours of Incubation (272)
11. Chick Embryo : Whole Mount of 16 Hours of Incubation (273)
12. Chick Embryo : L.S. of 17 Hours of Incubation (273)
13. Chick Embryo : Whole Mount of 18 Hours of Incubation (273)
14. Chick Embryo : L.S. of 18 Hours of Incubation (274)
15. Chick Embryo : Whole Mount of 24 Hours of Incubation (275)
16. Chick Embryo : T.S. Passing Through 24 Hours of Incubation (276)
17. Chick Embryo : Whole Mount of 28 Hours of Incubation (276)
18. Chick Embryo : T.S. Passing Through 28 Hours of Incubation (277)
19. Chick Embryo : Whole Mount of 33 Hours of Incubation (278)

20. Chick Embryo : T.S. Passing Through 33 Hours of Incubation (279)
21. Chick Embryo : Whole Mount of 43 Hours of Incubation (279)
22. Chick Embryo : Whole Mount of 72 Hours of Incubation (280)

**Chick Embryo : Preserved (281)**

23. Chick Embryo : Three Days Old Formalin Preserved Whole Embryo from Ventral Side (281)
24. Chick Embryo : 6 Days Old Formalin Preserved Whole Embryo from Dorsal Side (282)
25. Chick Embryo : 12 Days Old Formalin Preserved Whole Embryo from Dorsal Side (282)
26. Chick Embryo : 18 Days Old Formalin Preserved Whole Embryo from Dorsolateral Side (283)
27. Chick Embryo : 21 Days Just Hatched Chick (283)

**10. Comparative Osteology = Study of Bones**

284–326

## Division of Endoskeleton

## Osteological Terms

***Scoliodon* : Endoskeleton (Osteology)**

1. *Scoliodon* : Skull (286)
2. *Scoliodon* : Vertebral Column (287)
3. *Scoliodon* : Pectoral Girdle and Fins (288)
4. *Scoliodon* : Pelvic Girdle and Fins (288)

**Skull Bones (289)**

1. Skull of Frog (289)
2. Skull of Rabbit (289)
3. Skull of *Varanus* (292)
4. Skull of Fowl (292)

**Disarticulated Skull Bones (296)**

1. Disarticulated Skull Bones of Frog (296)
2. Disarticulated Skull Bones of Rabbit (298)
3. Disarticulated Skull Bones of *Varanus* (300)
4. Disarticulated Skull Bones of Fowl (303)

**Lower Jaws or Mandibles (304)**

1. Lower Jaw or Mandible of Frog (304)
2. Lower Jaw or Mandible of *Varanus* (304)
3. Lower Jaw or Mandible of Fowl (306)
4. Lower Jaw or Mandible of Rabbit (306)

**Bones of Vertebral Column (307)**

1. Vertebrae of Frog (307)
2. Vertebrae of *Varanus* (308)
3. Vertebrae of Fowl (310)
4. Vertebrae of Rabbit (312)

**Ribs (314)**

1. Thoracic Rib of *Varanus* (314)
2. Thoracic Rib of Fowl (314)
3. Thoracic Rib of Rabbit (315)

**Pectoral Girdles (316)**

1. Pectoral Girdle and Sternum of Frog (316)
2. Pectoral Girdle of *Varanus* (316)
3. Pectoral Girdle of Fowl (317)
4. Pectoral Girdle of Rabbit (318)

**Pelvic Girdles (318)**

1. Pelvic Girdle of Frog (318)
2. Pelvic Girdle of *Varanus* : Left Innominate : Lateral View (318)
3. Pelvic Girdle of Fowl : Outer View (319)
4. Pelvic Girdle of Rabbit : Left Half : Lateral View (320)

**Forelimb Bones (320)**

1. Forelimb Bones of Frog (320)

2. Forelimb Bones of *Varanus* (321)
3. Forelimb Bones of Fowl (321)
4. Forelimb Bones of Rabbit (322)

**Hind Limb Bones (323)**

1. Hind Limb Bones of Frog (323)
2. Hind Limb Bones of *Varanus* (324)
3. Hind Limb Bones of Fowl (324)
4. Hind Limb Bones of Rabbit (325)

**11. Dissections (Major and Minor)**

327–372

General Instructions for Dissection (327)

***Scoliodon* : Dogfish**

1. *Scoliodon* : External Features (328)
2. *Scoliodon* : General Anatomy (330)
3. *Scoliodon* : Heart and Afferent Branchial Arteries (332)
4. *Scoliodon* : Efferent Branchial Arteries (332)
5. *Scoliodon* : Eye Muscles (333)
6. *Scoliodon* : Internal Ear (333)
7. *Scoliodon* : Cranial Nerves (334)

**Frog's New Name : *Hoplobatrachus tigrinus*****Frog's Old Name : *Rana tigrina* (336)**

1. Frog : External Features (336)
2. Frog : Bucco-pharyngeal Cavity (337)
3. Frog : Muscular System (338)
4. Frog : General Anatomy (339)
5. Frog : Circulatory System (340)
6. Frog : Urinogenital System (344)
7. Frog : Cranial Nerves (346)

***Uromastix* : Lizard (347)**

1. Lizard : External Features (347)

2. Lizard : Arterial System (348)

3. Lizard : Venous System (350)

**Snake : Biting Mechanism in Viper (352)*****Columba livia domestica* :****Rock Pigeon (353)**

1. Rock Pigeon : External Features (353)
2. Rock Pigeon : General Anatomy (354)
3. Rock Pigeon : Flight Muscles (356)
4. Rock Pigeon : Venous System (357)
5. Rock Pigeon : Arterial System (359)

**Bird : Perching Mechanism (360)*****Rattus rattus* : Rat (361)**

1. Rat : External Features (361)
2. Rat : General Anatomy (363)
3. Rat : Venous System (363)
4. Rat : Arterial System (366)
5. Rat : Male Urinogenital System (368)
6. Rat : Female Urinogenital System (370)
7. Rat : Dissection of Muscles, Blood Vessels and Nerves of Neck Region (371)

**12. Experimental Biochemistry and Physiology**

373–407

**Experiments on Biochemistry (373)**

- Colour and Precipitation Reactions of Foodstuffs and Enzymes (373)
- Some Important Chemicals (374)
- Some Important Laboratory Reagents (374)
- Glass Apparatus (375)

**Biochemical Tests (375)**

1. Test on Carbohydrates (375)
  - A. Monosaccharides (375)
  - B. Experiments with Glucose and Fructose (375)
  - C. Disaccharides (376)

2. Test on Proteins (377)
  - A. Precipitation of Proteins with Heavy Metals (377)
 

*Experiments-1& 2*
  - B. Precipitation of Proteins by Alkaloid Reagents (377)
 

*Experiments 3 to 8*
  - C. Colour Reactions of Proteins (378)
3. Test on Fats and Oils (379)
 

*Experiments 1 to 4*
4. Test on Enzymes (380)
 

*Experiments 1 to 4*
5. General Experiments (382)

**Identification of Aminoacids, Amines, Peptides and Carbohydrates by Paper Chromatography (383)**

- Paper Chromatography for Amino Acids, Amines and Peptides (384)
- Class Experiment for Amino Acids Chromatography (385)
- Paper Chromatography for Carbohydrates (387)
- Class Experiment for Sugar Chromatography (388)

**Experiments on Physiology (389)**

**Muscle Contraction (389)**

- Non-electrical Parts (389)
- Electric Parts (389)
- Experiment (1) To Prepare Gastrocnemius muscle nerve (390)*
- Experiment (2) To Demonstrate or Draw*

- a Simple Muscle Curve (Simple Twitch) (391)
- Experiment (3) To Demonstrate the Phenomenon of Completed Tetanus (392)*
- Experiment (4) To Record the Heart Beats of the Frog in situ (392)*
- Experiment (5) : To Study the Effect of Adrenaline on the Heart Beat of Frog in situ by Perfusion Method (394)*

**Experiments of Blood, Blood Groups and Rh Factor (394)**

- R.B.C. Count (394)
- W.B.C. Count (396)
- Haemoglobin Percentage (396)
- Haemin Crystals (397)
- Human Blood Group (397)
- Rh Factor in Human Blood (398)
- Coagulation of Blood (400)
- Bleeding Time of Blood (400)
- Cloting Time of Blood (401)
- Blood Pressure of Man (401)
- Experiments of Urine Using Human Urine Sample (403)
- Oxygen Consumption in Albino or Black Rat (404)
- Rate of Oxygen Consumption in Albino Black Rat (405)
- Demonstration of Osmosis (406)
- Demonstration of Neurons by Bethylene Blue in Nerve Fibers (407)

---

## 13. Some Important Histochemical Tests

408–412

**Glycogen (408)**

1. PAS (Periodic Acid Schiffs) Technique (408)
2. Carmine Staining Technique (409)

**Lipids (410)**

- Sudan Black-B Staining for Lipids in Paraffin Sections (410)

**Proteins (411)**

- Mercury Bromophenol Blue Method for Proteins (411)

**Acid and Alkaline Phosphatases (411)**

1. Acid Phosphatase : The Lead Nitrate Method (411)
  2. Alkaline Phosphatase Method (411)
-



<b>14. Experimental Cytology</b>	<b>413–424</b>
<ul style="list-style-type: none"> <li>1. Prokaryotic and Eukaryotic Cells (413)</li> <li>2. Preparation of Chromosomes (416)</li> <li>3. Stages of Mitosis from Prepared Slides from Plant and Animal Materials (418)</li> <li>4. Stages of Meiosis from Prepared Slides from Plant and Animal Materials (419)</li> <li>5. Microphotographs of Certain Cell Organelles (421)</li> </ul>	
<hr/>	
<b>15. Study of <i>Drosophila</i> and Human Chromosomes</b>	<b>425–432</b>
<ul style="list-style-type: none"> <li>Study of <i>Drosophila</i> (425)</li> <li>Study of Human Chromosomes (431)</li> </ul>	
<hr/>	
<b>16. Experimental Ecology</b>	<b>433–440</b>
<ul style="list-style-type: none"> <li>Modification or Adaptation (433)</li> <li>Study of Biotic Factors (436)</li> <li>Study of Abiotic Factors (437)</li> <li>Analysis of Soil (440)</li> </ul>	
<hr/>	
<b>17. Experimental Endocrinology</b>	<b>441–451</b>
<ul style="list-style-type: none"> <li><b>Dissection of Endocrine Glands (441)</b></li> <li><b>Endocrine Glands : Location (443)</b></li> <li><b>Histology of Endocrine Glands (443)</b> <ul style="list-style-type: none"> <li>1. Rat : L.S. of Pituitary Gland (443)</li> <li>2. Rat : T.S. of Thyroid Gland (444)</li> <li>3. Rat : T. S. of Parathyroid Gland (445)</li> </ul> </li> <li>4. Rat : T.S. of Adrenal Gland (446)</li> <li>5. Rat : T.S. of Testis (447)</li> <li>6. Rat : T.S. of Ovary (448)</li> <li>7. Rat : T.S. of Pancreas (449)</li> <li>8. Chick : T.S. Passing Through Thymus Glands (450)</li> </ul>	
<hr/>	
<b>18. Practicals on Evolution and Animal Behaviour</b>	<b>452–477</b>
<ul style="list-style-type: none"> <li><b>Evolution</b> <ul style="list-style-type: none"> <li>A. Study of Evolution of Horse through Various Models (452)</li> <li>B. Study of Evolution through Homologous and Analogous Organs and Forms (456)</li> <li>C. Adaptive Modification of Feet or Claws in Birds (465)</li> <li>D. Adaptive Modification in Mouth Parts of Insects (467)</li> <li>E. Serial Homology (471)</li> </ul> </li> <li><b>Experiments on Animal Behaviour</b> <ul style="list-style-type: none"> <li>A. Study of Photographs (474)</li> <li>B. Phototaxis or Photoreception and Toxicological Responses (477)</li> </ul> </li> </ul>	
<hr/>	
<b>19. Viva Voce</b>	<b>478–484</b>

# Introduction to Phylum Chordata

# 1

**Phylum CHORDATA** (Gr., chorda, a string, or L., chordatus, a chord, *i.e.*, the **notochord**) is the largest of the **deuterostome phyla**. It is the highest and the most important phylum comprising a vast majority of animals living and extinct such as **tunicates, lancelets, lampreys, fishes, amphibians, reptiles, birds and mammals** including **man**.

## Characters

All chordates are **bilaterally symmetrical**, with **3 germ layers**, a **segmented body**, **complete alimentation** and a well-developed **coelom**. While groups of chordates differ widely from each other, they, however, possess three outstanding common characters which separate them from non-chordates. These **three fundamental** common chordate traits are as follows :

**1. Notochord** (Gr., **noton**, back; **chorde**, cord). It is a slender longitudinal stiff **skeletal rod** of connective tissue cells present just **dorsal to the**

**digestive tract**. It is this structure which gives the phylum its name. It furnishes support to the body and is not to be confused with the nerve cord. It persists throughout life in the lower chordates such as urochordates, cephalochordates and cyclostomes. But in the higher chordates (fishes to mammals) it is present only in the embryos and later replaced by the **vertebral column** which is made up of different **Vertebrae**.

**2. Hollow dorsal nerve chord**. A hollow or tubular nerve cord is present extending lengthwise of the body dorsal to the notochord. It arises as an infolding of the dorsal surface ectoderm of the embryo.

**3. Pharyngeal gill-clefts**. Paired lateral openings, commonly referred to as gill-clefts or gill-slits, develop on the sides of the embryonic pharynx, leading to outside. They persist in all lower chordates and serve for aquatic pharyngeal respiration. In **higher chordates** they soon close before hatching or birth as the adults of these animals develop lungs for breathing air.

## Expanded Classification of Chordata

Phylum Chordata is classified as follows :

### GROUP A. LOWER CHORDATA OR PROTOCHORDATA OR ACRANIATA

**Exclusively marine.** Mostly small-sized. Cephalization, cranium, brain and vertebral column absent. Notochord present.

#### Subphylum I. Hemichordata

Small soft bodied, marine enterocoelus coelomate creatures. Notochord confined to head region. Hemichordates are divided into 2 classes.

**Class 1. Enteropneusta.** Burrowing animal.

Ex. *Balanoglossus*, *Saccoglossus* and *Ptychodera*.

#### Subphylum II. Urochordata (Tunicata)

Typically short, thick-bodied, with a leathery covering called **test** or **tunic**. Notochord and nerve cord present only in larval tail.

**Class 1. Ascidiacea.** Tunic with scattered muscles. Many pharyngeal gill-slits.

Ex. *Herdmania*, *Ascidia*, *Ciona*.

**Class 2. Thaliacea.** Tunic with circular muscle bands.

Ex. *Pyrosoma*, *Doliolum*, *Salpa*.

**Class 3. Larvacea.** Minute. Tunic temporary. 2 gill-slits.

Ex. *Oikopleura*.

#### Subphylum III. Cephalochordata

Small, elongated, fish-like. Without paired fins. Notochord and nerve cord along entire body and persistent. Pharynx with numerous gill-slits.

**Class 1. Leptocardii.**

Ex. *Branchiostoma* (= *Amphioxus*).

**Class 2. Plerobranchie-Encased body**

Ex. *Rhabdopleura*, *Cephalodiscus*, *Atubaria*.

### GROUP B. HIGHER CHORDATA OR CRANIATA

**Small to large-sized**, head distinct with cranium, visceral arches, vertebrae and brain. The higher chordates include a single subphylum, the Vertebrata. Notochord broken into different vertebra.

#### Subphylum IV. Vertebrata

Small to very large. With marked cephalization. Brain enclosed in cranium. Notochord replaced partially or wholly by vertebral column.

#### Division I. Agnatha

No true jaws or paired appendages.

**Class 1. Ostracodermi.** Extinct fishes. Skin covered by large bony scales or plates.

Ex. *Cephalaspis*.

**Class 2. Cyclostomata.** Skin without scales. Mouth suctorial. Gills 5 to 16 pairs. Skeleton cartilaginous.

Ex. *Petromyzon*, *Myxine*, *Bdellostoma*.

#### Division II. Gnathostomata

With true jaws and paired appendages.

**Superclass 1. Pisces.** Paired fins, gills and skin with scales.

Ex. Fishes.

**Class 1. Placodermi.** Extinct fishes with primitive jaws.

**Class 2. Chondrichthyes.** Cartilaginous fishes. Skin with placoid scales. Gill-slits exposed, no operculum.

Ex. Sharks, rays and skates.

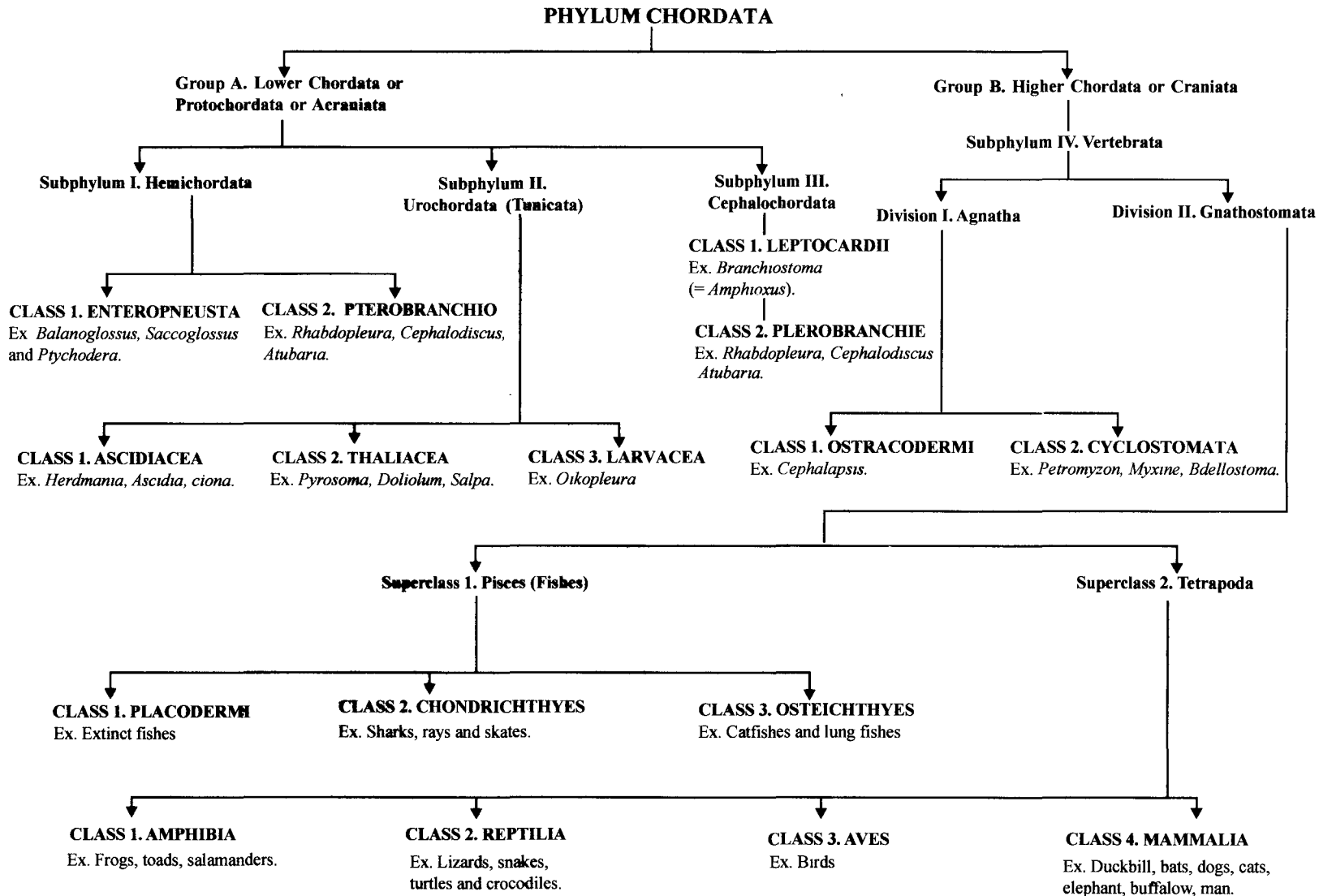

**Class 3. Osteichthyes.** Bony fishes. Skin with cycloid or ctenoid scales. Gill-slits covered by an operculum.

Ex. Perch, catfish, ganoids and lung-fishes.

**Superclass 2. Tetrapoda.** Paired limbs, lungs, cornified skin, and bony skeleton. Amphibious and terrestrial vertebrates.

**Class 1. Amphibia.** Skin moist, soft, glandular and without external scales. Cold-blooded.

Ex. Frogs, toads, salamanders.

**Class 2. Reptilia.** Skin dry, with external scales or scutes. Cold-blooded.

Ex. Lizards, snakes, turtles and crocodiles.

**Class 3. Aves.** Skin covered with feathers. Forelimbs form wings. Warm-blooded.

Ex. Birds.

**Class 4. Mammalia.** Skin covered with hairs. Females have milk glands to suckle young. Warm-blooded.

Ex. **Mammals**, such as **duckbill, bats, moles, dogs, cats, elephant, horse, lion, cow, monkey, buffalow and man.**

## Types of Practical Work

Practical work in Zoology helps to understand various aspects of animals both structurally and functionally. In most of the universities the practical work pertaining to Zoology includes :

- (1) Microscopic preparation of slides.
- (2) Mountings.
- (3) Culture of animals.
- (4) Study of prepared slides.
- (5) Study of museum specimens.
- (6) Major and minor dissections.
- (7) Experimental Biochemistry and Physiology.
- (8) Experimental Ecology.
- (9) Preparations of Fixatives and Stains.
- (10) Experimental Endocrinology.
- (11) Study of Embryological Slides.
- (12) Osteology.
- (13) Experimental Cytology.
- (14) Viva-voce.

# Study of Museum Specimens

## 2

### Museology

Chordates have countless animals. Only a few amongst many are studied as type specimens. The smaller animals are preserved wet in 5 to 10% formalin solution or in 90% alcohol while the larger animals are stuffed and kept dry in almost all museums of Zoology departments. The collection, preservation and maintenance of museum is called as **Museology**. Various specimens kept in a museum fall into following categories :

- (1) **Formalin preserved specimens in jars (Wet preservation).**
- (2) **Dry specimens (Dry preservation).**
- (3) **Stuffed animals (Taxidermy).**
- (4) **Mounted specimens (Dry preservation of skeleton, etc.).**

Before studying museum specimens, it is essential to know about collection and preservation of various specimens.

### Collection

Animals are collected in various ways such as :

**1. Catching by hand.** Small terrestrial and fresh-water animals can be caught with hands. Wear

post-mortem hand gloves while catching small animals.

**2. Netting.** Most of the aquatic animals (frogs, fishes, etc.) are collected by fine-meshed or coarse-meshed **nets**. Fishes of fresh-water and sea water are always collected by different kinds of nets.

**3. Digging and draining.** Most of the burrowing animals, like *Amphioxus*, can be collected by digging and draining or seiving the sand.

**4. Trapping.** For the small rodents and carnivores, different types of traps are employed. For instance, common house traps (**Chuhedan**) for house mouse. Traps may be steel traps, wooden traps and wonder traps. Keep some bait inside the trap. For example, in wonder traps for black rats, are kept small pellets (baits) made by mixing besan (gram flour) with musturd oil. In house traps for rats, small pieces of bread or chapati are kept.

**5. Shooting.** Specimens like snakes, birds, fast running rodents and carnivorous mammals are collected by shooting with a small gun or pistol. Collect these animals in bags made up of canvas cloth.

## Preservation

After collection, bring the animals to laboratory and preserve them either by **wet method** or **dry method**.

### [I] Wet preservation

The preservation of animals in formalin or 90% alcohol is called as **wet preservation**.

**1. Requirements.** Formalin, glycerine, chalk, copper sulphate, 90% alcohol, thread, rectangular glass plates, bakelite specimen jars of different sizes, glass jars of different sizes (100 cc, 250 cc, 500 cc, 5000 cc and 10,000 cc), wooden boards and printed labels.

**2. Procedure for wet preservation.** Prepare 5% formalin stock solution (100 cc of distilled water + 5 cc of formalin). Add 5 cc of glycerine. This formalin solution acts as a fixative as well as a preservative.

For preserving specimens, for example a living frog, first anaesthetize it with chloroform in a jar. When fully anaesthetized, wash and inject some 5% formalin solution into its thigh muscles and in thoracic region. Make a small slit in the abdomen and mount the frog on a glass plate with ventral side facing yourself. Tie the frog at forelimb and hind limb places. Transfer the mounted frog in a bakelite jar and fill it with 5% formalin solution. Close the mouth of jar with a glass plate and seal the cover of the mouth to prevent evaporation of formalin. Put a label depicting date of collection, place of collection and classification.

### [II] Dry preservation

Mostly birds and small rodents are preserved after drying them. Dry preservation can be done by two methods.

**1. Case-skin mount.** Good for small rodents such as rats. For example, take a black rat and anaesthetize it with chloroform. When fully anaesthetized, make a mid-ventral incision on abdomen and thorax and also mid-ventral incisions along both the limbs. Carefully remove the skin, treat it with borax solution and then spread over a wooden board. Stretch the skin, limbs and tail with dorsal surface facing you. Let the skin dry. Label the dried specimen.

**2. Taxidermy.** In this process, three-dimensional view is maintained by stuffing the animal with cotton or saw dust mixed with chalk

and copper sulphate. For example, take a living parrot and anaesthetize it with chloroform. When fully anaesthetized, keep it in a dissecting tray. Make a vertical incision along the mid-ventral abdominal axis and carefully remove internal organs. Remove muscles and bones of the fore and hind limbs. Fill the gap by packing it with cotton mixed with chalk and copper sulphate. Let the bird dry. Classify and label the specimen. The label must contain date of collection, place of collection and name of specimen. Let the specimen become completely dry and then keep it in museum.

Dried articulated and disarticulated skeletons, such as those of fish, frog, snake, *Varanus*, fowl, etc., are mounted on wooden board, with classification and labelling.

## Collection and Preservation in Chordate Groups

The process of collection and preservation is described in different chordate groups, as follows :

### [I] Urochordates

*Herdmania, Ascidia, Pyrosoma, etc.*

**1. Collection.** Sessile tunicates (*Herdmania*) can be collected by careful digging along the substratum. The pelagic tunicates (*Pyrosoma*) are collected by netting.

**2. Preservation.** By wet method. Wash the specimens in water and then transfer in glass jars containing 5% formalin solution. Seal, classify, write date of collection and place of collection.

### [II] Cephalochordates

*Amphioxus (= Branchiostoma)*

**1. Collection.** *Amphioxus* lives in sand, locate them by digging. Collect them by sieving the sand in coarse mesh sieve.

**2. Preservation.** By wet method.

### [III] Fishes

*Scoliodon, Labeo rohita, Hippocampus, etc.*

**1. Collection.** Both fresh-water and marine fishes can be collected by a variety of coarse mesh nets specially designed to catch fishes. Transfer them in a large container.

**2. Preservation.** By wet method as described earlier.

**[IV] Reptiles****Snakes, Wall lizard, Turtles, etc.**

**1. Collection.** Use canvas bags to collect reptiles. Snakes can be collected by expert snake catchers by hooked stick. Wall lizards can be collected by sudden pressing them with stick or towel and catching them by a large forceps. Collect small turtles by netting.

**2. Preservation.** Wet preservation. Procedure as described earlier in case of frog.

**[V] Birds****Parrot, Pigeon, Sparrow, Koel, etc.**

**1. Collection.** Collect birds by trapping and shooting with 0.410 shotgun in canvas collecting bags.

**2. Preservation.** Dry preservation by taxidermy as described earlier.

**[VI] Mammals**

Mammals comprise diversified groups. Favourite museum specimens are small rodents and carnivores such as mice, black rats, squirrels, weasels and shrews.

**1. Collection.** Collect mammals by steel traps, wonder traps (for Black rats) and mole traps.

**2. Preservation.** Dry mounting by case skin mount or taxidermy as described earlier. Label the specimen and keep in museum.

**Arrangement and****Care of Specimens in Museum**

- (1) Classify all the specimens.
- (2) Keep specimens in different shelves according to classification and type.

- (3) Regularly examine both wet and dry specimens.
- (4) In case of wet preservation, immediately replace formalin if it is lost.
- (5) Always use post-mortem gloves while collecting and preserving the specimens.
- (6) Keep exhaust fans on while working in museum.

**Instructions to****Draw Museum Specimens**

- (1) Before leaving home for Zoology practical laboratory, check that you are equipped with a Zoology practical exercise book, a text book of practical Zoology, H.B. pencil, pencil sharpener, pencil eraser (venus rubber) and a piece of soft cloth.
- (2) Try to obtain advance information about the museum specimens to be drawn so that you come prepared for their study.
- (3) Special care should be taken to give a very correct proportion about the dimensions (length and breadth) of the specimen.
- (4) Usually draw only 2 diagrams on one page, but these should be of the same class.
- (5) Classification should be written on the right top of the diagrams.
- (6) Line diagrams only should be drawn.
- (7) Shading should be avoided as far as possible.
- (8) Important features must be exhibited in the diagrams.
- (9) Each diagram must be fully labelled with the help of the book. The labelling should be horizontal.
- (10) Write both zoological and common names of each specimen below the diagram.



## SUBPHYLUM I. HEMICHORDATA

### Natural history

Hemichordates are small soft-bodied creatures, living singly or in group on sandy and muddy sea bottoms or in open water. The body and coelom are divided into three regions with paired gill-slits and nervous tissue in both dorsal and ventral epidermis. Certain tissue as an anterior projection from mouth cavity was formerly interpreted as a **notochord** and thus placing the group with **phylum Chordata**. Recent studies cast doubt on such interpretation and so-called **earlier notochord** is termed the **buccal pouch**. Now this group is placed under **independent phylum Hemichordata**. Between hemichordates and chordates there are resemblances in the pharyngeal gill-slits and the collar cord of the nervous system— its origin from dorsal epidermis. The embryo and early larvae of **hemichordates** and **asteroid**

**echinoderms** are much alike in ciliated bands, digestive tracts, form, derivation of anus from blastopore (deuterostome) and enterocoelous coelom. The above features strongly suggest a common origin.

### Classification

Phylum Hemichordata is divided into 2 classes :

**Class 1. Enteropneusta** – burrowing animals.

Ex. *Balanoglossus*, *Saccoglossus*, *Ptychodera*.

**Class 2. Pterobranchia** – encased body

**Order 1. Rhabdopleurida.**

Ex. *Rhabdopleura*.

**Order 2. Cephalodiscida.**

Ex. *Cephalodiscus*, *Atubaria*.

### 1. *Balanoglossus*

#### Classification :

Phylum.....	<b>Hemichordata</b>	→	Marine, enterocoelous coelomate. Notochord confined to head region.
Class.....	<b>Enteropneusta</b>	→	Several gill-slits, intestine straight, solitary.
Genus.....	(i) <i>Balanoglossus</i>	→	Acorn worm.
	(ii) <i>Glossobalanus</i>		(Tongue worm)

**Geographical distribution :** World-wide or cosmopolitan.

**Habit and habitat :** It is a marine animal, adapted for burrowing life in the sandy bottom. The animal lives inside the U-tubes (tubicolous). Most of them live in shallow water but a few go deeper upto approximately 15,000 feet. They burrow slowly by soft proboscis.

#### Comments :

- (1) *Balanoglossus* is commonly called as 'Acorn worm.' It lives in a U-shaped burrow and at one opening of burrow fecal castings may be seen. U-tube burrow at other end has opening for anterior end and also another additional opening.
- (2) It measures 10 cm to 2.5 meters, depending on the species.
- (3) It is bilaterally symmetrical, **triploblastic deuterostome** with worm-shaped body divisible into three regions—**anterior proboscis** or **prosoma**, **middle collar** or **mesosoma** and **posterior trunk** or **metasoma**.
- (4) **Proboscis** is conical, **collar** is funnel like, while **trunk** is cylindrical.
- (5) Proboscis contains **heart vesicle**, **central sinus** and **buccal diverticulum**. It has thick muscular body wall and its cavity or coelom opens to the exterior by the proboscis pore.
- (6) **Collar** contains the **mouth** and **collar coelom** which opens by a pair of collar pores on dorsal surface.
- (7) Trunk region contains most of the internal organs, such as **pharynx**, **gonads** or **hepatic region**. **Pharynx** and **gonads** constitute **branchiogenital region**. Posteriormost part is **abdomen**.
- (8) **Branchio-genital region** is composed off : (i) **genital wing having gonad** (ii) **branchial region containing paired gills** and (iii) **hepatic region having hepatic caecae**.
- (9) Alimentation is complete and circulatory system usually contains **contractile sac of heart**.
- (10) Sexual dimorphism. **Fertilization external** and development includes **tornaria larva**. It possesses power of regeneration.

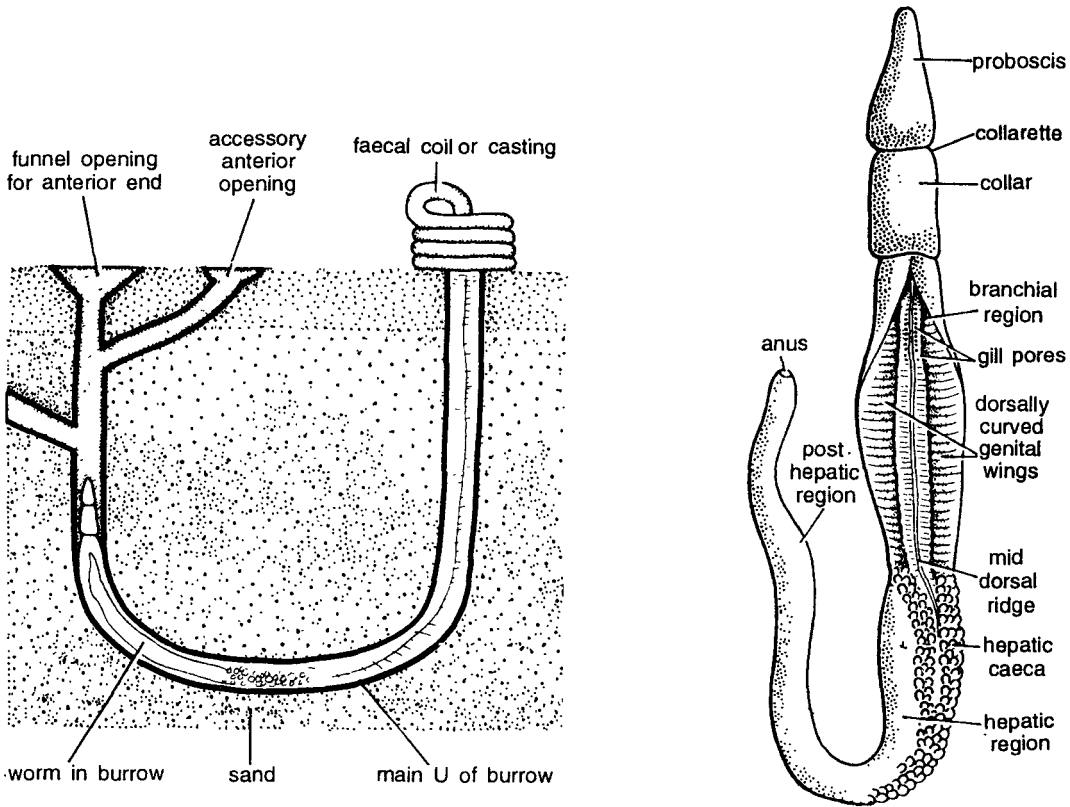

Fig. 1. *Balanoglossus*. A. Animal inside the tube, B. Entire animal.

**Special features :** *Balanoglossus* and allied forms have phylogenetic importance. Certain tissue in the form of anterior projection from the mouth cavity was formerly interpreted as a **notochord** and thus placing this group within the phylum **Chordata**. Recent studies show such structure mainly as **buccal pouch** and now the hemichordates are not included with the chordates but as separate phylum **Hemichordata**. It shows affinities with (i) Chordates (Bateson, 1885), (ii) Echinoderms (Metshinkoff, 1869), and (iii) Annelida (Spengel, 1893). Gill-slits, nerve cord and the so-called notochord are identical with chordates. Hyman (1959) objected its so-called notochord. Blastopore, ciliated bands and enterocoelous coelom are common features both in Hemichordates and Echinoderms. It resembles with Annelids also in having segmented body. It may be concluded that invertebrate features outweigh the chordate features and hence hemichordates are included in invertebrates but under separate Phylum **Hemichordata**.

**Identification :** Since the specimen contains short proboscis and all above features hence, it is *Balanoglossus*.

## 2. *Saccoglossus*

**Classification :** Same as that of *Balanoglossus*.

Genus.....*Saccoglossus*

**Geographical distribution :** It is found in New Zealand, Australia, Indopacific and Atlantic coasts and North America.

**Habit and habitat :** It is marine, burrowing and tubicolous animal. These burrow in sand flats near low tide, line, living in semipermanent tunnels lined with mucous secretions. The mouth, which apparently

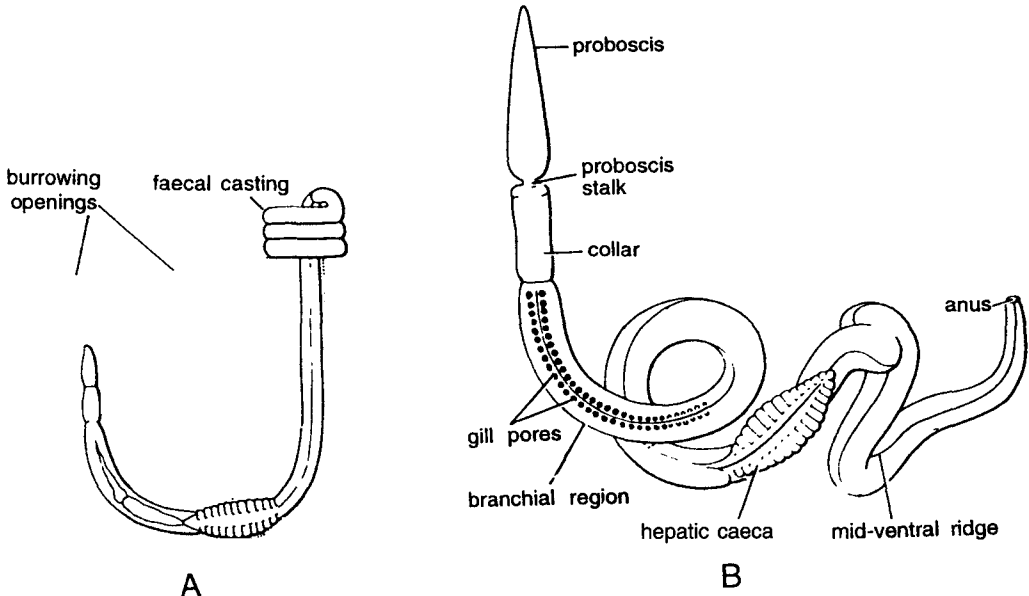

Fig. 2. *Saccoglossus*. A. Worm in its burrow, B. Entire animal out side its burrow.

cannot be closed, lies ventrally between the proboscis and collar. As the worm burrows much of the sand is swallowed.

#### Comments :

- (1) It is vermiform hemichordate.
- (2) Body regionated into proboscis (**prosoma**) collar (**mesosoma**) and trunk (**metasoma**).
- (3) **Proboscis** is exceptionally longer than any other enteropneust.
- (4) **Collar** slightly overhangs the beginning of trunk, covering three of **four gill-slits**.
- (5) **Trunk** is differentiated into three regions. In the **anterior part** numerous pairs of gill-slits open externally near the mid-dorsal line. **Middle part** has gonads which are grey in female and yellow in male. **Posterior region** has only posterior part of intestine and tapers gradually to anus.
- (6) **Hepatic sacculations** and genital ridges. So well developed in *Balanoglossus*, are absent.
- (7) Synapticulae are absent in pharynx and such tongue bars hang freely in gill-slits.
- (8) Its affinities etc., are similar to those of *Balanoglossus*.

**Identification :** Since the specimen has long proboscis and all above features, hence it is *Saccoglossus*.

### 3. *Rhabdopleura*

#### Classification :

Phylum.....	<b>Hemichordata</b>	→	Marine, enterocoelous. Notochord confined to head region.
Class.....	<b>Pterobranchia</b>	→	Small hemichordates with encased body. U-shaped intestine.
Order.....	<b>Rhabdopleurida</b>	→	Colonial, no gill-slits; 1 gonad.
Genus.....	<b><i>Rhabdopleura</i></b>		

**Geographical distribution :** It is mainly found in southern hemisphere especially resported from Norway and Ireland coasts.

**Habit and habitat :** It is a marine and colonial hemichordate, found 5 to 6 meters deep. The colony is formed on hard substratum and also in association with mollusc shells, bryozoans and tunicates.

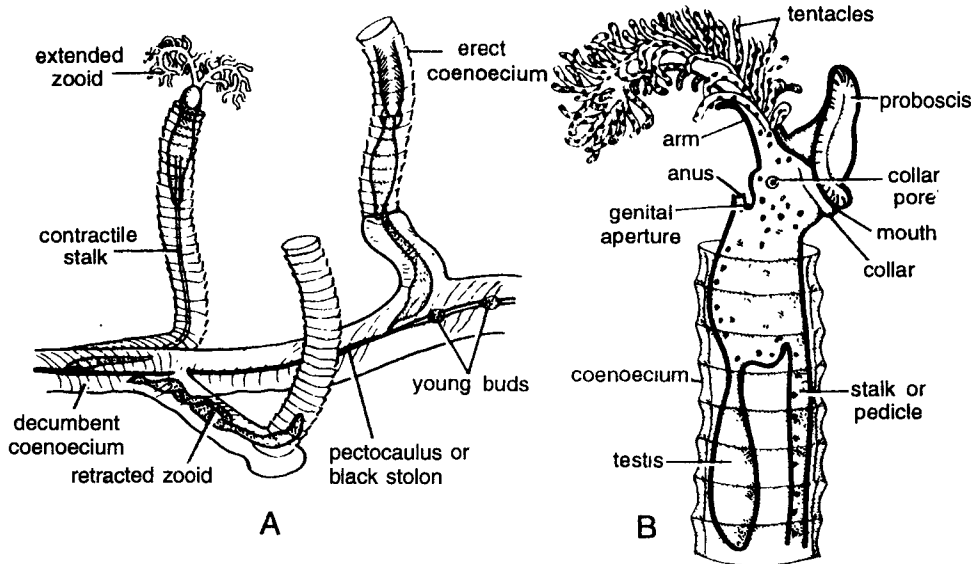

Fig. 3. *Rhabdopleura*. A. Part of Colony, B. Magnified Zooid.

#### Comments :

- (1) Colony consists of **zooids** enclosed into erect tubes which are much more elongated than zooids.
- (2) Colony contains erect coenoecium extended **zooids**, contractile stalk, decumbent **coenoecium**, retracted zooids, **pectocaulus** and young buds.
- (3) Each zooid is composed of **stalk**, **trunk sac**, **oral lamella**, **pigment stripe**, **cephalic shield**, **arms** and **tentacles**.
- (4) There is a **lophophore** with one pair of arms, one gonad, but without gill-slits.
- (5) Alimentary canal is U-shaped.
- (6) Most of the zooids are sterile, but male and female specimens may be observe.
- (7) Sexes united. Development includes a free-swimming larva.
- (8) Zooids are formed by budding, but the buds do not break off from the stolon and remain permanently attached to form a colony.

**Special features :** *Rhabdopleura* is a colonial hemichordate with organic continuity between individuals that are produced by a sexual budding from one individual.

**Identification :** Since the specimen contains extended zooids and all above features, hence it is *Rhabdopleura*.

## 4. Cephalodiscus

#### Classification :

Phylum.....	Hemichordata	→	Marine enterocoelus coelomate, Notochord confined to head region.
Class.....	Pterobranchia	→	Small hemichordates with encased body. U-shaped intestine.
Order.....	Cephalodiscida	→	Solitary or colonial, 2 gill slits, 2 gonads.
Genus.....	<i>Cephalodiscus</i>		

**Geographical distribution :** *Cephalodiscus* is found in antarctic and sub-antarctic region and restricted to archibenthal and sub-littoral zones. It has been reported from India, Japan, Sweden, Borneo, Malayasia, Archipelago and Pacific Ocean.

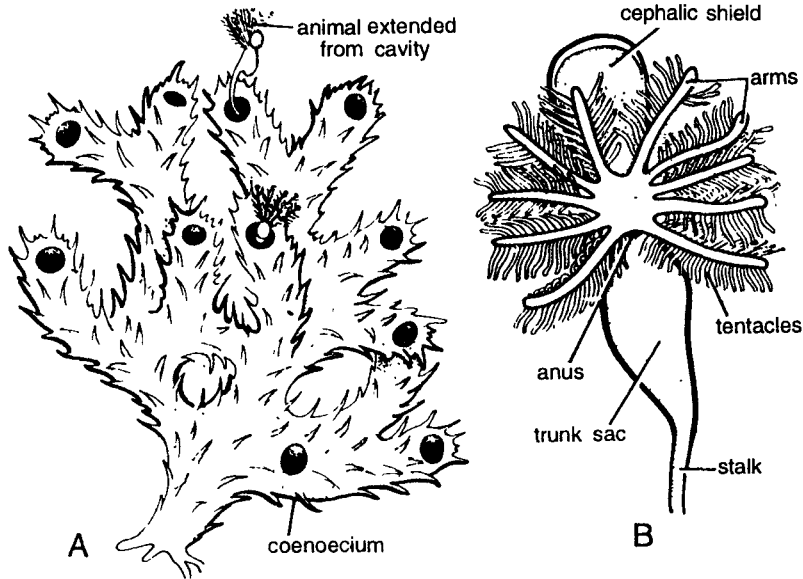

Fig. 4. *Cephalodiscus*. A. Part of Colony, B. One Zooid magnified.

**Habit and habitat :** It is a marine colonial animal, found at a depth of 50 to 60 meters. The animal was first discovered by Challenger (1876) at a depth of approximately 245 fathoms in Magellan Strait. Antarctic and Indian oceans have abundant number of this animal.

**Comments :**

- (1) Colony of *Cephalodiscus* is composed of several unconnected animals, or zooids, which are enclosed in a common case known as **coenoecium**.
- (2) Zooids have no organic connections with each other, but they can move freely in the chambers.
- (3) Zooids are microscopic and differentiated into **protosome** or **cephalic shield**, **mesosome** or **collar** and **trunk**.
- (4) **Protopharynx** or **proboscis** is flexible and contains **heart**, **buccal diverticulum** and the **central sinus**.
- (5) Protopharynx is shield-shaped and continuous with collar, which bears two groups of bilaterally arranged **arms** which contain **tentacles**.
- (6) Trunk is divided into anterior sacciform part, containing alimentation and genital organs, and posterior slender adhesive stalk. Anus is present ventrally.
- (7) Digestive tube is U-shaped.
- (8) Breeding seasonal, sexes are separate.
- (9) A sexual reproduction takes place by the budding of the stolon. New individuals detach for free existence but maintaining colonial relationship.

**Special features :** Zooids or individuals separate but aggregated into a common housing.

**Identification :** Since the specimen has coenoecium and all above features, hence it is *Cephalodiscus*.

## SUBPHYLUM II. UROCHORDATA

### Natural history

The urochordates are commonly known as **sea squirts**. Aristotle (384-322 B.C.) described a simple ascidian and called it *Tethym*. The adults do not have notochord and the body is covered with the test containing **branchial** and **atrial openings**. Tunicates inhabit sea from **polar oceans** to the **tropics**, mostly in shallow shore water, but some upto the depths of 5 km. Some are free-living, others after a short free-life attach to rocks, shells, wharf-piling or ship hulls. They vary in size from microscopic to a foot in diameter. Various coloured forms are found. They have about 2000 species, of which 100 are **pelagic**. Reproduction is sexual and asexual. The group name refers to the self-secreted 'tunic' or sac-like covering over the body. The best known tunicates are **sea squirts** or **ascidians**.

### Classification

#### Sub-phylum I. Urochordata (Tunicata)

1. Notochord and nerve cord present only in tadpole-like larva.

2. Body sac-like containing thick leathery covering or test, hence called tunicates.

#### Class 1. Ascidiacea

1. Sessile tunicates with scattered muscles in tunic.
2. Gill slits numerous.  
Ex. *Herdmania*, *Ascidia*, *Ciona*.

#### Class 2. Thaliacea

1. Chain tunicates.
2. Tunic with circular muscle bands.  
Ex. *Pyrosoma*, *Doliolum*, *Salpa*.

#### Class 3. Larvacea

1. Minute forms.
2. Tunic temporary.
3. Gill slits 2.  
Ex. *Oikopleura*.

## 5. *Ascidia*

### Classification :

Phylum.....	Chordata	→	Dorsal tubular nerve cord, gill-slits and notochord present.
Group.....	Acraniata	→	No head, cranium or brain.
Subphylum.....	Urochordata	→	Marine. Body covered by a thick test. Notochord present only in larval tail.
Class.....	Ascidiacea	→	Test with scattered muscles. Many pharyngeal gill-slits. Bottom-dwelling.
Order.....	Enterogona	→	Neural gland ventral to nerve ganglion. Gonad one.
Genus.....	<i>Ascidia</i>		

**Geographical distribution :** *Ascidia* is commonly found in cold temperate regions.

**Habit and habitat :** *Ascidia* is solitary, marine and **sedentary** urochordate inhabiting shallow water but some occur deep upto 5500 metres.

### Comments :

- (1) Commonly called as **sea squirts**.
- (2) Shape of body short and cylindrical with a broad base attached to rocky substratum.
- (3) **Test** translucent, wrinkled and brownish in colour. Below test is mantle.
- (4) Anteriorly body contains eight-lobed terminal **branchial siphon** and six-lobed sub-terminal **atrial siphon** having **mouth** and **anus**, respectively. Mouth is surrounded by 50-100 **tentacles**.
- (5) Branchial siphon leads into **pharynx** which is perforated by **stigmata**. Pharynx contains **endostyle**.
- (6) **Dorsal tubercle** separated from the **nerve ganglion** neural gland and membranous **dorsal lamina**.
- (7) Alimentary canal consists of mouth **pharynx**, **stomach**, **intestine**, **rectum** and **anus**.
- (8) **Gonads**, **gonoduct** and gonopore distinct.
- (9) Monoecious. Ovary, testes in the same animal. Reproduction sexual. Oviparous. Metamorphosis **retrogressive**.

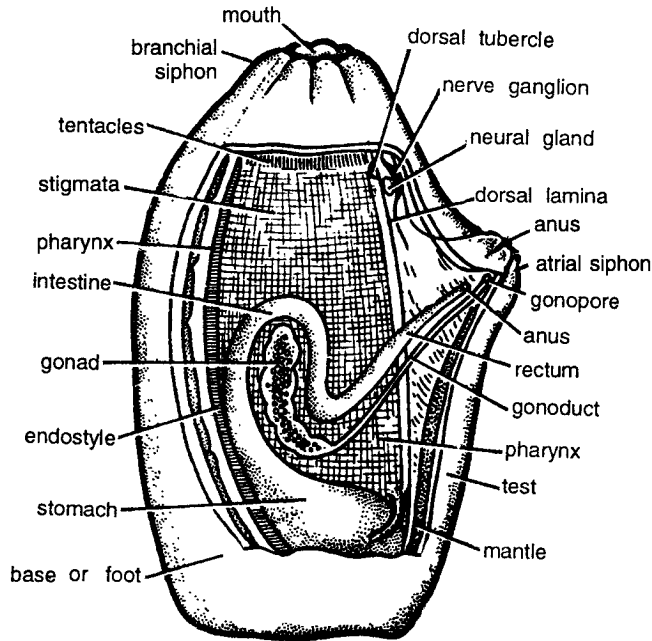

Fig. 5. *Ascidia* : Partly dissected to show anatomy.

**Special features :** There are some **compound ascidians** in which individuals are buried in a common test. The development includes tailed larva exhibiting typical chordate characters having notochord, nerve cord, etc. Kowalewsky (1886) carefully studied the development of larval ascidians and brilliantly demonstrated true position of the group among chordates. The tunicates are best understood by studying first free-living larva of an ascidian, than the adult. The larva shows chordate characters but some are absent in adult and others are modified to sessile mode of life. Compound ascidians reproduce asexually by **gemmation** and also produce eggs and sperms for sexual reproduction.

**Identification :** Since the animal contains lobed siphons and all above features, hence it is *Ascidia*.

## 6. *Ciona*

**Classification :** Same as in *Ascidia*.

Genus..... *Ciona*

**Geographical distribution :** *Ciona* is a common mono-ascidian found in shallow waters.

**Habit and habitat :** **Solitary** and **sedentary** animal found in shallow waters attached with rocks.

**Comments :**

- (1) *Ciona* resembles with *Herdmania* and measures 9 to 12 cm in length.
- (2) Body of the animal cylindrical, tubular, transparent and longer than broad.
- (3) It contains 8-lobed **branchial siphon** and 6-lobed **atrial siphon** anteriorly.
- (4) Branchial and atrial siphons contain mouth and atriopore respectively. Tentacles present at the base of branchial siphon. One left side **nerve ganglia** present.

- (5) Body covered by a **transparent test** and through the **test**, prominent thick **longitudinal muscle bands** can be seen. Below test is **mantle**.
- (6) Alimentary canal is complete, U-shaped and consists of **pharynx, oesophagus, stomach** and **intestine** and it lies in the epicardial cavity. **Heart** is surrounded by **pericardium**.
- (7) Different parts of gut occupy the same topographical parts as that in *Herdmania*. The gill-slits are rectangular. The **dorsal lamina** present. **Intestine** contains **typhlosole**. Running parallel with the **endostyle** are right and left ciliated bands which continue posteriorly as **retropharyngeal bands**.
- (8) **Gonads** lie in the loop of intestine. **Gonads** open by **genital pore** through the **genital duct**.
- (9) Longitudinal muscle bands are clearly seen.
- (10) Fertilization external and the floating egg develops into an *Oikopleura*-like larva which settles and undergoes metamorphosis to change into adult.

**Special features :** *Ciona* is **hermaphroditic** and **protogynous**. The blood of *Ciona* is rich in a green pigment, called as **haemovanadin**, containing **vanadium** produced by **vanadocytes**. The pigment probably does not take part in oxygen transport. *Ciona intestinalis* is the common species.

**Identification :** Since the animal contains thick longitudinal muscle bands and above features hence, it is *Ciona*.

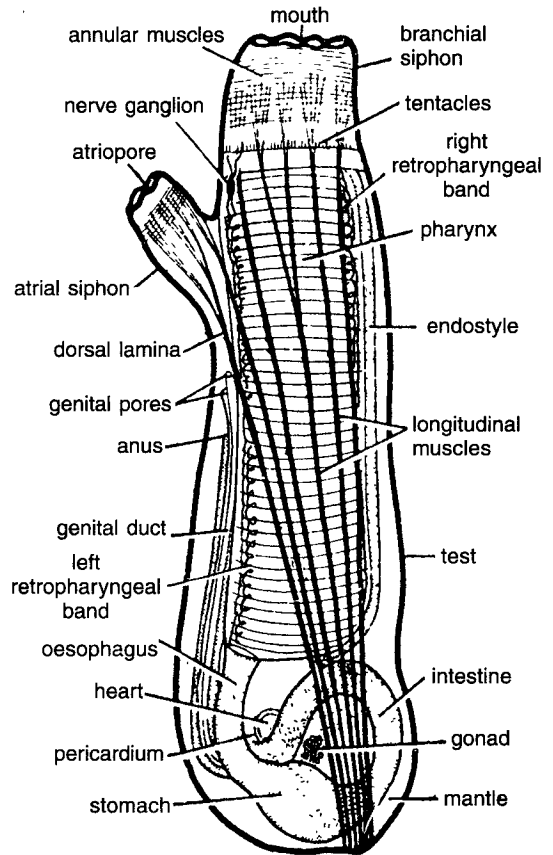

Fig. 6. *Ciona*.

## 7. *Herdmania*

**Classification :** Same as in *Ascidia*.

Genus..... *Herdmania*

**Geographical distribution :** Different species of *Herdmania* (= *Rhabdocynthia*) are widely distributed in the Pacific, Atlantic and Caribbean seas, besides Indian Ocean.

**Habit and Habitat :** **Solitary, sedentary** and sometimes living as commensal in association with gastropod shells, specially over *Xancus pyrums* (Shankh) and *Xancus angulatus* (Conch).

**Comments :**

- (1) It is commonly called as Monoacidian or **Sea squirt**. Das S.M. (1936) wrote a memoir on this animal.
- (2) It is more or less like a purse or large oval potato, measuring 6.5 to 11.8 cm in length and 5.2 to 6.9 cm in breadth.
- (3) Body **dark brown**, reddish brown or yellowish **brown** in colour and regionated into soft **body proper** and **foot**.
- (4) Foot large, dirty, rough, leathery and with a number of foreign objects. It forms one-third of the body.
- (5) Body enclosed in a thick, tough and supporting **transparent test** or **tunic** in the form of a thick translucent protective investment meant for respiration and reception of stimuli. It is composed of polysaccharide, called as **tunicin**, and protein.



- (6) Without cutting the animal open at the free end, body is drawn to form 1.0 cm long **branchial** or **incurrent siphon** and 1.5 cm long **atrial** or **excurrent siphon**. The incurrent opening of **mouth** is somewhat laterally placed, while the excurrent opening is directed upwards. Branchial and atrial apertures are found on branchial and atrial siphons respectively.
- (7) Body proper lies within **test**.
- (8) *Herdmania* is **hermaphroditic** and **protogynous**.
- (9) Fertilization external. Development includes a fully formed larva, called **ascidian tadpole** larva. It contains all the chordate characters *i.e.*, notochord and nerve chord, etc.
- (10) Metamorphosis is **retrogressive** in which notochord, nerve cord, tail and tail fins are degenerated. By the time adult is formed, all chordate characters disappear.

**Special features :** *Herdmania* in adult form is devoid of any chordate characters which are exhibited only by its tadpole larva. Animal has also a peculiar symmetry; branchial aperture marks the **anterior end** and opposite end is the **posterior end**. The atrial aperture indicates **dorsal side** and the area diagonally opposed to it represents **ventral side**. Such abnormal symmetry is brought about by metamorphosing larva into sedentary adult.

**Identification :** Since the animal contains soft translucent body and atrial and branchial apertures, at the same level and all above features, hence it is *Herdmania*.

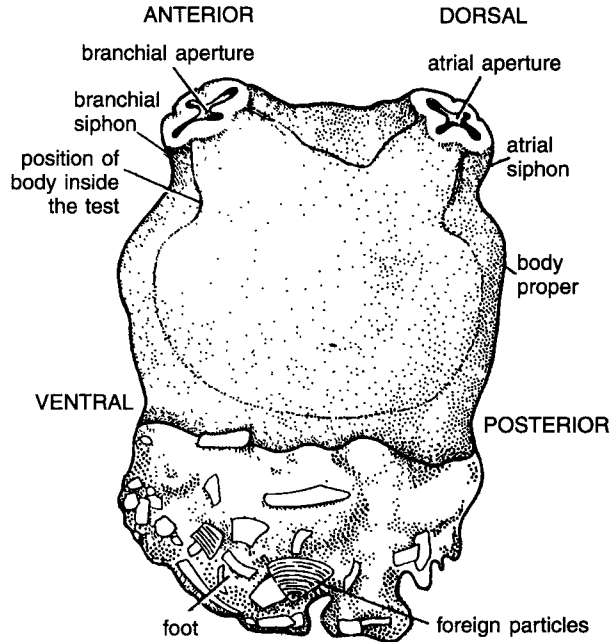

Fig. 7. *Herdmania*.

## 8. *Pyrosoma*

### Classification :

Phylum.....	Chordata	→	Dorsal tubular nerve cord, gill-slits and notochord present.
Group.....	Acraniata	→	No head, cranium or brain.
Subphylum.....	Urochordata	→	Marine. Body covered by a thick test. Notochord present only in larval tail.
Class.....	Thaliacea	→	Test with circular muscle bands. Free-living, pelagic.
Order.....	Pyrosomida	→	Compact tubular colony. No larva. Muscle bands at end of body.
Genus.....	<i>Pyrosoma</i>		

**Geographical distribution :** *Pyrosoma* is distributed in tropical and sub-tropical regions.

**Habit and habitat :** *Pyrosoma* is **pelagic, marine, colonial** and **bioluminescent** urochordate, found at a depth of 500 meters. A few forms are **abyssal**.

### Comments :

- (1) It is a thimble-shaped **hypopleustonic** colony, 25 cm to 1 metre in length and consists of several **individuals**, called **blastozooids**, embedded in a common test having test processes and terminal opening.

- (2) Colony floats horizontally and is like a balloon cylinder. **Zooids** are arranged in the wall of the cylinder.
- (3) Branchial and atrial apertures are at opposite ends. Branchial openings or **mouths** of individuals or zooids open to the outside, while atria open into a common **cloaca** with a terminal outlet, from which a continuous jet emerges.
- (4) Colony moves by a jet propulsion. Rhythmic contractions of muscular bands in the body wall cause ejection of water through **pharynx** and **atrium** with sufficient force to propel the organism.
- (5) Each zooid consists of a large branchial sac with **endostyle** and **dorsal lamina**, **neural complex**, **heart** and **atrium**.
- (6) Branchial sac contains 50 gill-slits divided by internal longitudinal bars. **Endostyle** communicates with peripharyngeal band, retropharyngeal band and dorsal lamina. Intestine makes a loop around stomach and ends into atrium. **Heart** is ventral. Lobed testis is found behind ovary.
- (7) Close to the mouth of each zooid arises a tongue-like process of the test, called as **buccal appendage**. Other structures seen are **testes**, **anus**, **stomach**, oesophagus **intestine**, **atrial muscles**, **stigmata**, **mass** of mesodermal cells, dorsal tubercle, muscle fibers, **luminous organs** and **tentacles**.
- (8) **Hermaphroditic**. Reproduction sexual and asexual.
- (9) A single fertilized egg develops within blastozoid and gives rise to asexual oozoid. It gives stolon that forms 4 ascidiozooids or tetrazoid which degenerates and gives rise to cyathozoid. It is enclosed in a test and by repeated budding forms a colony.
- (10) Asexually colony multiplies the number of zooids by direct stolon **budding**, producing blastozoids.

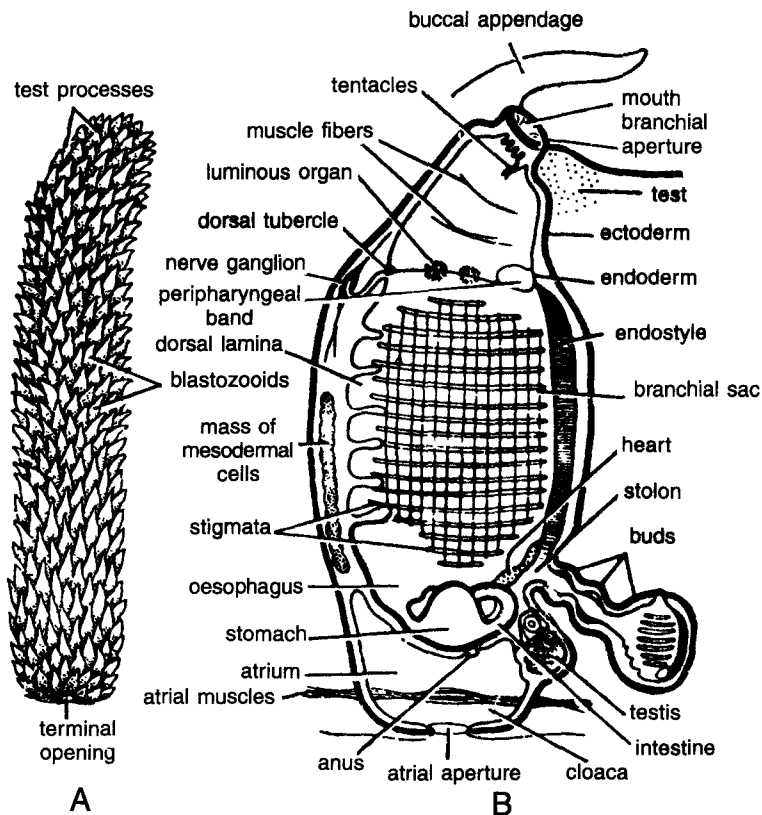

Fig. 8. *Pyrosoma*. A. Colony, B. Single zooid.

**Special features :** The most **outstanding** characteristic of the creature is the shining of powerful light without heat, a phenomenon called as **bioluminescence**. Animal produces **light** on stimulation and when all colonies produce light, the entire area is illuminated as much as one can read the book. Light is produced by **bioluminescent cells**, which contain curved inclusions. According to some, these bioluminescent cells contain luminescent symbiotic bacteria. However, in any case, **light** is emitted by the **chemical interaction** between two compounds, **luciferin** and **luciferase**, in the presence of moisture.

**Identification :** Since the animal contains opposite branchial and atrial siphons with thimble-shaped colony and above features, hence it is *Pyrosoma*.

## 9. *Doliolum*

### Classification :

<b>Phylum</b> .....	<b>Chordata</b>	→	Dorsal tubular nerve cord, gill-slits and notochord present.
<b>Group</b> .....	<b>Acraniata</b>	→	No head, cranium or brain.
<b>Subphylum</b> .....	<b>Urochordata</b>	→	Marine. Body covered by a thick test. Notochord present in larval tail.
<b>Class</b> .....	<b>Thaliacea</b>	→	Test with circular muscle bands. Free-living, pelagic.
<b>Order</b> .....	<b>Doliolida</b>	→	Complete ring of muscle bands or cyclomyaria present.
<b>Genus</b> .....	<b><i>Doliolum</i></b>		

**Geographical distribution :** *Doliolum* is distributed in tropical and sub-tropical surface water.

**Habit and habitat :** *Doliolum* is a **marine, pelagic, free-living and solitary** tunicate swimming by forcing water out of atrium after each powerful muscle contraction.

### Comments :

- (1) *Doliolum* is commonly called as **chain tunicate**. It measures 1 to 1.5 cm.
- (2) It shows **polymorphism** and exists in two phases : (i) **gonozooid** or solitary phase, and (ii) **oozooid** or gregaria phase.
- (3) Fully grown **oozooid** has a barrel-shaped transparent body, a large **mouth, branchial** and **atrial apertures** at opposite ends and 8 complete muscle bands. Body covered by test and below test is mantle : (i) Edges of above lobes contain sensory lobes, 10 on branchial and 12 on atrial side,

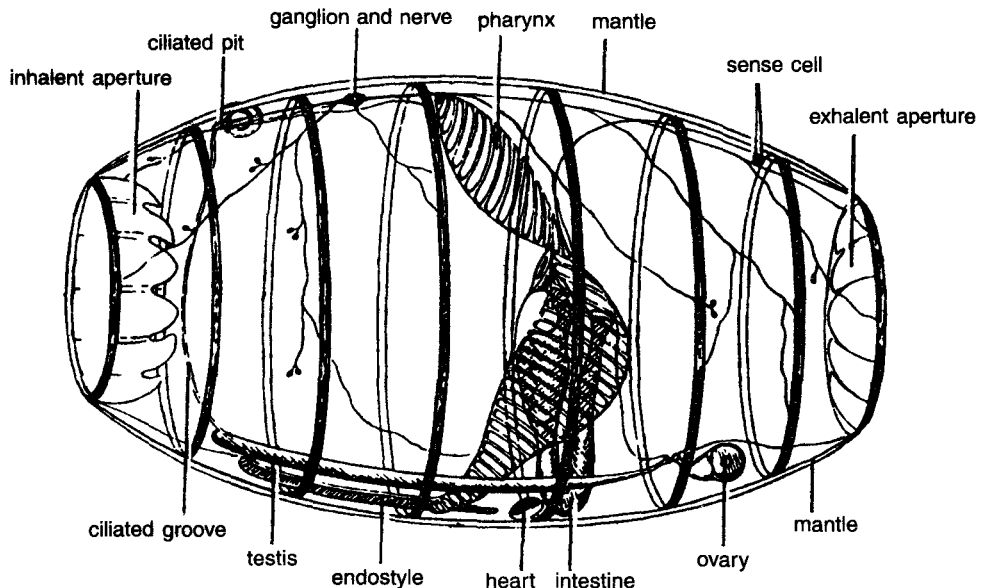

Fig. 9. *Doliolum*. Oozooid.

- (ii) **Mouth** leads into **pharynx** with a few **stigmata**. It has ventral **endostyle**, and **peripharyngeal bands**. Viscera consists of **oesophagus, stomach, intestine, digestive gland, heart** and **neural complex**,  
 (iii) Oozoids reproduce asexually by **stolon budding**.
- (4) Life-cycle is peculiar consisting of 1. **Sexual** form 2. Tailed larva developed sexually 3. First asexual form 4. Second asexual forms (**Phoro zooid**) developed on cadophore and buds developed on stolon.
- (5) The animal moves through water by jet propulsion. The contraction of the muscle bands drives water backwards out of atrial sac and so propels the animal.
- (6) Gonozooid can be differentiated from oozoid in having 12 and 10 sensory lobes in branchial and atrial openings, 8 muscle bands, cadophore and otocyst absent and with testis and ovary.

**Special features :** *Doliolum* is a favourite tunicate. The fertilized egg develops into a free-swimming tailed larva somewhat like that of an ascidian. The larva metamorphoses into a barrel-shaped adult '**nurse**' stage that by asexual reproduction gives rise to several individuals. Some even produce sperm and ova.

**Identification :** Since the animal contains 8 complete circular muscle bands and above features, hence it is *Doliolum*.

## 10. *Salpa*

### Classification :

<b>Phylum</b> .....	<b>Chordata</b>	→	Dorsal tubular nerve cord, gill-slits and notochord present.
<b>Group</b> .....	<b>Acraniata</b>	→	No head, cranium or brain.
<b>Subphylum</b> .....	<b>Urochordata</b>	→	Marine. Body covered by a thick test. Notochord present in larval tail.
<b>Class</b> .....	<b>Thaliacea</b>	→	Test with circular muscle bands. Free-living, pelagic.
<b>Order</b> .....	<b>Salpida</b>	→	Incomplete muscle bands. No larva.
<b>Genus</b> .....	<b><i>Salpa</i></b>		

**Geographical distribution :** *Salpa* is commonly found in tropical waters.

**Habit and habitat :** Salpians are highly modified and peculiar tunicates, living in open sea with specialized reproduction. They are found on surface and down to depths of 200 meters.

### Comments :

- (1) Body of the animal is cask-shaped, measuring 1 to 8 cm in length and covered by a thick test. The **branchial** and **atrial apertures** are at opposite ends. Posteriorly the test is produced into two tail processes. Below test is mantle.
- (2) *Salpa* exhibits **polymorphism** and exists in two phases : (i) **oozooid** or asexual phase, and (ii) **blastozooid** or sexual phase or aggregate type. Two phases are very much alike, but oozoids are smaller in size and having lesser number of muscle bands. Sexually produced *Salpa* is called as **solitary type** or oozoid, while alternate generation produced by budding is called as **aggregate type** or blastozooid.
- (3) Typical oozoid consists of branchial and atrial apertures at opposite ends. A ciliated funnel is present on dorsal side. **Nerve ganglion, dorsal lamina** and **pharynx** which has **endostyle, peripharyngeal band** gill present.
- (4) Oesophagus, stomach, intestine and gonad constitute a compact mass along the postero-ventral side which is called as **visceral nucleus. Muscle bands incomplete.**
- (5) A **stolon** originates from ventral side and it carries endostylic and mesenchymal extensions. **Stolon** produces **buds** or **blastozooids**.
- (6) Blastozooid is a sexual phase, having paired testes and a single ovary.
- (7) Blastozooid is **protogynous**. Fertilization is internal. Ovum gives rise to a single sexless free oozoid.
- (8) Important character of the animal is **locomotion** by propelling mechanism in which active muscle bands contract and intumed water is ejected through atrial pore.

**Special features :** Sexual and asexual generations alternate a single adult asexually produces several hundred individuals connected to one another. Small fragments of such a chain consisting of several

animals, sometimes break loose from parent. Both connected and separated individuals reproduce sexually. Each individual produces one or several eggs that remain connected to parent by a placenta-like structure, analogous to that of higher chordates where the maternal and embryonic circulation are closely related during development. The hatching egg becomes **asexual** form.

**Identification** : Since the animal contains chain of buds, test processes, incomplete muscle bands and above features, hence it is *Salpa*.

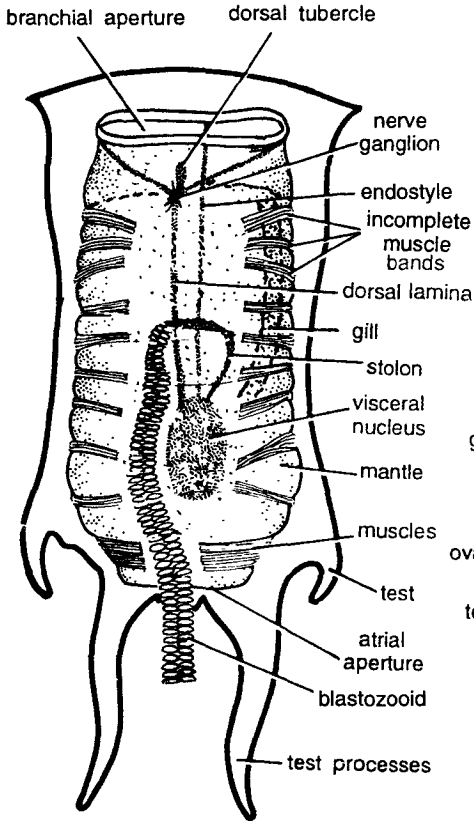

Fig. 10. *Salpa*.

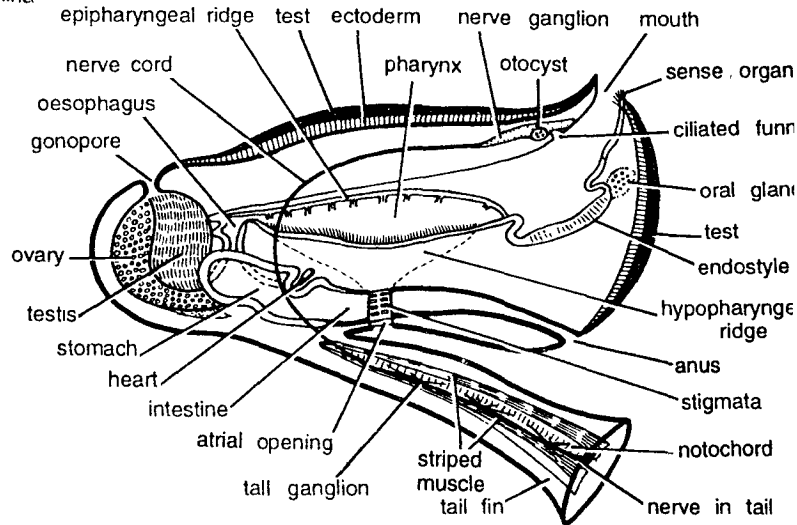

Fig. 11. *Oikopleura*.

## 11. *Oikopleura*

### Classification :

Phylum.....	Chordata	→	Dorsal tubular cord, gill-slits and notochord present.
Group.....	Acraniata	→	No head, cranium or brain.
Subphylum.....	Urochordata	→	Marine. Body covered by a thick test. Notochord present in larval tail.
Class.....	Larvacea	→	Minute. Tunic temporary. 2 gill-slits.
Genus.....	<i>Oikopleura</i>		

**Geographical distribution** : *Oikopleura* is widely distributed in open sea.

**Habit and habitat** : *Oikopleura* lives in upper levels of the sea and swims by contractions of the bent tail. Some are **brilliantly pigmented** (coloured) with orange or violet and when abundant, may colour the water. It is a **neotenus** and **planktonic** tunicate.

**Comments :**

- (1) *Oikopleura* is minute and microscopic measuring about 2 mm.
- (2) Animal lives in a 'house or test' made by secretion from a special part of the skin, called as **oikoplastic epithelium**. Body wall contains test and **ectoderm**.
- (3) It has larva-like appearance comprising body, tail and persistent **notochord**.
- (4) Body narrows towards mouth and expands posteriorly dorsoventrally. The caudal appendages have undergone torsion of 90°.
- (5) Tail is a broad structure, which rests at an angle to the rest of the body. It has **notochord, nerve cord, broad tail fin** and 7 to 12 **striped muscle cells**.
- (6) Movement of the tail produces water current. Food particles are filtered by an elaborate arrangement in the house. Water enters into house by a pair of posterior filtering windows and is passed through filter pipes in front of mouth. Minute flagellates are sucked by mouth.
- (7) Dorsal lamina and tentacles are absent. Otocyst present.
- (8) Mouth leads into alimentation comprising of **pharynx, oesophagus, stomach** and **intestine**. Pharynx has gill-slits opening to outside. The food consists of microorganisms. Sense organs, oral gland, otocyst, tail ganglous, atrial opening muscle bonds epipharyngeal ridge, otocyst, epipharyngeal ridge.
- (9) **Protandrously hermaphroditic**, kidney-shaped two testis. Left testis encloses, ovary.
- (10) Internal space filled by haemocoelomic lacunae having blood circulation by a transport heart.

**Special features :** The general structural organization resembles with a typical ascidian tadpole and it can be very safely concluded that these forms have arisen from tunicates by the acceleration of the rate of development of alimentation and reproductive systems, so that the metamorphosis and the adult stage are omitted and it shows phenomenon of **neoteny** or **paedomorphosis**. The anatomy of the animal suggests that larvaceans are not like the ancestral chordates but are neotenic descendants of the sessile ancestors resembling Urochordata.

**Identification :** Since the animal contains peculiar body with persistent tail having notochord, etc. and above features, hence it is *Oikopleura*.

## SUBPHYLUM III. CEPHALOCHORDATA

**Natural history**

*Amphioxus*, a small superficially fish-shaped chordate, constitutes subphylum Cephalochordata of the phylum Chordata. It is the first chordate adult, of course, very peculiar. Costa (1834) coined the name *Branchiostoma*. Yarrell (1836) christened it as *Amphioxus*. Although the name *Branchiostoma* has priority over *Amphioxus* but inadequacy of Costa's description creates doubts regarding validity of the name *Branchiostoma*. However, the name *Amphioxus* is more famous and familiar to zoologists. There is a single class, *Leptocardii*, in the subphylum.

**Classification**

1. Notochord and nerve cord along entire body and persistent.
2. Pharynx with numerous gill slits.

**Class Leptocardii**

1. Segmented, slender, fish-like lancelets.
2. Epidermis single-layered, without scales.
3. Gill slits many.

Ex. *Amphioxus* (= *Branchiostoma*)

## 12. *Amphioxus lanceolatus* or *Branchiostoma lanceolatum*

### Classification :

Phylum.....	Chordata	→	Dorsal tubular nerve cord, gill-slits and notochord present.
Group.....	Acraniata	→	No head, cranium or brain.
Subphylum.....	Cephalochordata	→	Notochord along entire body length and persistent.
Class.....	Leptocardii	→	Numerous pharyngeal gill-slits.
Genus.....	<i>Amphioxus</i> (= <i>Branchiostoma</i> )		
Species.....	<i>lanceolatus</i>		

**Geographical distribution :** Widely distributed in temperate and tropical seacoasts.

**Habit and habitat :** *Amphioxus burrows* in clean shifting and shallow shore waters leaving only its anterior end protruded. For most of the times, it remains buried in the sand but in darkness it swims very rapidly by lashing movements of the tail. It is a **ciliary feeder**.

### Comments :

- (1) Commonly called as **lancelet**.
- (2) It was first discovered by Pallas (1778).
- (3) Adult is less than 5 cm long and has superficially fish-like structural make up.
- (4) Body is elongated, flattened, non-pigmented and pointed at both ends as the name implies. Anterior end projects forwards as the **rostrum**.
- (5) **Dorsal, ventral and caudal fins** are low and continuous. There are 2 lateral fins or **metapleural folds**. Dorsal fin has fin rays.
- (6) Ventral **mouth** is guarded by **oral hood** containing **oral cirri**.
- (7) **Atriopore** is median and ventral. Anus on left side.
- (8) **Myotomes** are arranged on both sides of die body as metamerial blocks of striated muscle fibres separated by V-shaped partitions called as **myosepta** or **myocommata**.
- (9) Notochord is an axial skeletal rod extending from anterior to posterior end. Nerve cord lies just above the notochord.
- (10) Gonads 26 pairs, metamerially arranged on pharynx. The two sexes are separate but without **sexual dimorphism**.

**Special features :** Although eyes, nose, ears, jaws and appendages are completely absent, yet *Amphioxus* is of **special zoological interest**, because it shows three distinctive characters of the phylum Chordata in simple form *i.e.*, presence of **notochord, nerve cord and gill-slits**. It is considered to resemble some ancient ancestor of the phylum Chordata. Further *Amphioxus* shows combination of primitive, specialized and degenerate features. Primitive features include notochord extending into snout, segmented myotomes, straight intestine, absence of jaws and paired fins, ciliary feeding and no specialized heart. The specialized features comprise of elaborate velum and oral hood and several gill-slits. The reduced brain and sense organs are degenerate features.

**Identification :** Since the animal contains oral hood, spindle-shaped body and myotomes and above features, hence it is *Amphioxus*.

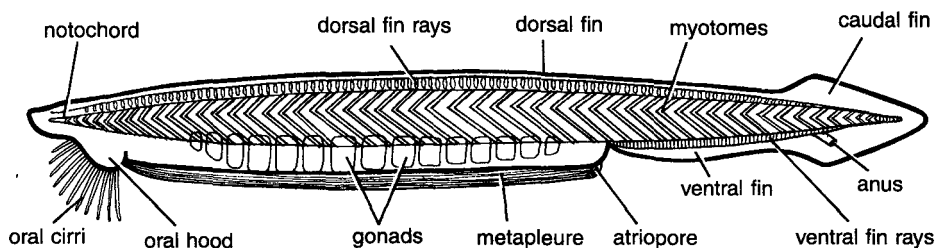

**Fig. 12.** *Amphioxus*.

## SUPERPHYLUM IV. VERTEBRATA CLASS CYCLOSTOMATA

- (1) Skin without scales. Mouth suctorial.
- (2) Gills 5 to 16 pairs.
- (3) Skeleton cartilaginous.

**Order 1. Petromyzontia.** It includes **lampreys** which attach to the body of fishes.

Ex. *Petromyzon* = *Lampetra*, *Huviatilis*.

**Order 2. Myxinoidea.** It includes **hagfishes**. These bore into the bodies of fishes and live inside until the carcass loses the entire flesh.

Ex. *Myxine*, *Bdellostoma*.

### 13. *Petromyzon*

#### Classification :

Phylum.....	Chordata	→	Dorsal tubular nerve cord, gill-slits and notochord present.
Group.....	Craniata	→	Definite head. Cranium with simple brain present.
Subphylum.....	Vertebrata	→	Vertebral column present.
Division.....	Agnatha	→	Jaws and paired appendages absent.
Class.....	Cyclostomata	→	Mouth circular, suctorial, without jaws.
Order.....	Petromyzontia	→	Mouth with funnel, without tentacles. Nasopharyngeal pouch blind. Gills 7 pairs, open independently to exterior. Branchial basket well developed.

Genus..... *Petromyzn*

Species..... *marinus*

**Geographical distribution :** *Petromyzon marinus* is found in world-wide sea waters, coastal regions, streams and lakes of North America, Europe, West Africa, Australia, Chile, Japan, New Zealand, Tasmania.

**Habit and habitat :** *Petromyzon* is found both in salt and fresh-water. They lead an **ectoparasitic** life on other fishes, attaching to the body of host by buccal funnel and secreting an anticoagulant for continuous flow of blood. They are also **anadromous** i.e., ascending river for spawning. **Carnivorous** and **predators**.

#### Comments :

- (1) Commonly called as **lamprey** [Fig. 13 (a), (b)].

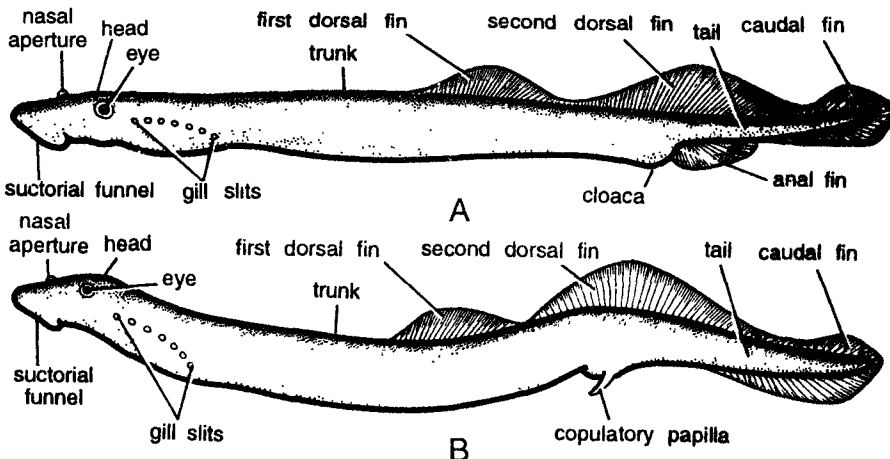

Fig. 13. *Petromyzon*. A. Female, B. Male.



- (2) Body is **eel-like**, measuring about 90 cm, and differentiated into **head, trunk and tail**. First dorsal fin, second dorsal fin and caudal fin confluent.
- (3) Skin is without **scales**, slimy, **green, brown** and with strong metallic lustre.
- (4) **Head** contains mouth but **no jaws**. **Mouth** is surrounded by a large, ventral, **suctorial funnel** with numerous horny teeth. The '**tongue**' is toothed and piston-like.
- (5) **Dorsal nasal sac** and mouth are unconnected. Paired eyes are present behind **nasal-aperture**.
- (6) **Gill-slits** are 7 pairs and **branchial basket** is well developed.
- (7) **Sexes** are separate. Female with large **anal fin**. Male with urinogenital or **copulatory papilla**. The development includes **ammocoete** larva which is very important phylogenetically as it is regarded a connecting link between *Amphioxus* and cyclostomes.

**Economic importance :** (i) Lampreys have very little food value, (ii) They injure and destroy fishes by sucking blood and causing secondary infection, (iii) Larval lampreys are used as bait for sport fishing and commercial fishing.

**Special features :** Lampreys are the lowest **jawless vertebrates** and their nearest allies are the ancient **ostracoderms** of Silurian and Devonian periods. There are no fossil representatives of this group to indicate their course of evolution.

**Identification :** Since the animal has 7 pairs of gill pores and is without jaws and has above features, hence it is *Petromyzon*.

## 14. Myxine

### Classification :

Phylum.....	Chordata	→	Dorsal tubular nerve cord, gill-slits and notochord present.
Group.....	Craniata	→	Definite head. Cranium with brain present.
Subphylum.....	Vertebrate	→	Vertebral column present.
Division.....	Agnatha	→	Jaws and paired appendages absent.
Class.....	Cyclostomata	→	Mouth circular, suctorial, without jaws.
Order.....	Myxinoidea	→	Mouth without funnel, with 8 tentacles. Gills 10 to 14 pairs. Branchial basket feebly developed.

Genus..... *Myxine*

**Geographical distribution :** *Myxine* is distributed along seacoasts of the Atlantic and Pacific oceans in North European, North Atlantic, American and Japanese sea waters.

**Habit and habitat :** Hagfishes or *Myxine* sometimes descend to a depth of 300 fathoms. They are purely marine, **nocturnal** and lie buried in the muddy bottom. They are **parasitic** or **quasiparasitic** and generally found attached to the body of fishes, especially around gill area. They bore their way into host body to eat viscera and muscles.

### Comments :

- (1) Commonly called as **hagfish** or **borer**.
- (2) Body is **soft**, without scales, worm-like, measuring about 60 cm in length and differentiated into **head, trunk and tail**.
- (3) Anterior extremity contains four tentacles supported by skeletal rods.

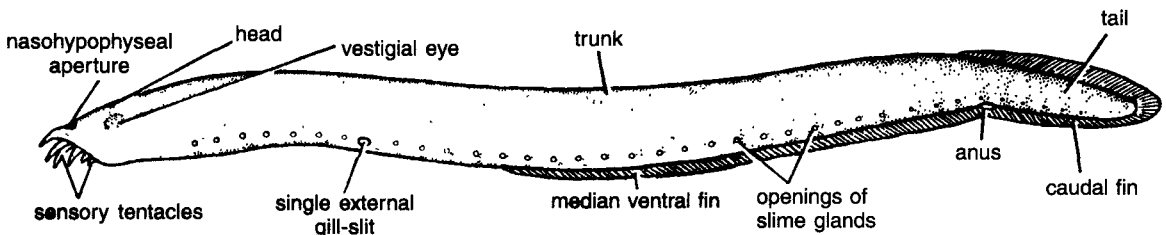

**Fig. 14.** *Myxine*.

- (4) Mouth is terminal and surrounded by lips. **Buccal funnel**, and **jaws** are absent.
- (5) There is a single nostril present close to the mouth. On ventrolateral sides mucous pores and distinct.
- (6) Dorsal fin indistinct **caudal fin** and ventral fin confluent.
- (7) **Eyes vestigial**, due to dark and bottom dwelling habit, photoreceptor organ is reduced.
- (8) Secrete enormous mucus through mucous pores.
- (9) 10 to 14 pairs of gills open into a **branchial chamber**, which opens to the exterior by a single branchial opening.
- (10) **Hermaphroditic** and **protandrous**. Eggs are enclosed in horny shell, bearing hooks by which they attach themselves to the weeds.

**Economic importance :** Hagfishes damage fish caught in nets. Sometimes hagfishes enter into the body of other fishes and eat entire soft parts leaving only a bag of skin and the bones.

**Special features :** In hagfishes same individual produces sperms and then eggs later on. Development is direct. The hagfishes are **injurious to fish industry**. They are important from evolutionary point of view. The evolution of jawed vertebrates from agnathans could be hypothesized as the latter needed only jaws. Although no direct link is available to understand evolution of gnathostomes, but some armoured agnathan might have served as ancestor to the jawed vertebrates.

**Identification :** Since the animal has 4 tentacles, single gill aperture and no buccal funnel and above features, hence it is *Myxine*.

## 15. *Bdellostoma*

**Classification :** Same as in *Myxine*.

Genus.....*Bdellostoma*

**Geographical distribution :** *Bdellostoma* is distributed in the Pacific coasts of North and South America, South Africa and New Zealand.

**Habit and habitat :** *Bdellostoma* is found buried in mud and sand during day; otherwise it is **nocturnal feeder and ectoparasitic** and highly adapted for sucking.

**Comments :**

- (1) *Bdellostoma* is also commonly called as **hagfish**.
- (2) Body elongated, soft, eel-like without scales and divided into **head, trunk and tail**.
- (3) Teeth are well developed. **Jaws** are completely absent.
- (4) Eyes are rudimentary, skin sensory. Eight sensory tentacles are found around mouth. Single nostril is very close to the mouth.
- (5) Gills are modified into **pouches** which are 6 to 14 in number and they open independently.
- (6) Entire body contains double rows of mucous glands. On ventro-lateral side is row of mucous pores.
- (7) Blood is isosomatic with sea water. **Dorsal fin continuous with caudal fin**.
- (8) Egg is yolky with partial cleavage leading to the formation of an embryo perched on a mass of yolk.
- (9) Single pineal eye is present at the top of head.
- (10) Nostril is **hermaphroditic** and **protandrous**.

**Special features :** It has the same **phylogenetic importance** as that of *Myxine*. **Pronephros** persistent in the adult but the functional kidney is **mesonephros**.

**Identification :** Since the animal is without jaws and with 8 tentacles and above features, hence it is *Bdellostoma*.

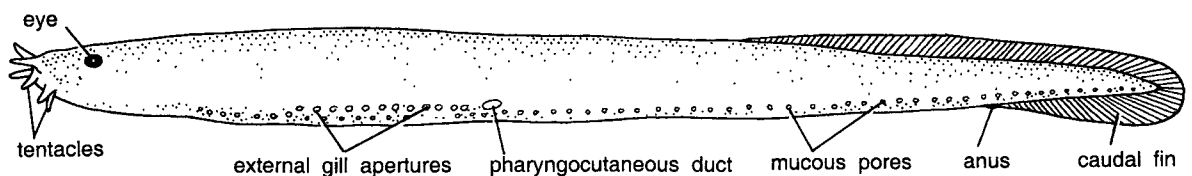

Fig. 15. *Bdellostoma*.

## SUPER CLASS PISCES (= FISHES)

### Expanded Classification

#### Superclass Pisces

1. Paired fins and gills present.
2. Skin with dermal scales.

#### CLASS 1. PLACODERMI

1. Primitive jawed fishes with transverse articulation between skull and shoulder girdle.
2. Full-sized functional gill arch preceded by hyoid arch.  
Ex. Extinct jawed fishes such as *Climatius*, *Acanthodes*, *Coccosteus*, *Pterichthyodes*.

#### CLASS 2. CHONDRICHTHYES

(= Elasmobranchi)

1. Cartilaginous fishes (Skeleton of cartilage).
2. Scales placoid. 1st gill slit a spiracle.
3. Mouth and 2 nostrils ventral.
4. Males with claspers.
5. Ova few, large, with much yolk. Cleavage meroblastic.

##### Sub-class A. Selachii

1. Sharks. Spiracle behind each eye.
2. Multiple gill slits on either side protected by individual skin flaps.

##### Order 1. Squaliformes or Pleuretremata

1. Body typically spindle-shaped.
2. 5 to 7 pairs of lateral gill slits.
3. 2 dorsal and 1 caudal fin. Pectoral fins moderate.  
Ex. Sharks. *Scoliodon*, *Mustelus*, *Sphyrna*, *Stegostoma*, *Scyllium*, *Rhineodon*, *Sauatina* and *Chiloscyllium*.

##### Order 2. Batoidea or Hypotremata

1. Body depressed. Pectoral fins enlarged, joined to sides of head and body.
2. Gill slits ventral, five pairs.  
Ex. Rays. *Pristis*, *Rhinobatus Raja*, *Torpedo*, *Trygon* (= *Dasyatis*), *Urobatus*, *Aetobatus* and *Myliobatis*.

##### Sub-class B. Brachyodonti —Fossil and recent fishes.

##### Order 1. Eubrachyodonti

Ex. Extinct fishes.

##### Order 2. Holocephali

1. Gill slits covered by fleshy operculum and a single gill opening.
2. Tail whip like, spiracles, cloaca and scales absent.  
Ex. *Hydralogus* (= *Chimaera*)

#### CLASS 3. OSTEICHTHYES

1. Skeleton chiefly of bone (Cartilage in sturgeon)
2. Skin with many mucous glands with embedded bony dermal scales (Cycloid, ctenoid or ganoid).

##### Sub-class A. Actinopterygii

1. Ray-finned fishes. Paired fins thin, broad, without fleshy basal lobes and supported by dermal fin rays.
2. Nostril not connected to mouth cavity except in stargazer.

##### Superorder I. Chondrostei

1. Primitive ray-finned fish or cartilaginous ganoids.
2. Tail fin heterocercal.

##### Order 1. Polypteriformes

1. Body slender. Scales thick ganoid and rhombus.
2. 8 or more dorsal fins, each preceded by a spine. Caudal fin arrow shaped.  
Ex. *Polypterus*.

##### Order 2. Acipenseriformes

1. Snout long or paddle shaped.
2. 8 rows of bony ganoid scutes or body naked with few vestigial scales.  
Ex. *Acipenser*, *Polyodon*.

##### Superorder II. Holostei

1. Intermediate forms between Chondrosteian and teleost fishes.
2. Scales ganoid. Ray finned fishes.

##### Order 1. Amiiformes

1. Snout normal. Dorsal fin long. Tail fin short.
2. Scales thin, Overlapping and cycloid.  
Ex. *Amia* (bow fin).

##### Order 2. Lepidostiformes

1. Snout and body elongated.
2. Scales rhomboidal, ganoid, in oblique rows.  
Ex. *Lepidosteus*.

##### Superorder III. Teleostei

1. Light skeleton. Density of bones reduced. Ganoid scales reduced or absent.
2. Swim bladder hydrostatic.
3. Modern ray-finned fishes.

##### Order 1. Clupeiformes

1. Silvery compressed marine fishes. Scales cycloid.
2. Air bladder connects to pharynx. Tail fin homocercal. Pelvic fin abdominal.  
Ex. *Clupea*, *Salmo*, *Tarpon*, *Sardinops* and *Esox*.

**Order 2. Ostariophysi or Cypriniformes**

1. Air bladder communicates to pharynx.
2. Weberian ossicles between air bladder and internal ear.

Ex. *Characius*, Electric eels, Suckers, Minnows, Catfishes, *Labeo*, *Mystus*, *Notopterus*, *Electrophorus*, *Cyprinus*, *Barbus*, *Arius*, *Clarius*, *Wallago*, *Catla*, *Heteropneustes*.

**Order 3. Ophiocephaliformes**

1. Head depressed with plate like scales.
2. Air bladder long without duct.
3. Accessory respiratory organs present.

Ex. *Ophiocephalus* (= *Channa*)

**Order 4. Anquilliformes**

1. Eels. Body long and slender.
2. Dorsal, caudal and anal fins continuous. Pelvic fins absent.

Ex. *Anguilla*, *Muraena* and *Amphipnous*.

**Order 5. Beloniformes or Syngnathini**

1. Pectoral fins large and high on body.
2. Scales cycloid.

Ex. Flying fishes. *Exocoetus*, *Belone*, *Cypselurus*, *Scomberesox*.

**Order 6. Syngnathiformes or Solenichthyes**

1. Snout tubular with suctorial mouth. Swim bladder closed.
2. Bony rings or protective scales over body.

Ex. *Hippocampus*, *Hemirhamphus*, *Xenentodon*, *Syngnathus*, *Fistularia*.

**Order 7. Perciformes or Percomorphi**

1. Trout perches. Dorsal and anal fins preceded by 1 or 4 spines. Pectoral fin well up on sides.
2. Weberian apparatus absent. Air bladder without duct.

Ex. *Anabas* (Climbing perch), *Perca*, *Lates*, *Huga*, *Lepomis*, *Scomber*.

**Order 8. Pleuronectiformes**

1. Asymmetrical head with both eyes on one side.

2. Body strongly compressed. Dorsal and anal fins fringing the body.

Ex. *Pleuronectes*, *Hippoglossus*, *Achirus*, *Synaptura*, *Solea*.

**Order 9. Tetrodontiformes (= Plectognathi)**

1. Body shape variable. Some globose.
2. Strong jaws with sharp teeth. Scales generally spiny.

Ex. *Ostracion*, *Diodon*, *Tetradon*, *Molamola*, *Fieraster*.

**Order 10. Echeiniformes**

1. Dorsal fin modified into flat, oval, adhesive disc on upper surface of head.

2. Scales cycloid. Air bladder absent.

Ex. *Echeneis* or *Remora*.

**Order 11. Lophiiformes**

1. Dorsal fin like flexible spines.

2. First dorsal spine located on head with tip modified into lure. Mouth wide.

Ex. *Lophius*, *Antennarius*.

**Sub-class B. Sarcopterygii (= Choanichthyes)**

1. Paired fins leg like or lobed with a fleshy bony central axis covered by scales.

2. Dorsal fin 2, caudal fin heterocercal with an epichordal lobe.

3. Olfactory sacs usually connected to mouth cavity by internal nostrils or choanae.

**Order 1. Crossopterygii**

1. Lobed finned fishes.

2. Premaxillae and maxillae present. Teeth well developed and conical.

Ex. *Latimeria*.

**Order 2. Dipnoi**

1. Lung fishes. Air bladder paired lung like.

2. Median fins continuous to form diphyccercal tail.

Ex. *Lepidosiren*, *Protopterus*, *Neoceratodus*.

## SUPER CLASS PISCES (=FISHES)

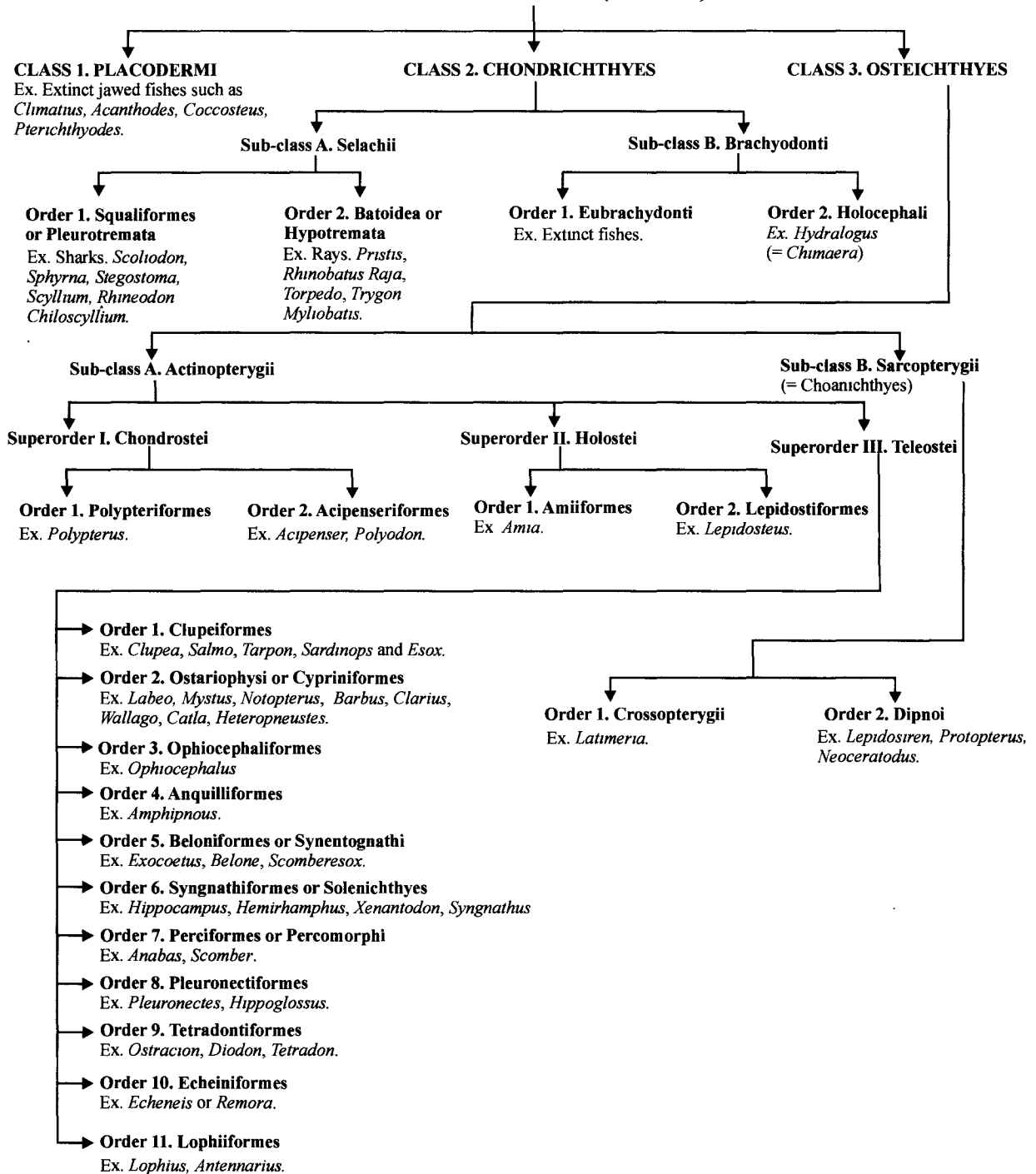

## CLASS CHONDRICHTHYES CARTILAGINOUS FISHES

### Natural history

Skeleton is made of cartilage. Most sharks and rays are marine, but a few live in tropical rivers above salt water. Sharks live in open water, and rays on the bottom. The sharks are predaceous, active swimmers and feed on small fishes. Sharks and rays are used as human food in many countries. Shark liver contains much oil rich in vitamin A. Sharks are also a nuisance to

fishermen, because they tear nets and steal captured fishes. Large sharks may capsized small boats and injure or kill fishermen. Living fishes probably exceed 20,000 species, an abundance and diversity unequalled among all other vertebrates. They originated 530 million years ago allowing vast span of time for evolutionary divergence and for origin and extinction of major phyletic lines.

### 16. *Scoliodon* : Dogfish

#### Classification :

Phylum.....	Chordata	→	Dorsal tubular nerve cord, notochord and gill-slits present.
Group.....	Craniata	→	Cranium with brain present.
Subphylum.....	Vertebrata	→	Vertebral column present.
Division.....	Gnathostomata	→	Jaws and paired appendages present.
Superclass.....	Pisces	→	Paired fins, gills and skin with scales.
Class.....	Chondrichthyes (=Elasmobranchi)	→	Endoskeleton cartilaginous. Scales usually placoid. Spiral valve in intestine. Opercula absent.
Sub-class.....	Selachi	→	Sharks and rays. Gills in separate clefts. Cloaca present.
Order.....	Pleurotremata (=Squali)	→	( <i>Pleuro</i> , sides; <i>trema</i> , opening). Gill-slits lateral, pectoral fins small.
Family.....	Scyllidae	→	Asterospondylus. First dorsal fin without spine.
Genus.....	<i>Scoliodon</i> (Dogfish)		

**Geographical distribution :** *Scoliodon* has wide distribution. About 4 species are found all along the Indian sea coast. Its presence has been reported from Zanzibar, Srilanka to Malay Archipelago, East Indies, Philippine Islands, Mexico to Panama, Cuba, West Indies and South America. Lower Carboniferous to Recent.

**Habit and habitat :** The natural home of *Scoliodon* is the sea, but some live in **estuaries** and even ascend the rivers. They are **predacious** and **voracious** feeders attacking their prey with powerful jaws. They are active swimmers.

#### Comments :

- (1) Commonly called **dogfish** or **dogshark**.
- (2) Spindle-shaped body, about **60 cm long**, is regionated into **head**, **trunk** and **tail**.
- (3) Dorsal and lateral sides of body are pigmented dark grey or slaty grey, while the ventral side is white.
- (4) **Head** is dorso-ventrally compressed and flattened into snout. It contains ventrally situated slit-like **mouth**, obliquely situated nostrils and laterally situated **protuberant eyes**. A little behind eyes there are five pairs of lateral **gill-clefts**.
- (5) **Trunk** bears paired fins. A pair of anterior **pectoral fins** and a pair of posterior **pelvic fins**.
- (6) **Heterocercal tail** turned upwards and **caudal fin**.
- (7) A pair of pigmented **lateral lines** extends from head to tail.
- (8) *Scoliodon* exhibits **sexual dimorphism**. Males are easily recognized by having a pair of intromittent organs, called as **claspers**. **Cloaca** is found between 2 pelvic fins.

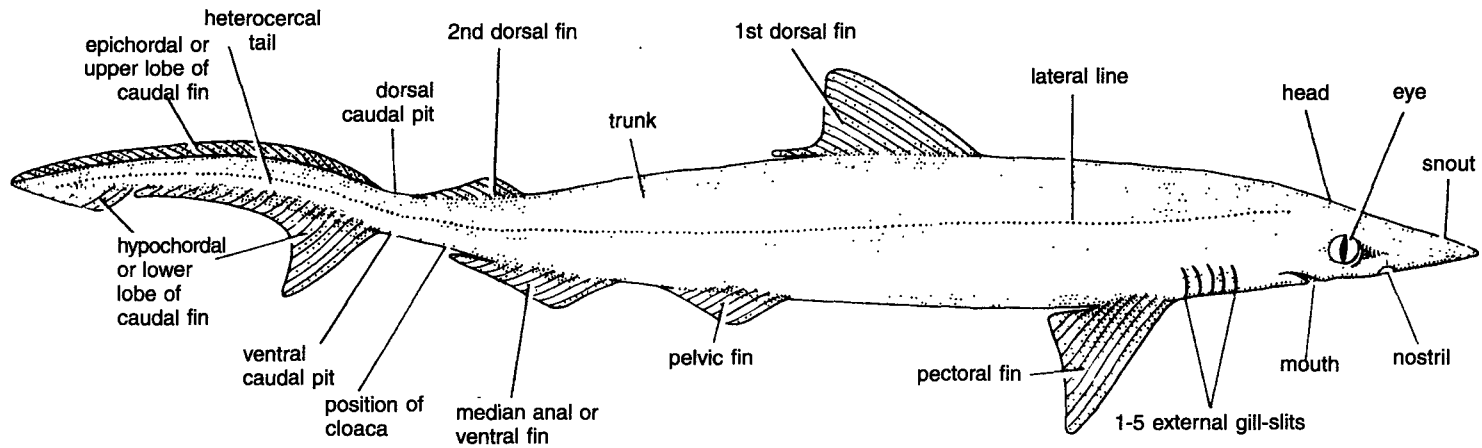

Fig. 16. *Scoliodon*.

**Economic importance :** *Scoliodon* has great **educational** and **experimental** value because of its availability and size and is a favourite dissection fish for undergraduate students.

**Special features :** Sharks are used as **human food** in many countries. Shark's fins are dried and then boiled to yield a gelatinous substance favoured for soups. The tanned shark skin **shagreen** is used to case fine books, jewel boxes and sword handles, etc. Sharks are nuisance to fishermen, because they tear nets, steal captured fishes and take out bait or fish from hooks.

**Identification :** Since the animal has raised tail, pointed snout, and above features, hence it is *Scoliodon*.

### 17. *Scoliodon* : Embryo with Yolk Sac Placenta

**Comments :**

- (1) *Scoliodon* is ovoviviparous.
- (2) Eggs develop inside uteri and they give birth to living young, 3 to 7 embryos.
- (3) Mucous lining of uterus forms a protective fluid-filled chamber for each embryo.
- (4) In the beginning gut of each embryo is connected by a tubular **yolk stalk** with a **yolk sac placenta**.
- (5) Later on, when blood vessels develop, the tubular connection of yolk stalk with **embryo** disappears and instead the embryo is attached to uterine wall by a **placental cord** which gives off several numerous slender tubular outgrowths called as **appendicula** and **yolk sac placenta**.

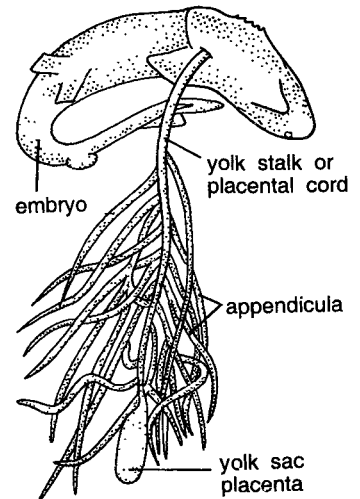

Fig. 17. *Scoliodon*. Embryo with yolk sac placenta.

### 18. *Chiloscyllium* : True dogfish

**Classification :** Same as in *Scoliodon*.

Genus..... *Chiloscyllium*

**Geographical distribution :** *Chiloscyllium* is abundantly distributed in temperate and tropical sea water. It ranges from Cape of Good Hope to Indian Ocean, Australia, China and Japan. Lower Carboniferous to Recent.

**Habit and habitat :** *Chiloscyllium* is a marine shark, found at a depth of about 400 fathoms.

**Comments :**

- (1) Commonly called as true **dogfish** of moderate size.
- (2) Body is laterally compressed and differentiated into **head**, **trunk** and **tail**.

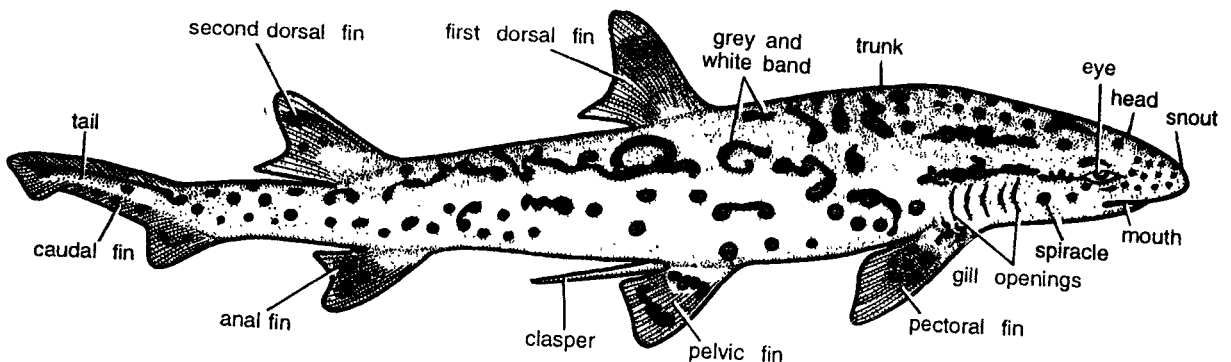

Fig. 18. *Chiloscyllium*.



- (3) Surface of body is mottled with grey and white bands.
- (4) Head is produced into snout and comprises ventral **mouth**, **nostrils** and **eyes** without nictitating membrane. Spiracle and gill openings are found behind eyes.
- (5) Mouth contains small teeth provided with median cusps.
- (6) Median fin consists of **first** and **second dorsal fins** are found behind pelvic and **anal fins**, respectively. Paired fins are **pectoral** and **pelvic**.
- (7) **Tail** is very slightly curved upwards and possess **caudal fin**.
- (8) It is sexually dimorphic. Males have **claspers** which act as intromittent organ.
- (9) Fertilization internal.
- (10) It is **oviparous**. Egg-case is large, quadrate and with tendrils for attachment.

**Economic importance :** Very important to fisheries as its liver contains oil rich in **Vitamin A**.

**Special features :** This fish secretes **Mermaid's purse** or case. The eggs are extremely yolky and as they pass down the oviduct, become surrounded by watery albumen and then by horny mermaid's case. Each case is roughly rectangular with four long coiled filaments. Females lay egg cases among sea weeds. The filaments of the egg cases become entangled with the sea weeds soon after their emergence from the cloaca. In this condition they remain as such till the young ones come out.

**Identification :** Since this fish has grey and white bands and above features, hence it is **Chiloscyllium**.

## 19. *Stegostoma* : Tiger Shark

**Classification :** Same as in *Scoliodon*.

Genus..... *Stegostoma*

**Geographical distribution :** *Stegostoma* is abundantly found in the Indian Ocean. Lower Carboniferous to Recent.

**Habit and habitat :** *Stegostoma* is found in open water. It is an **active swimmer** and predaceous. It feeds on crabs, fishes and turtles, etc.

**Comments :**

- (1) *Stegostoma* is commonly called as **Tiger shark** or **Zebra shark** because of the handsome and brilliant colouration of dark stripes over yellow ground.
- (2) **Coloured stripes** of anterior region are very distinct.
- (3) It measures 3 to 5 metres in length.
- (4) Body is elongated, laterally compressed and regionated into **head**, **trunk** and **tail**.
- (5) **Head** as long as broad, **snout** reduced.

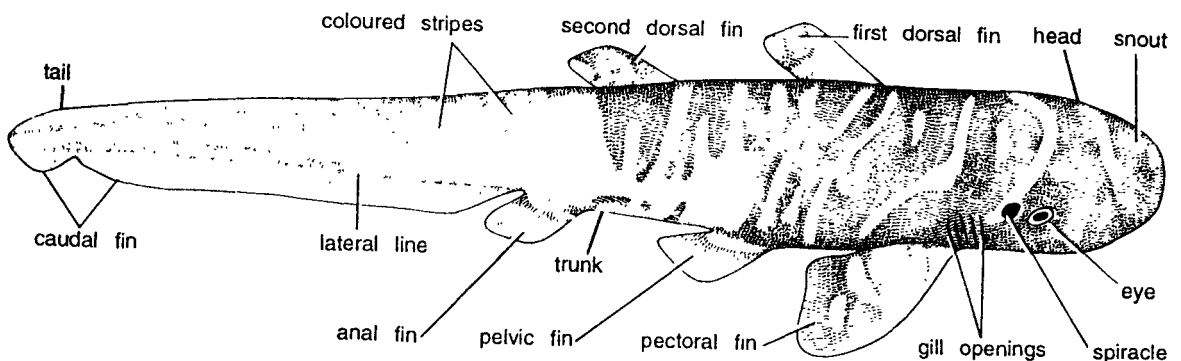

Fig. 19. *Stegostoma*.

- (6) Transverse ventral mouth is found under the surface of the head.
- (7) **Eyes lateral**, without nictitating membrane. **Spiracles** distinct, present behind the eyes.
- (8) Gill-slits 5 pairs in lateral position.
- (9) Fins are **first dorsal fin**, **second dorsal fin**, **paired pectoral** and **pelvic fin**, **anal fin** and **caudal fin**.
- (10) Tail heterocercal.

**Special features :** **Tiger shark** is **viviparous**. It is also a nuisance to fisheries because it destroys small fishes. **Tiger** or **Zebra shark** is famous for its brilliant colouration and ferocious attack.

**Identification :** Since this fish has coloured stripes and above features, hence it is *Stegostoma*.

## 20. *Sphyrna* : Hammer-headed Shark

**Classification :** Same as in *Scoliodon*.

Genus..... *Sphyrna*

**Geographical distribution :** *Sphyrna* is found in all **tropical** and **sub-tropical** sea waters and Pacific Ocean, primarily in warm coastal waters. **Lower Carboniferous to Recent**.

**Habit and habitat :** *Sphyrna* or *Zygaena* or *Reniceps* is a common marine fish, adapted for **deep sea** waters. It is a voracious feeder and **active** swimmer. It eats small fishes, but because of its attacks on man, it is dreaded as **man-eater**.

**Comments :**

- (1) Commonly called as **hammer-headed shark** due to the hammer-shaped head, which is produced into two prominent lateral lobes supported by corresponding cartilaginous outgrowths from post-orbital or lateral ethmoidal regions of skull. **Eyes** containing nictitating membrane are placed at the distal extremities of the lateral lobes.
- (2) Elongated body measuring 4 to 5 metres is divided into **head**, **trunk** and **tail**. The tail is raised upwards and contains caudal fin.
- (3) Dorsal side is greyish while ventral side is yellowish.
- (4) **First dorsal fin** is situated in front of **pelvic fin** and **second dorsal fin** opposite to **anal fin**. Both fins are devoid of spines. Pectoral fin near gill openings.
- (5) Mouth is crescentic and ventral in position.

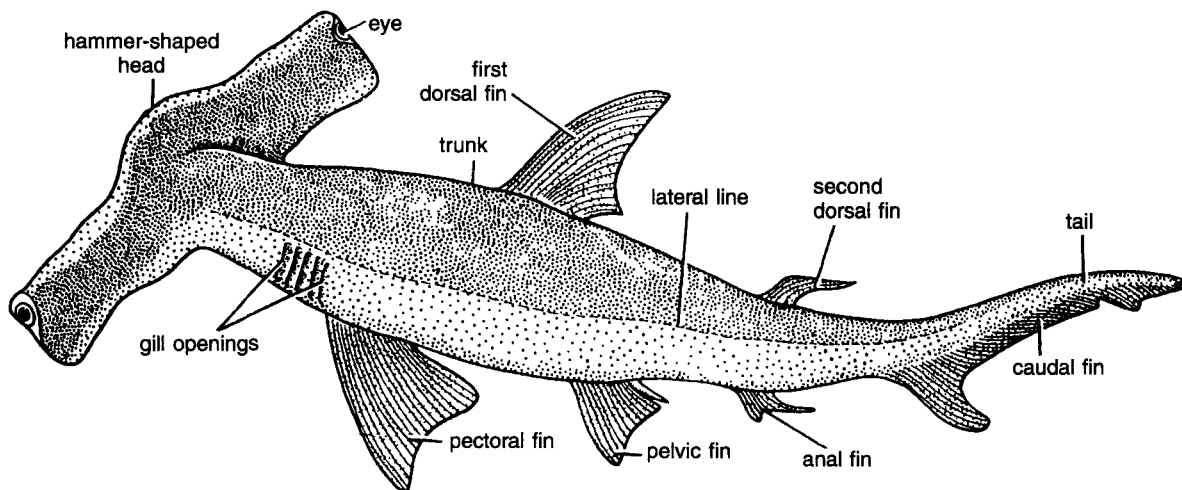

Fig. 20. *Sphyrna*.

- (6) Gill-slits 5 pairs and lateral in position. **Spiracles** are absent. **Lateral line** distinct.  
 (7) Vertebrae **asterospondylus**.  
 (8) Viviparous and produces about 40 young ones.

**Special features :** **Hammer-headed sharks** are closely related to carcharhininae but differ in many cranial characters associated with sphyrnid cephalic '**hydrofoil** or **hammer**.' Large sharks are highly dangerous and there are many records of fatal attacks on humans. *S. zygaena*, *S. blochi*, *S. tiburo* are some common species.

**Identification :** Since this fish has hammer-shaped head and above features, hence it is *Sphyrna*.

## 21. *Torpedo* : Electric Ray

### Classification :

Phylum.....	Chordata	→	Dorsal tubular nerve cord, notochord and gill-slits present.
Group.....	Craniata	→	Cranium with brain present.
Subphylum.....	Vertebrata	→	Vertebral column present.
Division.....	Gnathostomata	→	Jaws and paired appendages present.
Superclass.....	Pisces	→	Paired fins, gills and skin with scales.
Class.....	Chondrichthyes (= Elasmobranchi)	→	Endoskeleton cartilaginous. Scales usually placoid. Notochord rudimentary. Spiral valve in intestine. Opercula absent.
Sub-class.....	Selachi	→	Sharks and rays. Gills in separate clefts. Cloaca present.
Order.....	Hypotremata (= Batoidea)	→	Gills-slits ventral. Spiracles present. Dorsal fin on tail, if present. Vertebrae tectospondylous.
Family.....	Torpidinidae	→	Trunk forms a broad and smooth disk, contains electric organs.
Genus.....	<i>Torpedo</i> (Electric ray)		

**Geographical distribution :** *Torpedo* has been reported from the Mediterranean, Atlantic and Indian Oceans, Red Sea, Pacific Ocean, East Indies, Tasmania, China, Japan, South Africa, North and South America as well as Australia. Upper Jurassic to Recent.

**Habit and habitat :** *Torpedo* or *Astrape* is a marine fish, found on flat, sandy or **muddy bottom** at a depth of 40 to 50 fathoms. It is **carnivorous**.

### Comments :

- (1) Commonly known as **Electric ray** because of the presence of a pair of **electric organs**, one on either side of the body between head and the pectoral fins (Fig. 17).
- (2) Body is regionated into anterior **semicircular disk** supported by endoskeleton and **posterior tail**. Fish measures 60 to 90 cm across the widest part of the disk and the whole body has brown background which is ornamented with beautiful irregularly shaped, magenta-coloured **spirals** and spots.
- (3) Semicircular region is supported by branched prenasal **rostrum** and laterally by branched pre-orbital cartilages. Branches radiate towards periphery.
- (4) Disk is bordered by **pectoral fins**.
- (5) Skin is smooth, **non-tuberculate** and without **scales**.
- (6) **Eyes** and **spiracles** are closely placed above electric organs dorsally.
- (7) **Mouth** is transverse and ventrally situated.
- (8) **Tail** is thick and short with two **dorsal fins**, a **caudal fin** and two **lateral folds** of skin. **Pelvic fins** are just beneath the lower margin of the **pectoral fin**.
- (9) **Gill-slits** on the ventral side.
- (10) Viviparous and produces live youngs.

**Special features :** (i) *Torpedo* contains a pair of large **electric organs** between margins of pectoral fins and head. These organs are considered as modifications of the adductor mandibulate and constrictor muscles and supplied by vagus and trigeminal nerves from vagus and trigeminal nerves from electric lobe of the medulla, (ii) Each electric organ is composed of hexagonal cells called as **electroplexes**

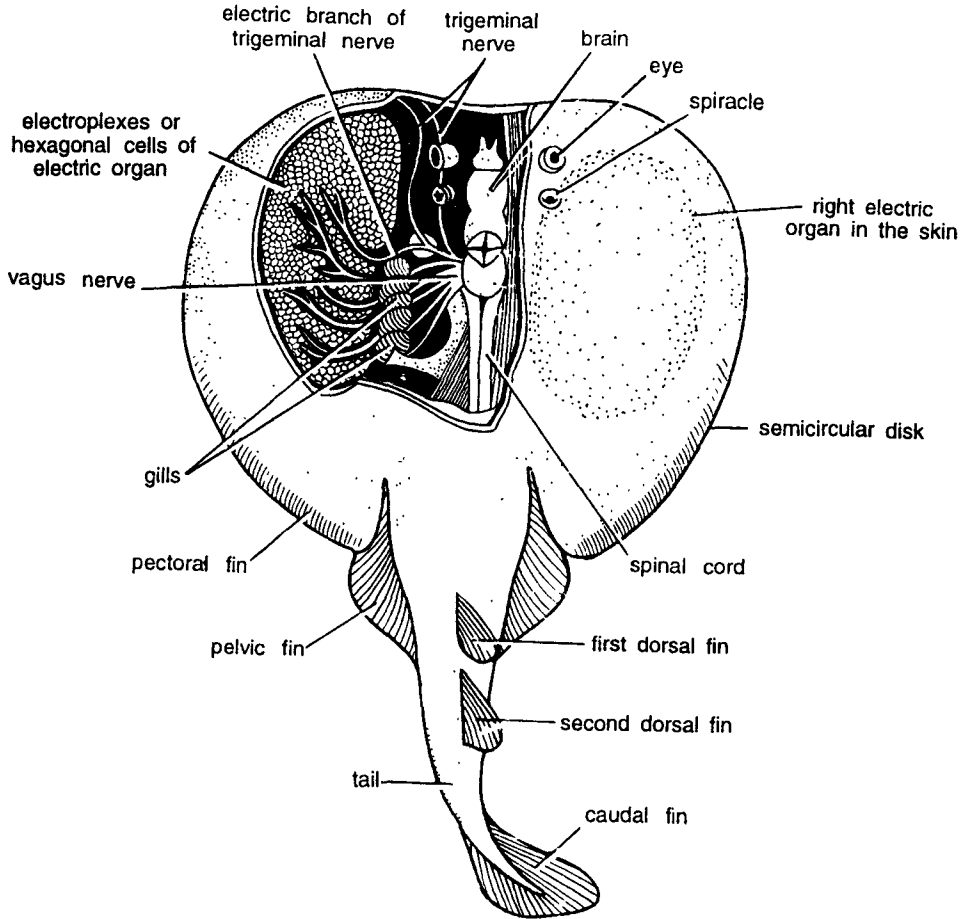

Fig. 21. *Torpedo* or Electric ray.

which are filled with jelly-like fluid and arranged vertically like prisms between upper and lower surfaces. Upper surface corresponds to **anode** and lower surface with the **cathode**. Thus, **electric current of 50 to 60 volts passes from** upper positive to lower negative surface. After fish has discharged electricity, some rest is required for further discharge. These are **offensive** and **defensive** organs and fishermen get electric shocks from captured electric rays.

**Identification** : Since this fish has 2 bulging electric organs and above features, hence it is *Torpedo*.

## 22. *Pristis* : Saw Fish

**Classification** : Same as in *Torpedo*.

Family.....Pristidae

Genus.....*Pristis*

**Geographical distribution** : *Pristis* is found in tropical and sub-tropical regions. Indian form ascends beyond tidal zones. It is reported from America, Gulf of Mexico, Lower Mississippi, the Mediterranean sea and Atlantic waters. Upper Jurassic to Recent.

**Habit and habitat** : *Pristis* is a warm water marine type. It is **predacious**, feeding on small fishes and other marine animals by slashing them with its saw. It often ascends the river.

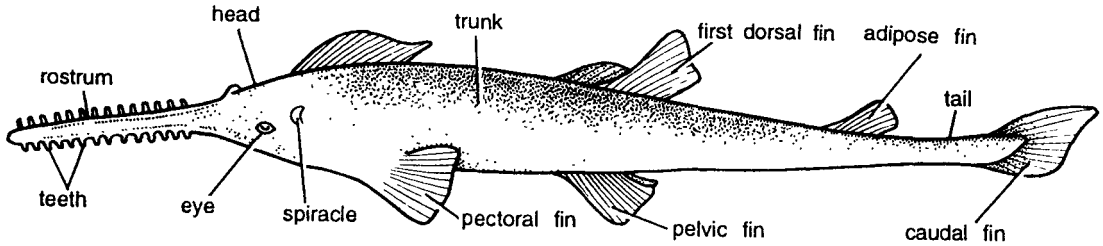

Fig. 22. *Pristis* (Saw fish).

**Comments :**

- (1) Commonly called as **saw-fish**, weighing 350 to 1200 Lbs and measuring 3 to 6 metres in length.
- (2) Elongated, shark like body is slightly depressed and divided into **head, trunk and tail**.
- (3) **Body shape** is midway between a shark and a ray. The anterior part is flattened dorsoventrally and is ray-like while the posterior part, for more than half, is shark-like. It exhibits close relationship with rays.
- (4) **Head** contains a pair of **eyes** and a pair of **spiracles** behind the eyes. Water passes through the spiracles and goes out through the gill-slits.
- (5) **Snout** is anteriorly produced into a **saw-like rostrum** with large and small weakly embedded **teeth**.
- (6) **Mouth** is on the ventral side of the head.
- (7) **Tail** is well developed and ends in a **heterocercal caudal fin**.
- (8) **Dorsal fins are large. First dorsal fin is opposite to pelvic fin.** Second dorsal fin is called as **adipose fin**. Paired fins are **pectoral and pelvic**. Tail contains **caudal fins**.

**Economic importance :** The fish is also economically very beneficial as its **liver oil** is rich in vitamin value and its skin for making scale boards.

**Special features :** (i) The important structure is 'saw-like' **snout**, which is formed by the elongation of head and skull. They are flattened in the form of a **rostrum**, which contains a series of tooth-like 16 to 32 pairs of denticles on the lateral margins, (ii) The teeth are fixed in sockets, in the calcified rostral cartilage, (iii) The rostrum acts as an organ of offence and defence, (iv) ***Pristis*** is capable for **retaining urea** in fresh-water while ascending in rivers.

**Identification :** Since this fish has saw-like toothed snout and above features, hence it is ***Pristis***.

### 23. *Rhinobatus* : Guitar Fish

**Classification :** Same as in *Torpedo*.

Family..... *Pristidae*

Genus..... *Rhinobatus*

**Geographical distribution :** *Rhinobatus* has been reported from west coast of Africa, Indian Ocean, Australia, China, Atlantic and Pacific coasts of America and Galapagos. Mostly distributed in tropical and sub-tropical seas. Upper Jurassic to Recent.

**Habit and habitat :** It is a **bottom dweller**.

**Comments :**

- (1) **Commonly** called as **Guitar fish**, due to its guitar-like shape. Body divided into **head, trunk and tail**.
- (2) Sub-rhombic head tapers into a triangular **snout** or rostrum.
- (3) **Pectoral fins** greatly expanded along the **head and trunk** and consequently body assumes sub-rhombic shape.
- (4) Entire back contains a median row of **minute denticles**.
- (5) **Head and body** are dorsoventrally compressed.

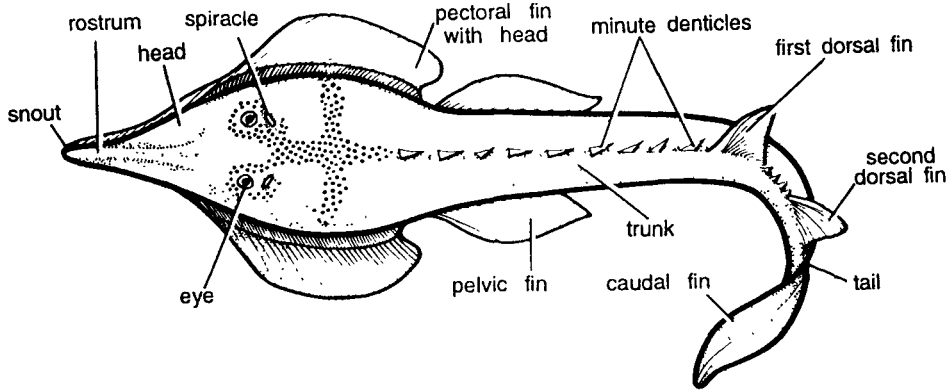

Fig. 23. *Rhinobatus* (Guitar fish).

- (6) **Head** contains a pair of **eyes** and a pair of **spiracles** closely placed to eyes.
- (7) **Gill-slits** 5 pairs, situated ventrally.
- (8) **Tail** is elongated with a **caudal fin** and a longitudinal fold of skin on each side.
- (9) Paired **pelvic fins** near pectoral fins. First and second dorsal fins near tail region.
- (10) **Viviparous**.

**Economic importance :** It has edible value.

**Special features :** The fish exists from Upper Jurassic. The complete skeleton of *Rhinobatus* has been obtained from lithographic stone of Bavaria. Upper Cretaceous of Mount Lebanon and Upper Eocene of Monte Bolca. Body **intermediate** between shark like and skate like.

**Identification :** Since this fish has guitar-shaped body and above features, hence it is *Rhinobatus*.

## 24. *Raja* : Skate

**Classification :** Same as in *Torpedo*.

Family.....Rajidae

Genus.....*Raja*

**Geographical distribution :** *Raja* is found in almost all temperate sea waters. Most of the species belonging to the genus *Raja* are abundantly distributed in northern hemisphere, Arctic and Antarctic regions. Upper Jurassic to Recent.

**Habit and habitat :** *Raja* is marine, sluggish, **bottom-dwelling** fish. It is **carnivorous**, feeding on small fishes and crustaceans. They catch their prey by dropping over them and covering prey from all sides from their body and fins.

**Comments :**

- (1) Commonly known as **skate**, measuring 2 to 3 metres in width.
- (2) **Body** is dorsoventrally flattened, rhomboidal and differentiated into anterior **rhombic disk** and a **slender tail**.
- (3) Colouration of upper surface resembles with sandy or gravelly environment of bottom. Skin slender and provided with spines. Body divided into head, trunk and tail.
- (4) Disc is made up by the **head**, **trunk** and confluent **pectoral fins**. There are rows of tiny spines over the disc and a median row over the tail.
- (5) **Head** produced in a short **snout** with a pair of dorsal **eyes**. **Spiracles** are found just below the eyes.
- (6) Ventral **mouth** provided with numerous sharp, rasping teeth for tearing the prey.
- (7) Slender **tail** distinctly demarcated from the rhombic disk.
- (8) Fins-paired pectoral and pelvic fins present. **First dorsal fin** and **second dorsal fins** near **caudal fin**.

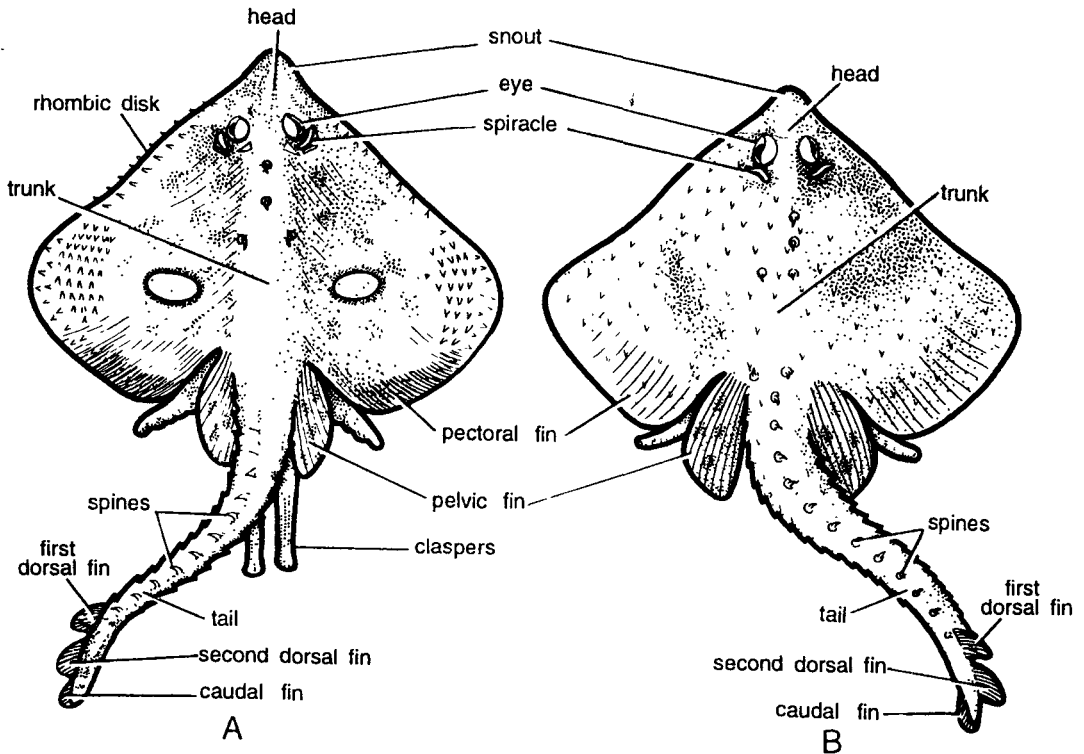

Fig. 24. *Raja*. A. Male, B. Female.

(9) Sexually **dimorphic**. Male is provided with a pair of **claspers** near the pelvic fin.

(10) **Oviparous**, egg capsules four-horned.

**Special features** : The **pectorals fins** are greatly expanded. They are endoskeletally supported and they extend along the lateral margins of the trunk from the pelvic fins upto the snout. **Tail** contains one **median** and two **additional rows of small spines** which inflict severe and irritating wound.

**Identification** : Since this fish has rhomboid disk, fused pectoral fins and above features, hence it is *Raja*.

## 25. *Trygon* (= *Dasyatis*) : Sting Ray

**Classification** : Same as that of *Torpedo*.

Family.....Rajidae

Genus.....*Trygon*

**Geographical distribution** : *Trygon* is abundantly distributed in tropical regions of the Atlantic and Pacific Oceans. It has been reported from India, Japan, China, North America, Australia and South America. Upper Jurassic to Recent.

**Habit and habitat** : *Trygon* is found lying quietly on the sea bottom. It occasionally swims to change the place in search of prey or moves in self-defence. It is **carnivorous** feeding on small fish, crustaceans and molluscs. It also shows adaptive or protective colouration to conceal itself from the enemies.

**Comments** :

- (1) Commonly called as **sting ray** or **whip-tailed ray** because of the presence of 3 **stings** or **spines** in tail. Body divisible into **head**, **trunk** and **tail**.
- (2) It consists of huge kite-shaped **fleshy body** and long **whip-like tail**. **Head** and **body** dorsoventrally compressed.

- (3) Outer anterior margin of pectorals continuous along side of head upto end of snout forming sub-rhombic disc-shaped body. Disc less than 1.3 times as broad as long.
- (4) Paired **pectoral fins** being confluent with the sides of the head. Paired **pelvic fins** small.
- (5) **Skin** is smooth or spiny.
- (6) **Mouth** is ventral and rectangular. Nasofrontal flap is present in front of the mouth.
- (7) **Head** contains a pair of dorsal **eyes**.
- (8) **Spiracles** present behind the **eyes**.
- (9) **Gill-slits 5 pairs**, ventral in position.
- (10) **Viviparous**. Long glandular filaments are formed in the uterine wall. During development of the embryo, the uterine filaments secrete a nutritive milky fluid which serves as food for embryo.

**Economic importance :** The fish is edible and its liver gives oil.

**Special features :** Sexually **dimorphic**. Male contains **claspers** near the pelvic fins. The **tail** is especially elongated, whip like and contains a large mid-dorsal **poisonous spine** which is a modified dorsal fin. The poisonous spine is about 20 to 35 cm long and acts as organ of offence and defence. Caudal fin is small and single lobed. By **poisonous sting** it inflicts wound on the **victim**. The sting with poison gland produces ugly, slow-healing wound, sometimes complicated by **gangrene** or **tetanus** on **bathers** and **fishermen**.

**Identification :** Since this fish has whip-like tail and above features, hence it is *Trygon*.

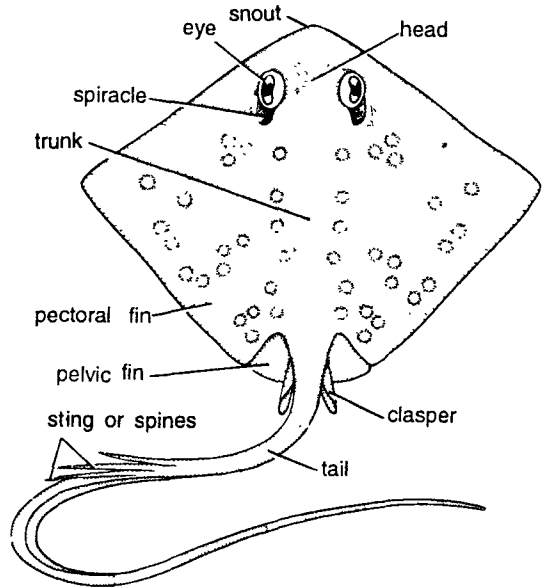

Fig. 25. *Trygon*.

## 26. *Myliobatis* : Eagle Ray

**Classification :** Same as in *Torpedo*.

Family.....*Myliobatidae*

Genus.....*Myliobatis*

**Geographical distribution :** *Myliobatis* is found in tropical and sub-tropical regions, in Mediterranean and eastern and southern coasts of England. Upper Jurassic to Recent.

**Habit and habitat :** *Myliobatis* is found in sea water. It is **viviparous** and **carnivorous**. It feeds on small organisms, crustaceans and molluscs.

**Comments :**

- (1) Commonly known as **Eagle ray**.
- (2) Body consists of a disk and narrow **tail**. Disk is much broader than long and **rhombic in shape**. Body is dorsoventrally flattened. Body divisible into **head**, **trunk** and **tail**.
- (3) Skin non-tuberculate and devoid of scales.
- (4) Paired **pectoral fins** are enlarged but they do not continue with the snout; they cease on the sides of the head and reappear in front of snout as distinct folds, called as **cephalic fins**. Dorsal and pelvic fin small and caudal fin indistinct.
- (5) **Head** is elevated and distinct from disc and contains indistinct **snout**.
- (6) **Eyes** and **spiracles** are lateral in position.
- (7) **Nasofrontal** fold is present.



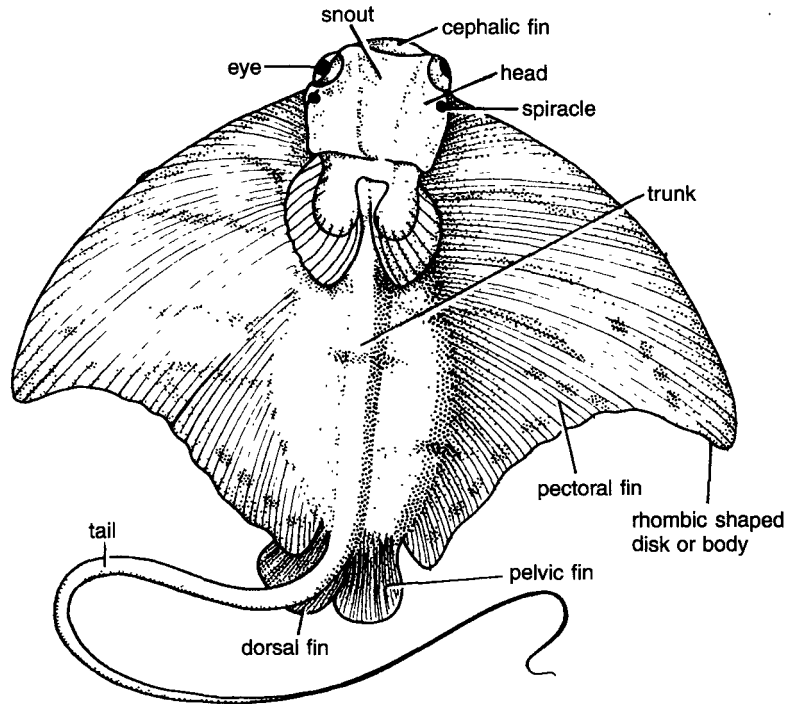

Fig. 26. *Myliobatis*.

- (8) **Teeth** are flat, hexagonal and **adapted for crushing**.  
 (9) **Tail** is long, cylindrical with a single **dorsal fin** and one or two serrated spines which may be venomous in some.  
 (10) No sexual dimorphism.

**Special features** : Some are famous for their ability to **leap high** into the air from water.

**Identification** : Since this fish has lateral eyes, spiracles and above features, hence it is *Myliobatis*.

## 27. *Chimaera* : Rat Fish

### Classification :

Phylum.....	Chordata	→	Dorsal tubular nerve cord, notochord and gill-slits present.
Group.....	Craniata	→	Cranium with brain present.
Subphylum.....	Vertebrata	→	Vertebral column present.
Division.....	Gnathostomata	→	Jaws and paired appendages present.
Superclass.....	Pisces	→	Paired fins, gills and skin with scales.
Class.....	Chondrichthyes	→	Endoskeleton cartilaginous.
Subclass.....	Bradyodonti	→	Dentition of crushing type.
Order.....	Holocephali	→	Spiracle absent. Operculum present. Skull autostylic with two dorsal fins and an anal fin.
Family.....	Chimaeridae	→	Body elongated and shark-like.
Genus.....	<i>Chimaera</i>		

**Geographical distribution** : *Chimaera* inhabits the European coasts from Norway to Portugal, Japan and North America. Upper Devonian to Recent.

**Habit and habitat** : It is found at the depth of 350 to 2200 metres and eats fish, invertebrates and seaweeds.

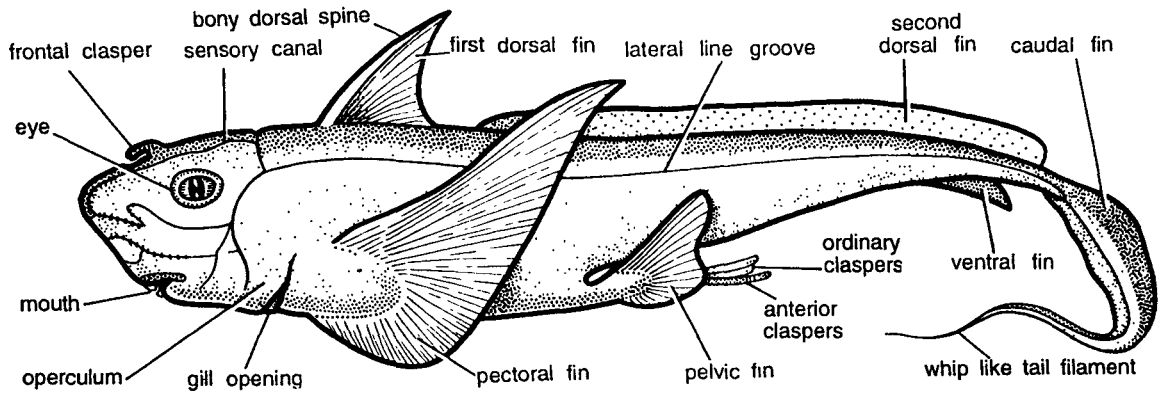

Fig. 27. *Chimaera* (Rat fish).

#### Comments :

- (1) Commonly known as 'Rat Fish' or 'King of Herrings'. Body divisible into **head, trunk and tail**.
- (2) Body is shark-like with compressed **head** and blunt **snout**. Mouth is bounded by lip-like folds. **Mouth** and **nostril** ventral in position.
- (3) **Gill-slits** communicate with the exterior by a single branchial opening below the operculum which is not bony and covers the gills. **Spiracles** absent.
- (4) There are two large **dorsal fins** and a small **ventral fin**. **First dorsal fin** bears an immensely bony anterior erectile dermal **spine** while the **second dorsal fin** is non-erectile. The paired pectoral and pelvic fins are enlarged. Ventral fin small.
- (5) **Caudal fin** is like a folded tail, is produced into whip-like filament and is of diphyceral type.
- (6) **Sexes** are separate. Male *Chimaera* contains five **claspers**, a frontal or **cephalic clasper** on the head, a pair of anterior claspers in front of pelvic fins and a pair of ordinary claspers near pelvic fins.
- (7) **Lateral line** consists of open groove and body surface is smooth and scaleless. Male fish contains **claspers**.
- (8) **Jaw suspension autostylic**.
- (9) Eggs are surrounded by egg shell. Placoid scales are found in young rat fish.

**Special features :** *Chimaera* is important because it shows **selachian** and certain **specialized characters**.

Selachian features comprise of **cartilaginous endoskeleton, selachian limb girdles, dermal denticles, absence of air bladder, presence of spiral valve in the intestine, conus arteriosus and claspers in male**. The **specialized** characters include **autostylic skull, firmly fused palato-quadrates** with the base of **cranium, teeth** in the form of **crushing dental plates** and **five claspers in male**. The fish also reveals tendencies towards the **bony fishes** in having crowded **gill-slits** beneath the head covered by operculum, suppressed spiracles and absence of cloaca. *Chimaera* is an interesting fish, intermediate between **sharks** and **bony fishes**. Like sharks they have a skeleton of cartilage but unlike them *Chimaera* has small fleshy lipped mouth with tooth plates attached to jaw. Spiracles absent. *Chimaera* further resembles the bony fishes in **lacking cloaca** and in having **urinogenital aperture** behind anus.

**Identification :** Since this fish has blunt snout, additional claspers and above features, hence it is *Chimaera*.

## CLASS OSTEICHTHYES BONY FISHES

### Natural history

Bony fishes occur from polar seas to equator, from surface to depths in waters more than 12,000 feet deep. They live variously in open water, sandy, rocky or muddy bottoms, in crannies of reefs, in saline bays, estuaries, fresh alkaline rivers, lakes and cave water, and hot and cold springs. Most fishes migrate from salt water to fresh-water (**anadromous**) and fresh-water to salt

water (**catadromous**) for spawning. They are important human protein food. The class **Osteichthyes** comprises of bony fishes, which are famous for their bony skeleton, scales, plates, air bladder and advanced brains. Various fishes are found in different types of water such as fresh-water, brackish water, salt water, warm water and cold water.

### 28. *Polypterus* : Bichir

#### Classification :

Phylum.....	Chordata	→	Dorsal tubular nerve cord, notochord and gill-slits present.
Group.....	Craniata	→	Definite head. Cranium with brain present.
Subphylum.....	Vertebrata	→	Vertebral column present.
Division.....	Gnathostomata	→	Jaws and paired appendages present.
Superclass.....	Pisces	→	Paired fins, gills and skin with scales.
Class.....	Osteichthyes	→	Bony fishes. Skin contains dermal scales. Paired lateral fins present. Gills, air bladder present. Cleavage meroblastic.
Subclass.....	Palaeopterygii	→	Ancient fishes. Dermal fin rays numerous. Clavicles present. Nostrils free from mouth cavity.
Order.....	Cladistia	→	Body slender, scales thick, rhomboid, enamelled. Air bladder lung like.
Family.....	Polypteridae	→	Pectoral fins lobate, while pelvic fins non-lobate.
Genus.....	<i>Polypterus</i>		

**Geographical distribution :** *Polypterus* is restricted to tropical Africa, the Nile, Nigeria and Congo. Palaeozoic and Recent (none known species).

**Habit and habitat :** *Polypterus* is found in sea water. It becomes active during night. It feeds on small teleosts, batrachians and crustaceans.

#### Comments :

- (1) *Polypterus* is one of the most primitive living **bony fish** and could be easily regarded as living fossil. Body divisible into **head, trunk and tail**.
- (2) **Body** is elongated, cylindrical, measuring 1 metre in length and covered with **rhombic ganoid scales**.
- (3) Surface covering consists of a thin shiny enamel called **ganoin**.
- (4) **Head** is covered with a horny shield containing tubular nostrils and forwardly lying eyes.
- (5) **Spiracles** present.

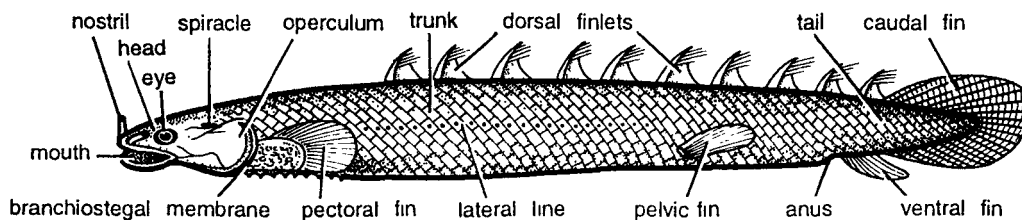

Fig. 28. *Polypterus*.

- (6) There is a fleshy lip on the lower jaw matching that of the upper jaw.
- (7) Dorsal fin consists of a series of 5 to 18 isolated finlets composed of single spine-like scales to which are attached one or more soft rays.
- (8) **Pectoral fins**, found behind head, are broad rounded and lobed at bases. **Ventral fin** backwardly situated. **Pelvic fins** present. Caudal fin diphyccercal.
- (9) Larva possesses plume-like external gills, attached to the hyoid arch, resembling the gills of Amphibian larva.

**Special features :** *Polypterus* shows combination of **primitive** and **advanced** characters. **Primitive** characters are **non-overlapping scales, spiracle, certain skull bones and their arrangement, spiral valve in intestine** and the superficial resemblance of paired fins to broad-based crossopterygian fins. It has also **advanced features** like **dorso-lateral position of nostrils, pyloric caecum in the gut** and similar **urinogenital system**, which bring them closer to **bony fishes**. The tail is no longer **heterocercal**. The **air bladder** though connected with pharynx seems to be respiratory organ but remains non-functional as *Polypterus* cannot live outside water for a longer period.

**Identification :** Since this fish has dorsal finlets and above features, hence it is *Polypterus*.

## 29. *Polyodon* : Paddle Fish

**Classification :**

<b>Phylum.....Chordata</b>	→	Dorsal tubular nerve cord, notochord and gill-slits present.
<b>Group.....Craniata</b>	→	Definite head with cranium and brain.
<b>Subphylum.....Vertebrata</b>	→	Vertebral column present.
<b>Division.....Gnathostomata</b>	→	Jaws and paired appendages present.
<b>Superclass.....Pisces</b>	→	Paired fins, gills and skin with scales.
<b>Class.....Osteichthyes</b>	→	Bony fishes.
<b>Subclass.....Palaeopterygii</b>	→	Ancient fishes.
<b>Order.....Chondrostei</b>	→	Body covered with bony scutes or naked. Tail heterocercal. Skeleton largely cartilaginous. Notochord unsegmented. Vertebrae acentrous.

**Family .....Polyodontidae**  
**Genus .....Polyodon (Polydora)**

**Geographical distribution :** *Polyodon* is found in the rivers of South and North Americas, Mississippi, Ohio and Missouri. Lower Jurassic to Recent.

**Habit and habitat :** *Polyodon* is a marine fish, sluggish and feeding chiefly on mud with minute organisms. The long gill rakers form efficient filter for taking planktonic food. It eats small invertebrates.

**Comments :**

- (1) Commonly known as **spoon bill** or **paddle-fish** because of paddle-like spoon.
- (2) Body is fusiform, measuring 5 to 6 feet. Head is produced into a paddle shaped bill or spoon.
- (3) Spoon is exceptionally elongated, spatulate, conical with rigid axis and flexible margins.

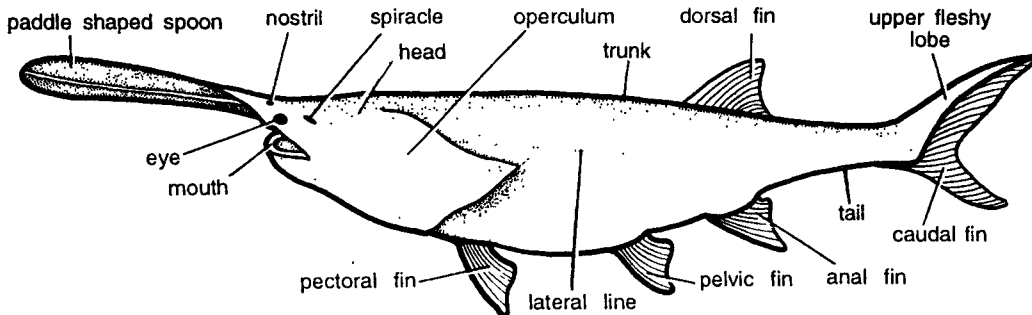

**Fig. 29.** *Polyodon*.

- (4) **Mouth** is wide and ventral.
- (5) **Teeth** minute, spiracles present, gill cover greatly produced posteriorly.
- (6) Paired pectoral and pelvic fins small.
- (7) Dorsal fin opposite to anal fin.
- (8) A poorly-developed **sub-operculum** is present in addition to a small-rayed operculum.
- (9) **Lateral line** distinct.
- (10) Tail **heterocercal** caudal fin bilobed. Upper fleshy to be larger.

**Special features :** *Polyodon* also shows combination of primitive and advanced characters.

**Identification :** Since the fish has spatulate rostrum and above features, hence it is *Polyodon*.

### 30. *Acipenser* : Sturgeon

**Classification :** Same as those of *Polyodon*.

Genus.....*Acipenser*

**Geographical distribution :** *Acipenser* is abundantly distributed in Black Sea, Sea of Azor, Caspian Sea, in rivers of Europe, China and on the Atlantic coasts of North America. Lower Jurassic to Recent.

**Habit and habitat :** *Acipenser* is a marine, **bottom-dwelling fish**. They stir the bottom with their snout in search of small invertebrates, worms, molluscs, small fishes and aquatic plants for feeding. They are **migratory** fishes, **anadromous**, ascending rivers for spawning.

**Comments :**

- (1) Commonly known as **Sturgeon**, measuring 2 to 4 metres in length.
- (2) Body is elongated, cylindrical and bulky and is divided into **head, trunk** and **tail**. In the body scales are represented by five longitudinal rows of **bony scutes** with small intervening ossification. Each plate is provided with a pointed and partly-conical and backwardly-directed spine.
- (3) **Head** is produced ahead as a long flattened **rostrum** or **snout**. It contains a pair of **eyes** and functional **spiracles**.
- (4) Well developed **rostrum** with 4 ventral **barbels** is used to stir the bottom mud in search of small invertebrates. **Barbels** detect the food and direct the rostrum to dig the mud. Food is sucked through the ventral surface of the snout.
- (5) **Mouth** is ventral and transverse and without teeth in jaws.
- (6) Narrow crevices between scutes contain dermal denticles like those of Elasmobranchi.
- (7) Spiracles open and **skeleton cartilaginous**. **Operculum** represented by opercular bone. Dorsal fin single and posteriorly placed. Paired fins are pectoral and pelvic fins. Ventral fin opposite to dorsal fin. Caudal fin bilobed.
- (8) 2 to 3 million eggs are laid by a single fish during the breeding season. The **air bladder** is smooth, oval and contains ciliated epithelium.

**Economic importance :** **Black eggs** of European sturgeons are used to prepare a delicacy called as **caviar**. Their air bladder is used to prepare **isinglass** meant for cleaning **wines** and **beers**.

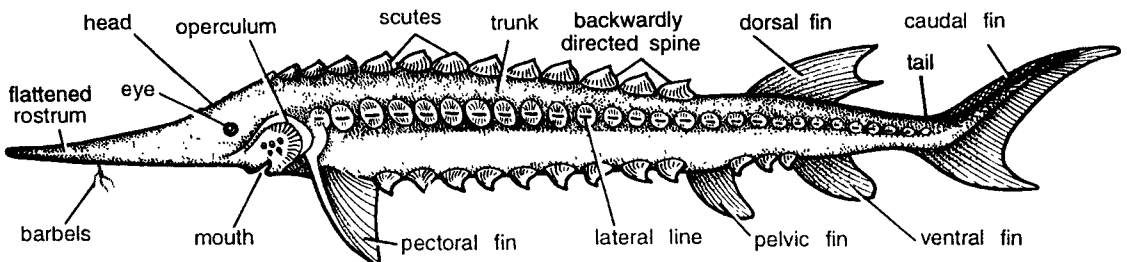

Fig. 30. *Acipenser*.

**Special features :** *Acipenser* shows combination of **primitive** and **secondary** modified characters. They resemble elasmobranchs in having open **spiracles**, **heterocercal** tail, mostly **cartilaginous** skeleton, **spiral valve** in the intestine and conus arteriosus. Loss of **bone** shows secondary character and presence of **rhomboid scales** shows its affinity with ganoid fishes.

**Identification :** Since the fish has 5 rows of bony scutes and above features, hence it is *Acipenser*.

### 31. *Amia calva* : Bowfin

#### Classification :

Phylum.....	Chordata	→	Dorsal tubular nerve cord, notochord and gill-slits present.
Group.....	Craniata	→	Definite head, cranium and brain present.
Subphylum.....	Vertebrata	→	Vertebral column present.
Division.....	Gnathostomata	→	Jaws and paired appendages present.
Superclass.....	Pisces	→	Paired fins, gills and skin with scales.
Class.....	Osteichthyes	→	Bony fishes.
Superclass.....	Actinopterygii or Neopterygii	→	Modern fishes. Vertebrae amphicoelous. Caudal fin homocercal, Scales cycloid or ctenoid. Nostrils do not communicate with mouth cavity.
Super-order.....	Holostei	→	Bony ganoids.
Order.....	Amiiformes	→	Tail heterocercal and overlapping cycloid scales.
Family.....	Amiidae		
Genus.....	<i>Amia</i>		
Species.....	<i>calva</i>		

**Geographical distribution :** *Amia calva* is abundantly distributed in rivers and lakes of Central and Southern America. Upper Jurassic and Lower Tertiary.

**Habit and habitat :** *Amia* is a fresh-water and **carnivorous fish**, feeding voraciously upon other fishes, insects and crustaceans.

#### Comments :

- (1) Commonly known as **Bowfin**, measuring about 60 cm in length.
- (2) Shape of body is fusiform, compressed and divided into **head**, **trunk** and **tail**.
- (3) Body covered by uniformly thin, **overlapping** and nearly **cycloid scales**.
- (4) **Head** contains ventral **mouth** and dorsal **eyes**. The terminal mouth has a thick upper lip and a pair of dorsal barbels.
- (5) **Middorsal fin** has long base and continuous for the greater part of the trunk and tail and contains about 48 rays. All fins short and devoid of fulcra. Paired fins are **pectoral** and **pelvic**. Anal fin near fan-shaped caudal fin.
- (6) **Air bladder** often used as lung. Fish can breath atmospheric air and comes to the surface to engulf air into air bladder. Pyloric caeca absent.
- (7) Tail is **homocercal**, lateral line distinct.

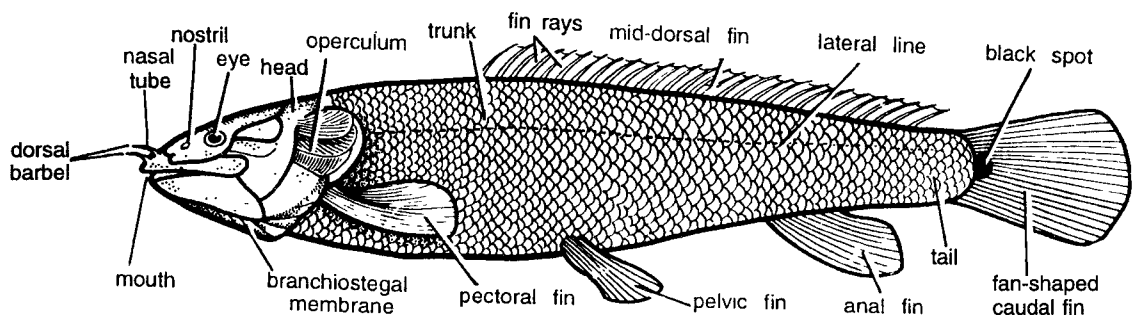

Fig. 31. *Amia calva* : Male.

- (8) **Sexually dimorphic.** Males are smaller than females (45 cm) and provided with a rounded **black spot** at the base of caudal fin. Two peculiar comb-like structures are found on the head.
- (9) Male builds a nest in water weeds and guards the young until they can move themselves.

**Special features :** *Amia calva* is the only one living species. *Amia* shows combination of **primitive and advanced** characters. The **primitive characters** include (a) **dorsal, cellular and bilobed lung** (air bladder), (b) **spiral valve vestigial**, (c) **large jugal plate**, well-developed **branchiostegal rays**, and (d) **non-pyloric caeca**. The **advanced** characters include (i) **thin cycloid scales without ganoin**, (ii) **fulcra absent in fin**, (iii) tail **homocercal** and (iv) **vertebrae solid and amphicoelous**. This fish also shows parental care.

**Identification :** Since this fish has continuous dorsal fin, and above features, hence it is *Amia*.

### 32. *Lepidosteus* : Garpike

**Classification :** Upto super-order classification same as in *Amia*.

Order.....Lepidostiformes → Vertebrae solid, opisthocoelous and ganoid scales in oblique rows.

Family.....Lepidosteidae

Genus.....*Lepidosteus*

**Geographical distribution :** Widely distributed in U.S.A. Upper Cretaceous to Recent.

**Habit and habitat :** *Lepidosteus* is found in fresh-water rivers. It is a voracious feeder on small fishes.

Sometimes, it also comes out of the surface to emit bubbles of gases. The heavily armoured predaceous gars usually occur in shallow weedy areas.

**Comments :**

- (1) Commonly known as **garpike**, measures about 2 to 3 metres.
- (2) Body is elongated with short caudal region and is divided into **head, trunk and tail**.
- (3) Body is covered with thick rhombic ganoin-coated and articulated scales, about 50 to 65 along lateral line. Scales articulate with one another by peg-and-socket joints.
- (4) **Head** is produced into snout. Both the upper and lower jaws are elongated to form a sort of gar.
- (5) **Eyes** are developed. **Gills** are covered by **operculum**. **Nostrils** are found at the anterior end of beak.
- (6) **Dorsal fin** with few rays. Dorsal and anal fins are far back near the tail. **Caudal fin** is rounded and **semi-heterocercal**. Paired pectoral and pelvic fins present.
- (7) Vertebrae **opisthocoelous** and solid with convex anterior and concave posterior ends, as in some reptiles and unlike other fishes. Vomer paired.
- (8) Tail symmetrical, spiracles closed.
- (9) **Air bladder** is used as lung. It is vascularized and thus permits aerial respiration.

**Economic importance :** Scales and skin of gars are used in the manufacture of **hand bags and arts**.

**Special features :** *Lepidosteus* shows a number of **primitive features** such as **cellular air bladder**, **ganoin-coated scales**, **presence of fulcra**, **absence of jugal plate** and **closed spiracle**. It also shows

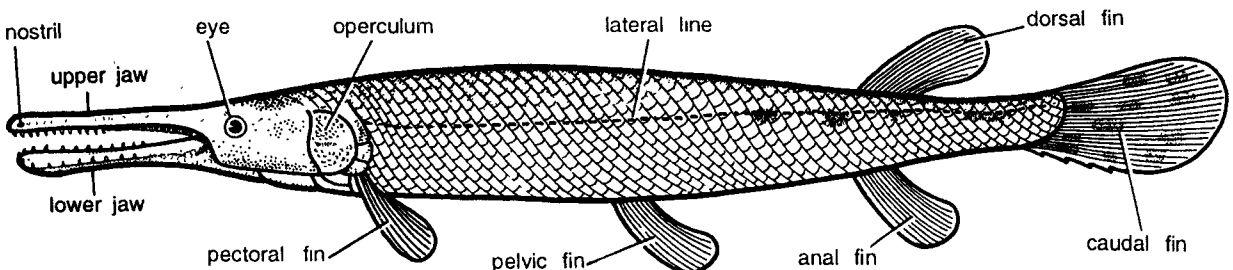

Fig. 32. *Lepidosteus* (Garpike).

teleostian and advanced features such as branched pyloric caeca, reduced maxilla, presence of tooth-bearing infra-orbitals and opisthocelous vertebrae.

**Identification :** Since this fish has toothed jaws, posterior dorsal fin and above features, hence it is *Lepidosteus*.

### 33. *Salmo sola* : Trout

**Classification :** Upto superclass classification same as in *Amia*.

Superorder.....	Teleostei	→	Bony fish proper.
Order.....	Isospondyli	→	Tail homocercal. Fins without spiny rays. Air bladder communicates with pharynx by a duct. Maxillae included in gap of mouth.
Family.....	Salmonidae	→	Gill membranes extending far forward, free from isthmus. Pelvic axillary process present.
Genus.....	<i>Salmo</i>		
Species.....	<i>sola</i>		

**Geographical distribution :** Fresh-water and marine fish. It is found in temperate and Arctic zones of northern hemisphere such as North America—California to Alaska, Europe and Canada. It has been introduced in Kashmir and the Nilgiris. Jurassic to Recent.

**Habit and habitat :** Salmon is found in sea water. They are famous for their beauty, **migratory** habits and colour changes. Young migrate to sea and mature in 2 to 8 years, return to fresh-water, spawn once and die.

#### Comments :

- (1) Commonly known as **trout**, weights 10 to 15 kg.
- (2) Elegant spindle-shaped body is covered with **overlapping scales**. Body is divided into **head, trunk and tail**.
- (3) **Head** is conical in shape and contains **eyes and nostrils**.
- (4) The margins of upper jaw are formed by pre-maxillaries and maxillaries.
- (5) Paired fins are pectoral and pelvic fins.
- (6) **Pectoral fin** is close to operculum. **First dorsal fin** in middle and **second dorsal fin** between first dorsal fin and **caudal fin**. **Anal fin** just below second dorsal fin. Fins without fin rays.
- (7) **Tail homocercal**. **Air bladder** having open duct to pharynx. **Operculum** and **lateral line** distinct.
- (8) Ova shed in abdominal cavity before passing to exterior.

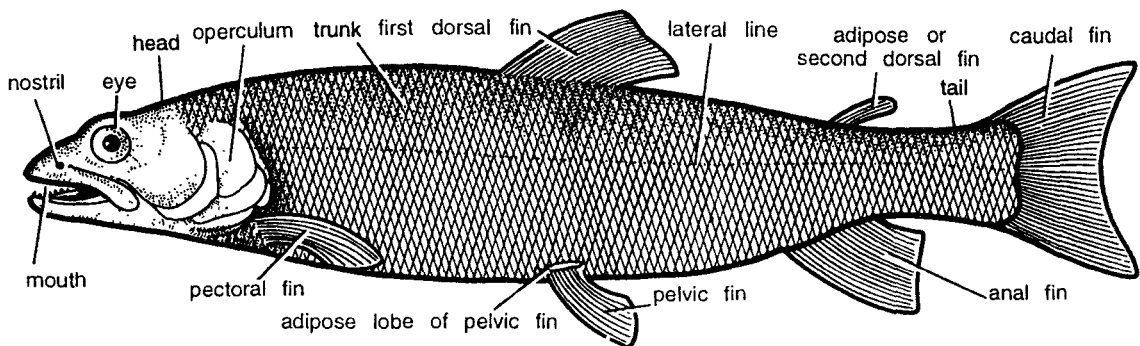

Fig. 33. *Salmo sola*.



**Economic importance :** Salmon and trout possess a small adipose fin on the back. They are much prized for food and game. Millions of pounds are taken in nets, used fresh or canned. Various salmon and trout fishes have been transplanted to new localities.

**Identification :** Since this fish has adipose fin and above features, hence it is *Salmo*.

### 34. *Esox lucius* : Pike

**Classification :** Classification upto superorder same as in *Amia*.

Order..... Haplomi → Fins with soft rays. Pelvic fin abdominal. Air bladder communicates with pharynx.

Family..... Esocidae

Genus..... *Esox*

Species..... *lucius*

**Geographical distribution :** *Esox* is abundantly found in Europe, Northern Asia and U.S.A.-Arkansas and Minnesota eastward and Eurasia. Jurassic to Recent. The fossils are known as early as the Oligocene in Europe.

**Habit and habitat :** *Esox* is a marine fish, carnivorous, predacious and noted for their voracity.

**Comments :**

- (1) Commonly called as **pike**, measures 3 meters in length and weight 45 kgs.
- (2) Body elongated, divided into **head, trunk and tail**. **Head** produced into snout. Head contains eye nostril and mouth.
- (3) **Mouth** large and margin of upper jaw formed by premaxillaries and toothless maxillaries.
- (4) Branchiostegal rays 10 to 20; nasal present; vertebrae 43 to 67.
- (5) Supra-occipital is in contact with the frontals.
- (6) **Opercular bone** is well developed. Infra-orbital canal with eight or more pores.
- (7) Single dorsal fin and anal fins near tail end. Tail contains caudal fin.
- (8) Pectoral fins inserted very low **pelvic fins** between **pectoral** and **anal fins**.

**Special features :** Pyloric caeca absent. These slender bodied fishes are with large mouths and conspicuous teeth. Some forms grow upto 2.5 m and over 50 kg forming choice game fish.

**Identification :** Since this fish has far back dorsal and anal fins and above features, hence it is *Esox*.

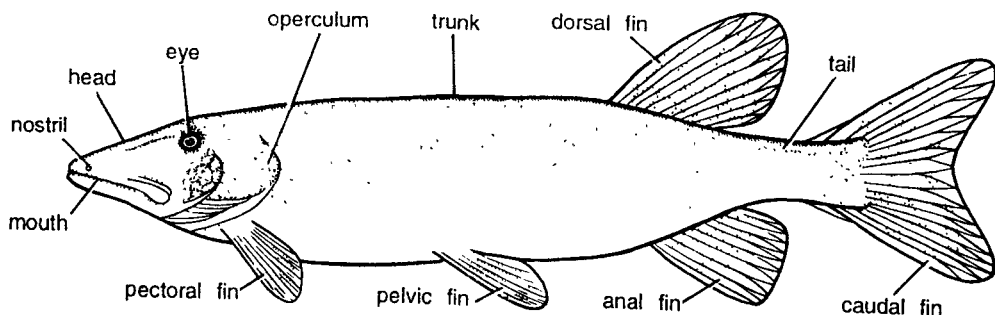

Fig. 34. *Esox lucius*.

### 35. *Notopterus* : Chitala

#### Classification :

Phylum.....	Chordata	→	Dorsal tubular nerve cord, notochord and gill-slits.
Group.....	Craniata	→	Definite head, cranium and brain.
Subphylum.....	Vertebrata	→	Vertebral column present.
Division.....	Gnathostomata	→	Jaws and paired appendages.
Superclass.....	Pisces	→	Paired fins, gills and skin with scales.
Class.....	Osteichthyes	→	Bony fishes.
Sub-class.....	Actinopterygii	→	Ray-finned fishes.
Superorder.....	Teleostei	→	Bony fish proper.
Order.....	Ostariophysi	→	Anterior vertebrae fused. Weberian ossicles present between air bladder and ear.
Family.....	Notopteridae		
Genus.....	<i>Notopterus</i>		

**Geographical distribution :** *Notopterus* is widely distributed in India, Myanmar, Malaya and West Africa.

*N. chitala* is exclusively found in the fresh-waters of India. Eocene to Recent.

**Habit and habitat :** *Notopterus* commonly inhabits marshy meadows, lakes, fresh-water of brackish water.

It is a **bottom feeder, carnivorous, predacious** and feeding on small organisms, insects and crustaceans.

#### Comments :

- (1) Commonly known as **cat-fish** or **Chitala**. Body divided into **head, trunk and tail**.
- (2) Body is very strongly compressed with a short pre-caudal region and measuring about 1.5 meters in length.
- (3) Colour is silvery dark or greenish or glossy yellow on the back.
- (4) **Head** contains large and **oblique mouth**, whitish **eyes** and **nostrils**.
- (5) **Dorsal fin** is short and **ventral fin** very much **reduced** or **absent**. Very much elongated **anal fin** confluent with reduced **caudal fin**. Number of combined rays of **anal** and **caudal fin** varies from 85 to 100.
- (6) **Paired pectorals** and **ventral fins** closely placed.
- (7) **Air bladder** is very large and divided into several compartments.
- (8) **Teeth** are **homodont**.
- (9) **Gill covers** are scaly. **Lateral line** scales 120 to 180, ventral scutes 25 to 45.

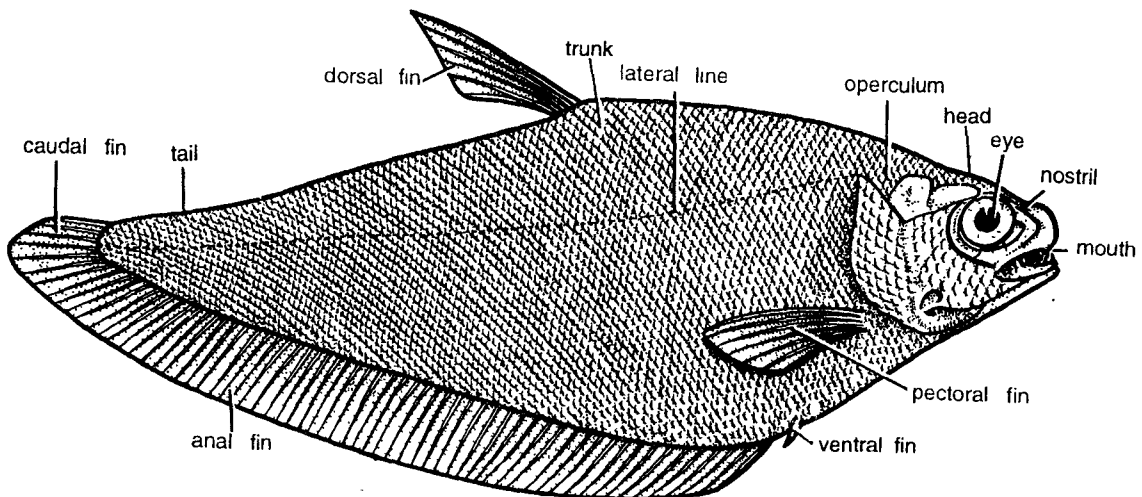

Fig. 35. *Notopterus*.

**Economic importance :** The flesh of the fish is very rich in nutrition and well flavoured.

**Identification :** Since this fish has confluent anal and caudal fins, strongly compressed body and above features, hence it is *Notopterus*.

### 36. *Labeo rohita* : Rohu

**Classification :** Same as in *Notopterus*.

Family..... Cyprinidae

Genus..... *Labeo*

Species..... *rohita*

**Geographical distribution :** *Labeo rohita* is widely distributed in tropical and temperate regions specially found in India (Punjab, Assam) and Myanmar Eocene to Recent.

**Habit and habitat :** *Labeo rohita* is abundantly found in ponds and rivers. Carps are **vegetarian** and **bottom feeders**. They can occasionally feed on animal diet. Because of its feeding habit, it is cultivated with two other carps, *Catla catla* and *Cirrhina mrigala*. Rohu breeds only in the rivers and bund type of tanks but not in confined waters.

**Comments :**

- (1) Commonly known as **carp** and **Rohu** in Hindi.
- (2) **Body** compressed, fusiform, about 1 metre in length and weighing about 4 kg.
- (3) Colour of the body is bluish or brownish on back and silvery white below. Body covered with large overlapping cycloid scales. Scales are of taxonomic importance.
- (4) Body is regionated into **head, trunk** and **tail**.
- (5) **Head** is depressed and is produced into a short, **obtuse** and **blunt snout**. It bears a subterminal fringe-lipped **mouth** bounded by fleshy upper and lower lips. It also contains paired **nostrils** and paired **eyes**.
- (6) A pair of **filamentous barbels** arises from upper lip. Small tubercles cover the snout, which is oblong, depressed, swollen and projecting beyond the jaws.
- (7) **Large operculum** hangs on either side enclosing gills and branchial chamber.
- (8) **Lateral line** is distinct. Scales overlying the lateral line are perforated by tubes of the lateral line system. Scales are of taxonomic value. Scales are flat, bony with rounded edges and are called as cycloid scales. These overlap and form a complete covering.
- (9) **Dorsal, anal, caudal, paired pectoral** and anal fin with soft fin rays present. **Caudal fin** forked into equal lobes.
- (10) **Weberian apparatus** present between bladder and inner ear. Kidneys are mesonephric.

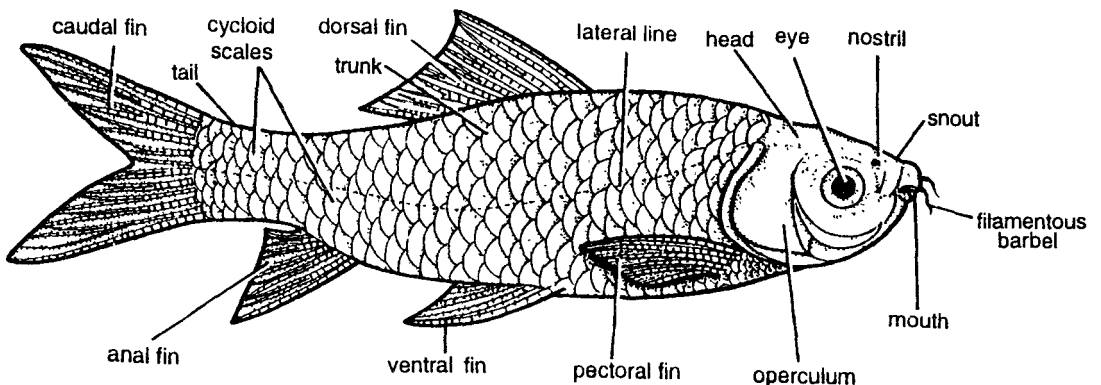

Fig. 36. *Labeo rohita*.

**Economic importance :** *Labeo* has great food value, forming common man's food. The flesh is very delicious.

**Special features :** Mouth does not contain teeth. Teeth are found in pharynx only.

**Identification :** Since this fish has overlapping scales and above features, hence it is *Labeo rohita*.

### 37. *Clarius* : Magur : Mangur

**Classification :** Same as in *Notopterus*.

Family..... Claridae

Genus..... *Clarius*

**Geographical distribution :** *Clarius* is distributed in India, Myanmar, Sri Lanka and Malaya Archipelago. Eocene to Recent.

**Habit and habitat :** *Clarius batrachus* is found in fresh and brackish waters. It takes a wide variety of food including clams, insect larvae and crustaceans living in dirty ponds and muddy water. They act as scavengers.

**Comments :**

- (1) Commonly called as **cat-fish** or **magur**. Body is divided into **head, trunk** and **tail**.
- (2) It is characterized by its spikeless **dorsal fin**, which extends all along the body from **operculum** to **caudal fin**. **Anal fin** also extends from caudal fin to middle of the body. **Pectoral** and ventral fins closely placed.
- (3) **Head** is flat with four pairs of non-contractile and sensory barbels. Head bones are superficially exposed. Head contains reduced eyes and nostrils.
- (4) Body is covered by scaleless and naked skin.
- (5) **Dendritic accessory branchial** apparatus supplements gill respiration and hence fish can live for a very long period outside water.
- (6) **Air bladder** is **physostomous**.
- (7) Spiracles absent. Lateral line distinct.
- (8) Parietals, symplectics and sub-operculum absent.
- (9) **Tail** is laterally compressed, **diphycercal** and having rounded caudal fin.
- (10) **Weberian ossicles** connecting internal ear and air bladder present.

**Economic importance :** Magurs are much valued for food.

**Special features :** Magur supplements gill respiration with **accessory organs of respiration**. It can remain away out of water for long time. It can also travel a distance of 1/2 km on its paired fins and is called as walking fish. On land respiration by accessory respiratory organs.

**Identification :** Since this fish has peculiar dorsal fin, barbels and above features, hence it is *Clarius*.

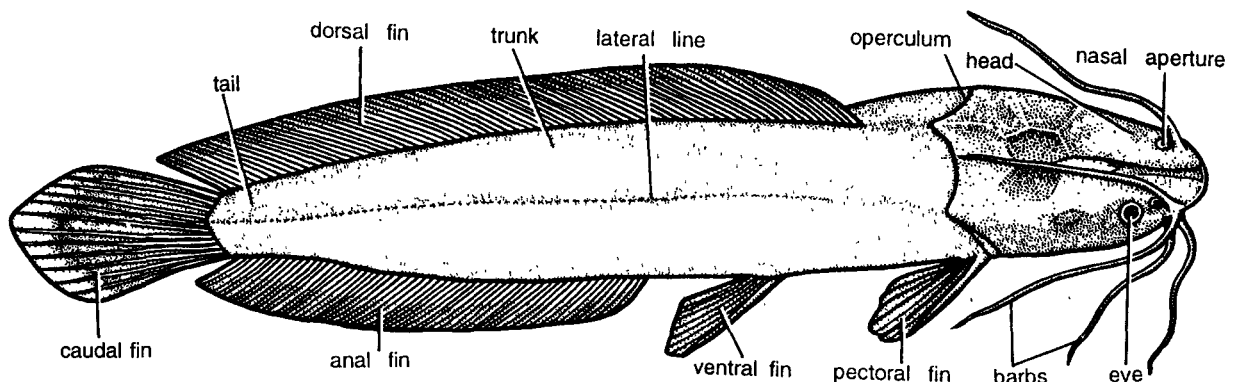
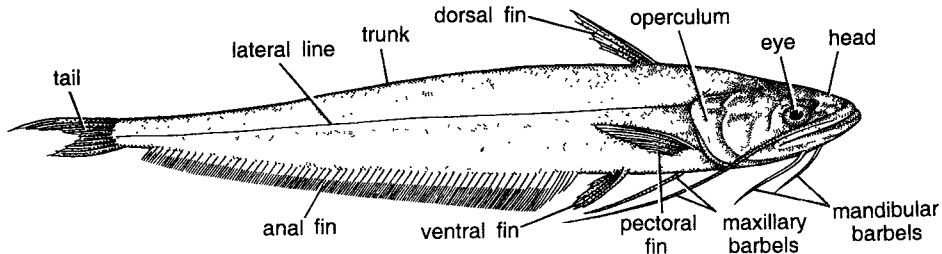

Fig. 37. *Clarius* (Magur).

Fig. 38. *Wallago attu*.

### 38. *Wallago attu* : Lachi

**Classification :** Same as in *Notopterus*.

Genus..... *Wallago*

Species..... *attu*

**Geographical distribution :** *Wallago* is distributed throughout India. Eocene to Recent.

**Habit and habitat :** *Wallago* is found in temperate and tropical fresh-waters, inhabiting deep flowing waters of rivers and tanks in hilly and low country regions. It is **predacious** and feeds on young carps.

**Comments :**

- (1) Commonly called as **cat-fish** or **Lachi**.
- (2) Colour of the body varies. Dorsally it is greyish brown, head is purplish and belly whitish.
- (3) Body is divided into **head**, **trunk** and **tail**. **Head** is very large, trunk small and tail long and tapering. Jaws provided with villiform teeth.
- (4) Clefts of the mouth extend behind the orbits.
- (5) Head contains **nostrils**, 2 long **maxillary** and 2 smaller **mandibular sensory barbels**.
- (6) **Eyes** are found above the level of the mouth and not covered with skin.
- (7) **Weberian ossicles** are present. Gill membranes free.
- (8) **Dorsal fin** is small like **pectorals**. It has fewer than seven rays and is not preceded by a spine. Adipose fin absent. **Pectoral fin finely serrated**. **Anal fin large** and extends upto caudal fin but not confluent with caudal fin. **Caudal fin forked**. Anal fin very much elongated and contains about 90 anal rays. **Ventral fins** small.
- (9) **Scales** are **absent** and body is covered with naked skin. Profile of the back oblique.

**Identification :** Since this fish has smooth skin, small dorsal fin and above features, hence it is *Wallago*.

### 39. *Barbus sarana* : Minnow

**Classification :** Same as in *Notopterus*.

Family..... Cyprininae → Jaws toothless. Teeth in pharynx.

Genus..... *Barbus*

Species..... *sarana*

**Geographical distribution :** *Barbus* is distributed in Myanmar and India. Eocene to Recent.

**Habit and habitat :** *Barbus* is a common fresh-water fish of ponds, lakes and rivers.

**Comments :**

- (1) Commonly called as **Minnow** or **carp**.
- (2) Body of the fish is covered with large scales and is divided into **head**, **trunk** and **tail**.
- (3) **Head** has an upward mouth without inner fold, **small barbels**, large **eyes** without adipose eye lid and devoid of scales. Head contains nostril.

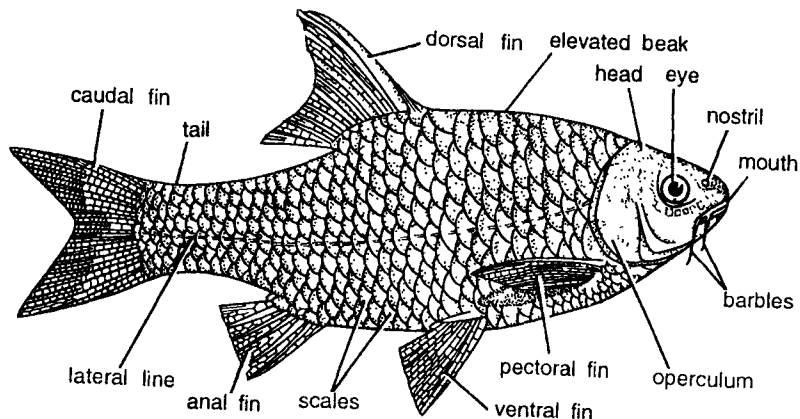

Fig. 39. *Barbus sarana*.

- (4) **Lips** thin without plicae or **papillae**; upper jaw bordered only by premaxillae.
- (5) Pharyngeal teeth in one to three rows, never more than eight teeth in any one row.
- (6) Profile of the back is elevated. Inter-orbital space convex. **Operculum** and **lateral line** present.
- (7) **Fins** are whitish or yellowish. **Dorsal fin** is opposite to **anal fin** and contains spine-like rays. Caudal fin forked. Pectoral and ventral fins present.
- (8) **Operculum** is stout with golden colour.
- (9) **Air bladder** divided into right and left lobes by a constriction and enclosed in an osseous capsule.

**Economic importance** : The fish is used as food.

**Identification** : Since this fish has scaleless head, simple lips and above features, hence it is *Barbus*.

#### 40. *Ophiocephalus punctatus* : Snake Head

**Classification** : Upto superorder same as in *Notopterus*.

Order..... *Ophiocephaliformes* → Teeth present on jaws and palate.

Genus..... *Ophiocephalus*

Species..... *punctatus*

**Geographical distribution** : It is distributed in India, Tropical Africa and Southern Asia.

**Habit and habitat** : Commonly found in fresh-water ponds and rarely in flowing waters. They are able to survive drought in semifluid or beneath dry mud and have an accessory branchial cavity for aerial breathing.

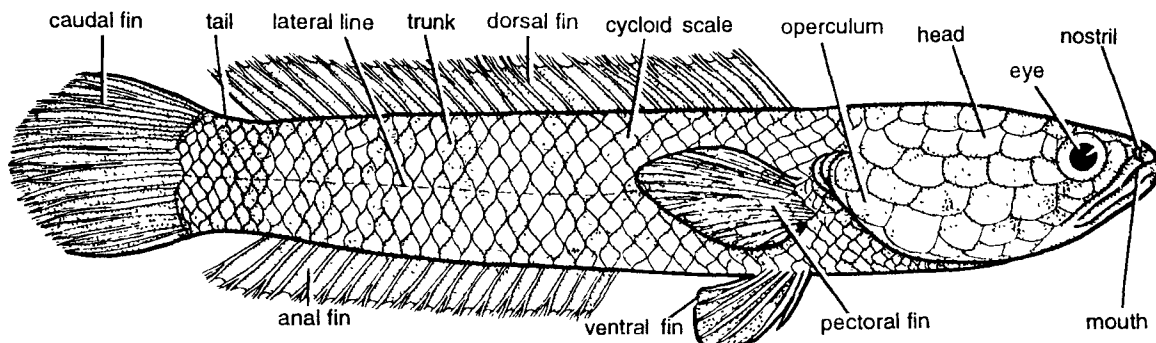

Fig. 40. *Ophiocephalus punctatus*.

**Comments :**

- (1) Commonly referred to as **snake-headed fish**. Colour of the fish varies with water, with greenish back, yellowish sides and striped abdomen. Some specimens possess scattered dots on the head.
- (2) Body is elongated and cylindrical and differentiated into **head, trunk and tail**. Head and body covered with cycloid scales. Head contains **nostril, mouth and eyes**.
- (3) **Head** triangular, tapers into a pointed snout. Teeth present on jaws and palate. Maxillae excluded from border of upper jaw. Lower jaw protruding beyond upper jaw.
- (4) Suprabranchial organ present for breathing.
- (5) **Dorsal and anal fins** are long. **Pectoral fins** nearer to **ventral fin**. Dorsal fin extends from near operculum upto near caudal fin. Anal fin originates from middle of the body and extending upto near caudal fin.
- (6) **Caudal fin** is rounded and fan-shaped.
- (7) **Lateral line** is slightly curved. **Air bladder** long.

**Economic importance :** *Ophiocephalus* is eaten as food. Its raw flesh is used to **cure ulcers**.

**Special features :** It can breathe atmospheric air due to the presence of a supra-branchial cavity. The fish acts as host for camallanid nematodes.

**Identification :** Since this fish has characteristic anal and dorsal fin and above features, hence it is *Ophiocephalus*.

### 41. *Anguilla vulgaris* : Eel

**Classification :** Same as in *Notopterus*.

Order..... Apodes or → Body long and slender. Air bladder with ducts. Gill openings small. Scales minute or absent. Dorsal, caudal and anal fins continuous.

Anguilliformes

Genus..... *Anguilla*

Species..... *vulgaris*

**Geographical distribution :** *Anguilla vulgaris* is widely distributed in Europe, North Africa, temperate Asia, North America, Mexico, West Indies, Australia and New Zealand. They are not found in Eastern Pacific and South Atlantic. Cretaceous to Recent.

**Habit and habitat :** *Anguilla* is a fresh-water fish. It is a voracious feeder and **catadromous fish** and it can live for several hours out of water. The adult eels live in ponds, estuaries, rivers and coastal areas of the sea and damp grass or moss outside water.

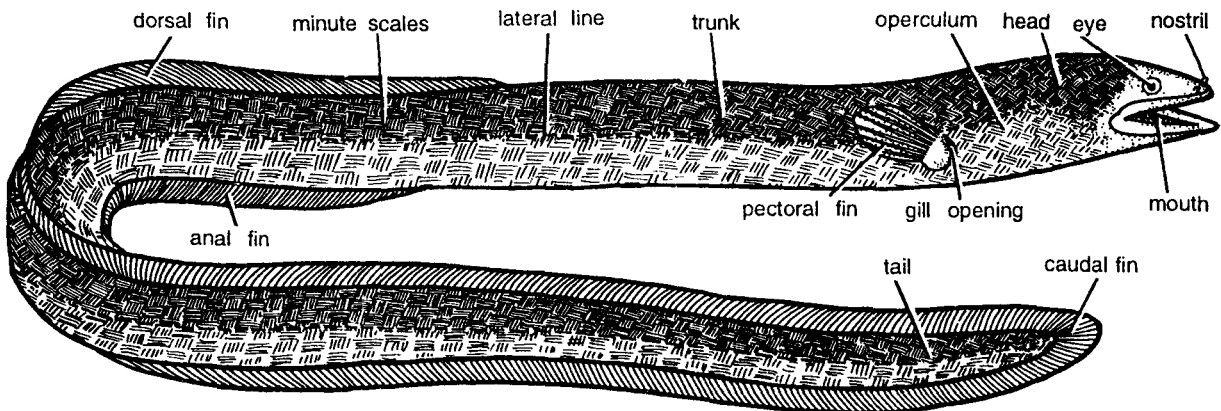

Fig. 41. *Anguilla vulgaris*.

**Comments :**

- (1) Commonly known as **eel**, measuring 1.2 metres in length.
- (2) **Body** is slender, elongated and snake like. Body divisible into **head, trunk and tail**.
- (3) On each side operculum covers the **gill slits**. Head contains **mouth, eyes and nostril**.
- (4) **Dorsal fin, anal fin and caudal fin** are joined together forming a **continuous fin**. **Fins** are supported by **fin rays**.
- (5) Body is covered by minute scales embedded in the skin and arranged obliquely at right angles to one another forming a curious pattern.
- (6) Maxillaries and palatopterygoid present, gill cleft separate and vertebrae greatly enlarged.
- (7) Spines absent, gill openings small, air bladder has a **ductus pneumaticus**. Oviducts absent.
- (8) **Gills** displaced posteriorly with 6 to 22 branchiostegal rays. There are no special accessory organs for breathing air. When on land, probably air is taken through skin.

**Special features :** Eels have peculiar breeding habits and life-histories. Both the American and European eels, when about 60 cm long, put on breeding colours. The green European eel travels about 3,000 miles to spawn in hot waters of West Indies. Upon reaching the coastal waters, green colour changes to silver eyes are enlarged and gonads mature. The fish lays about 10 million eggs, which hatch into pelagic larvae called as **Leptocephali**. These larvae take homeward journey. On the contrary to present known work, Aristotle thought that they come from '**entrails of earth**'.

**Identification :** Since this fish has continuous caudal, anal and dorsal fins and above features, hence it is **Anguilla**.

### 42. *Amphipnous cuchia* : Eel

**Classification :** Same as in *Notopterus*.

Order..... Synbranchiformes

Genus..... *Amphipnous*

Species..... *cuchia*

**Geographical distribution :** *Amphipnous* is distributed in India, Myanmar, Africa, Indo-Australian Archipelago, Central and South America.

**Habit and habitat :** *Amphipnous* is found in fresh and brackish water. It is an **amphibious fish**. It frequently rises to the surface for the purpose of respiration and is often found lying like a snake in the grassy sides of ponds.

**Comments :**

- (1) Commonly called as Eel-like fish.
- (2) Fish is long snake-like, about 1 metre in length. Body divided into **head, trunk and tail**.

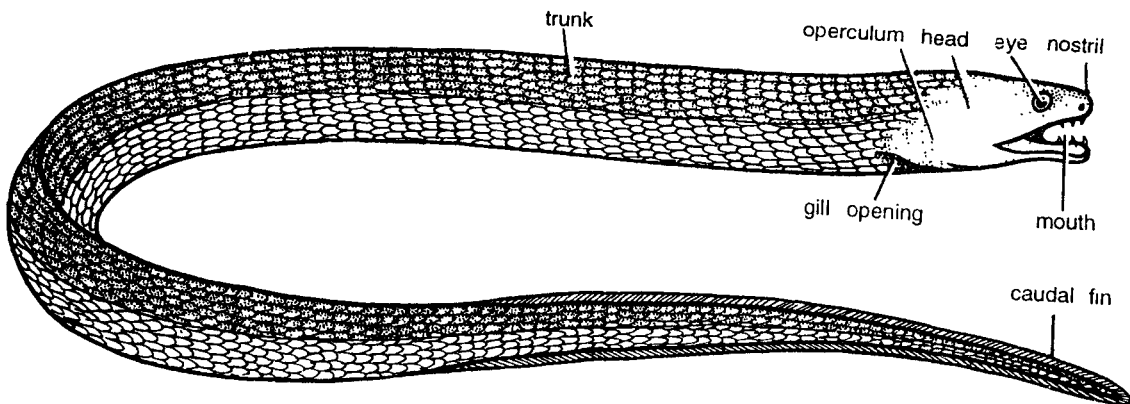

Fig. 42. *Amphipnous cuchia*.



- (3) Colour of the body is **brownish** with numerous **black spots**.
- (4) Body is slimy and covered with minute scales.
- (5) **Paired and median fins** absent, **caudal fin** is reduced, and a membranous flap without rays is present around **tail**.
- (6) **Head** contains **small eyes**. **Nostril** valve opens above orbit.
- (7) Stomach caecum absent and anus far behind from the head.
- (8) **Gill** openings covered by operculum are confluent into one slit on the ventral surface.
- (9) Chief respiratory organs consist of two separate **lung-like air sacs** connected with gill cavity.

**Special features :** *Amphipnous* has a **respiratory air sac** on each side of the neck behind the head and continuous with the gill cavity. It has only one species, *Amphipnous cuchia*.

**Identification :** Since this fish has minute scales and snake like body, hence it is *Amphipnous*.

### 43. *Pterois* : Scorpion Fish

**Classification :** Same as in *Notopterus*.

**Order.....** Scorpaeniformes → Sub-orbital extends across the cheek to the pre-operculum.

**Genus.....** *Pterois* (Scorpion fish).

**Geographical distribution :** *Pterois* is widely distributed in all tropical and temperate seas. Cretaceous to Recent.

**Habit and habitat :** *Pterois* is a marine, viviparous, **carnivorous, sluggish fish**. It easily adopts the surrounding colour. Sometimes the skinny appendages resemble the fronds of seaweeds.

**Comments :**

- (1) Commonly called as **scorpion fish** or 'mail-checked' fish.
- (2) Body oblong, more or less compressed, elongated, covered with scales and divided into **head, trunk and tail**.
- (3) **Head** is spiny, containing large **eyes, nostrils, mouth** and is provided with membranous processes and **spines**.
- (4) **Dorsal fin** contains 11 to 17 spines and 8 to 18 soft rays, ventral fin 1 spine and 2 to 8 soft rays, **anal fin** 1 to 3 spines and 2 to 5 soft rays, and well-developed **pectoral fin** has 15 to 25 rays.
- (5) **Air bladder physoclistic** and gills **pseudobranchiate**.
- (6) **Spiracles** absent.
- (7) Skeleton is ossified.

**Special features :** *Pterois* is **dangerous**.

If attacked, using its sharp, grooved and dorsal spines like hypodermic needles, it injects stinging and paralyzing venom. **Spines inflict serious and painful wounds**. Dorsal, anal and pelvic spines contain venom glands.

**Identification :** Since this fish has spiny dorsal fin and above features, hence it is *Pterois*.

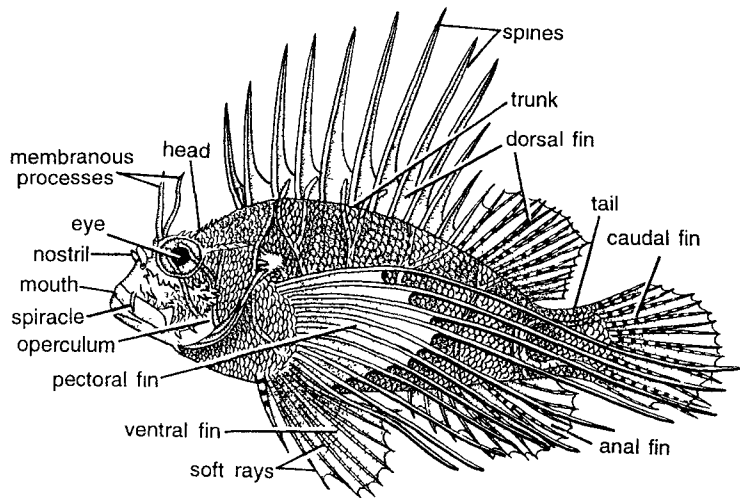

Fig. 43. *Pterois*.

## 44. *Anabas* : Climbing Perch

**Classification :** Same as in *Notopterus*.

**Order.....** Percomorphi → Perches. Dorsal and anal fins with spiny and soft fin rays. Pectoral arch attached to skull by forked post-temporal.

**Family.....** Anabantidae

**Genus.....** *Anabas* (Climbing perch)

**Geographical distribution :** *Anabas* is distributed in Myanmar, India, Africa, Philippines, Sri Lanka and Malayasia Archipelago. Upper Cretaceous to Recent.

**Habit and habitat :** *Anabas* is a common South Indian fresh-water fish. It can live out of water for a long period. It is predator on shrimps, ostracods, gastropod shells and young fishes. Male exhibits parental care.

**Comments :**

- (1) Commonly known as **climbing perch**.
- (2) Fish measuring about 30 cm is olive green in colour.
- (3) Body of the fish covered by cycloid scales and divided into **head, trunk and tail**.
- (4) **Head** is conical containing large **eyes, nostrils** and **mouth**. Jaws, prevomer and parasphenoid with fixed conical teeth.
- (5) In front of eyes is a pre-orbital bone containing spines. Small spines also occur along the edge of operculum.
- (6) **Dorsal fin** consists anterior dorsal fin and posterior dorsal fin. Similary **anal fin** divided into anterior anal fin and posterior anal fin. **Caudal fin** is fan shaped.
- (7) Ventral are anteriorly situated almost below **pectorals**.
- (8) **Accessory respiratory** super-branchial organ is well developed, having thin and folded bony laminae covered with mucous membrane. Air bladder physoclistous.
- (9) Tail is perfectly **symmetrical**.

**Special features :** *Anabas* is able to walk on land by spines in search of earthworms. The crows and kites attack them and take their bodies over trees, and thus the fish is called as **climbing perch**, as the fish might have climbed trees. But the fish cannot climb the tree. *Anabas* is so much dependent on atmospheric oxygen that it is **asphyxiated** if kept in water with no access to air. Fish can live out of water for a long period.

**Identification :** Since this fish has dorsal and anal fins rays and above features, hence it is *Anabas*.

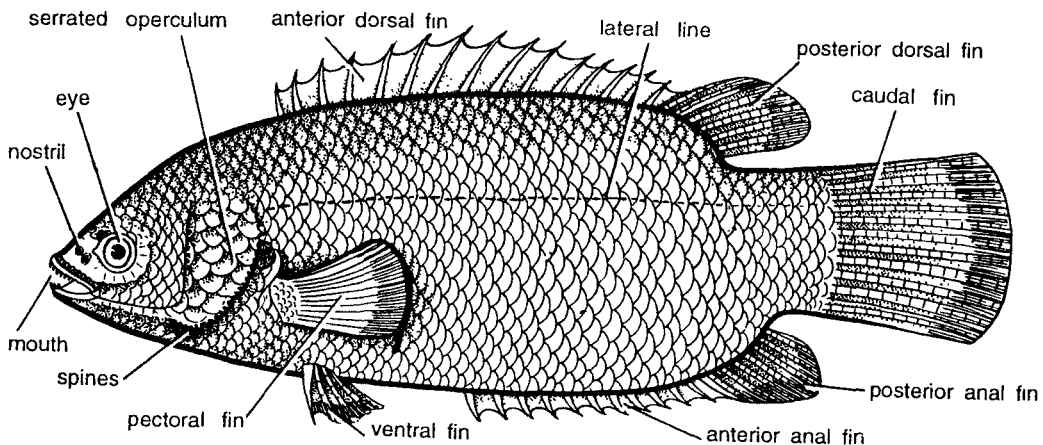

Fig. 44. *Anabas*.

## 45. *Exocoetus* : Flying Fish

**Classification :** Same as in *Notopterus*.

Order..... *Synentognathi* → Flying fish, Dorsal fin above anal. Pectorals high on body. ,

Genus..... *Exocoetus*

**Geographical distribution :** Distributed in tropical and warmer Atlantic, Pacific and Indian oceans.

**Habit and habitat :** *Exocoetus* is found in sea, often skittering near the boats. It is **pelagic** and feeding on prawns and young fishes and their eggs. Small fishes live in sandy shoal-places near the coast.

**Comments :**

- (1) Commonly known as **flying fish**.
- (2) Elongated body with silvery white sides measures 30 to 45 cm in length and divided into **head, trunk and tail**.
- (3) Body covered with overlapping cycloid scales (usually 38 to 60 in lateral line).
- (4) Head contains large **eyes**. The upper part of **snout** is produced into a process and contains nostril.
- (5) **Mouth** opening is small but teeth in both jaws.
- (6) Lower pharyngeals unite as a single bone. **Lateral line** and **operculum** present.
- (7) **Dorsal** and **anal fins** are short and supported by 8 to 16 soft fin-rays each and are opposite to each pelvic fin.
- (8) **Pectoral fins** are exceptionally large, **spread like wings** and make **gliding flights**.
- (9) Ventral fin well developed and adapted to life the body. The caudal is bilobed. Lower lobe larger than upper lobe. By powerful stroke of the caudal fin the fish is able to leave water with force.
- (10) **Tail is hypoblastic. Oviparous.**

**Economic importance :** The flying fish also serves as food.

**Special features :** *Exocoetus* is not a true flying fish. Specially in warm seas, it emerges to glide over the water. Pectorals act as wings. It also leaves water to escape from larger fishes, such as Tunas and Mackerels. The fish can glide over the surface of the water for about 400 metres.

**Identification :** Since this fish has large pectoral fins and above features, hence it is *Exocoetus*.

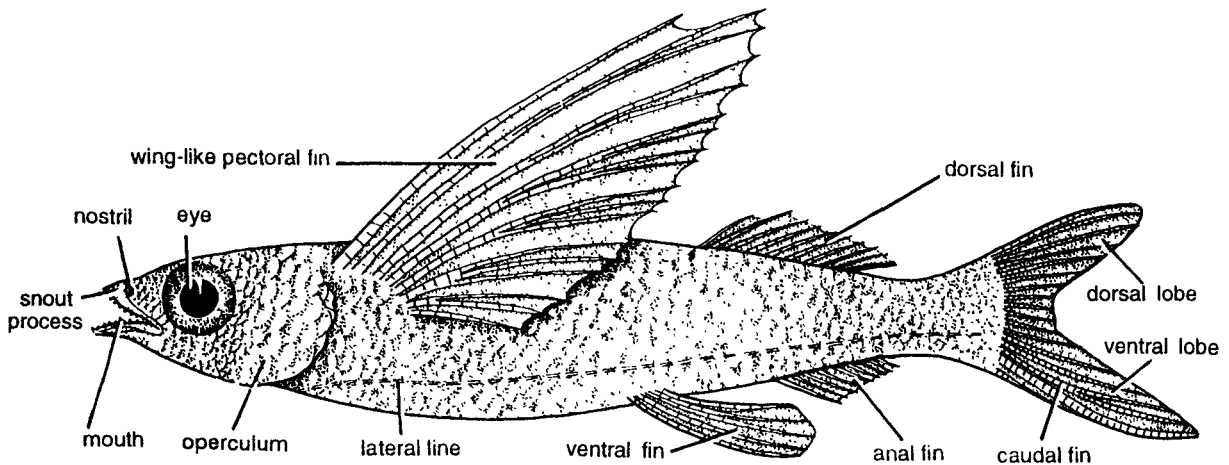
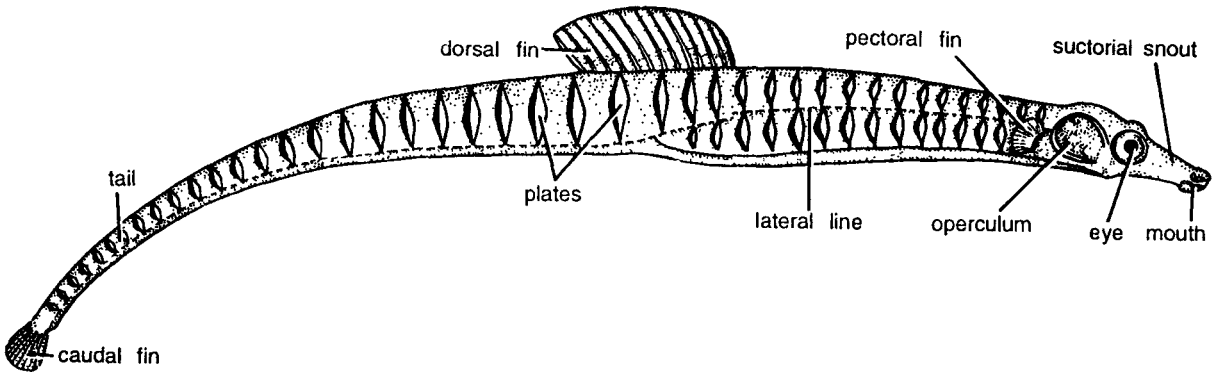

Fig. 45. *Exocoetus*.

Fig. 46. *Syngnathus*.

### 46. *Syngnathus* : Pipe Fish

**Classification :** Same as in *Notopterus*.

**Order**..... Solenichthyes → Pipe-fish and sea horses. Mouth at the end of a tubular snout. Male with brood pouch. Fins minute.

**Family**..... Syngnathidae → Snout tubular and suctorial.

**Genus**..... *Syngnathus*

**Geographical distribution :** *Syngnathus* is distributed in Atlantic, India and Pacific Oceans.

**Habit and habitat :** *Syngnathus* is marine, found in brackish water and some in fresh water.

**Comments :**

- (1) Commonly known as **pipe-fish**.
- (2) Compressed and elongated fish covered by ring-like exoskeletal bands is divided into **head, trunk and tail**.
- (3) Anteriorly half of the head is produced into a suctorial snout having **mouth and eyes**.
- (4) **Gills** reduced. Gill openings very small, near the upper posterior angle of gill cover.
- (5) **Dorsal fin** is present having 16 to 20 rays.
- (6) Tail is long and not **prehensile**, with a small rounded caudal fin.
- (7) Fish swims in **vertical position**.
- (8) **Oviparous**. Fertilization is **external**.
- (9) Males are provided with **brood pouch** on the ventral side of the abdomen formed by the fold of skin.

**Special features :** *Syngnathus* shows parental care. The young ones develop in the brood pouch till they hatch.

**Identification :** Since this fish has elongated body and above features, hence it is *Syngnathus*.

### 47. *Hippocampus* : Sea Horse

**Classification :** Same as in *Syngnathus*.

**Genus**..... *Hippocampus*

**Geographical distribution :** *Hippocampus* has cosmopolitan distribution, found in almost all warm sea waters, specially in India, Japan, China and Malaysian Archipelago. Cretaceous to Recent. It is represented by several species in the Indian Ocean.

**Habit and habitat :** They **swim upright** swaying their tails and gyrating their trunks in graceful manner, holding a weed with their tails.

**Comments :**

- (1) Commonly called as **sea-horse** because its anterior end is shaped like the neck and head of a horse.
- (2) Body is divided into **head, trunk and tail**. Size varies from 5 to 17 cm.
- (3) Head is produced anteriorly into tubular **snout** and backwardly into a **crest**. **Mouth** is found at the end of snout. **Eyes** are situated on the upper side of head. There are two **super orbital spines** backwards directed and outwards.
- (4) Some species have fine trailing filaments over the body.
- (5) Body is covered by a rigid exoskeletal armour of **ring-like bony plates**.
- (6) **Gill clefts** are reduced to a small opening. Gills are of special type in the form of special tufts and covered by **operculum**.
- (7) **Dorsal fin** is single, **ventral** and **caudal** fins are absent.
- (8) A small transparent **pectoral fin** is found on either side of head.
- (9) Females have a small **anal fin**. Males contain **brood pouches**, which carry eggs until they hatch.
- (10) Tail is **prehensile**.

**Special features :** *Hippocampus* is a **vertically swimming fish**. It has strongly deviated from fish-like appearance with **arching neck** and **snout** like horse, abdomen like pigeon and prehensile tail like Langur monkey. Sea horse is a very amusing and most familiar fish. **It swims vertically with its majestic snout.**

**Identification :** Since this fish has horse-shaped head and snout and above features, hence it is *Hippocampus*.

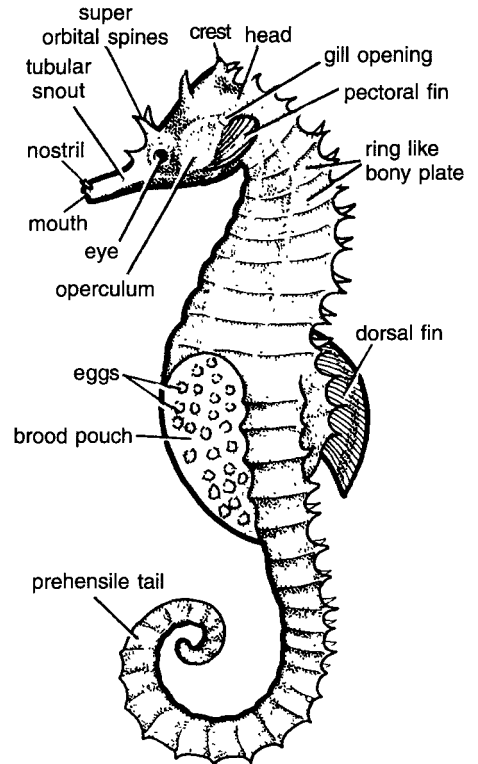

Fig. 47. *Hippocampus* (Male).

## 48. *Echeneis* : Sucker Fish

**Classification :** Same as in *Notopterus*.

**Order**..... *Discocephali* → Dorsal fin modified into an adhesive disk. Other fins normal.

**Family**..... *Echeneididae* → Upper surface of head flat with adhesive disk.

**Genus**..... *Echeneis*

**Geographical distribution :** The fish (*Echeneis*) is distributed all over the tropical and warm seas but specially found on the south coast of England, India, Atlantic and Pacific seas.

**Habit and habitat :** *Echeneis* is a common marine fish. It swims in water feeding on small fishes. It attaches itself by means of its adhesive disk to boats, sharks, bony fishes, sea turtles and marine mammals.

**Comments :**

- (1) Commonly called as **sucker-fish**. Sucking disk is found on head. The disk develops from a transformed spinous **dorsal fin**, the spines of which are split to form 10 to 28 transverse movable lamellae inside a fleshy margin. Fish applies the disk against other fish and creates a partial vacuum by operating the sucking action which permits it to obtain rides on larger animals.
- (2) Body is elongated measuring about 1 metre in length and covered with small scales. **Pectoral fin** inserted high up. Body divided into **head, trunk and tail**.

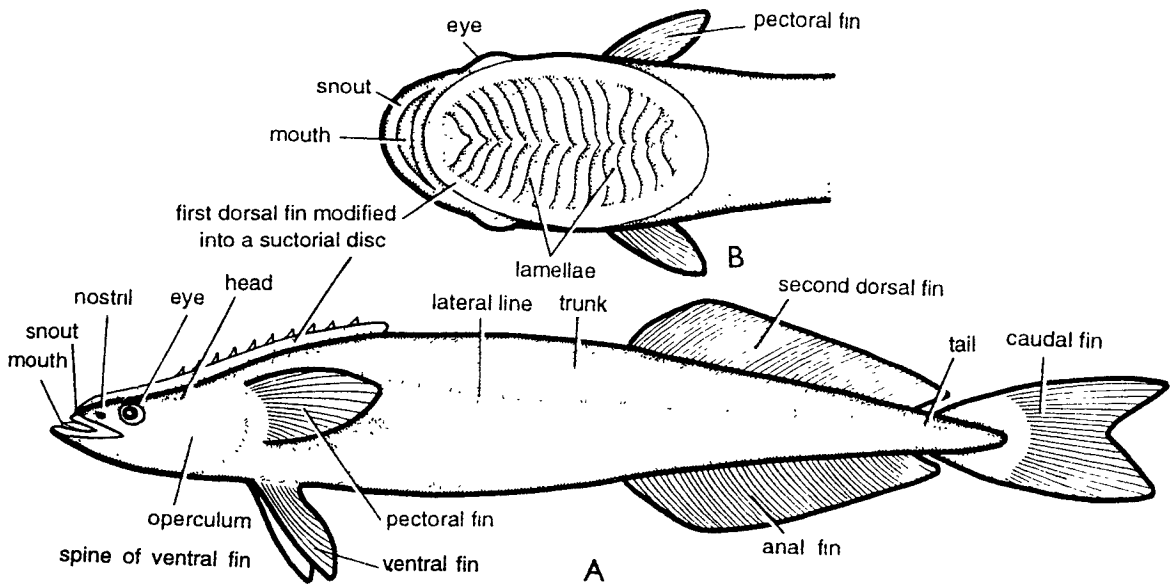

Fig. 48. *Echeneis*. A. Head in dorsal view, B. Fish in lateral view.

- (3) **Head** is depressed and produced into **snout**. **Eyes** are lateral in position. **Mouth** cleft is wide and deep. Nostril near eye present.
- (4) **Second dorsal** and **anal fins** are elongated, opposed to each other and without spines. **Ventral** fin is with one spine and 5 rays.
- (5) **Caudal fin** bilobed.
- (6) **Tail** homocercal.

**Special features** : The sucker-fishes are employed to catch turtles on the east coast of Africa by the natives. It is a lazy fish usually remains attached to sharks, turtles and ships. The attachment is quite firm and not easy to detach. The fish shows commensalism. For instance, *Echeneis remora* attaches the sharks by its modified sucker-like dorsal fin. It feeds on leftovers of the shark. Neither it harms nor benefits the shark.

**Identification** : Since this fish has modified dorsal fin as sucker and above features, hence it is *Echeneis*.

## 49. *Pleuronectes* : Flat Fish

**Classification** : Same as in *Notopterus*.

Order..... *Pleuronectiformes* → Flat-fish.

Family..... *Pleuronectidae*

Genus..... *Pleuronectes*

**Geographical distribution** : *Pleuronectes* is found in South America, India, Malayasia and Southern Hemisphere. Upper Eocene to Recent.

**Habit and habitat** : *Pleuronectes* is a marine bottom dweller in coastal waters lying on side. It feeds on molluscs. It swims by undulating movements. Indian water flat-fish is characterized by banded colouration.

**Comments** :

- (1) Commonly called as **flat-fish**. Body divided into **head**, **trunk** and **tail**.
- (2) Fish is strongly compressed and **asymmetrically flattened**. Head is asymmetrical, the posterior cranium is normal but anterior cranium is twisted with two orbits on one side in the adult and hence the fish

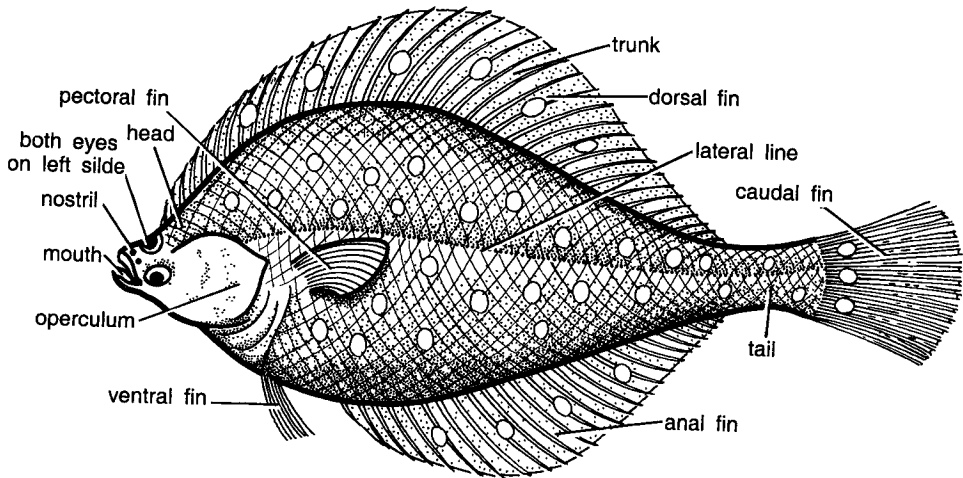

Fig. 49. *Pleuronectes*.

is **sinistral**. Eyes are found on left side. In some cases eyes can be dextral *i.e.*, lying on right side. Nostrils also on left side.

- (3) Body scales are **imbricate**. Cycloid or ctenoid.
- (4) **Mouth** is narrow and protractile. It has sharp chisel-like teeth on the jaws and flattened crushing teeth in the pharynx.
- (5) Right side is white, left side is pigmented while lower side is silvery white.
- (6) The **dorsal** and **anal fins** are elongated, expanded and continue upto beginning of **tail**. Dorsal and anal fins supported by fin rays. **Pectoral** fins are placed high up and ventral fin below pectoral fin. **Caudal fin** fan shaped.
- (7) **Air Bladder** is **physoclistous**. **Lateral line** and **operculum** present spiracle absent.

**Economic importance** : The flat-fish is also an important **food fish** and is sought commercially to a great extent.

**Special features** : Young *Pleuronectes* is bilaterally symmetrical, but adult fish is asymmetrical. It lies on one side and lower eye migrates around so that both eyes are on upper surface.

**Identification** : Since this fish has flat body, both eyes on left and above features, hence it is *Pleuronectes*.

## 50. *Lophius* : Angler Fish

**Classification** : Same as in *Notopterus*.

**Order**..... **Pediculati** → Dorsal fin consists of flexible rays with dilated tips.

**Family**..... **Phiidae**

**Genus**..... ***Lophius***

**Geographical distribution** : *Lophius* is found in the Atlantic, Indian and Pacific Oceans. It also occurs on the coasts of Europe and North America.

**Habit and habitat** : *Lophius* is a marine sea-shore fish found upto 60 fathoms. It captures fish, marine invertebrates and birds. Deep sea Anglers are found up to the depth of 1,500 to 6,000 feet. They are bad swimmers. Those found near the coasts lurk in the mud or sand or among stones or sea-weed. Some pelagic forms attach themselves to floating sea-weed.

**Comments** :

- (1) Commonly known as **Angler-fish**, or **monk-fish**, **toad-fish** or **sea-devil**.
- (2) Body is depressed, dorso-ventrally flattened, ugly, soft and measuring about 4 feet in length. **Head** and anterior part of the body are very large and without scales. Body divided into **head**, **trunk** and **tail**.

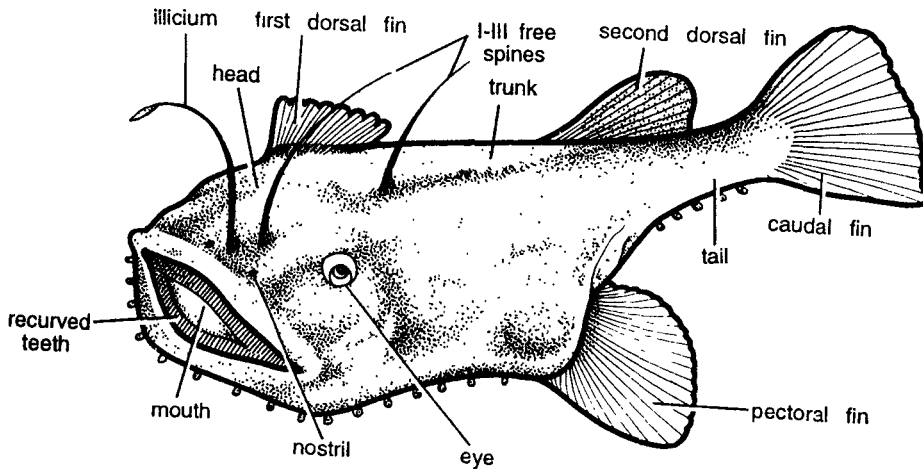
Fig. 50. *Lophius*.

- (3) **Mouth** is wide, containing strong **cordiform** or recurved teeth.
- (4) **Eyes** are large and lateral in position. **Nostril** small.
- (5) **First dorsal fin** greatly modified. Its first **three spines** are not united by fold of skin and the first spine becomes rod-like and bears a fleshy mass or bait at its tip called **illicium**. It is used to attract other fishes and small worms. When any curious and hungry animal comes near bait, it is ferociously attacked and eaten by Angler fish.
- (6) Rest of the first dorsal fin and second dorsal fin supported by fin-rays.
- (7) **Pectoral** and **caudal** fins present.
- (8) Male is small in size and attached to the body of the female as ecto-parasite.

**Special features :** *Lophius* is a deep-sea fish with modified dorsal fin as **bait**. Some of them contain **luminous bulbs** i.e., they are **bioluminescent**. The minute male attaches permanently to the female. Their bodies and blood streams growing together and **such parasitism** is probably an adaptation to ensure mating in the dark depths of the sea.

**Identification :** Since this fish has wide mouth and modified bait-like dorsal fin and above features, hence it is *Lophius*.

## 51. *Tetradon* : Globe Fish

**Classification :** Same as in *Notopterus*.

**Order**..... **Plectognathi** → Body globose, jaws short. Teeth strong incisors. Scales bony or spiny. Gill clefts small.

**Family**..... **Tetradontidae**

**Genus**..... ***Tetradon***

**Geographical distribution :** *Tetradon* is marine (several entering and occurring in brackish and fresh water). Tropical and sub-tropical, Atlantic and Indian Sea.

**Habit and habitat :** *Tetradon* is a marine fish.

**Comments :**

- (1) Commonly called as **globe-fish** or **puffers**. Body divided into **head, trunk** and **tail**.
- (2) Body is light brown along the **back** and **dark brown bands** are found from the back upto the sides. From snout to dorsal fin, **oval light spots** are found in large numbers.



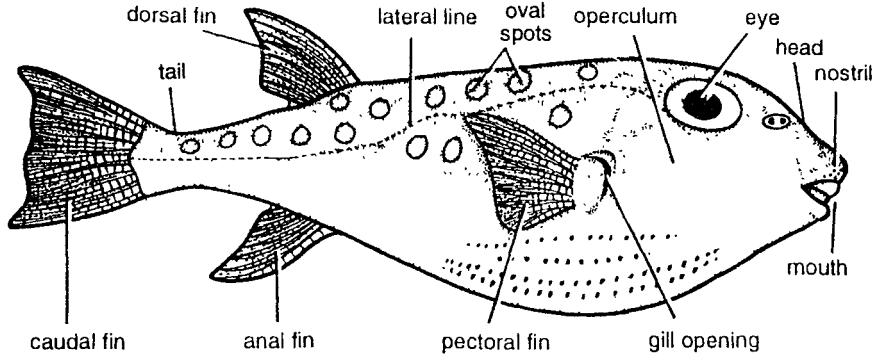

Fig. 51. *Tetradon*.

- (3) **Head** and anterior part of body very large and without scales. Head contains large rounded **eye**, **nostril** and **mouth**.
- (4) Body is rounded and can adapt according to need; it may be flattened or balloon-like.
- (5) Pre-maxillaries are united to maxillaries. Teeth in each jaw are fused to form a beak but are separated by sutures.
- (6) There is one nasal opening on either side, found on a papilla. Eyes are large.
- (7) Dorsal fin opposite to anal fin. Gill opening present near the pectoral. Operculum is present just done the gill opening.
- (8) Lateral line present.
- (9) Body is covered with small spiny, sub-imbricate bony laminae.

**Economic importance :** In Japan dried skin is used in making lanterns. Sometimes doctors prescribe this fish in certain lung infections.

**Special features :** They are also called as 'sea horse' by the natives of Malabar, on account of noise they make when captured. The puffer fish is commonly called as **Fugu** in Japan and is said to contain a powerful alkaloid poison called as **tetradotoxin**, in liver, ovaries and viscera and eating this fish may be fatal.

**Identification :** Since this fish has bony sub-imbricate laminae and above features hence, it is *Tetradon*.

## 52. *Diodon* : Porcupine Fish

**Classification :** Same as in *Tetradon*.

Family.....Diodontidae

Genus.....*Diodon*

**Geographical distribution :** *Diodon* is confined to tropical seas.

**Comments :**

- (1) Commonly known as **Porcupine fish**.
- (2) Body is rounded, **globose** and covered with numerous flexible spines, the organs of defence; they are erected to protect from enemy. Some forms inflate their bodies by swallowing water. Scales generally spiny or bony.
- (3) Body divided into **head**, **trunk** and **tail**. Head contains **mouth**, **nostril** and large rounded eyes.
- (4) Inter-operculum is rod like and attached to the anterior limb of sub-operculum.
- (5) **Paired pectoral fin** near **operculum**. Dorsal fin near **caudal fin**. **Caudal fin** is rounded and tilted upwards **anal fin** opposite to dorsal fin.
- (6) **Gills** are three in number. Belly inflatable. Gill opening distinct.
- (7) **Skin leathery**.

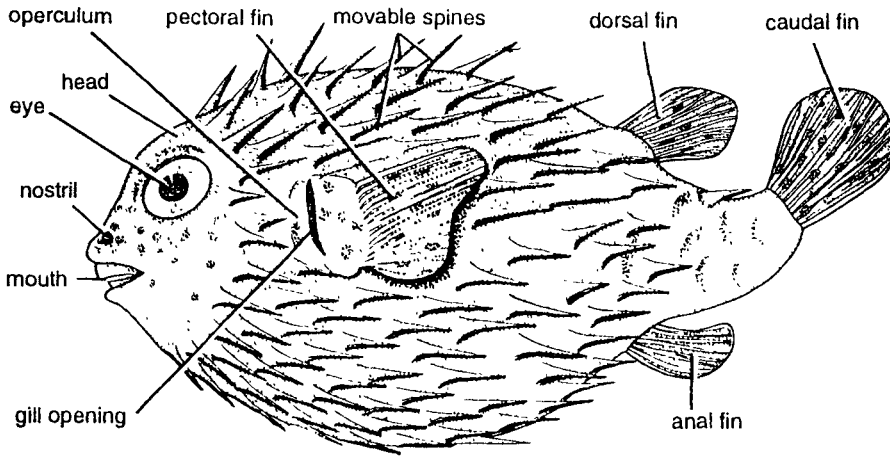

Fig. 52. *Diodon*.

**Special features :** The porcupine fishes are **poisonous** and non-edible. They attracted attention from the earliest times, as they were frequently preserved as ‘curiosities’.

**Identification :** Since this fish has flexible spines and globose body and above features, hence it is *Diodon*.

**53. *Ostracion* : Trunk Fish**

**Classification :** Same as in *Tetradon*.

Family..... Ostraciontidae

Genus..... *Ostracion*

**Geographical distribution :** *Ostracion* is chiefly distributed in tropical seas, Red Sea, African Sea, the Indian Ocean, Malaysian Archipelago, Atlantic and Pacific Oceans.

**Habit and habitat :** *Ostracion* is found in the **bottom** of shallow sea water.

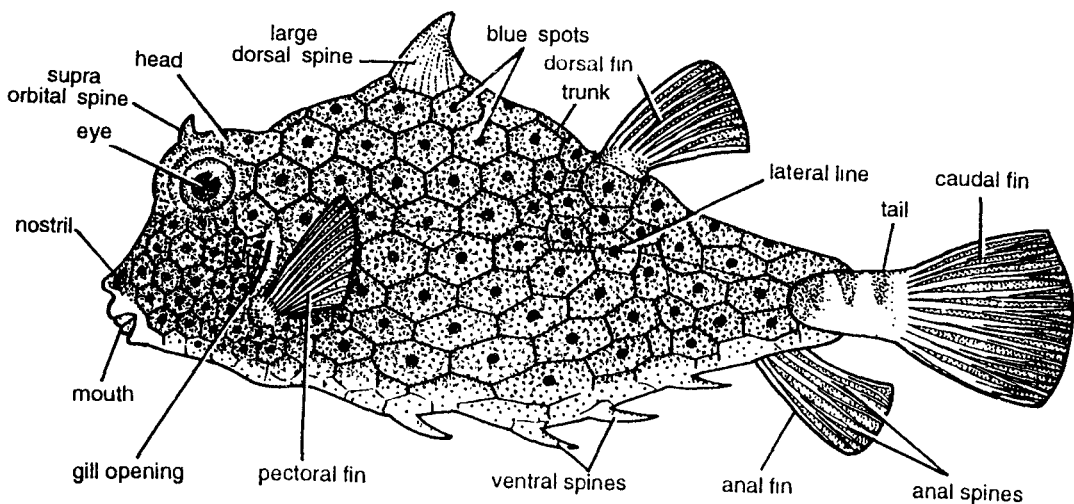

Fig. 53. *Ostracion*.

**Comments :**

- (1) Commonly known as **Trunk fish** or **Coffer fish**.
- (2) Body divided into **head, trunk** and **tail**. Head contains **mouth, nostril** and **eyes**.
- (3) Body is roughly triangular and encased in a carapace, composed of large, juxtaposed and hexagonal bony plates. Carapace is closed behind the anal fin. Fish measures about 60 cm in length.
- (4) Colour of the body is olive brown with dark bands. A light **blue spot** is present in the centre of each **scute** or **bony plate**. Ventral side contains **ventral spines**. A large dorsal spine present.
- (5) **Dorsal fin** and **anal fin** with **anal spines** present.
- (6) **Pectoral fin** is enlarged and helps to form water current. Gill opening near pectoral fin.
- (7) **Caudal fin** acts as a rudder during rapid swimming.
- (8) A compressed and small **supra-orbital spine**, directed upwards and backwards, is present above orbit.

**Special features :** Some trunk fishes are known to discharge a toxic substance termed ostracitoxin which will kill other fish in confined water. It is toxic to trunk fish itself.

**Identification :** Since this fish has bony plates and above features, hence it is *Ostracion*.

## CLASS OSTEICHTHYES

### LUNG FISHES

**Natural history**

The lung fishes deviated early from the osteolepids with whom earlier lung fishes resembled in having heavy scales, heterocercal tail, lobed fins and well ossified skull. The modern lung fishes have changed from their ancestors and are represented today by *Protopterus*, *Lepidosiren* and *Neoceratodus*. Their jaws are short, teeth form crushing plates, internal nares present, skeletal system

reduced, tail diphyrcercal and one or two lungs (air bladders) functional. The three genera are distributed discontinuously. This is the ancient group which can be regarded as Devonian offshoot from the crossopterygian stem. They first appeared in mid-Devonian, flourished moderately in the Permian and Triassic and then became rare. These show combination of primitive and advanced characters.

## 54. *Protopterus* : African Lung Fish

**Classification :**

Phylum.....	Chordata	→	Dorsal tubular nerve cord, notochord and gill-slits present.
Group.....	Craniata	→	Distinct head, cranium and brain.
Sub-phylum.....	Vertebrata	→	Vertebral column present.
Division.....	Gnathostomata	→	Jaws and paired appendages present.
Superclass.....	Pisces	→	Paired fins, gills and skin with scales.
Class.....	Osteichthyes	→	Bony fishes.
Sub-class.....	Choanichthyes	→	Nostrils connected to mouth cavity. Paired fins with larger median lobe.
Superorder.....	Dipnoi	→	Lung fish. Body long and slender. Premaxilla or maxilla absent. Air bladder lung like. Devonian to Recent.
	(Dipneusti)		
Order.....	Lepidosireniformes	→	Body ell-like, scales, small, burrowing fish.
Genus.....	<i>Protopterus</i> (African lung fish)		

**Geographical distribution :** *Protopterus* has wide distribution. It is found in the swamps of great African continent, the Nile, Congo basin, Lake Tanganyika. Devonian to Recent.

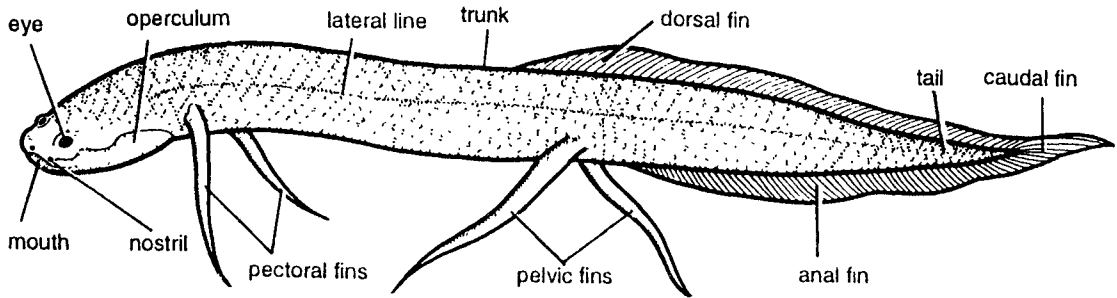
Fig. 54. *Protopterus*.

**Habit and habitat :** The fishes are adapted for **burrowing life**. They live in burrows made in muddy water. In dry season, during aestivation, they retire to vertical burrows (nests) in mud lined with mucus. It comes to surface to engulf the air.

**Comments :**

- (1) Body is elongated, cylindrical, **eel like** and is completely enclosed by small cycloid scales. Body divided into **head, trunk and tail**.
- (2) Commonly called as **African lung fish**.
- (3) **Head** contains small eyes, **nostrils** and **mouth**.
- (4) Dorsal, caudal and anal fins continuous.
- (5) **Pectorals** and **pelvic fins** are reduced to slender appendages and without fin rays.
- (6) There are six branchial arches and five clefts.
- (7) **Larval gills** are retained as vestigial organs throughout life.
- (8) There are two **lungs (air bladders)** extending throughout body cavity.
- (9) **Lateral line** well developed. Kidneys not so elongated.
- (10) Larva contains four pairs of apparent external gills. In some species vestiges of these may be found in the adult just above the opening of the operculum.

**Special features :** *Protopterus* is an **air-breather fish**. *Protopterus annectens* and 2 other species of Central Africa retire to burrow themselves in mud, where mucus dries up to form 'cocoon' with lid and a tube which is connected with the mouth of the fish for breathing. It spawns after return of water. These lung fishes show combination of primitive and specialized characters. Presence of spiral valve in the intestine, cloaca, conus and unconstricted notochord are primitive characters. While lack of ossification in the cartilaginous cranium, absence of premaxillae and maxillae and presence of dental plates on jaws are specialized characters. Presence of internal nostrils, lung respiration and autostylic suspensorium show similarity with Amphibians.

**Identification :** Since this fish has slender modified appendages and above features, hence it is *Protopterus*.

### 55. *Lepidosiren paradoxa* : American Lung Fish

**Classification :** Same as that of *Protopterus*.

Genus..... *Lepidosiren*

Species..... *paradoxa*

**Geographical distribution :** *Lepidosiren* is distributed in Amazon and Paraguay basins and plains of South America.

**Habit and habitat :** *Lepidosiren* inhabits swampy places. It makes a burrow lined by mucus in muddy water. It **aestivates** during dry season in burrow constructed for the purpose. Entrance of burrow is plugged with a mud stopper, ventilated by several round holes.

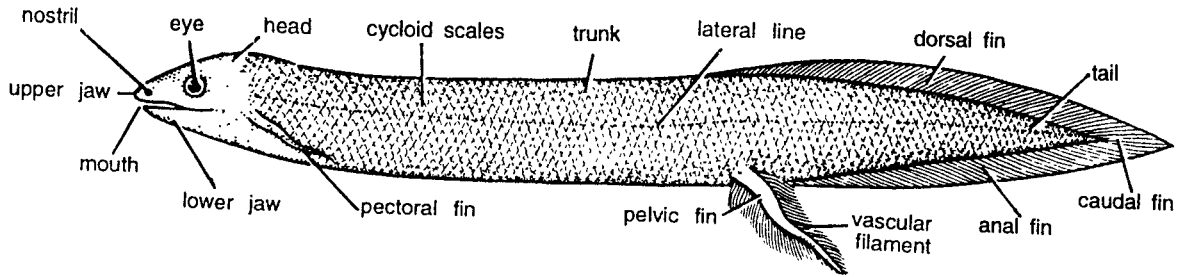

Fig. 55. *Lepidosiren*.

**Comments :**

- (1) Commonly called as **South American lung fish**. Body divided into **head, trunk** and **tail**.
- (2) Body elongated and eel-like, 3 feet in length and covered with **cycloid scales**.
- (3) **Gill slits** are 4 in number.
- (4) **Eyes** are comparatively reduced.
- (5) **Paired fins** (pectoral and pelvic) are reduced to slender styliform appendages formed of jointed axis.
- (6) During breeding season **vascular filaments** develop on the pelvic fins of the male. Filaments are considered to be respiratory. The larva possesses four gills.
- (7) Fish has two **lungs (air bladders)**.
- (8) Glottis is provided with a movable epiglottis.
- (9) **Dorsal fin, caudal fin** and **anal fin** continuous.
- (10) **Lateral line** present.

**Special features :** *Lepidosiren* shows **parental care** forming L-shaped nests. The fish aestivates in mud during dry season, but it has **no cocoon** formation habit. This lung fish also reveals combination of primitive and specialized characters. The former characters comprise of unconstricted notochord, presence of conus valve in the heart and spiral valve in the intestine. Specialized characters are absence of ossification in the cranial cartilage, premaxillae and maxillae and presence of dental plates on the jaws. *Lepidosiren* shows resemblance with Amphibia in internal nostrils, lung respiration and autostylic suspension.

**Identification :** Since this fish has reduced styliform paired appendages and above features, hence it is *Lepidosiren*.

## 56. *Neoceratodus forsteri* : Australian Lung Fish

**Classification :** Same as in *Protopterus*.

Order..... Ceratodiformes  
 Genus..... *Neoceratodus*  
 Species..... *forsteri*

**Geographical distribution :** *Neoceratodus* is found in Buret and Mary rivers of Australia and Queensland. Triassic to Cretaceous.

**Habit and habitat :** *Neoceratodus* inhabits quiet pools that become stagnant during dry season, when the fish rises to the surface to engulf fresh air into lungs. It feeds on small crustaceans and worms. It does not aestivate.

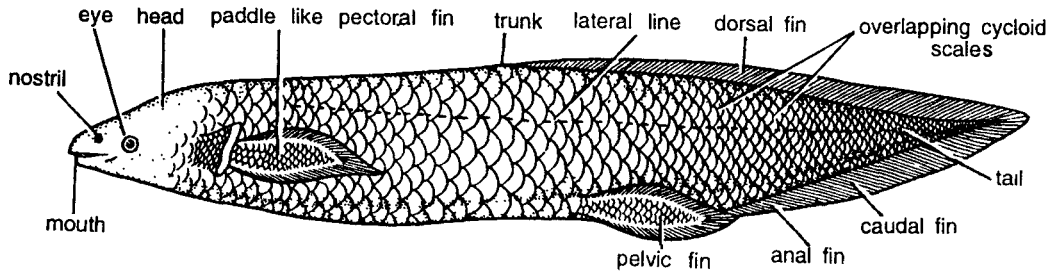

Fig. 56. *Neoceratodus forsteri*.

**Comments :**

- (1) It is a common **Australian lung-fish** (barramunda).
- (2) Body is elongated, measuring 1 to 2 metres and covered with distinct large overlapping **cycloid scales**.
- (3) Mouth is small. **Gill** slits five pairs. Body divided into **head, trunk and tail**.
- (4) **Paired fins** placed low; **paddle like paired pectoral fins** are found near head and **pelvic fins** near anal fin.
- (5) **Tail** is **diphycercal**. Dorsal fin, caudal fin and anal fin continuous.
- (6) Single pulmonary vasculated air bladder (lung) opens into oesophagus by a long duct.
- (7) Kidneys more elongated. Lateral line present.
- (8) Male does not possess vascular filament on pelvic fin. Larva is devoid of external gills.

**Special features :** *Neoceratodus forsteri* is the only living species and is considered as **living fossil**. The paired fins are modified into paddles. The skeleton of these fins is peculiar, because in each fin there is a central axis bearing radials of different sizes on both sides. The internal surface of the lung is sacculated and contains a series of **alveoli**. Lung respiration supplements gill respiration. Like *Protopterus* and *Lepidosiren*, this fish also reveals presence of primitive and specialized characters (same as in above fishes). It also shows resemblance with Amphibia in having internal nares, lungs and autostylic suspensorium.

**Identification :** Since this fish has paddle-like paired appendages and above features, hence it is *Neoceratodus*.

## CLASS AMPHIBIA

### Natural history

Amphibians mainly live in water or damp places; none in salt water. They are the commonest in moist temperate regions but some are tropical; one frog ranges into Arctic circle and tree frogs occur above 400 meters in Sierra Nevada of California. Some toads are tree toads and live in deserts, some are nocturnal. The hell bender (*Cryptobranchus*), mud puppy (*Necturus*) and Congo eel (*Amphiuma*) are strictly aquatic. Some frogs are purely arboreal. Land salamanders hide under stones and logs. Amphibians partly pass their life in water and partly on land (Gr., **amphi** = dual; **bios** = life). They are the lowest and earliest tetrapods evolving from Devonian and onwards. Amphibians have educational, experimental and food value.

### Classification

#### Class Amphibia

1. Amphibious life (on land and in water)
2. Skin moist and glandular. No Scales. Chromatophores in skin.
3. Tetrapoda, Limbs 2 pairs. Some limbless.
4. Nostrils two, connected with mouth cavity.
5. Endoskeleton bony.
6. Heart three chambered, 2 auricles and 1 ventricle.
7. Development includes tadpole larva.

#### Sub-class A. Stegocephalia

1. Limbs pentadactyle. Extinct.
2. Skin with scales and bony plates.

##### Order 1. Labyrinthodontia

1. Primitive tetrapods.
2. Teeth large and folded similar to their crossopterygian ancestors.  
Ex. *Eryops* (Extinct)

##### Order 2. Phyllospodyli

1. Small salamander-like.
2. Notochord and nerve cord housed in common cavity.  
Ex. *Branchiosaurus* (Extinct)

##### Order 3. Lepospondyli

1. Small eel-like salamanders.
2. Vertebrae of a single piece.
3. Probable ancestors to modern caecilians.  
Ex. *Diplocaulus* (Extinct).

#### Sub-class B. Lissamphibia

1. Modern amphibia.
2. Teeth small. Exoskeleton absent.
3. Respiration by lungs, skin and gills.

##### Order 1. Gymnophiona or Apoda

1. Limbless elongated burrowing caecilians.
2. Skull compact, limb girdles absent.  
Ex. *Ichthyophis*, *Uraeotyphlus*.

##### Order 2. Urodela or Caudata

1. Tailed amphibians.
2. Gills permanent or absent in adults. Paired limbs present. Larval stages resemble adults.

##### Sub-order 1. Proteida

1. Aquatic. Permanent larvae as adults with 3 pairs of gills and 2 pairs of gill slits.
2. Lungs present. Eyelids absent.  
Ex. *Proteus* (Olm), *Necturus* (Mud puppy).

##### Sub-order 2. Cryptobranchoidea

1. No gills in adults.
2. Angular and prearticular of lower jaw separate.
3. Permanently aquatic.  
Ex. *Cryptobranchus*, *Megalobatrachus*.

##### Sub-order 3. Ambystomoidea

1. Adults terrestrial with eyelids.
2. Vertebrae amphicoelous.  
Ex. *Ambystoma*.

##### Sub-order 4. Salamandroidea

1. Teeth in roof of mouth behind nares in 2 long rows.
2. Adults with lungs but no gills.  
Ex. *Triton* and *Triturus* (Newt) *Salamandra* (Salamander).

##### Sub-order 5. Amphiuoidea

1. Body cylindrical. No eyelids.
2. Adults with lungs and 1 pair of gill clefts but no gills.  
Ex. *Amphiuma* (Congo eel).

##### Sub-order 6. Sirenoidea (= Meantes)

1. Permanent larvae. Body slender.
2. Hindlegs and eyelids absent.
3. Gills persistent. Forelegs small.  
Ex. *Siren* (Mud eel), *Pseudobranchus*.

#### Order 3. Anura or Salientia

1. Frogs and toads. No tail.
2. Eyelids and tympanum present.

**CLASS AMPHIBIA**

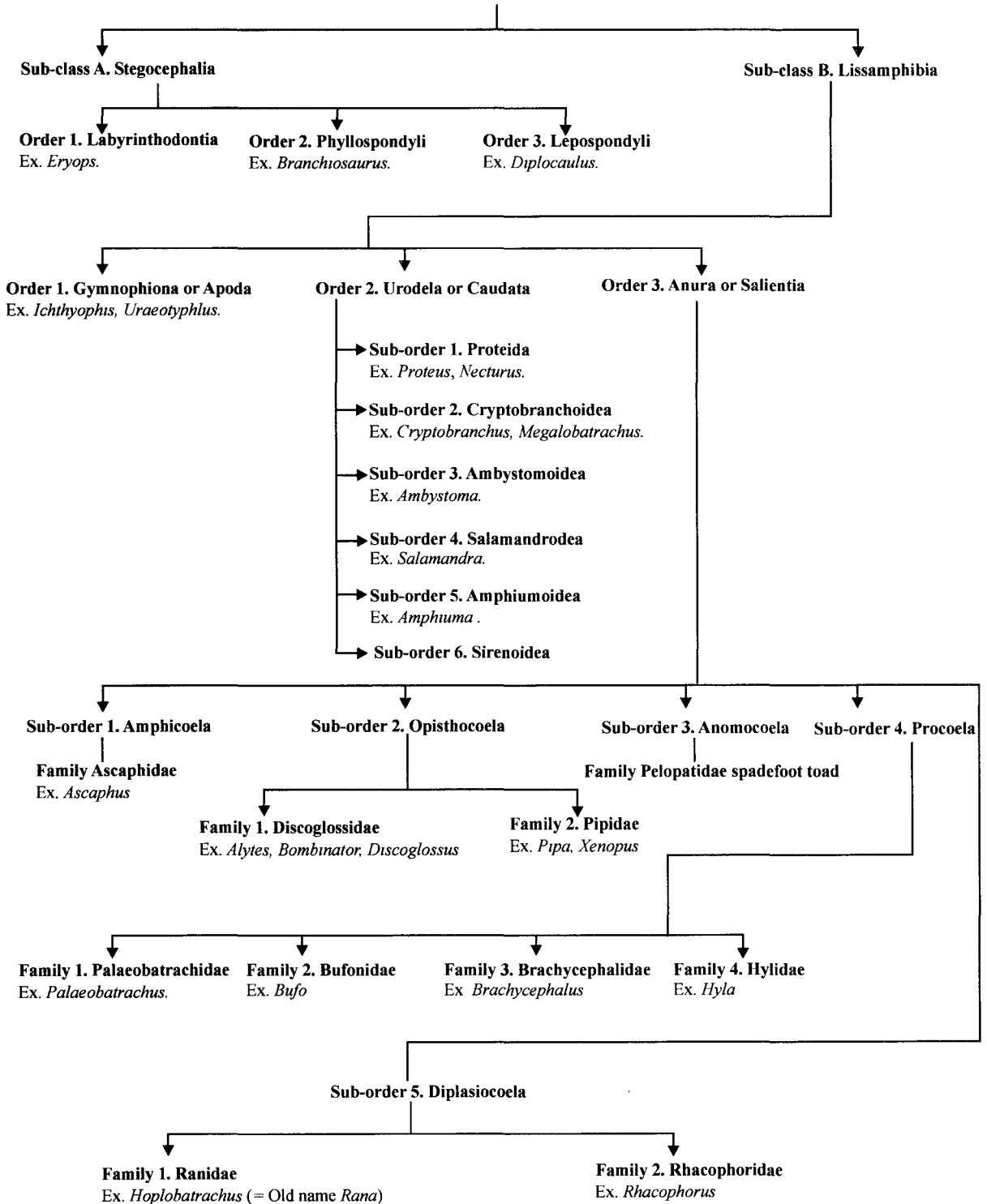



3. Forelimbs and hind limbs present.
4. Urostyle present.

**Sub-order 1. Amphicoela**

1. Vertebrae amphicoelous.
2. Fertilization internal.

**Family Ascaphidae**

1. Vertebrae connected by undivided intervertebral disc, not truly amphicoelous.
2. Presacral vertebrae 9.  
Ex. *Ascaphus*, *Liopelma*.

**Sub-order 2. Opisthocoela**

1. Vertebrae opisthocelous.
2. Ribs free in adult or larva.

**Family 1. Discoglossidae**

1. Disc-tongued toads.
2. Eyelids present.  
Ex. *Alytes*, *Bombinator*, *Discoglossus*.

**Family 2. Pipidae**

1. Tongueless toads.
2. Feet fully webbed.  
Ex. *Pipa*, *Xenopus*.

**Sub-order 3. Anomocoela**

1. Vertebrae procoelous or amphicoelous.
2. Free ossified ribs present.

**Family Pelopitidae**

1. Spadefoot toad.
2. No ribs. Teeth in upper jaw.

**Sub-order 4. Procoela**

1. Vertebrae procoelus.
2. No ribs.

**Family 1. Palaeobatrachidae**

1. Urostyle with 2 condyles.
2. Presacral 5-8.  
Ex. *Palaeobatrachus*.

**Family 2. Bufonidae**

1. True toads. No teeth.
2. A large paratoid gland behind eyes. Ex. *Bufo*, *Leptodactylus*.

**Family 3. Brachycephalidae**

1. Halves of pectoral girdles fused ventrally.
2. Bidders's organ absent.  
Ex. *Brachycephalus*.

**Family 4. Hylidae**

1. Teeth in upper or both jaws.
2. Terminal bone of each digit claw-shaped. Adhesive disc on toes.  
Ex. *Hyla*, *Gastrotheca*.

**Sub-order 5. Diplasiocoela**

1. First 7 vertebrae procoelous. 8th vertebra amphicoelous and 9th vertebra contains 2 condyles.
2. Pectoral girdle fused to sternum. Ribs absent.

**Family 1. Ranidae**

1. True frogs.
2. Teeth in upper jaw.  
Ex. *Hoplobatrachus* (= Old name *Rana*)

**Family 2. Rhacophoridae**

1. Old world frogs specialized for climbing trees.
2. Intercalary cartilage in digits meant for climbing.  
Ex. *Rhacophorus*.

**57. Ichthyophis****Classification :**

Phylum.....	Chordata	→	Dorsal tubular nerve cord, notochord and gill-slits present.
Group.....	Craniata	→	Definite head. Cranium with brain present.
Subphylum.....	Vertebrata	→	Vertebral column present.
Division.....	Gnathostomata	→	Jaws and paired appendages present.
Superclass.....	Tetrapoda	→	Paired limbs, lungs, cornified skin and bony skeleton.
Class.....	Amphibia	→	Cold blooded. Scaleless glandular skin. Can live in water and land. Two occipital condyles. Heart three-chambered.
Order.....	Gymnophiona or Apoda	→	Vermiform Amphibia without limbs or limb girdles.
Genus.....	<i>Ichthyophis</i>		

**Geographical distribution :** *Ichthyophis* is distributed in tropical regions and found in Sri Lanka, Philippines, Borneo, Java, Seychelles, Mexico to Argentina and India (Mysore) and is the only representative of Gymnophiona living today in tropical countries.

**Habit and habitat :** *Ichthyophis* lives in **burrows** and leads a fussy life in moist ground. The animal is blind and adapted for burrowing life. It feeds on invertebrates.

**Comments :**

- (1) Commonly called as **caecilian**.
- (2) Animal is worm-like and slender, measuring about 30 cm in length. Body divided into **head, trunk and tail**.
- (3) Body is covered with a smooth, slimy and transversely ringed skin consisting of small calcified scales arranged in transverse rows. **Squirt glands** in skin discharge an irritating fluid.
- (4) **Head** contains **eyes, nostrils** and a pair of **sensory tentacles**. Tympanic membrane, tympanic cavity and columella absent.
- (5) **Eyes** small, functionless and covered by skin. Though reduced but contain all the parts. A small protrusible tentacle is present between eye and nostril.
- (6) Skull compact, roofed with bone.
- (7) Limbs and limb girdles absent. Vertebrae **amphicoelous**.
- (8) Laryngotracheal chamber is prolonged into a distinct trachea. Right lung elongated, while left lung is reduced. Anus is sub-terminal.
- (9) Males are provided with **eversible copulatory organ**, which shows advanced characters. **Fertilization internal**. Male's cloaca is everted like copulatory organ. Eggs are laid in moist burrows. Mother coils around eggs till they hatch into tadpoles.

**Special features :** *Ichthyophis* resembles Amphibia in having a 3-chambered heart, conus arteriosus, urinogenital organs and brain like Amphibia. But it differs from living Amphibia in having scales in dermis and meroblastic eggs. The animal also shows parental care, as the females take care of the eggs by keeping them in the coils of the body, till they hatch. It shows combination of primitive and advanced characters. The former characters include dermal scales in the skin and number of dermal bones in the skull. Loss of limbs, short post-anal part and copulatory organs are specialized characters.

**Identification :** Since the animal is **limbless**, contains calcified scales and vestigial tail and above features, hence it is *Ichthyophis*.

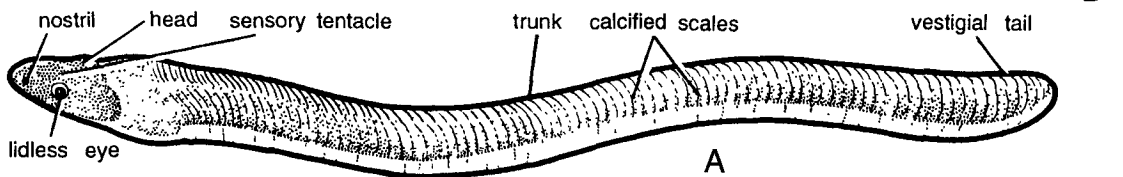

Fig. 57. A. *Ichthyophis*; B. Coiled female containing egg.

## 58. *Uraeotyphlus*

**Classification :** Same as that of *Ichthyophis*.

Genus..... *Uraeotyphlus*

**Geographical distribution :** *Uraeotyphlus* has been reported from India, Malayasia, South Africa and South America.

**Habit and habitat :** *Uraeotyphlus* also burrows in moist ground. It feeds on small worms.

**Comments :**

- (1) *Uraeotyphlus* is worm-like and elongated.
- (2) Limbs are reduced due to burrowing habit.
- (3) Body elongated, vermiform and covered with naked skin in which small dermal scales are embedded. Body divided into head, trunk and tail.

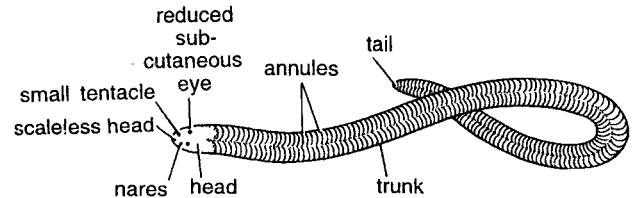

Fig. 58. *Uraeotyphlus*.

- (4) Colour of body is brown or black above and white below.
- (5) Small scaleless head contains eyes and nares.
- (6) Eyes are non-functional, indistinct and concealed beneath the slimy skin.
- (7) It has a peculiar sensory tentacular apparatus consisting of protrusible flap-shaped or globular soft tentacle lodged in a groove of maxilla between eye and nostril.
- (8) Respiration through lungs. Right lung is exceptionally large and sac-like.
- (9) Tail is extremely short. Anus sub-terminal.

**Special features :** This Apoda also reveals combination of primitive and advanced characters. The presence of dermal scales in the skin and number of dermal bones in the skull are primitive characters. While specialized characters are loss of limbs, very short post-anal part and copulatory organs.

**Identification :** Since the animal is limbless, slender and has above features, hence it is *Uraeotyphlus*.

## 59. *Necturus* : Mud Puppy

**Classification :**

Phylum.....	Chordata	→	Dorsal tubular nerve cord, notochord and gill-slits present.
Group.....	Craniata	→	Definite head. Cranium with brain present.
Subphylum.....	Vertebrate	→	Vertebral column present.
Division.....	Gnathostomata	→	Jaws and paired appendages present.
Superclass.....	Tetrapoda	→	Paired limbs, lungs, cornified skin and bony skeleton.
Class.....	Amphibia	→	Cold blooded. Scaleless glandular skin. Can live in water and land.
Order.....	Urodela or Caudata	→	Scaleless Amphibia having well developed tail, generally with two limbs, with or without external gills and gill-slits in adults.
Suborder.....	Proteida	→	Body depressed, tail with fin, gills permanent, eyelids absent, lungs present and permanently aquatic.
Family.....	Proteidae	→	3 pairs of gills and laterally compressed tail.
Genus.....	<i>Necturus</i>		

**Geographical distribution :** *Necturus* is found in North America and chiefly in Arkansas river, Carolina and Hudson rivers. Cretaceous to Recent.

**Habit and habitat :** *Necturus* is an aquatic salamander of rivers and lakes of U.S.A. It is a crawling animal on the bottom. It eats small fishes and invertebrates.

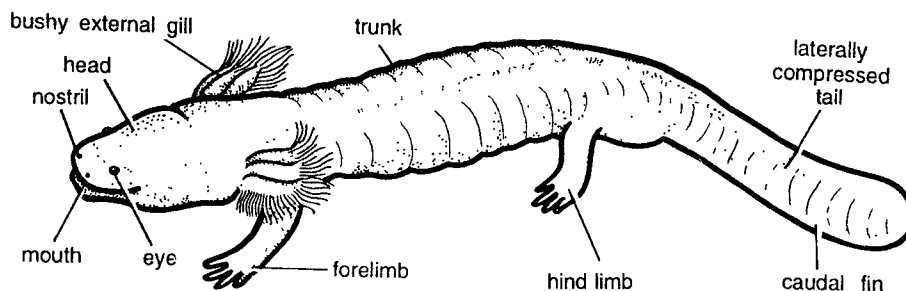
Fig. 59. *Necturus*.**Comments :**

- (1) Commonly called as **Mud puppy** or **Water dog**.
- (2) Rusty body of animal with blackish spots divided into **head**, **trunk** and **tail**, measuring about 30 to 40 cm in length.
- (3) **Head** is depressed and contains small **eyes** without eyelids, mouth and nostril.
- (4) Forelimbs and hind limbs are short and weak and provided with four digits only. First digit is lost, limbs are adapted for crawling only on the bottom of the rivers and lakes.
- (5) **Tail laterally compressed** and provided with **tail fin**. It is the main organ of progression.
- (6) **Tympanum** and organs of Jacobson absent; lungs present.
- (7) Behind the head on each side there are three **bushy, red-coloured, distinct external gills** and **two gill-slits**. Breathing is by only **external gills**.
- (8) Mud puppy mates in autumn when females take up spermatophores deposited by males; lay eggs in May or June. 18 to 180 eggs in nests attached individually by jelly stalks to undersides of stones. Nests are guarded by females. Eggs hatch in 38 to 63 days into a larva, which matures in 6 years to full size.

**Special features :** Adult is supposed to be a permanently **neotenic larva** with three pairs of **external gills**, two pairs of **gill slits**, **lateral line**, **cartilaginous skull**, with larval circulatory system and without Jacobson's organ. Experimentally, metamorphosis in *Necturus* could not be induced. It is a very interesting and favourite animal.

**Identification :** Since the above animal contains 3 pairs of external gills, laterally compressed tail and above features, hence it is *Necturus*.

## 60. *Proteus* : Olm

**Classification :** Same as that of *Necturus*.

Genus.....*Proteus*

**Geographical distribution :** *Proteus* is distributed in South Eastern Europe, Austria and Germany. Eocene to Recent.

**Habit and habitat :** *Proteus* inhabits waters of deep caves in perfect darkness in underground streams. Temperature never exceeds more than 50°F. It feeds on small crustaceans.

**Comments :**

- (1) Commonly known as **olm** or **cave salamander**.
- (2) Body is elongated, 20 to 25 cm in length and covered with unpigmented skin. Body divided into **head**, **trunk** and **tail**.
- (3) **Head** is broad. Rudimentary **eyes** sunken deep in **head** are without eyelids.
- (4) Limbs are poorly developed, a **hind limb** contains 2 digits and a **forelimb** 3 digits.

- (5) Three pairs of carmine-coloured **external gills** and two pairs of **gill-slits** are persistent. **Lungs** also present. The animal often rises to the surface, gives out a bubble of air and engulfs fresh air in lungs.
- (6) Skull cartilaginous. Both jaws have teeth. Maxillaries absent. Premaxillaries, vomers and mandibles toothed. Vertebrae amphicoelous.
- (7) **Locomotion by flattened and compressed tail** provided with **caudal fin**.

**Special features :** *Proteus* is a permanent **neotenic larva** with 3 pairs of gills. Presence of permanent tail, weak limbs, gills and gill-slits and teeth in both jaws are some of the important characters.

**Identification :** Since the animal contains 3 pairs of gills, limbs and pointed tail with tail fin and above features, hence it is *Proteus*.

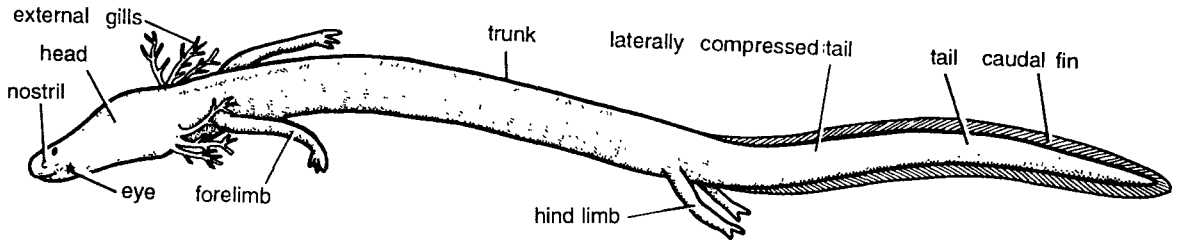

Fig. 60. *Proteus*.

## 61. *Cryptobranchus* : Hell Bender

**Classification :** Same as in *Necturus* (upto Order).

Sub-order..... *Cryptobranchioidea* → No gills in adults

Genus..... *Cryptobranchus*

**Geographical distribution :** *Cryptobranchus* is commonly found from Louisiana to Ohio (America) Japan, in Eastern Asia, and New York, Miocene to Recent.

**Habit and habitat :** *Cryptobranchus* is found in running water with rock slabs. It feeds on small worms, small fishes and crustaceans.

**Comments :**

- (1) Commonly known as **hell bender**.
- (2) Body elongated, depressed, measuring approximately 60 cm and divided into **head, trunk and tail**.

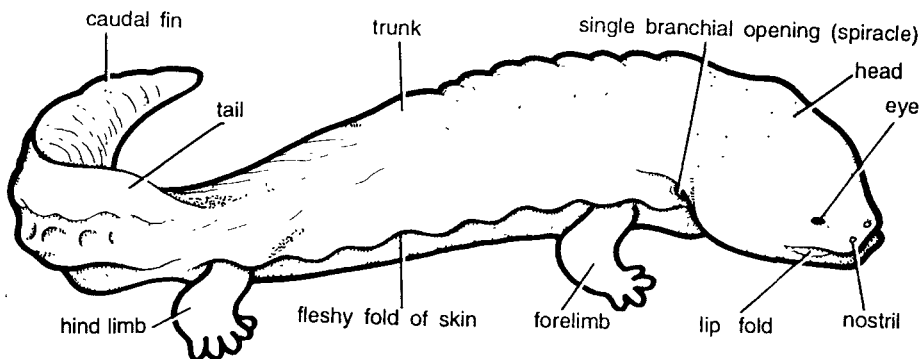

Fig. 61. *Cryptobranchus*.

- (3) Trunk and tail both contain **fleshy folds of skin**. Tail contains **caudal fin**.
- (4) **Head** is broad having **nostrils** and small eyes without eyelids.
- (5) Gills absent in adults, but the gill cleft or **spiracle** remains open and acts as excurrent opening for the water taken into the mouth during buccal respiration.
- (6) Vomerine teeth are parallel to jaws. Angular and pre-articular of lower jaw separate.
- (7) **Forelimbs** and **hind limbs** present.
- (8) **Fertilization** is **external** and breeding season is late summer. Females lay about 300 eggs in rosary-like strings and are fertilized when the males deposit sperm masses. The larvae hatch in November and take several years to mature.

**Special features** : *Cryptobranchus* has **primitive** features, such as open spiracle, absence of gills and presence of 4 epibranchials.

**Identification** : Since the animal contains peculiar fleshy folds of skin and above features, hence it is *Cryptobranchus*.

## 62. *Ambystoma maculatum* : Tiger Salamander

**Classification** : Same as in *Necturus* (upto Order).

Sub-order.....Ambystomoidea → Eye lid present Adults are terrestrial.

Genus.....*Ambystoma*

Species.....*maculatum*

**Geographical distribution** : Adult *Ambystoma* is terrestrial, found in North America, Central Mexico and the United States. Upper Cretaceous to Recent.

**Habit and habitat** : Adults are terrestrial.

**Comments** :

- (1) Commonly known as **Tiger salamander** or **Spotted salamander**.
- (2) Body is lizard-like, has transverse grooves and measures 18 to 20 cm in size. Body divisible into **head, trunk** and **tail**.
- (3) Spotted salamander (*A. maculatum*) has round yellow and orange spots over body, while Tiger salamander (*A. trigrinum*) has more spots extending over belly. **Skin poisonous**.
- (4) **Head** is depressed with large **mouth** and contains eyes and a pair of **poison glands** called **paratoids**. **External gills** and tail fin are absent. **Eyelids** and **lungs present**.
- (5) Limbs well-developed. **Forelimbs** and **hind limbs** contains 4 and 5 digits, respectively.
- (6) Prevomers short and devoid of posterior processes, teeth across rear margins of vomers. No teeth on palatine. Vertebrae **amphicoelus**.
- (7) Sexes are separate. **Fertilization internal**. Fertilized egg develops into an **Axolotl larva**.

**Special features** : The **axolotl larva** is famous for **neoteny** in which larva develops gonads and breeds like metamorphosed mature adult.

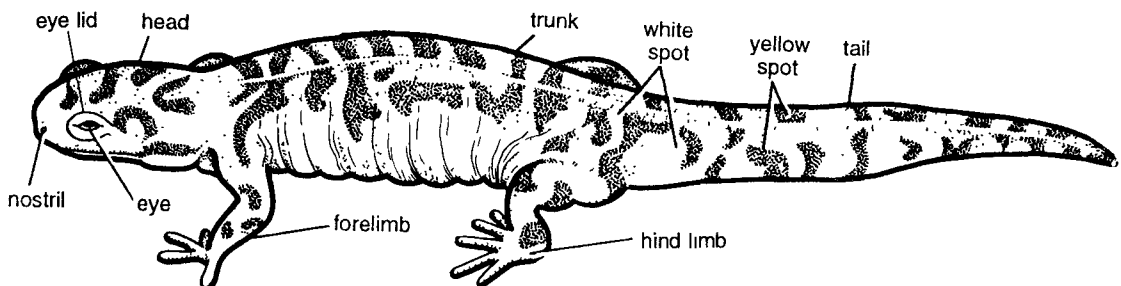

Fig. 62. *Ambystoma maculatum*.

**Identification** : Since this amphibian contains spotted skin and above features, hence it is *Ambystoma maculatum*.

### 63. Axolotl Larva

**Classification** : Same as that of *Ambystoma*.

**Comments** :

- (1) The **Axolotl larva** was previously considered as adult form and called *Siredon*. Later on it was found to be larva of *Ambystoma*.
- (2) It has 3 pairs of crimson coloured **external gills** and 4 pairs of open gill clefts. Head contains **eyes**, **nostril** and **mouth**.
- (3) Larva is **perennial**. Body measuring about 27 cm in length is divided into **head**, **trunk** and **tail**. Tail is provided with **caudal fin**. Forelimbs and hind limbs present.
- (4) It becomes sexually **mature** and **lays eggs**.
- (5) **Axolotl larva** in **captivity** metamorphoses to adult. Metamorphosis can be induced by injecting **thyroid** injections into **Axolotl** larva. **Axolotls** of six months or more are easily induced for metamorphosis. Metamorphosis to adult becomes difficult as the larva grows older. The partly metamorphosed terrestrial animals can be again induced to go back to larval stage.

**Special features** : **Axolotl** larvae of *Ambystoma* do not undergo metamorphosis if there is abundance of nutrition and oxygen supply and they develop gonads like adult to breed sexually. The phenomenon of **neoteny** or **paedogenesis** is either due to lack of iodine or heredity and environment. *A. mexicanus* is supposed to be genetically **neotenic**.

**Identification** : Since this larva has 3 pairs of gills and above features, hence it is **Axolotl larva**.

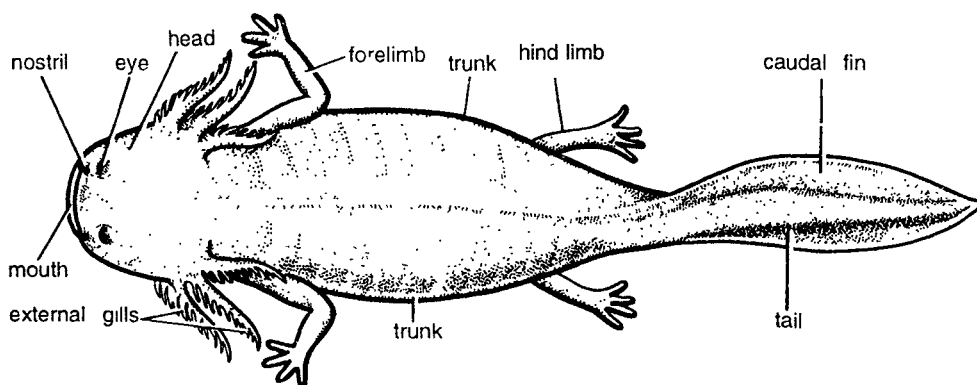

Fig. 63. Axolotl larva.

### 64. Salamandra : Fire Salamander

**Classification** : Same as in *Necturus* (upto Order).

Sub-order.....Salamandroidea → Adults without gills. Lungs present.

Genus.....*Salamander*

**Geographical distribution** : *Salamandra* is distributed in Europe, Eastern Asia and North America. Eocene to Recent.

**Habit and habitat** : Terrestrial *Salamandra* commonly found under logs, stones, cracks and crevices of the old walls.

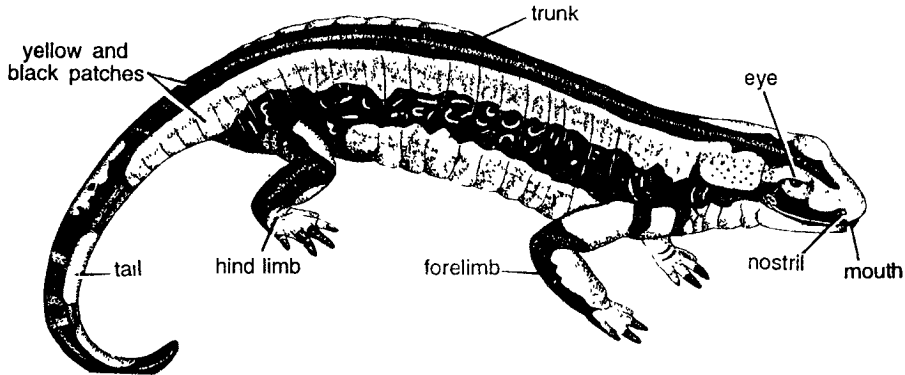
Fig. 64. *Salamandra*.**Comments :**

- (1) Commonly known as **fire salamander**.
- (2) Animal lizard like. Males measuring 12 to 15 cm in length. Females longer than males. Body divisible into **head, trunk and tail**.
- (3) Body coloured **brilliantly black with irregular patches of yellow on back and limbs**.
- (4) **Forelimbs and hind limbs** well developed and lift the body well above ground.
- (5) **Head** contains **mouth prominent eyes and nostrils**. Eyes are provided with movable eyelids. The large **paratoid glands** are present behind the head.
- (6) Tooth-bearing extensions of prevomers along parasphenoids present.
- (7) **Lungs present**. Gills and gill clefts are absent in adults.
- (8) Vertebrae **opisthocoelus**. Inter-auricular septum perforated.

**Special features :** Tail is without tail fin. Body is spotted all over. Some forms like *S. maculosa* are viviparous. The eggs develop in oviducts. Larva has gills which are shed before hatching.

**Identification :** Since this urodele has brilliantly coloured body and above features, hence it is **fire salamander**.

### 65. *Triturus cristatus* : Crested Newt

**Classification :** Same as that of *Salamandra*.

Genus..... *Triturus*

Species..... *cristatus*

**Geographical distribution :** *Triturus* is distributed in U.S.A. from California to Southern Alaska and Europe. Eocene to Recent.

**Habit and habitat :** *Triturus* is terrestrial.

**Comments :**

- (1) Commonly called as **European Crested Newt**.
- (2) Body is elongated and cylindrical and divided into **head, trunk and tail**.
- (3) Skin is soft and slimy without scales.
- (4) **Head** is conical and compressed containing **wide mouth and small nostrils**. Eyes are small with upper and lower eyelids. **Tympanum** and eardrum absent.
- (5) **Tail** is elongated, thick and provided with dorsal and ventral fins without fin rays.
- (6) **Forelimbs and hind limbs** are well developed. The former bear four, and the latter five fingers. Girdles and sternum primitive. Vertebrae opisthocoelus.



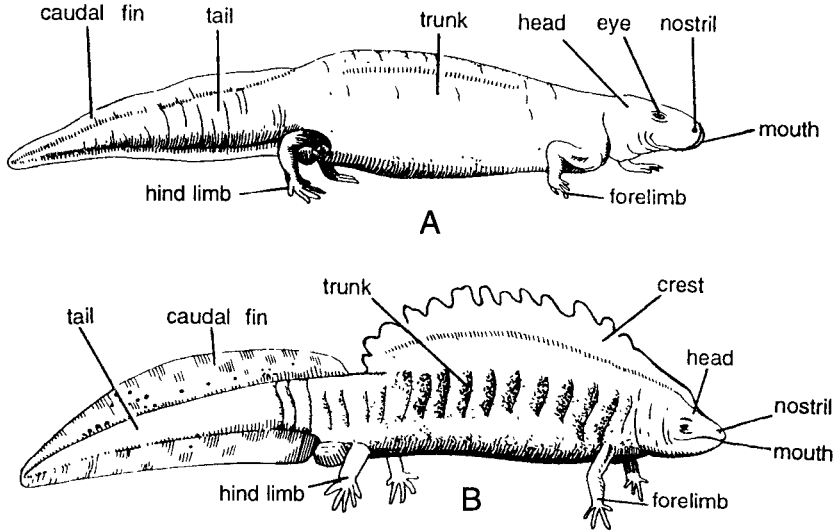

Fig. 65. *Triturus cristatus*, A. Female, B. Male.

- (7) **Gills** are absent; respiration by skin and lungs.
- (8) Alimentary canal, excretory duct and gonadal ducts open into the cloaca.
- (9) It exhibits marked **sexual dimorphism**. Male develops **crest** on the back and becomes brilliantly coloured in breeding season. Larval stage is provided with three pairs of gills which are lost in the adult.

**Identification** : Since this urodele has thick tail and crest in male and above features, hence it is *Triturus*.

## 66. *Amphiuma* : Congo Eel

**Classification** : As in *Necturus* (upto Order).

Sub-order..... *Amphiumoidea* → Body cylindrical. No eye lids.

Genus..... *Amphiuma*

**Geographical distribution** : *Amphiuma* is distributed in Missouri and Virginia (United States). Eocene to Recent.

**Habit and habitat** : *Amphiuma* is commonly found in swampy meadows and rice fields. It feeds on molluscs, crayfishes and small fishes.

**Comments** :

- (1) Commonly known as **Congo eel**.
- (2) Body is covered with smooth and black skin. The animal measuring about 90 cm is divided into **head**, **trunk** and **tail**. Head contains **eyes**, **nostrils** and **mouth**.

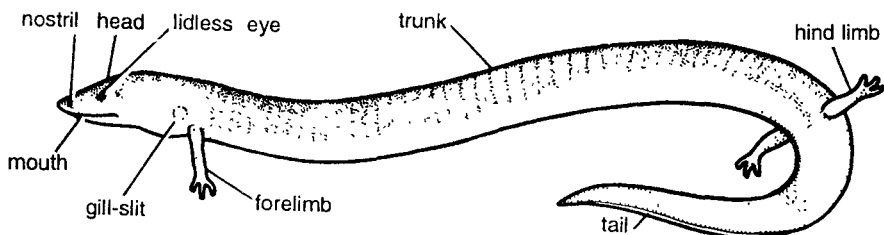

(Z-21)

Fig. 66. *Amphiuma*.

- (3) **Eyes** are well developed and functional, but without eyelids.
- (4) **Forelimbs** and **hind limbs** poorly developed and do not help in locomotion.
- (5) Gill clefts are two in number but no gills. Lungs are present. Trachea is long.
- (6) Eggs are laid in water and female coils around the eggs till they hatch.

**Special features :** *Amphiuma* is also a **perennial**, partly metamorphosed salamandrid derivation with small eyes. It shows **parental care**. It has retained several larval characters such as lidless eyes, parallel arrangement of maxillary and vomerine teeth, four branchial arches and amphicoelus vertebrae. According to Ponder (1924), this animal has largest erythrocytes, measuring 80 microns.

**Identification :** Since this urodele has lidless eyes and above features, hence it is *Amphiuma*.

## 67. *Siren* : Mud Eel

**Classification :** Same as in *Necturus*.

Suborder..... Meantes or Sirenidea. → Permanent larval form.

Genus..... *Siren*

**Geographical distribution :** *Siren* is found in the United States, chiefly in Virginia, Indiana, Florida and Texas. Pleistocene to Recent.

**Habit and habitat :** *Siren lacortina* is found in the burrows, muddy ditches and ponds.

**Comments :**

- (1) Commonly known as **mud eel**.
- (2) Body is slender, elongated, 75 cm in length, covered with small papillae and divided into **head**, **trunk** and **tail**.
- (3) Head is conical with small **eyes** and **nostrils**. **Eyes** are without eyelids.
- (4) **Forelimbs** are small containing 4 **digits** while **hind limbs** are **absent**.
- (5) **Tail** is provided with small caudal fin.
- (6) **Jaws** with horny covering.
- (7) There are three pairs of **external gills** which are persistent. Gill-slits one pair.
- (8) Cloacal glands are absent. Fertilization is probably external.

**Special features :** *Siren* is also a **permanent larval form** with only a few adult features. Larvae do not undergo complete metamorphosis.

**Identification :** Since this urodele has slender body, gills, only forelimbs and above features, hence it is *Siren*.

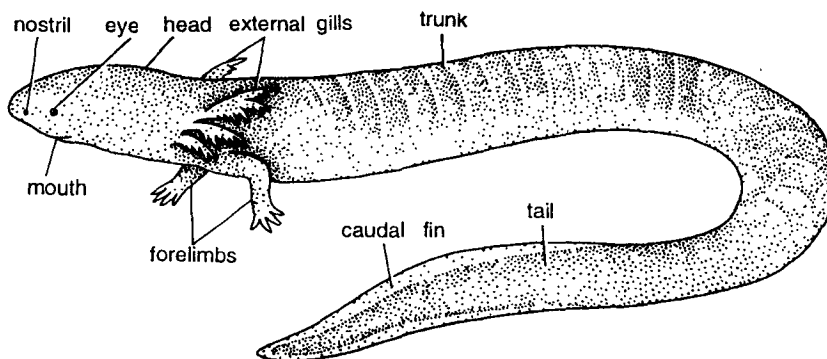

Fig. 67. *Siren*.

## 68. *Bombinator* : Fire-bellied Toad

### Classification :

Phylum.....	Chordata	→	Dorsal tubular nerve cord, notochord, and gill-slits present.
Group.....	Craniata	→	Definite head. Cranium with brain present.
Subphylum.....	Vertebrata	→	Vertebral column present.
Division.....	Gnathostomata	→	Jaws and paired appendages present
Superclass.....	Tetrapoda	→	Paired limbs, lungs, cornified skin and bony skeleton.
Class.....	Amphibia	→	Cold blooded. Scaleless glandular skin. Can live in water and land. Two occipital condyles. Heart three-chambered.
Order.....	Anura or Salientia	→	Scaleless Amphibia. Tail, external gills and gill-slits absent. Both hind limbs and forelimbs well developed.
Suborder.....	Opisthocoela	→	Vertebrae opisthocoelous, ribs free.
Family.....	Discoglossidae	→	Tongue and eyelids present. Adults with ribs.
Genus.....	<i>Bombinator</i>		

**Geographical distribution :** *Bombinator* is found in Europe, Eurasia and China. Miocene.

**Habit and habitat :** *Bombinator* lives in standing water with **hygrophytic vegetation**.

### Comments :

- (1) Commonly known as **fire-bellied toad**.
- (2) Body measures about 5 cm and divided into **head and trunk**.
- (3) Head contains eyes and nostril.
- (4) Dorsal surface is black or grey, while ventral surface is bluish black with irregular red or orange patches.
- (5) **Forelimbs** and **hind limbs** are well developed. Hind limbs are enlarged for leaping. **Webbed toes**.
- (6) Tongue and eyelids present.
- (7) **Tympanic membranes** and vocal sacs are absent. Eustachian tube is small.
- (8) Vertebrae opisthocoelous. Adults have ribs.
- (9) Egg deposition and fertilization external by 'clasped' male and female. Larva is a **tadpole**.

**Special features :** *Bombinator ignem* is common fire-bellied toad. The abdomen and entire ventral surface is brilliantly coloured with bluish-black and irregular red or orange patches. Dorsal surface grey or olive-black. When disturbed, it exposes its belly against the enemies. The shaking water gives a flame-like appearance and hence called as fire-bellied toad. When the toad is disturbed on land, head is thrown back, limbs turned upwards, belly is exposed with coloured patches and teeth produce hissing sound.

**Identification :** Since this Anura contains coloured patches on abdomen and above features, hence it is *Bombinator*.

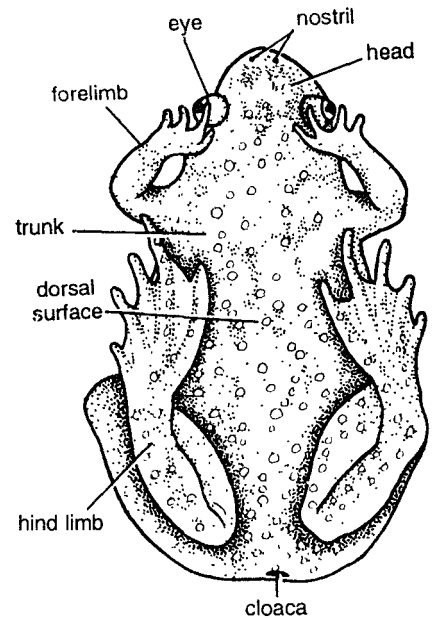

Fig. 68. *Bombinator*.

## 69. *Alytes* : Midwife Toad

**Classification :** -As that of *Bombinator*.

Genus.....*Alytes*

**Geographical distribution :** *Alytes* is found in European countries. Miocene.

**Habit and habitat :** *Alytes* is an amphibious toad.

(Z-21)

**Comments :**

- (1) Commonly known as **Midwife toad**.
- (2) Body measures 5 to 8 cm in length and divided into **head** and **trunk**.
- (3) Body surface is **warty** and grey, brown, green or red coloured.
- (4) **Head** contains large **tympanum** and **protuberant eyes**.
- (5) Tongue is in the form of rounded non-protrusible disc.
- (6) Males are without **vocal sacs**.
- (7) Larva contains median spiracle.
- (8) Upper jaw toothed, and transverse process of sacral vertebrae dilated. Vertebrae **opisthocoelous**. Adults have ribs.
- (9) Fertilization and egg deposition **external**.

**Special features :** The midwife toad has peculiar **breeding habit**. The male toad massages the cloaca

of female with strokes of its toes for sexual stimulation and the female lays eggs in strings. The male sprays sperms over the eggs for fertilization of eggs. The male toad winds strings containing eggs around its posterior body and thighs and it goes in moist earth. Occasionally, the male toad comes in water for dip to moisten the eggs. When eggs develop into tadpole stage and are ready for hatching, the toad goes in water and larvae hatch. This shows **extraordinary parental care**.

**Identification :** Since this Anura has eggs on back and above features, hence it is *Alytes*.

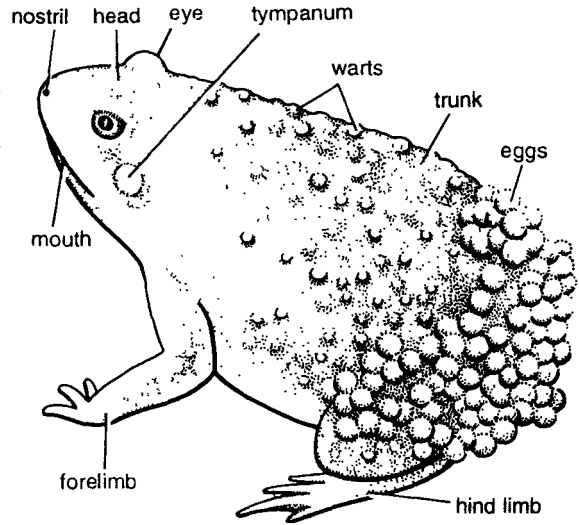

**Fig. 69.** *Alytes* : Male with eggs.

## 70. *Pipa* : Surinam Toad

**Classification :** Same as in *Bombinator*.

Genus..... *Pipa*

**Geographical distribution :** *Pipa* is commonly found in North as well as South America, Miocene.

**Habit and habitat :** *Pipa* is strictly aquatic.

**Comments :**

- (1) Commonly known as **Surinam toad**.
- (2) Animal has shabby looks with a triangular and depressed **head** and **large trunk**. Head contains small **eyes**. Tongue and eyelids are absent.
- (3) Dermal papillae are present. Skin contains **poison glands**.
- (4) Forelimbs are small and papillae star-shaped, having sensory processes, while hind limbs are **fully webbed**.
- (5) Upper part of snout is produced into irregular **flaps** and **tentacles**.
- (6) Jaws do not contain teeth, but have horny substitute.
- (7) Eustachian tube opens into pharynx.
- (8) Vertebrae **opisthocoelous**.

**Special features :** The breeding habit is peculiar. Female toad shows **parental care**. During breeding season, the skin of female becomes soft. The male clasps the female and presses the female and eggs come out. The male also releases sperms which fertilize eggs. The fertilized eggs attach to the back of the female. Each egg is enclosed in a vascular pouch covered with operculum. The embryo develops

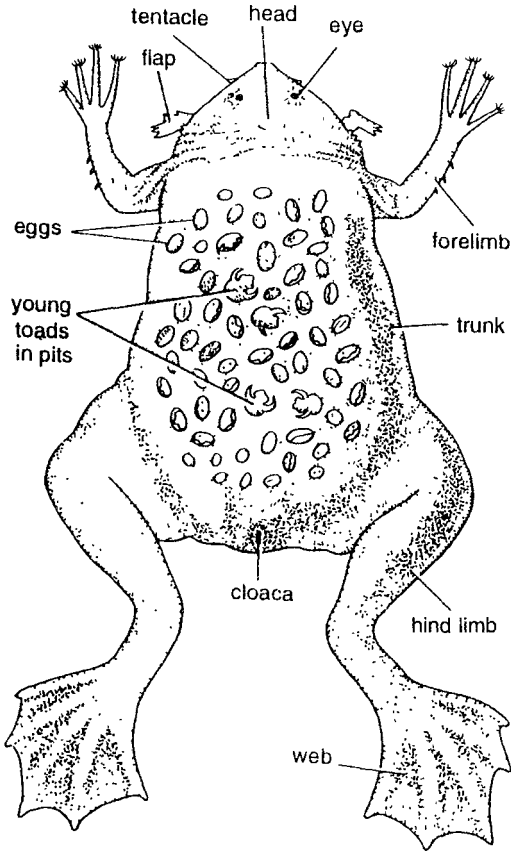

Fig. 70. *Pipa americana*.

yolk sac and vascular tail for exchange of metabolites. Gills are not formed and fully-developed young ones come out from the pouch. The female changes its back skin after the young escape.

**Identification :** Since this Anura contains small head and above features, hence it is *Pipa americana*.

## 71. *Bufo* : Common Toad

**Classification :** Same as in *Bombinator* (upto Order).

Sub-order..... Procoela

Genus..... *Bufo*

**Geographical distribution :** *Bufo* has world-wide distribution. They are abundantly found in India, United States and Pacific State of Alaska. Miocene.

**Habit and habitat :** *Bufo* is terrestrial, nocturnal, hiding under logs and stones or in burrows in day. It enters water only to breed and spawn.

**Comments :**

- (1) Commonly called as **true toad**.
- (2) It differs from frog in having rough, dry and warty skin with more **poison glands** than **mucous glands**. The skin is more or less of protective nature than respiratory.
- (3) Body divided into **head** and **trunk**. Head contains **mouth** large **eyes**, **nostrils** and **tympanum**.
- (4) Behind eyes there is a pair of large **parotid poison glands**.

- (5) **Hind limbs** contain 4 **claw like digits** and **thumb pads** or adhesive pads.
- (6) **Forelimbs** and **Hind limbs** are short. Toes provided with horny tips and poorly developed webs.
- (7) Maxillary teeth, sternum absent and ventral parts of pectoral girdle overlap (arciferous). Sacral vertebra has dilated transverse processes. Vertebrae procoelus. Urostyle with double condyle.
- (8) Liver is bilobed. **Glands of swammerdams** absent.
- (9) **Eggs** are **pigmented** and laid in **gelatinous string**. Young toads mature in many years.

**Special features** : The parotid glands of the toad secrete two toxic substances, **bufotalus** and **bufogus**.

These toxins cause nausea, respiratory and muscular disturbances and also effect heart functioning, if swallowed by man. *Bufo melanostictus* is found upto 3000 meters in the Himalayas.

**Identification** : Since this Anura contains parotid glands and above features, hence it is *Bufo*.

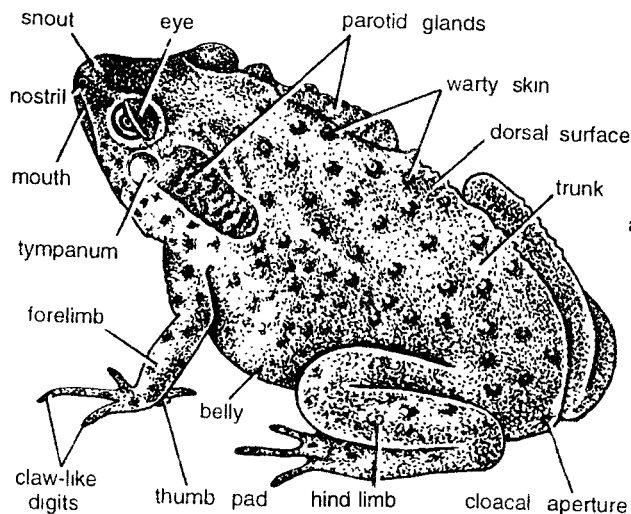

Fig. 71. *Bufo*.

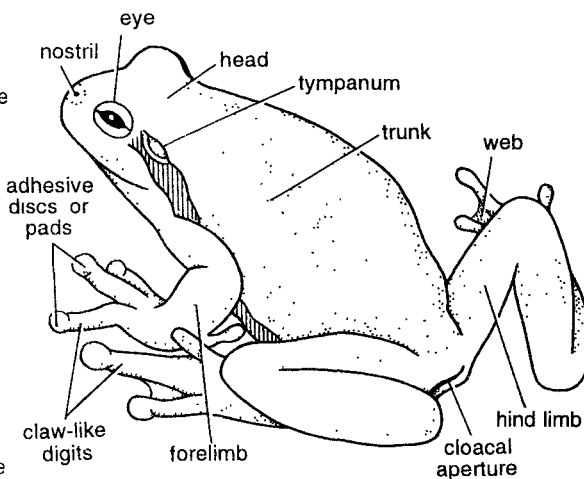

Fig. 72. *Hyla*.

## 72. *Hyla* : Tree Frog

**Classification** : Same as in *Bombinator*.

Sub-order.....Procel

Family.....Hylidae

Genus.....*Hyla*

**Geographical distribution** : *Hyla* is commonly distributed in India, China, United States, Africa and Canada. Miocene.

**Habit and habitat** : *Hyla* is arboreal in habit, living on trees and rocks.

**Comments** :

- (1) Commonly known as **tree frog**.
- (2) Body measuring 3 to 8 cm in size and divided into **head** and **trunk**.
- (3) **Head** contains **eyes** and **nostrils**.
- (4) **Forelimbs** and **hind limbs** adapted for arboreal life. Terminal base of each digit is claw shaped and **toes** contain expanded adhesive discs or **cushions** which are used to climb trees.
- (5) **Eyes** well developed with horizontal pupil. **Tympanum** distinct. Voice often loud.
- (6) Skin of belly contains **hygroscopic glands** which help in adhering the frog with leaf, twigs or stem.
- (7) Upper jaw toothed, lower jaw without teeth (**edentulus**).
- (8) Transverse processes of sacral vertebra are dilated.
- (9) **Fertilization external**. Eggs are laid in water. Development includes tadpole larva.

**Special features :** *Hyla arborea*, *Hyla versicolour* and *Hyla regita*, etc., are all tree-living frogs, and adapted from amphibious to arboreal life. They also **change** their colour according to their environment and show camouflage or mimicry. *Hyla faber* shows peculiar parental care. It comes down from the tree. Females dig up mud of shallow pond, make small nurseries, and eggs are laid in them. The larvae hatch and go into submerged water.

**Identification :** Since this Anura contains adhesive discs in limb toes and above features, hence it is *Hyla*.

### 73. *Rhacophorus* : Flying Frog

**Classification :** Same as in *Bombinator* (upto Order).

**Suborder.....** *Diplasiocoela* → First 7 vertebrae procoelus 8<sup>th</sup> amphicoelus and 9<sup>th</sup> contains 2 condyles.

**Genus.....** *Rhacophorus*

**Geographical distribution :** The tree frogs or flying frogs are found in Africa, South Eastern Asia, Japan and Madagascar. Miocene.

**Habit and habitat :** *Rhacophorus* is a **tree-living frog**. It remains calm and quiet under stones or on trees and comes out during twilight. It has power of rapid colour changing.

**Comments :**

- (1) Commonly known as **flying frog** or **tree frog**.
- (2) Body slender, divided into **head** and **trunk**. Belly narrows posteriorly. Females larger than males.
- (3) **Head** broad and somewhat conical containing eye lids. **Eyelids** well developed. **Tympanum** behind eyes.
- (4) Limbs elongated and contain well-developed **webs in digits** which also bear **adhesive cushions at tips**. Digits of hind limbs also contain **intercalary cartilages**.
- (5) The flying frogs climb on trees and walls and occasionally glide and while alighting on ground, the webs are spread like parachute.
- (6) Eggs laid usually in gelatinous foam over shallow water of pools and rice fields.

**Special features :** *Rhacophorus* shows extreme degree of **adaptive radiation** in frogs as it has acquired the power of flying or parachuting while alighting from trees. It shows parental care. *Rhacophorus schlegeli* has evolved a novel technique to care for its eggs. The copulating males and females burrow deep into the ground on the bank of the standing pond. Eggs are laid in froth and parents retire through a tunnel they dig behind which slopes down to open in pond. The froth settles down and turns into a fluid shortly before larvae hatch and slip into the pond.

**Identification :** Since this Anura contains well developed webs and above features, hence it is *Rhacophorus*.

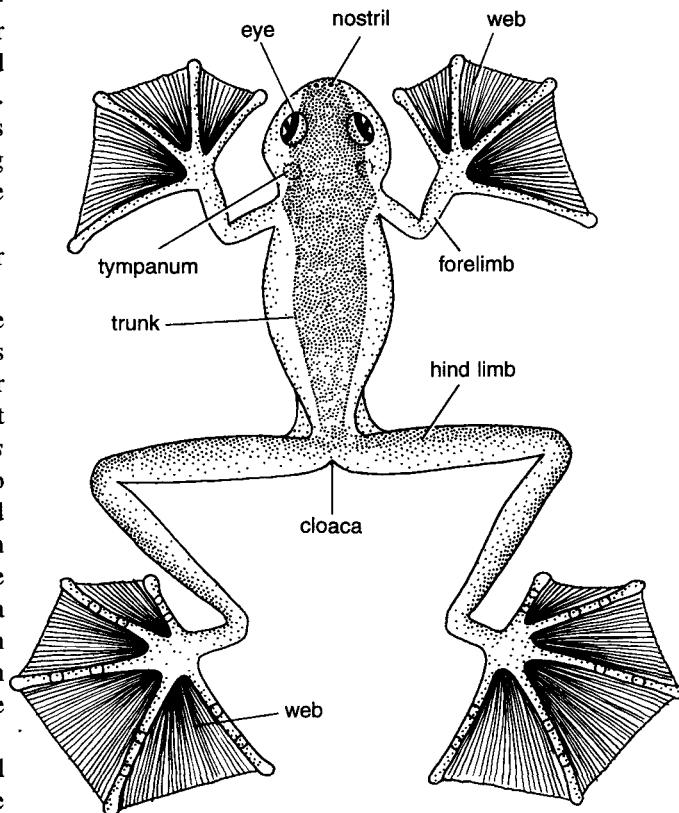

Fig. 73. *Rhacophorus*.

## CLASS REPTILIA

### Natural history

Class Reptilia includes the **turtles** and **tortoises** (order Chelonia), **lizards** and **snakes** (order Squamata), **crocodiles** and **alligators** (order Crocodylia) and **tuatara** (order Rhynchocephalia). These represent only 4 of the 16 orders that lived and flourished in **Mesozoic era**. Reptiles are first vertebrates adapted for life on dry land. The class name refers to the mode of travel (Latin *reptum*=to creep). Reptiles show advance over the amphibians in having (i) dry scaly body covering, adapted to life away from water, (ii) limbs suited for rapid locomotion, (iii) further separation of oxygenated and non-oxygenated blood in the heart, (iv) complete ossification of skeleton, and (v) eggs suited for development on land with membranes.

Most reptiles live in tropical and subtropical regions, their number declining towards poles. Turtles and snakes are abundant in humid regions. Reptiles have radiated towards all kinds of habitat, *i.e.*, land, water and air. In winter they lead dormant life, hibernate in crevices. Snakes are injurious to mankind and still man fears them very much. Many kinds of snakes and lizards benefit man by providing food, by destroying harmful rodents and insects. Skin of snakes and crocodiles is of great economic importance.

### Expanded classification

#### Class Reptilia

1. Body covered with dry skin.
2. Horny epidermal scales, shields, plates and scutes form exoskeleton.
3. Hind and forelimbs present. Digits with horny claws.
4. Single occipital condyle.
5. Bony endoskeleton.
6. Fertilization internal.

##### Sub-class A. Anapsida

1. Skull roof solid.
2. No temporal opening behind eye.

##### Order 1. Cotylosauria

1. Primitive reptiles.
2. Resemble Labyrinthodont amphibians.  
Ex. *Seymouria*.

##### Order 2. Chelonia

1. Body broad, covered with a firm shell of rounded dorsal carapace and flat-ventral plastron.
2. No teeth. Jaws with horny sheath.

##### Sub-order 1. Atheca – Extinct

##### Sub-order 2. Thecaphora

1. Neck bends in vertical scurve if retractile.
2. Pelvis not fused with plastron.

##### Family 1. Testudinidae

1. Shell usually complete with scutes.
2. Limbs with claws, not paddle-like.  
Ex. *Chrysemys*, *Terrapene*, *Testudo*, *Kachuga*.

##### Family 2. Chelonidae

1. Limbs flipper-like, shell shield smooth.
2. Horny scutes large.  
Ex. *Chelonia*, *Coretta*, *Chelone*.

##### Family 3. Trionychoidae

1. Soft, shelled turtles.
2. Shell reduced covered by skin.  
Ex. *Trionyx*.

##### Sub-class B. Eurypsida

1. Skull with single dorsolateral temporal opening bounded by post-orbital and squamosal.
2. Extinct.

Ex. *Plesiosaurus*.

##### Sub-class C. Parapsida

1. Dorsolateral temporal opening in skull bounded by supra-temporal and post Frontal.
2. Extinct.

Ex. *Ichthyosaurus*.

##### Sub-class D. Synapsida

1. Skull roof with lower opening behind eye bounded above by post-orbital and squamosal.
2. Extinct mammal-like reptiles.

Ex. *Dimetrodon*, *Varanosaurus*.

##### Sub-class E. Diapsida

1. Skull roof with 2 openings behind eye separated by a bar formed by post-orbital and squamosal.
2. No antero-orbital opening or depression.

##### Order 1. Rhynchocephalia

1. Living reptiles, lizard-like.
2. Scales granular, a mid-dorsal row of long spines.  
Ex. *Sphenodon*.

##### Order 2. Squamata

1. Lizards and snakes.
2. Skin with horny epidermal scales or shields.

##### Sub-order 1. Sauria or Lacertilia

1. Lizards. Body slender. Limbs typically 4.
2. Eyelids movable.

##### Family 1. Geckonidae

1. Toes often with rounded adhesive pads.
2. Tongue protrusible.  
Ex. *Gecko*, *Hemidactylus*.

##### Family 2. Iguanidae

1. Limbs normal. Teeth homodont. (alike). New world lizards.
2. Tongue fleshy, non-protrusible  
Ex. *Anolis*, *Phrynosoma*, *Sauromalus*, *Iguana*, *Crotaphytus*.

##### Family 3. Agamidae

1. Limbs normal. Teeth differentiated. Old world lizards.
2. Tongue short and thick.  
Ex. *Agama*, *Draco*, *Moloch*, *Calotes*.



**Family 4. Scincidae**

1. Limbs and toes often reduced sometimes absent.
2. Scales commonly smooth.
3. Skinks.  
Ex. *Mobouia*.

**Family 5. Chamaeleonidae**

1. Head angular produced into snout.
2. Tail prehensile. Changes colour.  
Ex. *Chamaeleon*.

**Family 6. Varanidae**

1. Large trunk. Limbs stout. Neck and tail long. Monitors.
2. Teeth pleurodont. Tongue long bifid and protrusible.  
Ex. *Varanus*.

**Family 7. Helodermidae**

1. Poisonous lizards. Rounded limbs. Trunk and tail stout.
2. Tongue fleshy and protrusible.
3. Venom potent, fatal to small animals, rarely to man.  
Ex. *Heloderma*.

**Family 8. Anguinae**

1. Alligator lizards. Body slender with deep fold in skin on each side.
2. Limbs small or none. Tail long, fragile and regenerates.  
Ex. *Anguis*, *Ophiosaurus*.

**Sub-order 2. Ophidia or Serpentes**

1. Snakes, limbs, feet, ear openings, sternum and urinary bladder absent.
2. Mandibles joined anteriorly by ligament.
3. Poisonous and non-poisonous snakes.

**Family 1. Typhlopidae**

1. Eyes vestigial under opaque scales, teeth on maxillary bones only.
2. Scales thin, overlapping.  
Ex. Blind snakes. *Typhlops*.

**Family 2. Leptotyphlopidae**

1. Teeth only on lower jaw.
2. Vestiges of femur and all pelvic bones present.  
Ex. *Leptotyphlops*.

**Family 3. Boidae**

1. Vestiges of pelvic girdle and hind limbs as 2 spurs on ventral sides.
2. Cosmopolitan.  
Ex. *Python molurus*, *Eryx*.

**Family 4. Aniliidae**

1. Head small, cranium firm.
2. Tail short, scales smooth.  
Ex. *Anilius*, *Cylindrophus*.

**Family 5. Uropeltidae**

1. Head small and pointed. Tail short, shield tailed snakes.
2. No vestiges of hind limbs and pelvic girdle.  
Ex. *Uropeltis*.

**Family 6. Colubridae**

1. Facial bones movable, squamosal loosely attached to articular.
2. Both jaws with teeth but no elaborate fangs.  
Ex. *Ptyasmucosus*, *Matrix*, *Dendrophis*.

**Family 7. Dasypeltidae**

1. Ventral spine on anterior vertebrae used to crack shells of birds eggs.
2. Teeth long and slender.  
Ex. *Elachistodon*, *Dipsas*.

**Family 8. Hydrophiidae**

1. Tail compressed, used for swimming, venomous and dangerous to man.
2. A pair of short, rigid, erect venom-conducting teeth or fangs.  
Ex. Sea snakes. *Hydrophis*, *Pelamis*.

**Family 9. Elapidae**

1. 2 or more short, rigid, erect fangs. Venom powerful and dangerous to man.
2. Tail round and tapered, not compressed.  
Ex. Poisonous snakes. *Bungarus*, *Naja-naja*, *Elaps*.

**Family 10. Viperidae**

1. Paired erectile fangs in front of upper jaw, one on each maxillary bone and folded backward when not in use. Venomous.
2. No pit between nostril and eye.  
Ex. *Vipera russelii* (Pitless viper)

**Family 11. Crotalidae**

1. A pit like depression on each side of upper jaw between nostril and eye.
2. Some with horny rattle at end of tail.  
Ex. *Ancistrodon* (Pitviper), Rattlesnake.

**Order 3. Crocodylia**

1. Body long, head large and long.
2. Jaws powerful with numerous bluntly conical teeth.
3. Short limbs ending into claws with web.
4. Tail long heavy and compressed.
5. Heart 4-chambered with separate ventricles.  
Ex. Crocodile (*Crocodylus*), Gavials (*Gavialis*), Alligators (*Alligator*).

**Order 4. Pseudosauria**

Extinct. Ex. *Saltopseudois*.

**Order 5. Saurischia**

1. Ischium and pubis diverge.
2. Bipedal or huge 4-footed.  
Ex. (Extinct) Dinosaurs, *Tyrannosaurus*, *Brontosaurus*, *Diplodiscus*.

**Order 6. Ornithischia**

1. Pelvis bird-like.
2. Ischium and pubis together.  
Extinct. Ex. Dinosaurs, *Iguanodon*, *Triceratops*, *Stegosaurus*.

**Order 7. Pterosauria**

1. Flying reptiles.
2. Forelimbs with wing membranes. Tail long.  
Ex. (Extinct) *Pteranodon*, *Rhamphorhynchus*.

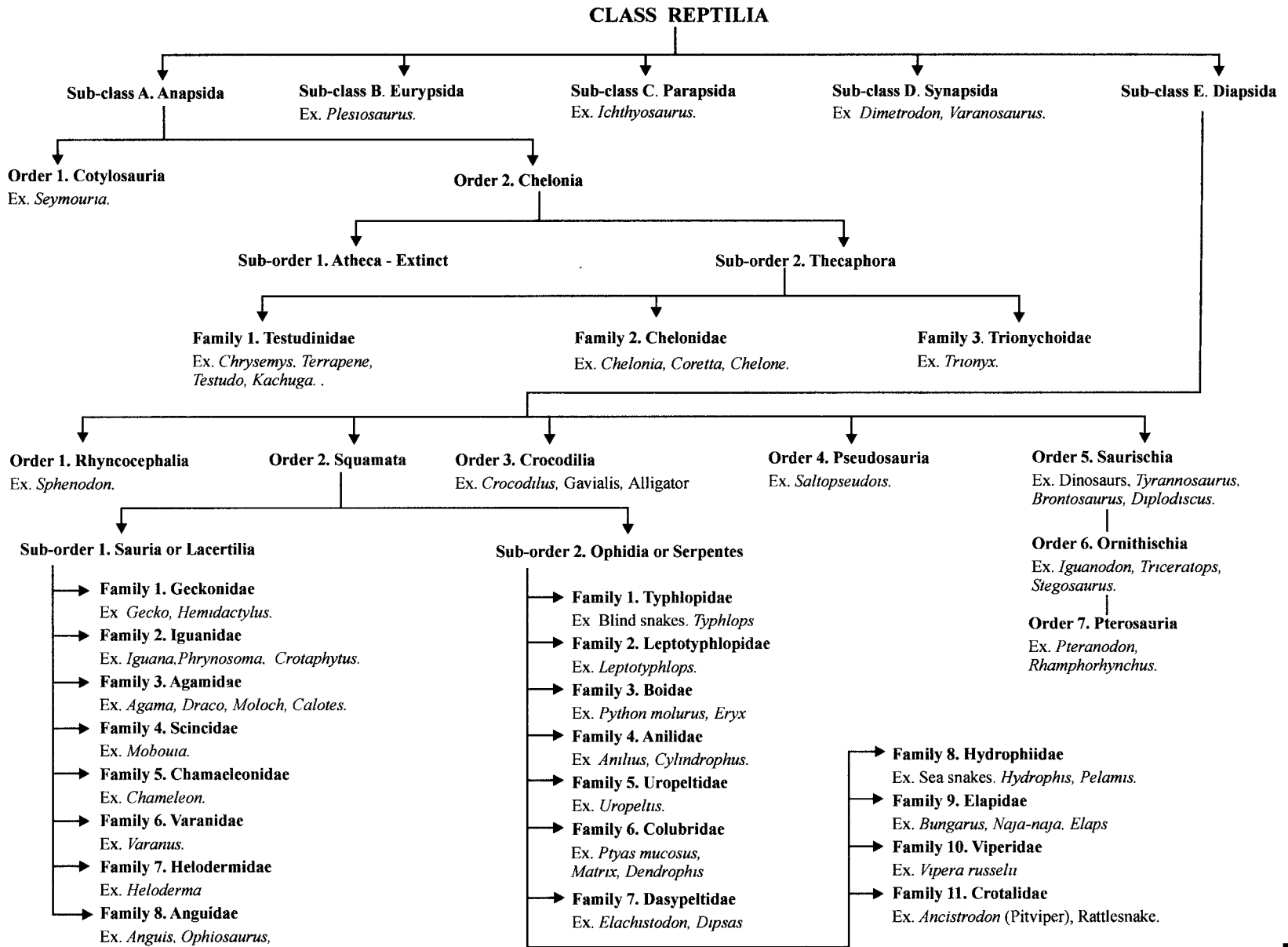

## 74. *Testudo* : Giant Turtle

### Classification :

Phylum.....	Chordata	→	Dorsal tubular nerve cord, notochord and gill-slits present.
Group.....	Craniata	→	Definite head. Cranium with brain present.
Subphylum.....	Vertebrata	→	Vertebral column present.
Division.....	Gnathostomata	→	Jaws and paired appendages present.
Superclass.....	Tetrapoda	→	Paired limbs, lungs, cornified skin and bony skeleton.
Class.....	Reptilia	→	Scaly vertebrates. Right and left aortic arches present. Single condyle. Pulmonary respiration. Embryo with amnion and allantois.
Subclass.....	Anapsida	→	Primitive reptiles. Skull completely roofed over.
Order.....	Chelonia	→	Turtles, tortoises and terrapins.
Suborder.....	Thecophora	→	Thoracic vertebrae and ribs fused to carapace.
Family.....	Testudinidae	→	Toes not webbed, hindlegs cylindrical, shell high.
Genus.....	<i>Testudo</i>		

**Geographical distribution :** *Testudo* is widely distributed in Galapagos Islands, Africa, Europe, India and Sri Lanka. Jurassic to Recent.

**Habit and habitat :** *Testudo* is found in fresh-water or salt water or on land. It feeds on small worms and insects. It also **hibernates** during winter season.

### Comments :

- (1) Commonly known as **Giant turtle**. Body divided into **head, neck, trunk and tail**.
- (2) Body is encased in an oval shell consisting of closely sutured **plate-like bones** in definite manner. Over the shell is a layer of **leathery skin** or cornified scutes also in definite pattern. Dorsal convex portion or carapace and the flatter **ventral portion** or **plastron** are joined on sides by skin.
- (3) **Head**, mounted on **retractile neck, tail**, and limbs protrude between two parts of the shell and in most species can be withdrawn completely within the margins of the shell. Head contains **mouth, nostril** and **eyes**. Behind eye is **external ear opening**.
- (4) **Jaws** lack teeth but bear stout cornified sheaths to crush their food. Quadrate immovable.
- (5) Thoracic vertebrae and ribs consolidated with bony carapace.
- (6) **Feet** are **stumpy**. **Toes** end in **horny claws** that are useful in crawling and **digging**.
- (7) They are **uricotelic**.
- (8) Male has an **erectile penis** on the ventral wall of the cloaca.
- (9) **Oviparous**.

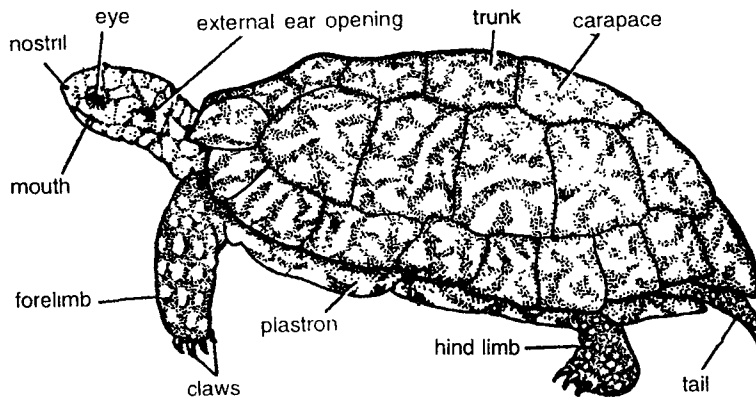

Fig. 74. *Testudo*.

**Special features :** The feet are adapted for walking on land. The limbs are massively built with sprawling gait. The clawed digits contain only two phalanges. Eggs are laid in holes (nests) in ground, dug and covered by females. **Toes not webbed.**

**Identification :** Since this tortoise contains polygonal scales and above features, hence it is *Testudo*.

## 75. *Chrysemys* : Painted Terrapin

**Classification :** Same as that of *Testudo*.

Genus..... *Chrysemys*

**Geographical distribution :** *Chrysemys* is commonly found in India, Sri Lanka, U.S.A., Galapago Islands, Europe, Asia, and Africa, except Australian region. Eocene to Recent.

**Habit and habitat :** *Chrysemys* is a common fresh-water form, but is adapted for **amphibious** life. It feeds on insects, worms and other animals.

**Comments :**

- (1) Commonly called as **painted terrapin**. Body divided into **head, neck, trunk and stumpy tail**.
- (2) Body encased in a bony armour of dorsal **carapace** and ventral **plastron**. Nuchal shield is elongated and narrow. Keel absent.
- (3) **Plastron** is provided with transverse hinge.
- (4) **Costal and neural plates** of carapace convex and dome-shaped.
- (5) **Marginal plates** communicate with the plastron.
- (6) **Head** is triangular containing **eyes, mouth, nares and tympanum**.
- (7) There is a fold of skin behind the head in the neck region.
- (8) **Forelimbs** and **backwardly** directed hind limbs well developed. Middle front toe with 3 phalanges. Toes partly webbed.
- (9) Temporal vacuities are absent.
- (10) Neck, limbs and tail contain beautiful and brilliant coloured stripes. Head, tail and limbs can be completely withdrawn within two shells for safety.

**Identification :** Since this terrapin contains webbed toes and above features, hence it is *Chrysemys*.

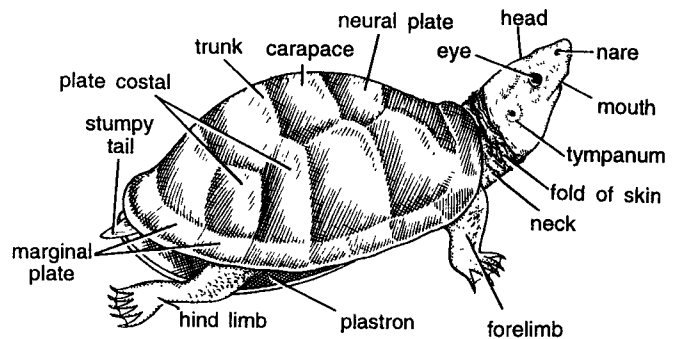

Fig. 75. *Chrysemys*.

## 76. *Kachuga tactum* : Roofed Terrapin

**Classification :** Same as that of *Testudo*.

Genus..... *Kachuga*

Species..... *tactum*

**Geographical distribution :** *Kachuga* is distributed in Indian rivers, specially Ganges. Eocene to Recent.

**Habit and habitat :** *Kachuga* is commonly found in rivers. They concentrate especially at bathing places and also at places where dead bodies are disposed in water. Their food consists of both plants and animals.

**Comments :**

- (1) Commonly called as **tortoise**.
- (2) It is an **armoured** reptile showing gradation between terrestrial and aquatic extremes.

- (3) Head contains mouth, eyes and nares.
- (4) Body is encased in **carapace-plastron box**. Body divided into **head, neck, trunk and tail**.
- (5) First three **neural plates** of the **carapace** are produced into backwardly directed **neural plate spines**.
- (6) Outer surface consists of leathery skin.
- (7) **Head, tail and limbs** can be completely withdrawn within carapace and plastron. Head contains mouth, nostril and eyes.
- (8) It contains several **crests** and is brightly coloured. **Eyes** are provided with eyelids and nictitating membrane.
- (9) Limbs terminate into clawed and webbed digits. Tail **stumpy**.

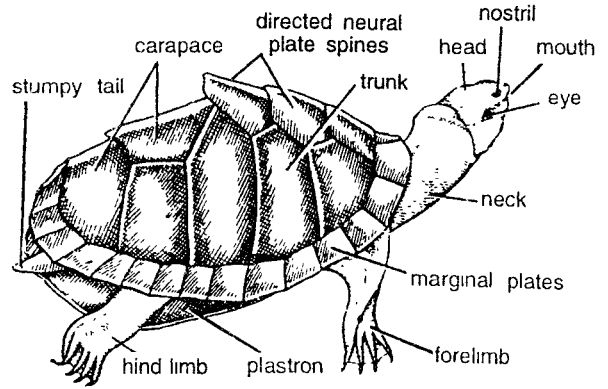
Fig. 76. *Kachuga*.

**Identification :** Since this tortoise contains dorsal spines and above features, hence it is *Kachuga tatum*.

## 77. *Chelone* : Green Turtle

**Classification :** Same as in *Testudo* (upto Order).

Family..... Cheloniidae → Limbs flipper like.

Genus..... *Chelone*

**Geographical distribution :** *Chelone* is distributed in tropical and sub-tropical regions and chiefly found in the Indian, Pacific and Atlantic Oceans and coasts of the United States. Upper Cretaceous to Recent.

**Habit and habitat :** *Chelone mydas* is a marine reptile. They come ashore only to lay eggs.

**Comments :**

- (1) Commonly called as **green turtle**. It measures about 110 cms. **Body** divided into **head, neck, trunk and tail**.
- (2) Body case is rigid. **Carapace** flat, heart-shaped and covered with smooth **bony shields**.
- (3) **Plastron** is joined to carapace by ligament.

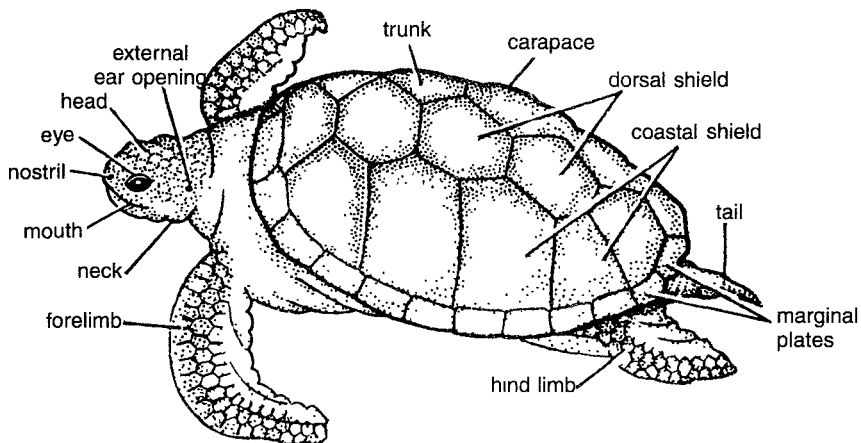
Fig. 77. *Chelone*.

- (4) **Dorsal shields** are juxtaposed fitting closely into each other. **Costal shields** 4 pairs.
- (5) **Head** is covered by single pair of **prefrontal shields**. Jaws contain denticulate edges. Head is partially retractile into shell. Head contains mouth, nostril, eye.
- (6) **Eyes** well developed, provided with eyelids and nictitating membrane.
- (7) **Limbs** adapted for swimming and **flipper like**. The forelimbs form wing-like paddles. Only first digit is clawed while hind limbs clawed and webbed.

**Special features** : The sea turtles are **economically important**, because their armour is utilized for various purposes and their flesh is edible, being very delicious. *Chelone* weighs about 90 kg and is much valued for food.

**Identification** : Since this turtle has flipper-like limbs and above features, hence it is *Chelone*.

## 78. *Trionyx* : Soft River Terrapin

**Classification** : Same as in *Testudo*.

Family..... *Trionychoidae* → Soft shelled turtles.

Genus..... *Trionyx*

**Geographical distribution** : *Trionyx* is widely distributed in India, North America, Africa, Asia and Malayasia Archipelago. Cretaceous to Recent.

**Habit and habitat** : *Trionyx gangeticum* is a common fresh-water and pond terrapin.

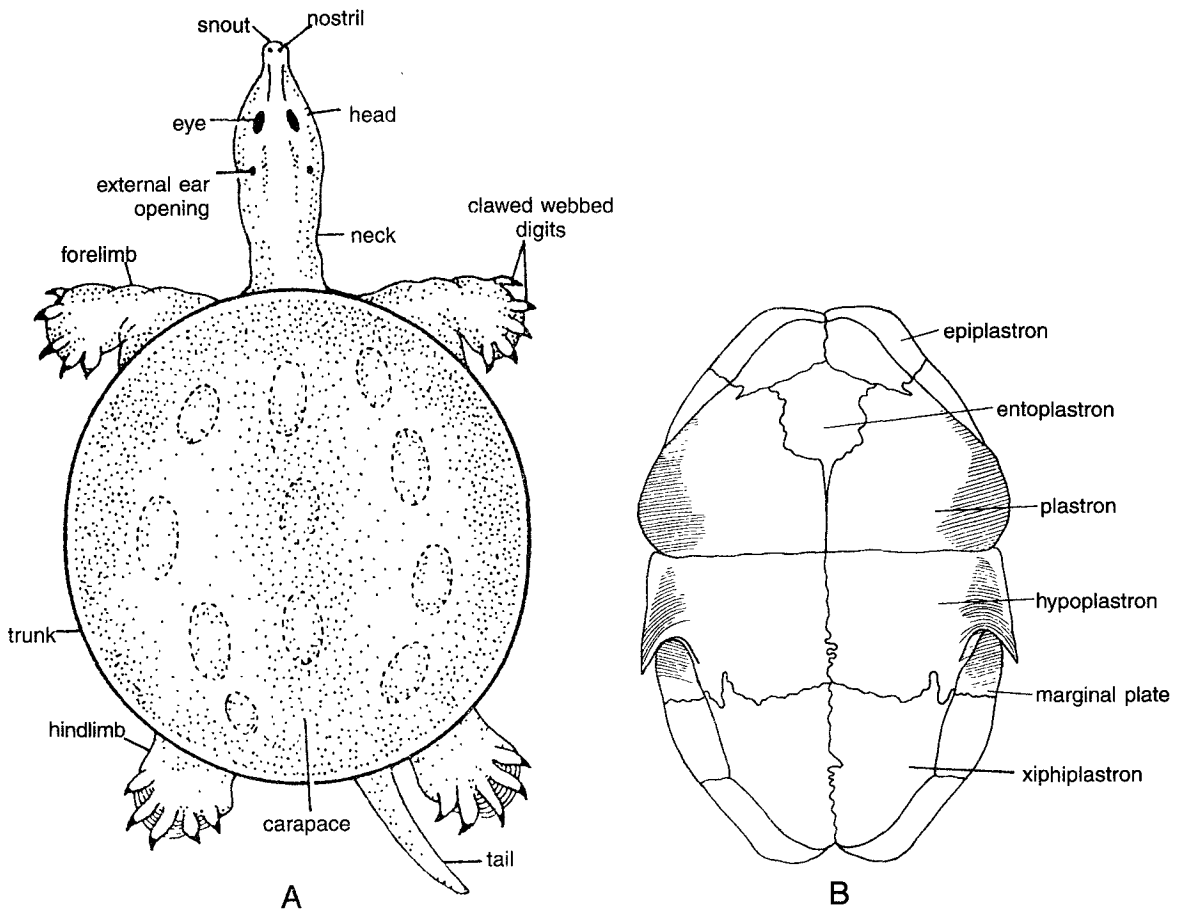

Fig. 78. *Trionyx* : A. Dorsal view. B. Ventral view of plastron turned to one side.

**Comments :**

- (1) Commonly called as **torto** or **soft river terrapin**.
- (2) Body is flat, oval and encased in bony shell. Skin is smooth and leathery. Body divided into **head, neck, trunk and tail**.
- (3) **Head** is pointed with greenish or blackish longitudinal streaks. Lips are fleshy.
- (4) Head contains, **eyes, mouth and nostrils**. Behind eyes are **external ear opening**.
- (5) Dorsal surface is olive above and yellowish below.
- (6) **Carapace** is fused with vertebral column and ribs. Carapace consists of 9 median vertebral plates corresponding to trunk vertebrae and fused with the flattened neural spines of corresponding vertebrae. To these a median nuchal and 2 precaudals are added.
- (7) Lateral parts of carapace are composed of **8 costal plates**. **Marginal plates** are added to costal and precaudals.
- (8) Plastron best seen in inner surface consists of a pair of **epiplastron**, a median **entoplastron** and paired hyo, hypo and **xiphiplastron**.
- (9) Only **neck and tail** vertebrae are **movable**. **Feet** are broadly **webbed** and only three inner digits are clawed.

**Special features :** *Oviparous*. Eggs are laid outside water. Because of rigid shell the breathing movements are produced by protrusion of the head, movements of girdles, limbs and pumping action of hyoid.

**Identification :** Since this terrapin contains clawed digits, webbed feet and longitudinal streaks over head and above features, hence it is *Trionyx*.

## 79. *Sphenodon* : Tuatara

**Classification :**

Phylum.....	Chordata	→	Dorsal tubular nerve cord, notochord and gill-slits present.
Group.....	Craniata	→	Definite head, cranium with brain present.
Subphylum.....	Vertebrata	→	Vertebral column present.
Division.....	Gnathostomata	→	Jaws and paired appendages present.
Superclass.....	Tetrapoda	→	Paired limbs, lungs, confined skin and bony skeleton.
Class.....	Reptilia	→	Scaly vertebrates. Right and left aortic arches. Single condyle. Pulmonary respiration. Embryo with amnion and allantois.
Sub-class.....	Diapsida	→	Skull with two temporal openings separated by post-orbital and squamosal.
Order.....	Rhynchocephalia	→	Living fossil, lizard-like, Ribs single headed and with uncinat processes. Vertebrae amphicentrous.
Genus.....	<i>Sphenodon</i>		
Species.....	<i>punctatum</i>		

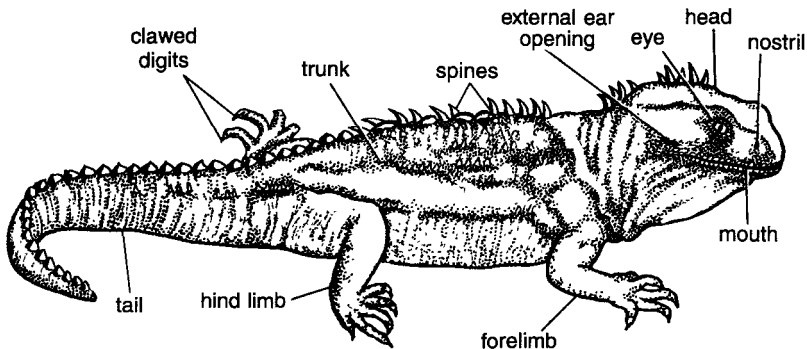

Fig. 79. *Sphenodon*.

**Geographical distribution :** *Sphenodon* is found in New Zealand and specially in the islets of Bay of Plenty. Permian to Eocene and Recent.

**Habit and habitat :** *Sphenodon* lives in burrows, leads semiaquatic life. It is **nocturnal** and eats insects, molluscs or small invertebrates. It also produces frog-like croak. Breeding season November to February.

**Comments :**

- (1) Commonly called as **tuatara**.
- (2) Animal is lizard-like having dull olive-green colour with white and yellow spots and measuring about 75 cm. Body divided into **head, neck, trunk and tail**. Head contains **eye, nostril and mouth**.
- (3) It contains scaly skin and long tail.
- (4) Forelimbs and hind limbs adapted for walking having clawed digits.
- (5) Several backwardly directed hook or crest like spines extend all along mid-dorsal line.
- (6) Skull contains two complete **fossae, quadrate** is fixed, postfrontals are separate (only in *Sphenodon*) and upper jaw has beaks. Teeth acrodont. Mandibles joined by ligament. Between skull and atlas is proatlas. Sternum present and vertebrae amphicoelous. Caudal vertebrae have chevron bones.
- (7) Eye is photosensitive.
- (8) **Anal opening transverse**. Male without copulatory organ. About 10 eggs with hard white shell are laid in holes in the ground. Eggs require 13 months to hatch.

**Special features :** *Sphenodon punctatum* is an important **living fossil**. It has survived from permian and is fast approaching towards extinction. It is protected by law. The tuatara contains several primitive features, such as two **temporal fossae, amphicentrous vertebrae, pineal eye**, uncinata processes in the rib, vomerine teeth in young, horny beak on upper jaw and absence of copulatory apparatus in males. Tuatara is close to the type from where all diapsid reptiles might have originated.

**Identification :** Since this reptile has rows of spines on the back and above features, hence it is *Sphenodon*.

## 80. *Hemidactylus* : Common House Lizard

**Classification :**

Phylum.....	Chordata	→	Dorsal tubular nerve cord, notochord and gill-slits present.
Group.....	Craniata	→	Definite head, cranium with brain present.
Subphylum.....	Vertebrata	→	Vertebral column present.
Division.....	Gnathostomata	→	Jaws and paired appendages present.
Superclass.....	Tetrapoda	→	Paired limbs, lungs, cornified skin and bony skeleton.
Class.....	Reptilia	→	Scaly vertebrates with right and left aortic arches. Single condyle, pulmonary respiration. Embryo with amnion and allantois.
Sub-class.....	Diapsida	→	Skull with two temporal openings separated by postorbital and squamosal.
Order.....	Squamata	→	Lizards and snakes with horny epidermal scales or shields. Quadrate bone movable. Vertebrae procoelous. Anal opening transverse.
Sub-order.....	Sauria or Lacertilia	→	Lizards. Body slender, limbs 4. Pterygoid in contact with quadrate. Eyelids movable.
Family.....	Gecknoidae	→	Toes provided with adhesive pads.
Genus.....	<i>Hemidactylus</i>		

**Geographical distribution :** *Hemidactylus* has world-wide distribution and is chiefly found in India, Europe, Asia, Africa, United States of America, Sri Lanka and China.

**Habit and habitat :** *Hemidactylus* is a common house lizard found in every home. **Nocturnal** in habit. During winter they **hibernate** under wood, logs and crevices of the walls. They are adapted to walk on walls. They feed on insects and small invertebrates. It is a fast runner diapsid.

**Comments :**

- (1) Commonly known as **wall lizard**.
- (2) Body measuring approximately 25 cm in length is slender, covered with minute small scales and divided into **head, neck, trunk and tail**.



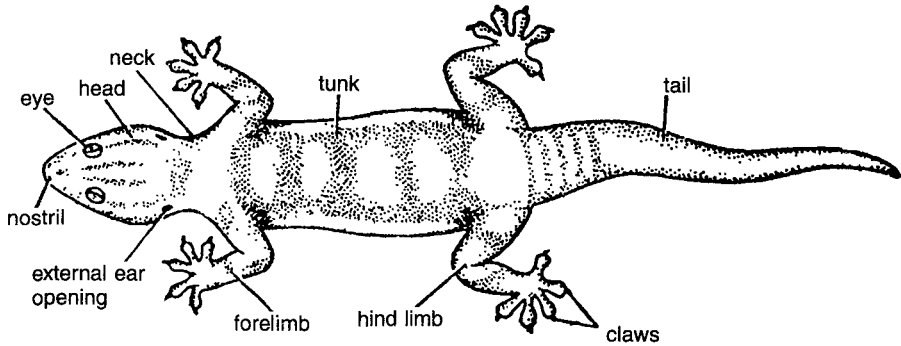

Fig. 80. *Hemidactylus*.

- (3) They are ugly looking. Some members contain **black and dark grey patches** on dorsal surface while others have dark grey dorsal surface. **Abdomen is yellowish white.**
- (4) Head is triangular containing **eyes, nostrils and external ear opening.** **Eyes lack movable eyelids. Tongue protrusible.**
- (5) Forelimbs and hind limbs well developed. **Toes are provided with rounded adhesive pads** for climbing.
- (6) Many wall lizards **produce sound.**
- (7) Quadrate bone movable. Only **supratemporal arch** present.
- (8) Vertebrae **amphicoelous.** Egg shells **calcified.**

**Special features :** The tail if broken from any place it again **regenerates**, although small in size because vertebrae do not regenerate. Tail contains intervening unossified zones between vertebrae which are easily broken and then regenerated. This is called as **caudal autotomy**. Wall lizard is adapted to walk on walls, roofs and on smooth surfaces. The walking is effected by the dilated digits, which contain double series of lamellae and work under vacuum principle. The digits are first pressed over wall and then released gently to create a vacuum, by which they remain adhered to wall and are able to walk.

**Identification :** Wall lizard or *Hemidactylus* is well familiar even to a lay-man and can easily be identified by above features.

## 81. *Gecko* : Wall Lizard

**Classification :** Same as that of *Hemidactylus*.

Genus..... *Gecko*

**Geographical distribution :** *Gecko* has cosmopolitan distribution but is specially found in Asian and European countries.

**Habit and habitat :** Same as those of *Hemidactylus*.

**Comments :**

- (1) *Gecko* has similarity in appearance with *Hemidactylus* and is also commonly called as **house Gecko** or wall lizard.
- (2) Body is divided into **head, neck, trunk and tail.**
- (3) Head is small, trunk and tail are elongated. **Head** contains **nostrils and eyes.**
- (4) Behind eyes is **tympanum** with opening for external ear.
- (5) Forelimbs and hind limbs are adapted for **walking on walls** and smooth surfaces.
- (6) Digits of **fore and hind limbs** are clawed and contain **vertical lamellae** functioning as **adhesive pads.**
- (7) Tail regenerates if broken.

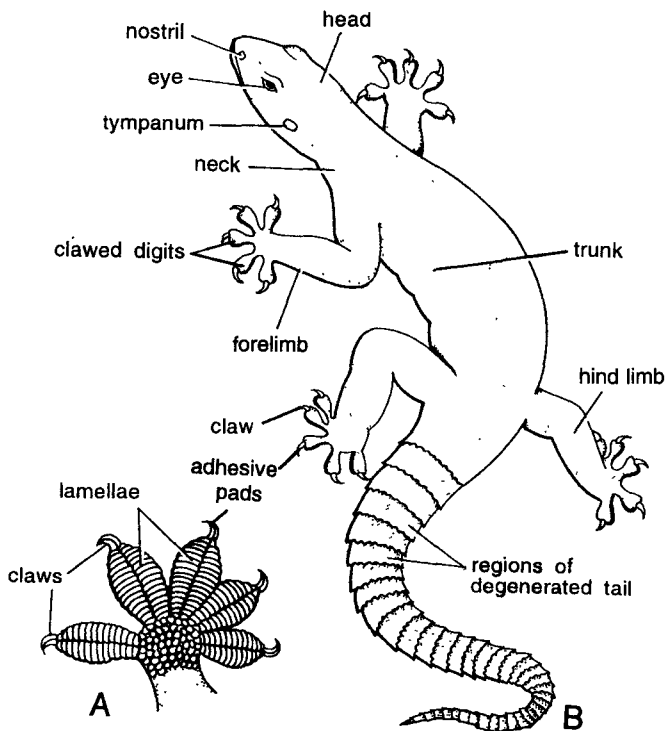

Fig. 81. *Gecko*. A. Adhesive pad, B. Adult.

**Special features :** Geckos emit a peculiar little yapping bark when disturbed.

**Identification :** Since the animal contains small head, long tail and above features, hence it is *Gecko*.

## 82. *Phrynosoma* : Horned Toad

**Classification :** Same as that of *Hemidactylus*.

Family.....Iguanidae → Limbs normal. Teeth homodont.

Genus.....*Phrynosoma*

**Geographical distribution :** *Phrynosoma* is a New World lizard and is chiefly found in Eastern Washington, Kansas to California and Mexico.

**Habit and habitat :** *Phrynosoma* is well adapted for desert life. It lives on dry ground and sandy places. It can live without water for a long time. It feeds on ants and other small insects. In the sunlight it feels happy but as night approaches it burries itself in the sand keeping only the head and horns exposed.

**Comments :**

- (1) Commonly known as **Horned toad**.
- (2) Body broad, flat and spiny. Scales of head region are enlarged like horns while regular **spiny scales** are found all over the body. Body divided into **head, neck, trunk and tail**.
- (3) Dorsal surface is yellowish grey. 2 pairs of large spines are found on each sub-lateral position and number of runs of small spines present over the trunk. Small and large spines present on the tail. Spines also present on **forelimbs** and **hind limbs**. Digits are clawed for digging sand.
- (4) Undersurface of thigh contains pores in both sexes and is covered with keeled scales.

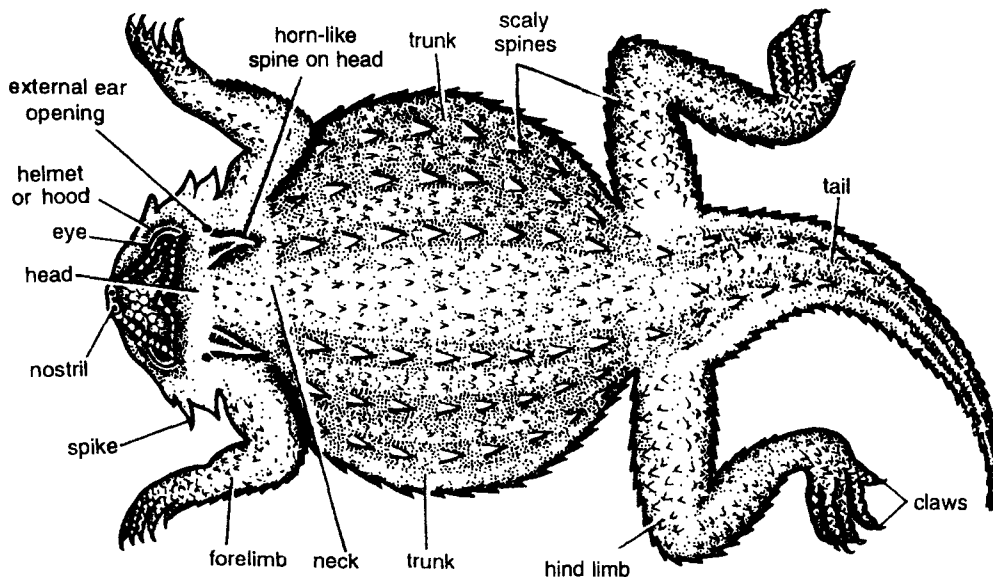

Fig. 82. *Rhynosoma*.

- (5) **Head** contains 5 spikes on each side, one post-orbital, three temporal and one occipital. Head contains eyes, nostril and prominent **helmet**. A pair of barn-like process are present just below helmet.
- (6) The sides of the lower jaw project in the shape of prominent ledges and are protected by a series of **small spines**.
- (7) **Tongue** is fleshy and **non-protrusible**. Eyelids are complete. Teeth are usually homodont or pleurodont. Vertebrae **opisthocelous**.
- (8) Nostrils are provided with valves, which prevent sand to enter into nostrils. External ear **opening** present near born like spine.
- (9) Tail is short.

**Special features :** *Phrynosoma* is well adapted for arid zone living. When disturbed, the lizard squirts a tiny stream of blood from the eye which can go upto a distance of two feet and thus it protects itself.

**Identification :** Since the animal contains rough skin, spines all over the body and above features, hence it is *Phrynosoma*.

### 83. *Iguana*

**Classification :** Same as that of *Phrynosoma*.

Genus..... *Iguana*

**Geographical distribution :** *Iguana* is found in tropical countries. It is distributed in Mexico, West Indies, Southern and Central America.

**Habit and habitat :** *Iguana* is adapted for **active running** and **climbing**. It feeds on leaves, fruits, some insects and small vertebrates. It lives on trees.

**Comments :**

- (1) Lizard measures about 2 metres having head short neck, compressed **trunk** and **elongated tail**.
- (2) General colour of upper part is a mixture of green and black and underpart pale greenish or whitish.
- (3) Back contains lance-like spines along mid-dorsal line extending upto tail. Mid-line spines are also present along lower jaw flap of skin.

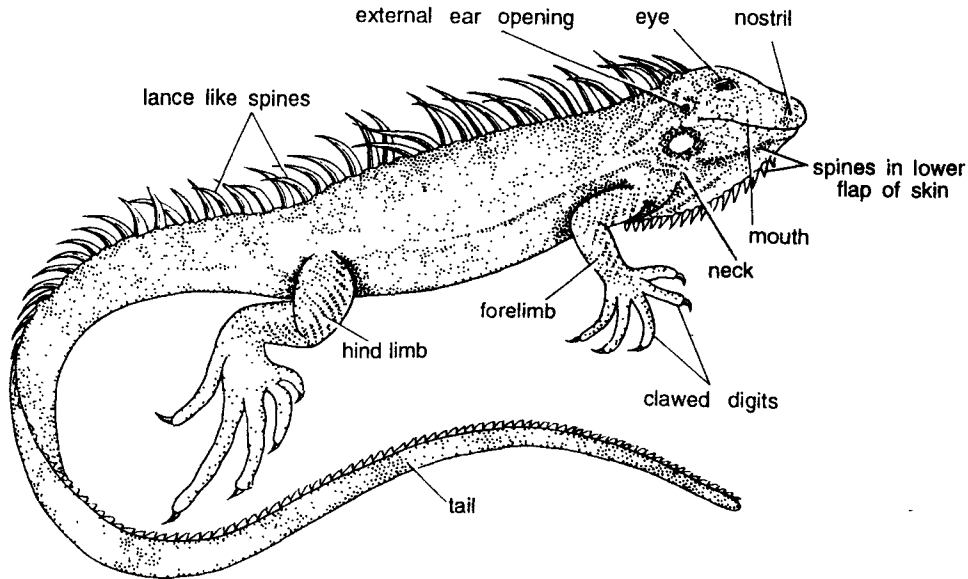
Fig. 83. *Iguana*.

- (4) Head contains wide **mouth**, **small eyes**, **nostrils** and opening of external ear. Teeth are **acrodont like** and fixed to the sides of the jaw. Eyelids complete. Tongue is fleshy and non-protractile.
- (5) Forelimbs and hind limbs are normal. Digits are **clawed**.
- (6) Both sexes have femoral pores.
- (7) In tropics *Iguana* is used as food by man.

**Identification :** Since this lizard contains median row of spines on back and tail, besides above characters, hence it is *Iguana*.

### 84. *Crotaphytus* : Collared Lizard

**Classification :** Same as that of *Phrynosoma*.

Genus.....*Crotaphytus*

**Geographical distribution :** *Crotaphytus* is widely distributed in West Indies, Mexico, Southern and Central America.

**Habit and habitat :** *Crotaphytus* is a land lizard **adapted for fast running** and can jump like frog. It is **nocturnal, carnivorous, oviparous** and capable of **changing colours**.

**Comments :**

- (1) Commonly called as **collared** or **inflated** lizard.
- (2) Body divided into **head, neck, trunk** and **tail**.
- (3) **Head** small containing **mouth, eyes, nares** and **tympanum**. **Eyes** have movable eyelids. Tongue is small. Teeth pleurodont.
- (4) **Neck** is small and in male possesses a double black collar and female has a slaty grey narrow **collar**.
- (5) **Forelimbs** and **hind limbs** are stout, **clawed** and elongated.
- (6) Vertebrae **procoelous**
- (7) Tail is elongated and narrowly pointed.

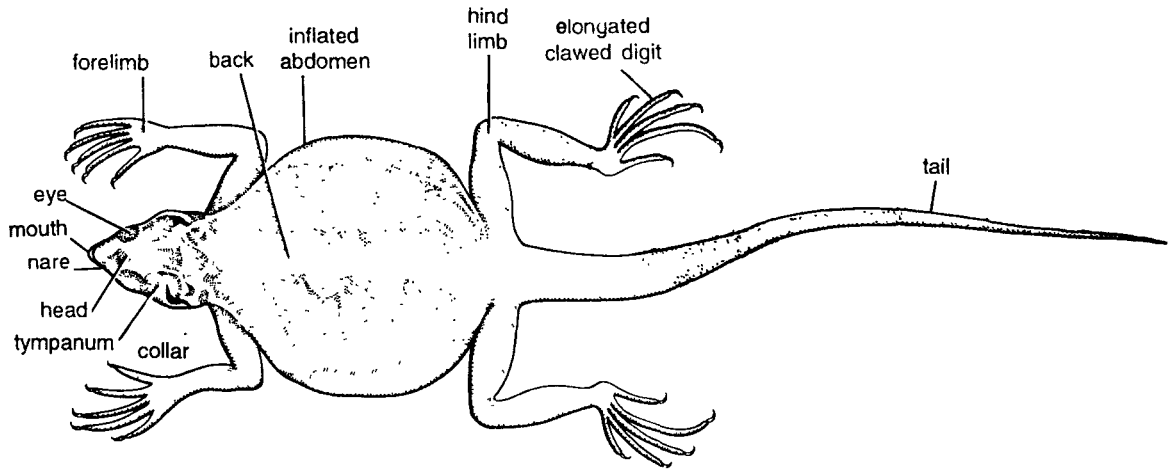

Fig. 84. *Crotaphytus*.

**Special features :** The lizard shows brilliant pigmentation specially during breeding season. The abdomen is inflated. The male is bright green coloured and the body surface is adorned with yellow spots. Females are grey coloured. The tail breaks in danger *i.e.*, it shows autotomy.

**Identification :** Since the animal contains collar, inflated abdomen and above features, hence it is *Crotaphytus*.

### 85. *Draco* : Flying Lizard

**Classification :** Same as in *Hemidactylus* (upto Sub-order).

Family.....*Agamidae* → limbs normal. Teeth differentiated.

Genus.....*Draco*

**Geographical distribution :** *Draco* is commonly distributed in Myanmar, India, Malayasia, Europe, Africa, Asia and Australia.

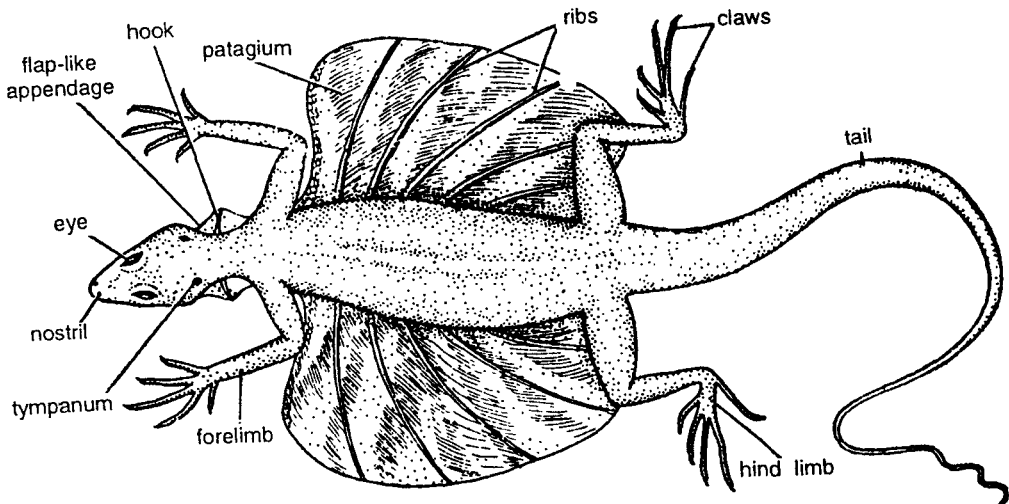

Fig. 85. *Draco*.

**Habit and habitat :** *Draco* is arboreal, living on trees. It feeds on small insects.

**Comments :**

- (1) Commonly known as **flying dragon** or **flying lizard**.
- (2) Body is dorsoventrally compressed, measuring 15 to 22 cm in length and divided into **head, neck, trunk and tail**.
- (3) Head is more or less triangular and contains **eyes, tympanum** behind eyes and **nostril**. Eyes are small with eyelids. Teeth **heterodont** and attached to the edges of the jaws.
- (4) Tongue is thick and short. Some animals have thoracic sac or dorsal spine.
- (5) Neck contains **three hooks** forming flap like appendages. Below the neck there are sac-like structures known as **gular pouches**, which are larger in males than females and they help in copulation.
- (6) Forelimbs and hind limbs normal.
- (7) On both sides of the body **wing** or **patagium** formed by extension of skin is present. Patagium is supported by lateral ribs.
- (8) **Tail** long, slender and whip-like.

**Special features :** *Draco* shows extreme adaptation for **flying life** and thus avoids its enemies on the ground. Most significant structures are membranous wings or **patagia**, which to volplane from a height. Flying lizard is adapted for climbing and gliding from higher to lower branches. *Draco* is brilliantly and beautifully coloured like flowers of trees in which it lives and thus it shows **camouflage (mimicry)**.

**Identification :** Since this lizard contains patagium and above features, hence it is *Draco*.

## 86. *Moloch*

**Classification :** Same as that of *Draco*.

Genus..... *Moloch*

**Geographical distribution :** *Moloch* is found in Australia.

**Habit and habitat :** *Moloch* is also adapted for dry condition and it is an **ant-eater**.

**Comments :**

- (1) Body divided into **head, neck, trunk and tail**.
- (2) Skin is rough and highly **hygroscopic** which absorbs moisture from the atmosphere.
- (3) Body of the animal is elongated and is adorned with heavy armour of scaly spines. There are two horn like spines on head. Spines cover the body on all sides. **Trunk spines** are thicker. Tail spines and limb spines are smaller in size.
- (4) **Head** contains small **mouth** and **nostrils** and **eyes**.
- (5) **Eyes** well developed with eyelids and rounded pupil.
- (6) **Lateral teeth** of the upper jaw are implanted horizontally and directed inwards.
- (7) Homodont teeth attached to edges of jaws (acrodont). Tongue is thick and short.

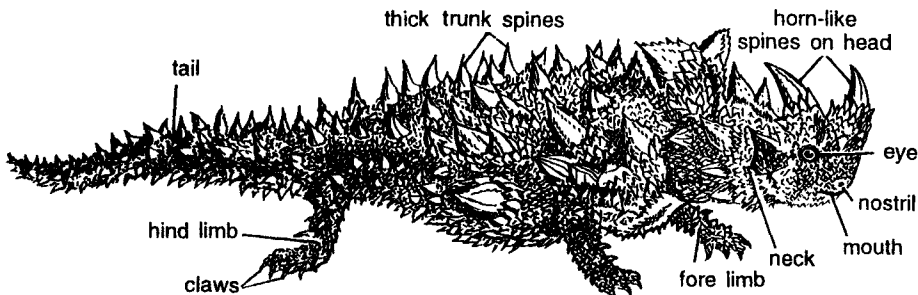

Fig. 86. *Moloch*.

- (8) **Limbs** are normal, **pentadactyl**. **Forelimbs** and hind limbs have **claws** in digits. Both the limbs contain spines.

**Identification** : Since this lizard contains characteristic spines and all above features, hence it is *Moloch*.

### 87. *Calotes* : Garden Lizard

**Classification** : Same as that of *Draco*.

Genus..... *Calotes*

**Geographical distribution** : *Calotes* is found in India, Malayasia and China.

**Habit and habitat** : *Calotes* is adapted for **arboreal life** and slight disturbance or any noise causes the lizard to run away swiftly. It feeds on small insects.

**Comments** :

- (1) Commonly known as **blood sucker** because of the red colour of neck. Its common name in Hindi is **girgitan** or **girgit**.
- (2) **Body** is **elongated**, slender, 30 cm in length, **covered** with **tough scales**, and divided into **head**, **short neck**, **trunk** and **tail**.
- (3) Animal contains a **crest** of spines in mid-dorsal line. Spines also present on under surface of head and neck.
- (4) Head contains, mouth, eyes, nostrils and small opening for external ear.
- (5) **Tongue short**.
- (6) Teeth usually differentiated (**heterodont**) and attached to the edges of jaws (acrodont).
- (7) **Forelimbs** and **hind limbs** normal. **Tail** elongated and does not break.

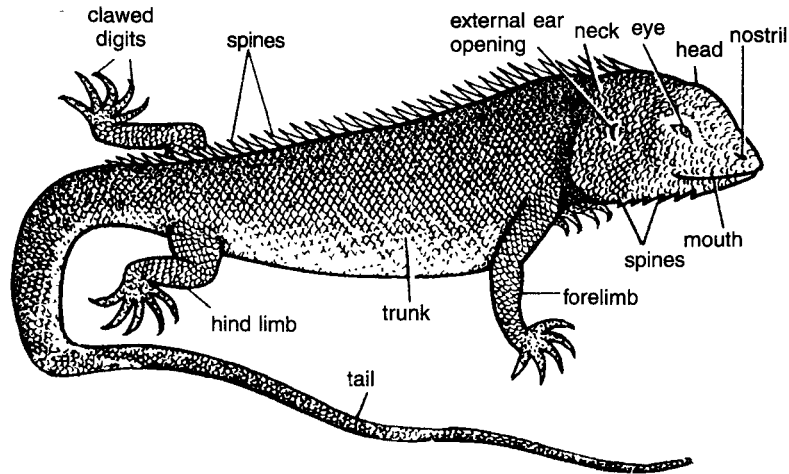

Fig. 87. *Calotes*.

**Special features** : *Calotes* is also famous for **colour changes**. The original colour is olive green but during courtship, colour changes to yellow and head becomes red. The colour changes are largely governed by temperature and environment and also by hormones from pituitary. The colour pigments are present in skin. During breeding season, male acquires brilliant colours and a gular pouch also develops in neck. The male changes colour during courtship and fights for female. Viviparous.

**Identification** : Since the animal contains back spines, long pointed tail and above features, hence it is *Calotes*.

### 88. *Mabuia* : Skink

**Classification** : Same as in *Hemidactylus* (upto Sub-order).

Family..... *Scincidae* → Scales smooth.

Genus..... *Mabuia*

**Geographical distribution** : *Mabuia* is commonly found in India, Myanmar, Bangladesh and China.

**Habit and habitat** : *Mabuia* is adapted for **burrowing** life and consequently head contains small eyes.

**Comments :**

- (1) Commonly called as **Skink or Sanp ki mosi**.
- (2) It is, at first look, mistaken for small snakes.
- (3) Body is reddish-brown in colour, vermiform, and divided into **head, neck, trunk and tail**.
- (4) **Body is covered** with smooth and round margined **cycloid scales** with dermal ossifications beneath.
- (5) Head has **sub-cutaneous eyes**. Tongue with scale-like **papillae** and **indentate tip**.
- (6) Forelimbs and hind limbs have delicate toes.

**Special features :** This **diapsid lizard** shows **retrogressive convergent evolution**.

**Identification :** Since this reptile is reddish in colour, vermiform and has all above features, hence it is **Mabuia**.

**89. Chamaeleon**

**Classification :** Same as in *Hemidactylus* (upto Sub-order).

Family..... *Chamaeleonidae* → Changes colour. Tail prehensile.

Genus..... *Chamaeleon*

**Geographical distribution :** *Chamaeleon* has world-wide distribution. It is found in Africa, Madagascar, Southern Arabia, Spain, Europe, Asia, Syria, India and Sri Lanka.

**Habit and habitat :** It is **arboreal** and feeds on insects.

**Comments :**

- (1) *Chamaeleon* is the most favourite diapsidan lizard having compressed body covered with scales and divided into **head, neck, trunk and tail**.
- (2) Trunk region occupying most part of the body is slightly bent and contains row of spines or crest along mid-dorsal line.
- (3) **Head** has wide **mouth**, **large eyes**, **small nostrils** and backwardly directed **hood** or **helmet** formed by squamosal and occipital bones. Skull and atlas joined by a proatlas.

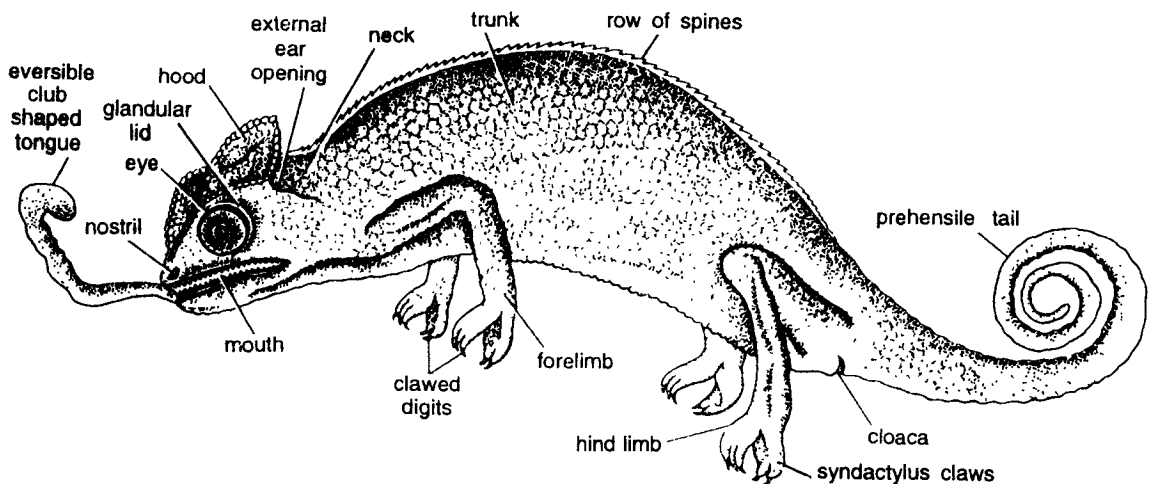

**Fig. 89. Chamaeleon.**

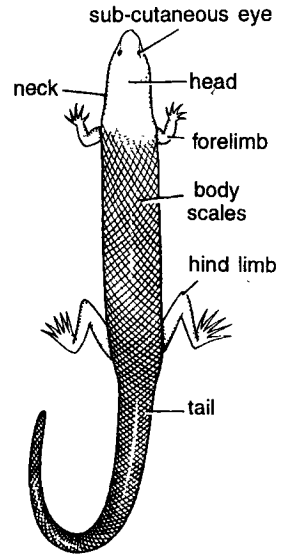

**Fig. 88. Mabuia.**



- (4) **Eyes large** covered with a thick glandular lid pierced by a small central opening for pupil. **Eyes** adapted for **binocular vision**; they work independently while catching insects.
- (5) Tip of **tongue club-shaped** and mucus-coated. Tongue **projectile** and can be shot several inches beyond head to catch insect or prey.
- (6) Acrodont teeth are found on maxillaries and mandible. Premaxillaries and palate without teeth.
- (7) Both **forelimbs** and **hind limbs** well developed. The claws are **syndactylus** in which digits are found in groups. The toes are **opposed** (2 versus 3) for **grasping** branches of trees.
- (8) **Tail prehensile** and meant for coiling round branches of trees. Cloaca is ventrally situated.
- (9) **Lungs** end in several diverticula or air sacs ending in body. Tympanum and tympanic cavity absent. Quadrate immovable and vertebrae procoelous. Jacobson's organs and sensory part of nose absent.

**Special features :** *Chamaeleons* are famous for changing their **colour of the skin** according to the surrounding.

**Identification :** Since this reptile contains hood, syndactyl limbs, prehensile tail and all above features, hence it is *Chamaeleon*.

## 90. *Varanus* : Monitor Lizard

**Classification :** As in *Hemidactylus* (upto Sub-order).

Family.....*Varanidae* → Large trunk. Limbs stout. Tongue bifid.

Genus.....*Varanus*

**Geographical distribution :** *Varanus* is distributed in Africa, Southern Asia, South East islands of Australia, India, Sri Lanka and Malaya. Old world lizard.

**Habit and habitat :** *Varanus* inhabits **dry places** under stones and rocks and leads a **burrowing** life. It is most active at night and feeds upon tortoises, squirrels and dead bodies of other animals. Monitor lizards are **carnivorous** and **semiaquatic**.

**Comments :**

- (1) Commonly known as **Monitor lizard**.
- (2) Animal measuring 60 to 90 cm in length is divided into **head, neck, trunk and tail**.

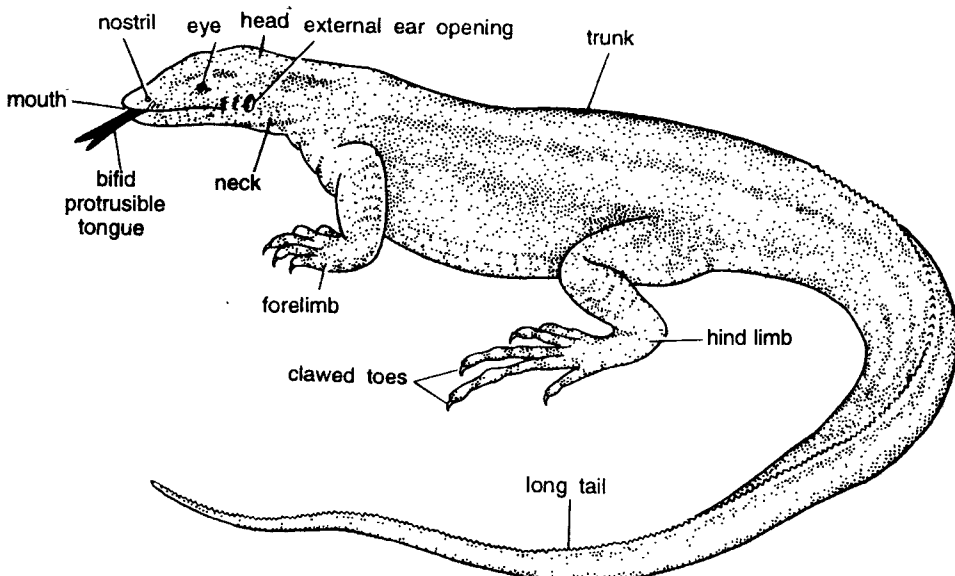

**Fig. 90. *Varanus*.**

- (3) **Body** is covered with smooth, small scales having large brownish, black and orange patches, which act like warning colours.
- (4) **Head** is triangular and contains fixed **eyes**, **nostrils** and **mouth**. External ear opening present just behind head.
- (5) Mouth gap wide with a long **bifid smooth** and **protrusible tongue**. **Teeth** large pointed, pleurodont and dilated at base.
- (6) Osteoderms absent. Post-orbital arch incomplete.
- (7) **Trunk** is large and **stout**. **Tail** is **long thickened** and serves as **storehouse for fat**.
- (8) **Forelimbs** and **hind limbs** are stout, well developed and adapted for swift movement, but they can hardly lift the body up from the ground. Digits are **clawed**.

**Identification** : Since the animal has elongated trunk and tail and above features, hence it is *Varanus*.

## 91. *Heloderma* : Gilla Monster

**Classification** : Same as in *Hemidactylus* (upto Sub-order).

Family..... *Helodermidae* → Poisonous lizard. Fleshy bifid tongue.

Genus..... *Heloderma*

**Geographical distribution** : *Heloderma* is found in deserts of Mexico and U.S.A.

**Habit and habitat** : *Heloderma* lives in dry places under rocks and in burrows. It is a clumsy, sluggish animal which feeds on snake eggs and lizards.

**Comments** :

- (1) Commonly called as **Gilla monster** or **Hella monster**.
- (2) **Body** measuring about 60 cm, is **covered with ugly tubercles** and divided into **head**, **neck**, **trunk** and **tail**.
- (3) **Body** contains black and orange scales forming coloured patches. Dorsal scales are bead-like over bony tubercles (osteoderms). Ventral scales flat.
- (4) **Head** is short, stout having **eyes**, **nostrils** and a **wide mouth**. **External ear opening** present behind eyes.
- (5) **Teeth** **pleurodont**, fang-like and contain labial poison glands which open on outer 'gum' of lower jaw. Tongue is fleshy and bifid.
- (6) **Trunk** and **tail** stout and rounded.
- (7) Forelimbs and hind limbs are short, powerful and well developed. It is capable of swift movement. Digits are clawed.
- (8) *Heloderma* lays eggs in the nest formed in sandy soil.

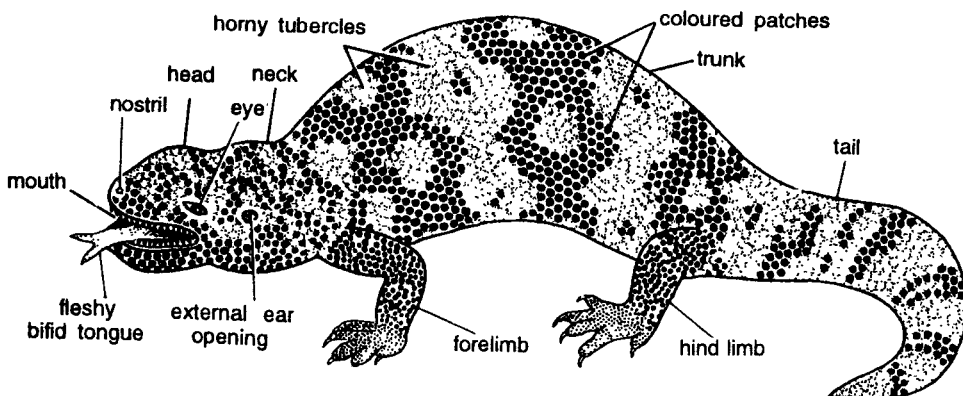

Fig. 91. *Heloderma*.

**Special features :** *Heloderma* is the only **poisonous lizard**. The poison apparatus comprises of a modified sublingual salivary gland that secretes a poisonous fluid. Poison glands open on outer gum of lower jaw. Venom is potent; bite is fatal to small animals, and rarely to man.

**Identification :** Since the lizard has bead-like scales, tubercles, coloured patches, stout trunk and above features, hence it is *Heloderma*.

## 92. *Ophiosaurus* : Glass Snake

**Classification :** Same as in *Hemidactylus* (upto Sub-order).

Family..... *Anguidae* → Limbs absent. Body slender.

Genus..... *Ophiosaurus*

**Geographical distribution :** *Ophiosaurus* is commonly found in U.S.A., Mexico, Africa, Western Asia and India. The Indian species is *O. gracilis* found in the Eastern Himalayas.

**Habit and habitat :** It is a **burrowing** animal.

**Comments :**

- (1) Commonly called as **glass snake**.
- (2) Body is short, snake-like, having greenish brown colouration with longitudinal stripes and divided into **head, trunk and tail**.
- (3) **Head** contains **mouth, nostrils** and **eyes**. The eyes with eyelids are reduced due to burrowing life. Behind eyes are **tympanum**.
- (4) Rest of the body is covered with rectangular epidermal scales arranged in circular and longitudinal rows. Beneath scales, the body plates have hard texture.
- (5) Ventrolateral longitudinal skin folds terminate into two locomotory spikes near cloaca.
- (6) **Limbs are absent**. **Tail** is fragile and breaks more quickly than in any other lizard.

**Special features :** *Ophiosaurus* is distinguished from snakes by a narrow gape of mouth, movable eyelids and tympanic holes and from limbless Amphibia by the presence of epidermal scales and a long tail. A group of American limbless lizards (worm lizards) have head shields, annular bands like earthworms and no scales.

**Identification :** Since the animal is without limbs and has above features, hence it is *Ophiosaurus*.

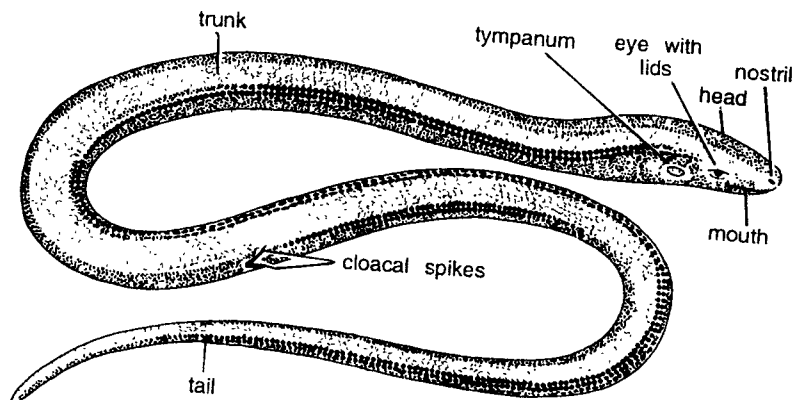

Fig. 92. *Ophiosaurus*.

## SNAKES

Man has always feared and worshipped snakes in India. Snake bites are often fatal in case of poisonous snakes. A detailed account is given below in order to distinguish the poisonous and non-poisonous snakes.

- (1) **Non-poisonous snakes.** Pythons, trinket snakes and racer snakes.
- (2) **Poisonous snakes.** Cobra, Krait, Vipers, Russell's viper, Saw-scaled vipers.

The poisonous snake bites have two types of toxins present in the venom : (i) **Neurotoxins** and (ii) **hemotoxins**. The neurotoxins act on motor nerve cells and provoke muscular paralysis. In case of cobra snake venom, both convulsions and paralysis may occur. The hemotoxins result in **haemorrhages, destruction of tissue cells, red cells**, blood vessels and specific organs. The victim (patient) in both cases has respiratory difficulties and haemorrhages. As the poison is absorbed into the tissues, the patient feels dimness in vision. Pulse rate becomes rapid and weak. Convulsions are sometimes associated with vomiting. *Benadryl* acts as antidote to counteract the effect of hemotoxins, local leisons are applied with *Antisera*. Medicines are injected intravenously.

The snakes are classified on the basis of scales which are of taxonomic importance. Scales also help in distinguishing poisonous and non-poisonous snakes. The snakes contain shields of scales in the head. The identifying shields are named as internasal, nasal, prefrontal, loreal, pre-ocular, frontal supraocular, post-ocular, parietal, mental, occipital, pit, supra-labial and infra-labial. The anterior sublingual and posterior sublingual constitute ventral or lower side of head. In primitive snakes (sandy boa and vipers) the head scales are minute, semicircular and undifferentiated. The dorsal scales are elliptical, rhomboid, tuberculated, serrated and keeled. The following chart is designed to differentiate poisonous and non-poisonous snakes.

### [I] Non-poisonous snakes differentiated on the basis of scales

- (a) Scales on body semi-circular, tail blunt, dorsal and ventral scales undifferentiated. *Typhlops* (Blind snakes)
- (b) Scales on body distinct, ventral scales are found along belly.
- (1) Ventral scales partially cross the belly, eyes present.
  - (i) Rough tail and tail end blunt. *Uropeltis scellatus*
  - (ii) Tail smooth, having blunt end. *Eryx conicus johnii* (Sand boa)
  - (iii) Long tail provided with spurs. *Python molurus*
- (2) Ventral scales completely cross the belly. Head covered with symmetrical plates, hypophyses may or may not be present. Family *Colubridae*

### [II] Poisonous snakes differentiated on the basis of scales

Ventral scales partially or completely cross the belly. Head shields without loreal. Tail cylindrical except in sea snakes. Hypophyses present. Teeth modified to form fangs (Fig. 88).

- (1) Ventral scales partially across the belly. Tail flattened, oar-like. Scales from ventral ridge. Eyes present at anterior end of head. Poison fangs are present. *Hydrophis*
- (2) Ventral scales complete across the belly. Head and tail long. Poison fangs small and naked. Family *Elapidae*
  - (i) Median dorsal scales hexagonal. The colour of the body steel-blue with white bars. *Bungarus caeruleus* (Krait)
  - (ii) The colour of the body yellow with black cross bands and face contains a black stripe. *Bungarus fasciatus*
  - (iii) Hooded snake. Eyes contain round pupil. The dorsal frontal shields truncated. Three small post-ocular scales behind the eyes. Supralabials 7 in number. Caudal scales paired. The hood contains monocellate or binocellate marks and 2-3 series of black band on ventral surface. A triangular shield between 4th and 5th infralabial. *Naja naja* (Cobra)

- (iv) Hooded snake. Frontal shield not truncated. The triangular shield between 4th and 5th infra-labial absent. Two large occipital shields behind parietals. Poison fang present. The hood contains yellow cross stripes dorsally and two black bands ventrally with corner black spots.  
*Naja hanna* (King cobra)
- (v) Hood absent. Post-ocular 2, supra-labial 6. 3rd and 4th supra-labial touching eye. 3-4 teeth behind poison fang. The colour of body light brown or reddish with black stripes or spots over head.  
*Callophis* (Coral snake)
- (3) Ventral scales on the body. Tail elongated. Head triangular and containing minute shields. Poison fangs erectile and sheathed. Eyes contain vertical pupil.  
**Family Viperidae**
- (i) Dorsal scales oblong with median vertical ridge and with 3 rows of elliptical spots on body.  
*Russell's viper*
- (ii) Slide dorsal scales serrated which make continuous sound. Head contains arrow mark. Small snakes. Locomotion by side winding. The poison fangs erectile and sheathed.
- (iii) Between pre-ocular and loreal there is a pit behind nasal opening. Eyes contain vertical pupil. Body scales keeled. Tip of head raised in rostral region. Poison fangs erectile and sheathed.  
*Ancistrodon* (Pit viper)

### 93. *Typhlops* : Blind Snake

#### Classification :

<b>Phylum</b> .....	<b>Chordata</b>	→	Dorsal tubular nerve cord, notochord and gill-slits present.
<b>Group</b> .....	<b>Craniata</b>	→	Definite head. Cranium with brain present.
<b>Subphylum</b> .....	<b>Vertebrata</b>	→	Vertebral column present.
<b>Division</b> .....	<b>Gnathostomata</b>	→	Jaws and paired appendages present.
<b>Superclass</b> .....	<b>Tetrapoda</b>	→	Paired limbs, lungs, cornified skin and bony skeleton.
<b>Class</b> .....	<b>Reptilia</b>	→	Scaly vertebrates with right and left aortic arches. Single condyle. Pulmonary respiration. Embryo with amnion and allantois.
<b>Sub-class</b> .....	<b>Diapsida</b>	→	Skull with two temporal openings separated by postorbital and squamosal.
<b>Order</b> .....	<b>Squamata</b>	→	Lizards and snakes with horny epidermal scales or shields. Quadrate bone movable. Vertebrae procoelous. Anal opening transverse.
<b>Sub-order</b> .....	<b>Ophidia</b>		Snakes. Limbs, feet, ear openings sternum and urinary bladder absent. Mandibles jointed anteriorly by ligament. Tongue slender, bifid and protrusible. Left lung reduced.
<b>Family</b> .....	<b>Typhlopidae</b>	→	Eyes vestigial under opaque scales.
<b>Genus</b> .....	<b><i>Typhlops</i></b> (Blind snake)		

**Geographical distribution :** *Typhlops* is widely distributed in Europe, Asia, Africa, America, Australia, India, tropics and subtropics of both hemispheres.

**Habit and habitat :** It is a burrowing snake feeding on small insects, earthworms and soft larval insects.

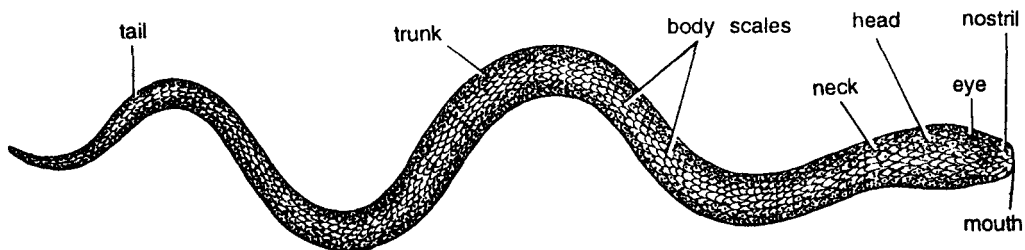

Fig. 93. *Typhlops*.

**Comments :**

- (1) Commonly known as **blind snake**. Body divided into **head, neck, trunk and tail**.
- (2) Body is elongated, cylindrical, measuring about 175 to 180 mm and covered by thin **overlapping cycloid scales** in multiple rows over whole body.
- (3) Animal looks like earthworm and is of dark chocolate colour.
- (4) There is no **distinct head** and also there is no differentiation between dorsal and ventral scales which are in **multiple rows** over whole body. Head contains mouth nostril and eye.
- (5) Lower jaw without **teeth**, maxilla toothed and transversely placed, ectopterygoid and squamosal absent and pterygoid separate from quadrate.
- (6) **Rostral, nasal, ocular and pre-ocular shields** are larger.
- (7) Eyes are indistinct and covered with scales. They are immobile and **without eyelids**.
- (8) **Limbs, feet, ear openings, sternum, urinary bladder absent**. Mandibles join anteriorly by ligament. Tongue slender, bifid, protrusible. Left lung reduced.

**Identification :** Since this snake contains indistinct head and eyes and above features, hence it is *Typhlops*.

### 94. Python : Ajgar

**Classification :** Same as that of *Typhlops* (upto Sub-order).

Family..... **Boidae** → Vestiges of pelvic girdle and hind limb as 2 spurs on ventral sides.

Genus..... *Python*

**Geographical distribution :** *Python* has world-wide distribution except New Zealand.

**Habit and habitat :** They are found mostly on ground, in trees of tropical jungle, in dry, rocky or sandy places. They **kill birds, goats, sheep, deer, cows, dogs, horses and even tigers**. They can also **swim** in water. **Oviparous**.

**Comments :**

- (1) Commonly known as **Ajgar**, is a favourite snake in a **serpentarium**.
- (2) Animal is huge, **massive, voluminous**, measuring about **10 metres** in length, and weighing nearly **110 kilograms**.
- (3) Body is covered with **small scales** in 60-75 rows. Body divided into **head, neck, trunk and tail**. Head contains mouth, nostril and eyes.
- (4) Dorsal side has **brown pigmentation** with **dark grey rhomboid edged spots** while **ventral side is greyish** with yellow brown spots.
- (5) **Head** is distinct from the **neck** and covered with **symmetrical shields** or small scales. **Eyes** are free and functional with vertical pupil.

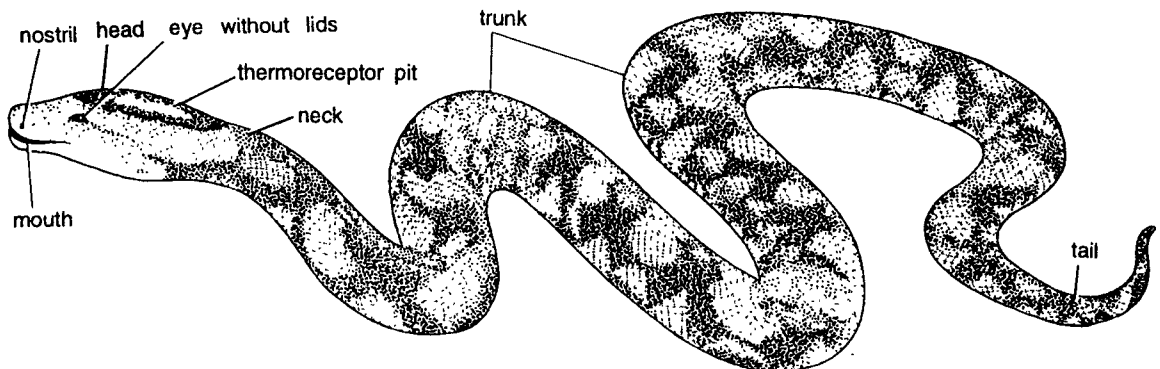

Fig. 94. Python.

- (6) **Mandibles, pterygoids, palatines, maxillae and premaxillae** contain teeth. **Maxilla, palatine** and pterygoid movable.
- (7) **Rostral scale** of head contains a deep thermo-receptive pit. Lancet-shaped brown mark present over head. Parietal, loreal and temporal regions are covered with irregular plates. Supra-labials are 11-13, 1st two contain pit and 7th touching eye, infralabials 16-18.

**Special features :** *Python* is very **lethargic** but during feeding and on seeing prey, it becomes very active and coils around the prey. It kills the prey by pressing within the coils of its massive muscular body and gradually it shoves the prey. Indian *Python* is *P. molurus*. It is one of the largest living serpent.

**Identification :** Since this snake has huge and massive looking body and above features, hence it is *Python*.

## 95. *Eryx* : Rat Snake

**Classification :** Same as that of *Typhlops* (upto Sub-order).

Family.....**Boidae** → Vestiges of pelvic girdle and hind limbs as 2 spurs on ventral sides.

Genus.....*Eryx*

**Geographical distribution :** *Eryx* is found all over India, Sri Lanka, Africa and Asia.

**Habit and habitat :** *Eryx* is found in sandy regions. It remains **hidden** in sand and feeds on lizards, frogs and mice.

**Comments :**

- (1) Commonly called as **sand boa**, the common **double mouthed** snake (**dumuhi**).
- (2) It is elongated measuring one meter in length. Body divided into **head, neck, trunk** and **tail**. Head contains eyes and nostril.
- (3) **Pinkish grey** dorsal surface has irregular **brown patches** while ventral surface is **yellowish**.
- (4) Entire body is covered with **40-45 rows** of **small scales**, sometimes keeled in tail region. Ventral scales do not run across the body.
- (5) **Head** and **neck** indistinguishable. Head scales primitive and 3 scales enlarged.
- (6) **Eyes** are small with vertical pupil and are reduced due to burrowing life.
- (7) **Nostrils** are slit-like. Tympanum absent.
- (8) Tail region is as thick and blunt as head and hence it is called **Dumuhi**.

**Special features :** *Eryx* is characterized by the blunt tail end looking like head. Sometimes snake crawls back and hence it is called as **double-headed snake** but actually there are no second mouth and head.

It kills the prey by **constriction**.

**Identification :** Since this snake has blunt tail and above features, hence it is *Eryx*.

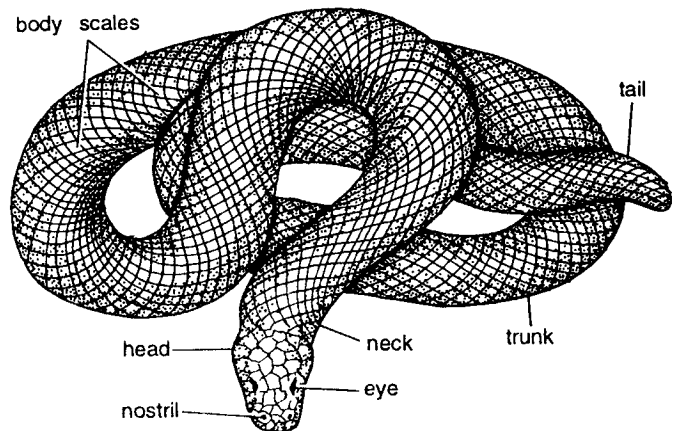

Fig. 95. *Eryx*.

## 96. *Ptyas* = *Zamenis* : Dhaman

**Classification :** As in *Typhlops* (upto Sub-order).

**Family**.....Colubridae → Facial bones movable. No fang.

**Genus**.....*Ptyas*

**Geographical distribution :** *Ptyas* is commonly found on plains in India, Myanmar, Java, Europe, Asia, Africa, North and Central America.

**Habit and habitat :** It feeds on **frogs, toads, mammals, even snakes and lizards**. It can climb on trees and is oviparous.

**Comments :**

- (1) Commonly called as **Rat snake** or **Dhaman**. It attacks forcibly like a whip and hence it is also called as **rope snake**.
- (2) Body is elongated with dirty, yellow colour measuring about 3 metres in length and covered with 16-17 rows of slightly **keeled scales**. Body divided into **head, neck, trunk and tail**.
- (3) **Head** differentiated from neck and contains slit-like **mouth, eyes, nostrils** and a **bifid tongue**.
- (4) **Loreal** region is concave having pre-subocular, nasals and nostrils and supra-ocular forming a ridge on eye.
- (5) It is **non-poisonous** and active snake.

**Special features :** **Rat snake** bites viciously and **coils** around the victim firmly by its **prehensile tail**. It emits **foul odour** and secretes black secretion from the anal glands.

**Identification :** Since this snake contains ridge on eye and above features, hence it is *Ptyas*.

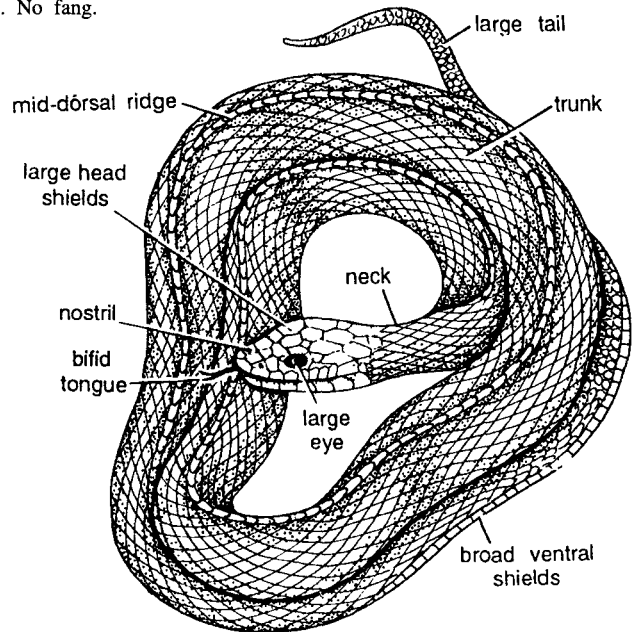

Fig. 96. *Ptyas*.

## 97. *Natrix* : Water Snake

**Classification :** Same as that of *Typhlops* (upto Sub-order).

**Family**.....Colubridae → Facial bones movable. No fang.

**Genus**.....*Natrix*

**Geographical distribution :** *Natrix* is widely distributed in U.S.A., Mexico, North Africa and India.

**Habit and habitat :** It is found in fresh-water, hidden under water vegetation or grasses. It is **diurnal, oviparous** and feeds on fishes and frogs.

**Comments :**

- (1) Commonly called as **water snake**. It is non-poisonous. *Natrix piscator* is the common Indian water snake.
- (2) Body is covered with **epidermal scales** and **chess-board** like black spots. Body divided into **head, neck, trunk and tail**.
- (3) **Head** is distinct and comprises bulging **eyes, slit-like mouth** and **bifid tongue**. Head scales are large, called as shields. Belly scales plate-like, while side scales smaller. Bifid tongue protrude between upper and lower jaw.



- (4) Both jaws contain **teeth** but **without fangs**. Maxillaries horizontal forming most part of upper jaw.  
 (5) Facial bones movable. Squamosal loosely attached to skull. Tympanum absent.

**Identification** : Since this snake contains chess-board like black spots and above features, hence it is *Natrix*.

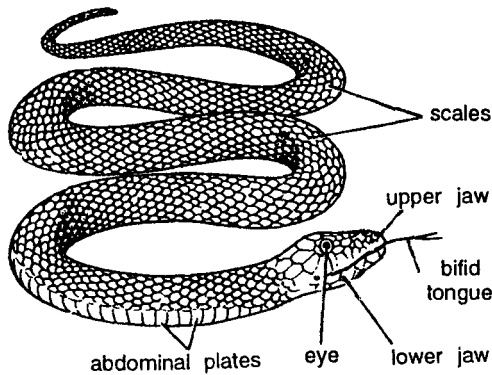

Fig. 97. *Natrix*.

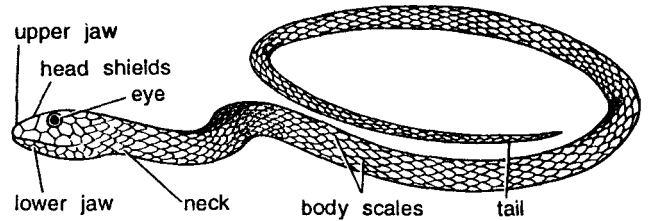

Fig. 98. *Dendrophis*.

## 98. *Dendrophis* : Tree Snake

**Classification** : Same as that of *Typhlops* (upto Sub-order).

Family.....Colubridae → Facial bones movable. No fang.

Genus.....*Dendrophis*

**Geographical distribution** : *Dendrophis* is found in Asia, South America and Australia.

**Habit and habitat** : It is adapted for arboreal life. It lives on trees and feeds on frogs. **Diurnal** and **oviparous**.

**Comments** :

- (1) *Dendrophis*, a harmless and **non-poisonous** snake.
- (2) Commonly called as **tree snake**.
- (3) Snake is elongated and cylindrical with pointed tail measuring about **2 metres** in length and having yellow stripes. Body divided into head, neck, trunk and tail. Head contains mouth and eyes.
- (4) **Head** is large and covered by large plate-like **keeled shields** forming **13 or 15 rows**.
- (5) Scales of vertebral row enlarged. Belly scales plate-like while side scales are small.
- (6) **Ventrals** have a pair of suture-like lateral keel and notch on sides which helps in climbing.
- (7) Fangs absent but teeth present.
- (8) **Eyes** covered with transparent and fused membrane. Tympanic membrane absent.

**Identification** : Since this snake contains keel and notch on sides and above features, hence it is *Dendrophis*.

## 99. *Hydrophis* : Sea Snake

**Classification** : Same as in *Typhlops* upto sub-order.

Family.....Hydrophidae → Tail compressed used for swimming.

Genus.....*Hydrophis*

**Geographical distribution** : *Hydrophis* is found in India, along the Pacific coast from southern Mexico to northern South America, in the Bay of Bengal and Malaysia Archipelago.

**Habit and habitat** : It inhabits water, feeding on fishes.

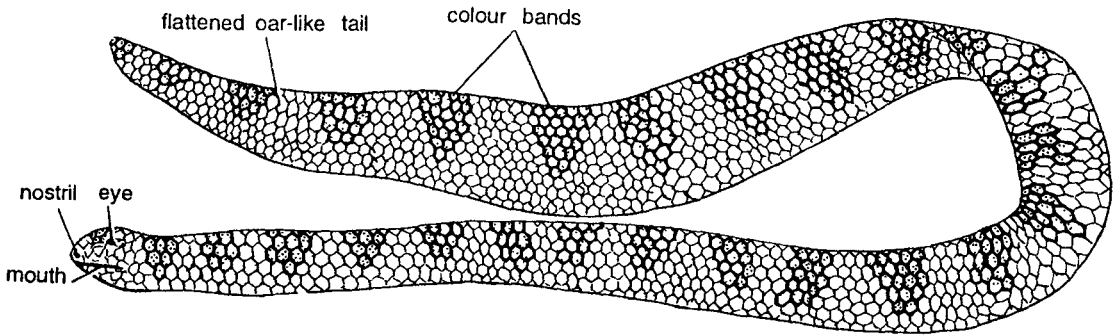
Fig. 99. *Hydrophis*.**Comments :**

- (1) Commonly called as **sea snake**. Body divided into **head, neck, trunk and tail**.
- (2) Body is **elongated, laterally compressed**, about **2 metres** in length, and covered with **small scales**.
- (3) General pigmentation is dark olive green above with yellowish cross bars and whitish area below.
- (4) **Head** is indistinct and covered by **large shields**. Head contains **nostril, mouth and eye**.
- (5) **Ventral scales** are small. **Loreal shield** is absent. One pre-ocular, 2 post-oculars and 7-8 supra-labials present. 3rd and 4th supra-labials touch the eyes.
- (6) **Maxillary teeth** 14-18 behind the poison fangs.
- (7) **Eyes small** with rounded pupil.
- (8) Sea snakes are **oviparous** and they come out of water for egg laying.

**Special features :** *Hydrophis* is **deadly poisonous** or venomous snake and very dangerous to mankind. Its venom is neurotoxic. The tail is compressed and adapted for swimming. Tail in oar like.

**Identification :** Since the animal has compressed tail and above features, hence it is *Hydrophis*.

## 100. *Crotalus* : Rattle Snake

**Classification :** Same as in *Typhlops* (upto Sub-order).

Family..... Viperidae → Paired erectile fangs in front of upper jaw.

Genus..... *Crotalus*

**Geographical distribution :** *Crotalus* is found in U.S.A. and Mexico, North America and contains *Crotalus horridus*, a common rattle snake of U.S.A. *Crotalus confluentus* is found in western America. About 40 species and varieties are found in Western Hemisphere and approximately 20 in U.S.A.

**Habit and habitat :** It is adapted for terrestrial life. During winter season it **hibernates** under the ground. The snake is carnivorous, **nocturnal** and feeds on small mammals.

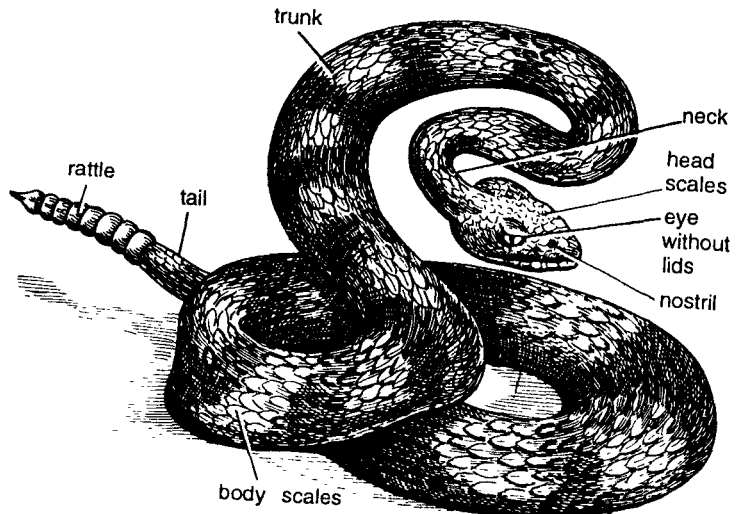
Fig. 100. *Crotalus*.

**Comments :**

- (1) Commonly called as **Rattle snake**.
- (2) Body is elegantly elongated, measuring 2 to 3 metres in length. Body divided into **head, neck, trunk and tail**. Head contains nostrils, eyes, mouth and head scales.
- (3) General surface greyish brown with dark bands and handsome pigmentation pattern.
- (4) **Head** is triangular in shape, distinct from the neck having small nostrils and ventral mouth. Upper side of head has small scales.
- (5) **Eyes** are small, without eyelids, and a **sensory pit** is present between eye and nostril.
- (6) There are two **erectile fangs** in front of jaw, one on each maxillary bone and folded backwards when not in use.
- (7) Tongue bifid and **protrusible**. Two pairs of internasals present.

**Special features :** The snake is immediately characterized by the presence of a **rattle** at the end of the tail. Rattle is derived from moulting epidermis consisting of **10-12 hollow segments**. During fast locomotion, tail is vibrated and rattle produces characteristic rattling sound which warns the intruder. It is a **deadly poisonous snake** and is **viviparous**.

**Identification :** Since this snake contains rattle in tail and above features, hence it is *Crotalus*.

### 101. *Vipera* : Pitless Viper

**Classification :** Same as that of *Typhlops* (upto Sub-order).

Family.....Viperidae → Paired erectile fangs in front of upper jaw.

Genus.....*Vipera*

**Geographical distribution :** Vipers are Old World snakes except Madagascar. Viper has been reported from Europe, Asia, Sri Lanka, Myanmar and India.

**Habit and habitat :** It is found in rocky and bushy regions. It feeds on **mice, rats, lizards and birds**.

**Comments :**

- (1) Commonly called in Hindi as **Kadar** or **Dobia** or pitless viper.
- (2) It is a common highly poisonous snake. Body divided into **head, neck, trunk and tail**.
- (3) Body measures 2 meters in length. **Head** large, **flat, triangular** and covered with small scales. Shields on undersurface of the tail are subdivided. **Head** contains, **mouth, bifid tongue, nostril** and **eyes** without eye lids.
- (4) Colour is brownish but it varies according to its environment. Body is covered with **keeled scales**. Large black spots arranged on the back. Head and body separated by constriction of neck.

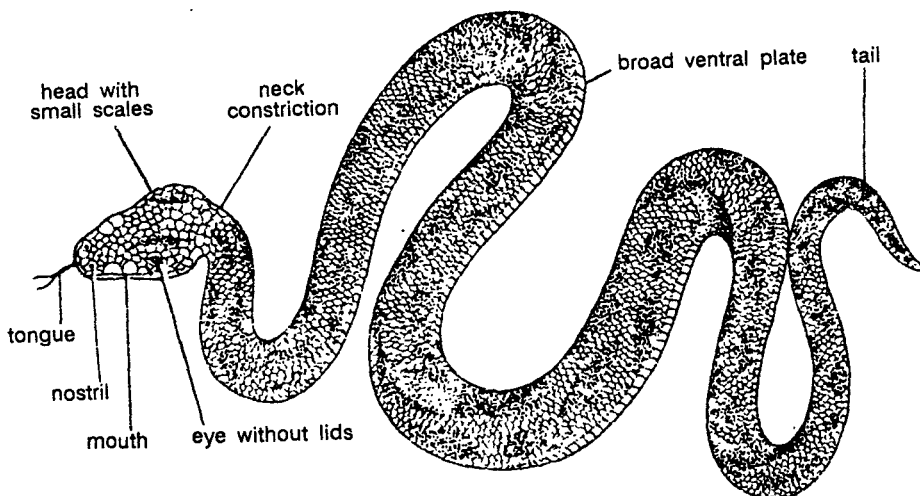

Fig. 101. *Vipera*.

- (5) Facial bones movable, maxilla is small and contains **long** and **movable poison fangs** with **canals**.
- (6) **Paired erectile fangs** in front of upper jaw, one on each maxillary bone and folded backward when not in use (solenoglyphs).
- (7) **Maxillaries** short, thick and **movable** in **vertical plane**.
- (8) No **pit** between **nostril** and **eye**.
- (9) **Supra-labials** are 10 to 12. 4th supralabial is largest and it does not reach up to eye. Ventral plates large.
- (10) **Snout** is **angulate**, **nasal opening** prominent and **largest** and **eyes** have white margin with **golden iris** and elliptical pupil. Tail narrow.

**Special features** : The snake remains coiled with the head in the centre of the coil and with least provocation or disturbance, tongue is protruded, body **rhythmically swells** and **hissing sound** is produced. Its bite is fierce and it strikes to one side with a sudden and forceful spring. Before striking it **hisses loudly**. Its bite is fatal to man. Its native name is **Sus-Karna** symbolizing its powerful hissing.

**Identification** : Since the snake contains characteristic ventral shields and above features, hence it is *Vipera*.

## 102. *Ancistrodon* = *Agkistrodon* : Himalayan Pit Viper

**Classification** : Same as that of *Typhlops* (upto Sub-order).

Family..... Viperidae → Paired erectile fangs in front of upper jaw.

Genus..... *Ancistrodon*

**Geographical distribution** : Found in hilly region in north and eastern parts of India and Asia.

**Habit and Habitat** : It is **viviparous**.

**Comments** :

- (1) Commonly called as **Himalayan pit viper**.
- (2) Body is not much elongated, measures about 1 metre in length. Body divided into head, neck, trunk and tail.
- (3) Colour is bluish brown with **dark brown** or **black spots** which appear like **crossbars**.
- (4) **Head** is triangular containing **nostrils**, **eyes** and **mouth**. A characteristic **loreal pit** is present on each side of upper jaw separating eye and nostril. **Head shields** are large.

(5) **Upper lip** is **slightly raised** in rostral region, post-ocular two, supra-ocular enlarged sideways to form shield over the eye and pre-ocular three in number.

(6) **Eyes** are big with golden iris and **vertical pupil**.

**Special features** : **Pit viper** is a shy and alert snake. Even on slight disturbance it runs back to its shelter.

It is a **poisonous** snake having well-developed, erectile poisonous and sheathed **fangs**.

**Identification** : Since this snake contains large head shields and loreal pit and above features, hence it is *Ancistrodon*.

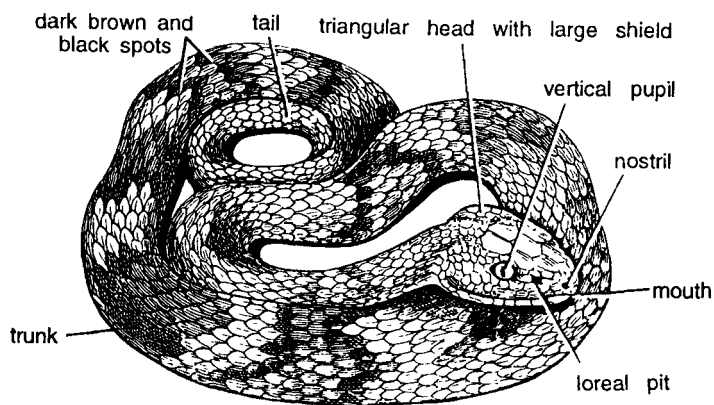

Fig. 102. *Ancistrodon*.

### 103. *Bungarus* : Krait

**Classification :** Same as in *Typhlops* (upto Sub-order).

Family.....Elapidae → 2 or more short, rigid erect fangs.

Genus.....*Bungarus*

**Geographical distribution :** *Bungarus* is found in South East Asia, all over India and Malaysia.

**Habit and habitat :** It is a common snake, found in the crevices of walls, under the logs and stones. It is **nocturnal** and feeds on smaller snakes, toads and mice. It is shy and considerate. It attacks only when disturbed or trodden with foot.

**Comments :**

- (1) Commonly called as **Krait**.
- (2) Body is elongated and cylindrical, measuring one metre in length. Body divided into **head, neck, trunk and tail**.
- (3) Colour of body steel-blue and dark-blue. **Dark-blue, patches** alternate with **white cross bands**.
- (4) **Head** is not differentiated from the neck. **Loreal absent**. Post-ocular, preocular and supra-labial 2, 1 and 7 in number respectively. **Fangs small**. Head contains **eyes, nostrils, bifid and protrusible tongue**.
- (5) **Eyes** are of moderate size with **round pupils**.
- (6) **Scales** are smooth forming 13-17 rows. **Ventrals** are 194-234 and **caudals** 42-52.
- (7) **Large mid-dorsal hexagonal scales** are present. Ventral scales beyond the anal region are in a single row.
- (8) **Oviparous**. Female shows **parental care**.

**Special features :** *Bungarus* is a **deadly poisonous snake**, its venom being more poisonous than that of cobra. Its venom is **neurotoxic** affecting brain. After an hour of the bite, the victim feels sleepy and if immediate antivenom is not given, the patient may die.

**Identification :** Since this snake contains hexagonal scales on body on dorsal side and above features, hence it is *Bungarus*.

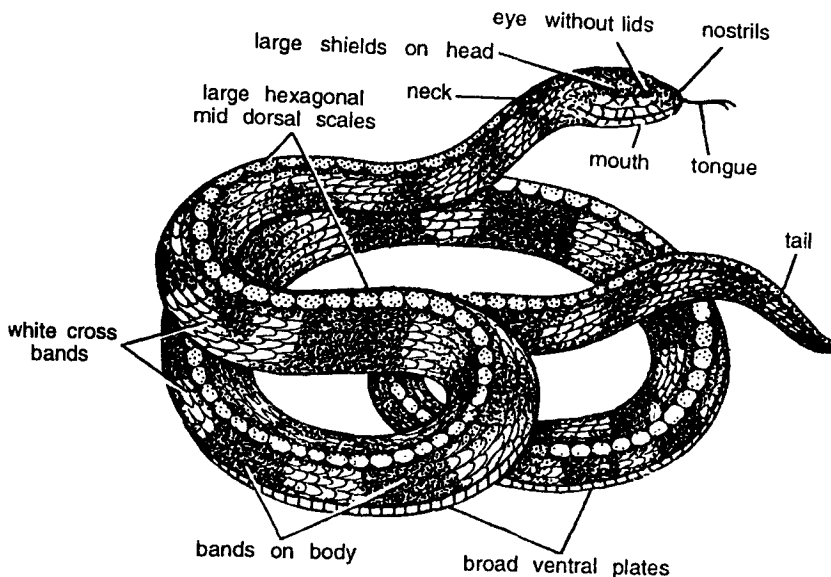

Fig. 103. *Bungarus*.

## 104. *Naja naja* : Cobra

**Classification :** Same as that of *Typhlops* (upto Sub-order).

Family.....Elapidae → 2 or more short, rigid erect fangs.

Genus.....*Naja naja*

**Geographical distribution :** *Naja* has wide distribution, found in India, Africa, China, Philippines, Tasmania, Australia, New Guinea and Egypt.

**Habit and habitat :** Cobra is **diurnal**, shy, living in holes, under stones, mud walls and in thick vegetation. It is **oviparous**, **carnivorous** and feeds on frogs, rats, lizards and other snakes. It hibernates. Three varieties of cobras are found in India : (i) **Binocellate form** having spectacle-like mark connected by U, found in Maharashtra, (ii) **Monocellate** with single oval mark surrounded by ellipses found in Bengal, (iii) **Non-cellate** without mark found in Rajasthan, Gujarat and Madhya Pradesh.

**Comments :**

- (1) Commonly known as **cobra**. *Naja naja* is Indian cobra or **Nag**.
- (2) Body measures **2 to 3 metres** in length and is wheatish (gehuwa) in colour. During hibernation the colour becomes golden but on exposure to light it changes to brown.
- (3) Body divided into **head, neck, trunk and tail**. **Head** contains **mouth, eyes and nostrils**.
- (4) **Neck** region is dilatible with elongated ribs. It expands to form **hood** which contains binocellate mark on dorsal surface. Some persons call it figure of ten. There is a white band around mark.
- (5) **Third shield** of upper labia or lip large and extending from ocular to **nasal shield**. **Ocular shield** bears eye and nasal shield bears opening of nostril. **Eyes** with narrow pupils.
- (6) A tiny wedge-shield on the undersurface of the 4th and 5th lower labials.
- (7) Tail shields on the undersurface of the tail in a double row.
- (8) Body is covered by smooth **oblique scales**.
- (9) Maxillary bone extends beyond palatine. **Poison fangs** are followed by 1-3 small teeth. Loreal absent. Nostrils large and vertically elliptical. **Frontal shield** truncated.

**Special features :** Cobras are **deadly poisonous snakes**. They rise their hood when alarmed and the hood sways back and forth for striking the object. During this period it produces hissing sound. It will not strike if intruder becomes standstill. The snake-bite cases should be immediately attended by medical persons. The snake (*Naja naja*) is very common in India. It is worshipped on **Nagpanchami** day. The cobra bite is cured sometimes in villages by snake charmers by Mantra or sometimes by sucking poison out of the wound. The presence of a jewel in the head is not correct. *Naja bungarus* is called as King cobra because it eats other cobras.

**Identification :** Since this snake has characteristic hood and its mark and above features, hence it is *Naja naja*.

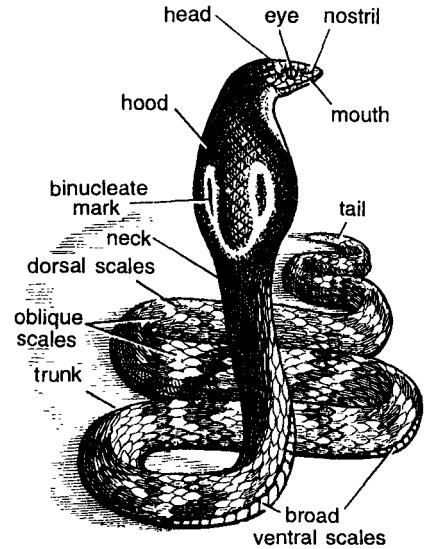

Fig. 104. *Naja naja*.

## 105. *Crocodylus* : Mugger

### Classification :

Phylum.....	Chordata	→	Dorsal tubular nerve cord, notochord and gill-slits present.
Group.....	Craniata	→	Definite head. Cranium with brain present.
Subphylum.....	Vertebrata	→	Vertebral column present.
Division.....	Gnathostomata	→	Jaws and paired appendages present.
Superclass.....	Tetrapoda	→	Paired limbs, lungs, cornified skin and bony skeleton.
Class.....	Reptilia	→	Scaly vertebrates with right and left aortic arches. Single condyle. Pulmonary respiration. Embryo with amnion and allantois.
Sub-class.....	Diapsida	→	Skull with two temporal openings separated by postorbital and squamosal.
Order.....	Crocodylia	→	Body and head large. Jaws powerful. Skin thick and leathery. Tongue non-protrusible Heart 4-chambered.
Family.....	Crocodylidae	→	Snout not distinct from the rest of the skull.
Genus.....	<i>Crocodylus</i> (Magarmach)		

**Geographical distribution :** *Crocodylus* is found in Southern Asia, Africa, Australia, Central America and India. Triassic to Recent.

**Habit and habitat :** It is found in rivers and lakes. The animal makes 10 to 13 metres long tunnel below the level of water. The opening of the tunnel is used as entrance and the other side is used to deposit the eggs.

### Comments :

- (1) Commonly known as **Mugger**.
- (2) Body is stout, elongated, **4 to 6 metres** in length and divided into **head, neck, trunk and tail**.
- (3) Surface covered by leathery armour of **osteoscutes** bony scutes arranged in **transverse rows**.
- (4) Upper part of the body is dark olive brown with black spots or bends.
- (5) Head long and triangular and narrows towards snout which is not differentiated from the rest of the skull. **Jaws long, powerful, rimmed with numerous bluntly conical and unequal teeth**, dental formula 16-19/14-15. The first tooth fits into a pit and fifth mandibular tooth into a notch on the outer side of upper jaw.
- (6) **Ear opening** small and **protected by a small flap** of skin.
- (7) Tongue **not protrusible**.
- (8) Tail long, heavy and **laterally compressed**.
- (9) **Forelimbs** and **hind limbs** short and **pentadactyle**, with 5 fingers and 4 toes, ending in claws and with webs.
- (10) **Heart 4-chambered** with separate ventricles. Bladder absent.

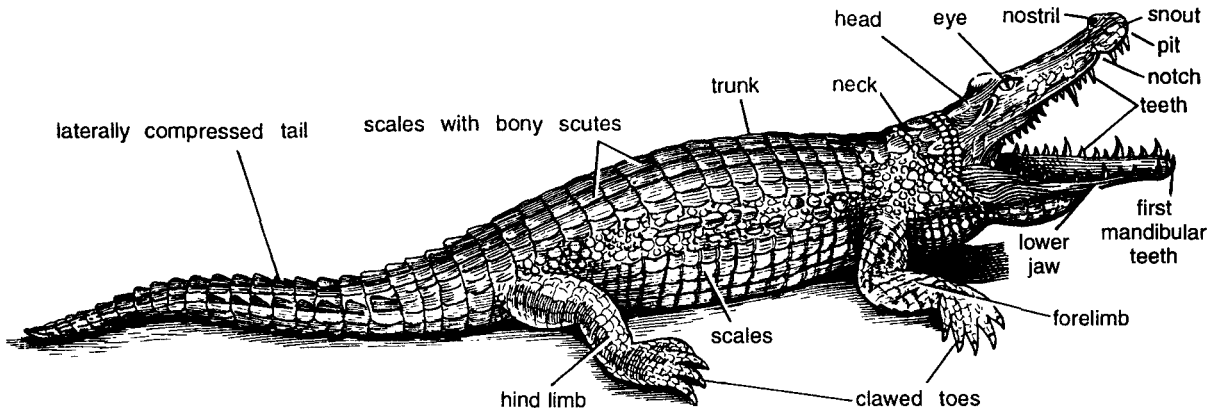

**Fig. 105.** *Crocodylus*.

**Special features :** Crocodile is **dangerous** to mankind. It can eat the man.

**Identification :** Since this reptile has long and pointed snout with conical teeth and above features, hence it is *Crocodylus*.

## 106. Alligator

**Classification :** Same as that of *Crocodylus*.

Genus..... *Alligator*

**Geographical distribution :** *Alligator* is found in China and North America.

**Habit and habitat :** Inhabits shallow water and on slight disturbance buries in sand.

**Comments :**

- (1) *Alligator* resembles superficially with *Crocodylus*.
- (2) **Body** measures 3 to 4 metres in length. The upper part steel-grey and sides olive green. Body divisible into **head, neck, trunk and tail**.
- (3) Body is covered with thick leathery skin **containing scutes**. The **dorsal bony scutes** do not articulate with each other. The **ventral scutes** are with or without very little ossification. **Mandibular symphysis** is short extending only to the level of 4th and 5th tooth. In water eyes and nostrils are exposed.
- (4) **Head** is broad and **snout** bluntly rounded. **Jaws** long, powerful, rimmed with numerous, bluntly conical teeth which are unequal. Teeth 17-20/17-22 on each side. The first and fourth mandibular teeth fit into the pits of upper jaw. **Tongue not protrusible**. Head contains **mouth, nostril** and **eyes**.
- (5) Small ear opening is protected by a flap of skin and nasal bones divide nasal aperture.
- (6) **Forelimbs and hind limbs** short, **pentadactyl** and ending in toes with webs inbetween.
- (7) **Tail long**, heavy compressed.
- (8) **Heart 4-chambered** with separate ventricles. **Bladder absent**.
- (9) Eggs are laid in nests.

**Identification :** Since this reptile has peculiar scales and above features hence it is *Alligator*.

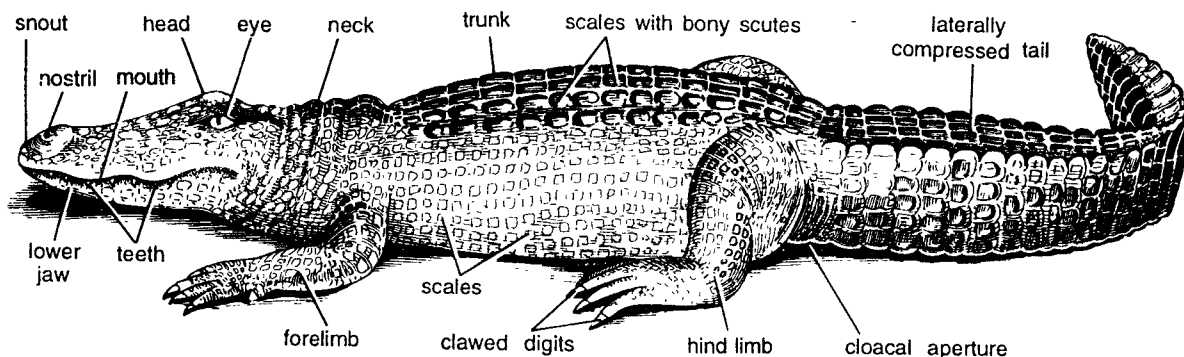

Fig. 106. Alligator.

## 107. Gavialis : Ghariyal

**Classification :** Same as that of *Crocodylus*.

Genus..... *Gavialis*

**Geographical distribution :** *Gavialis* is found in India in Ganges river, Myanmar and Malayasia. Indian species is *G. gangeticus*. Upper Cretaceous to present day.

**Habit and habitat :** It lives in Ganges river. It eats fishes.



**Comments :**

- (1) Commonly known as **Ghariyal** or **Naka**.
- (2) It is the largest of all crocodylians but **not dangerous** to mankind. Body divisible into **head, neck, trunk** and **tail**. Body measures 5 meters.
- (3) **Head** contains **eyes** and elongated **snout** with **nostrils** at the tip.
- (4) Body is covered with an exoskeleton of **bony** and **epidermal horny scales**. The upper part of the body dark olive green with dark markings.
- (5) **Head** large and produced into a long and narrow **snout** which is sharply distinct from rest of the skull. Jaws powerful, rimmed with various conical teeth. **Teeth** sub-equal and internal nares within the pterygoids. Upper **jaw contains 28** and lower jaw **25 teeth** on either side.
- (6) **Mandibular symphysis** is so long that it comprises a great portion of the splenial bones and extends backwards almost to the level of the last teeth. The first and fourth lower teeth fit into grooves in the upper jaw.
- (7) **Forelimbs** and **hind limbs** short **pentadactyle** and ending in **clawed toes** with webs between. Vertebrae procoelus.
- (8) Tongue is **not protrusible**. **Heart 4-chambered** with separate ventricles. Bladder absent.
- (9) Tail is strong and powerful and laterally compressed, containing vertical scutes.
- (10) A flap of skin covers the ears. In male the nose is very much swollen which is inflated like a beak when nostrils are closed.

**Identification :** Since the animal contains **long** and **narrow** snout and all above features, hence it is **Gavialis**.

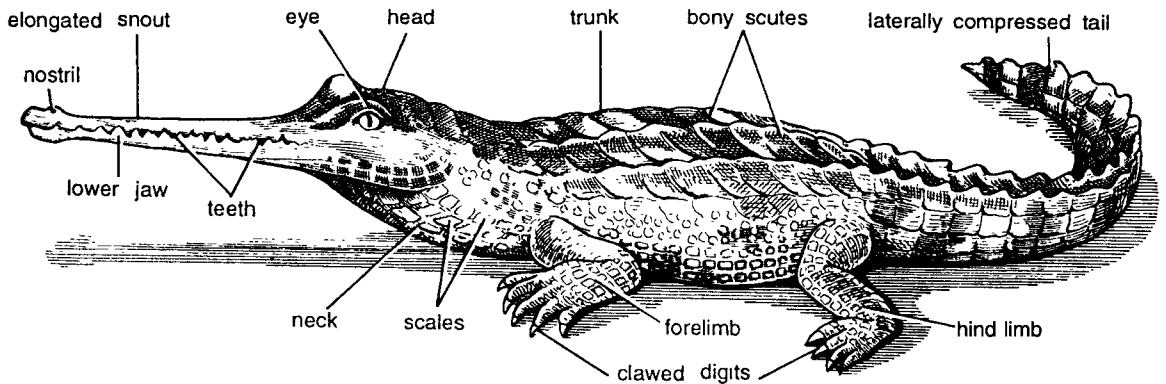

Fig. 107. *Gavialis gangeticus*.

**Table :** Showing distinction of *Crocodylus*, *Alligator* and *Gavialis*.

Characters	<i>Crocodylus</i>	<i>Alligator</i>	<i>Gavialis</i>
1. Length.	4 to 6 metres.	3 to 4 metres.	5 metres.
2. Colour.	Dorsal side olive green with black spots or bands.	Steel grey.	Dark olive green.
3. Snout.	Long and pointed.	Short but broad.	Elongated.
4. First and fourth mandibular teeth of lower jaw.	Fit into a pit and groove of upper jaw, respectively.	Fit into pits of upper jaw.	Fit into grooves of upper jaw.
5. The lower jaw rami.	Do not unite beyond 8th tooth.	Do not meet beyond 5th tooth.	Unite upto 14th tooth.
6. Teeth.	Unequal.	Very unequal.	Sub-equal.

## Extinct Reptiles (Dinosaurs) : Models

Mesozoic era had witnessed both rise and fall of reptiles. Large number of ruling reptiles underwent process of extinction and fossilization. Some of the important extinct reptiles are discussed below.

### 108. *Ichthyosaurus*

**Classification :** Same as that of *Crocodylus* (upto Class).

**Sub-class.....Parapsida** → Dorsolateral temporal openings in skull bounded by supra-temporal and post frontal.

**Genus.....*Ichthyosaurus***

**Comments :**

- (1) This is the model of fish-like extinct reptile.
- (2) Extreme **secondary adaptation** to aquatic life. Body divided into **head, neck, trunk and tail**.
- (3) Dorsal and caudal fins superficially extremely fish-like.
- (4) **Paddle-like** paired fins extremely modified, acting as balancing and steering device.
- (5) Long **beak** armed with numerous sharp teeth.
- (6) Greatly enlarged eyes with **sclerotic plates** like those in birds tail forked.
- (7) *Ichthyosaurus* first appeared in Triassic, reached their climax in Jurassic, were rarer in Cretaceous and became extinct by the end of Upper Cretaceous.

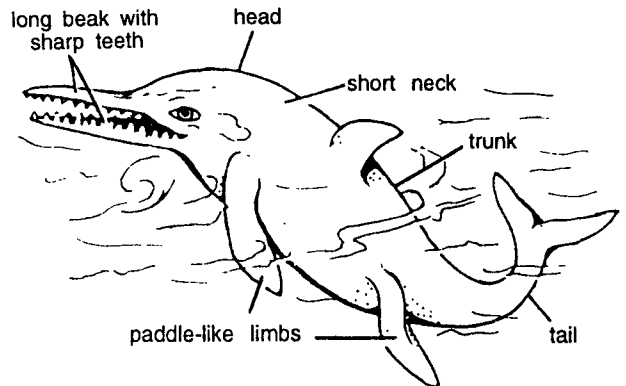

Fig. 108. *Ichthyosaurus*.

- (8) Causes of their extinction are not satisfactorily known.

**Identification :** Since the beak contains sharp teeth and all above features, hence it is *Ichthyosaurus*.

### 109. *Dimetrodon*

**Classification :** Same as in *Crocodylus*.

**Sub-class.....Synapsida** → Skull with a single lateral temporal opening.

**Genus.....*Dimetrodon* (= *Pelycosaur*)**

**Comments :**

- (1) This is the model of extinct mammal-like reptile with a single lateral temporal vacuity lying below post orbital and squamosal.
- (2) Body divided into **head, neck, trunk and tail**.
- (3) Head small. **Teeth** in both jaws.
- (4) They were found in upper carboniferous and lower permian.
- (5) Above mammal like reptile was more than 10 feet long having a dagger shaped stabbing and holding teeth.
- (6) Hind limbs and forelimbs well developed.
- (7) Characteristic feature is presence of **dorsal sail** over backbone. The **sail** comprises of elongations of neural spines covered with skin.

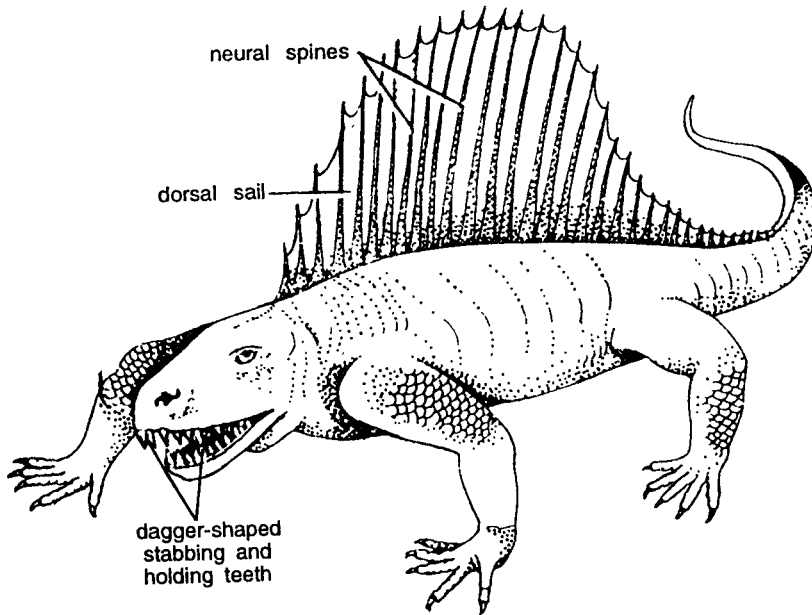

Fig. 109. *Dimetrodon*.

(8) Tail comparatively smaller.

(9) They became extinct in Jurassic period and they might have given rise to ancestors of mammals.

**Identification :** Since the fossil contains dorsal sail and all above features hence it is *Dimetrodon*.

## 110. *Brontosaurus*

**Classification :** Same as in *Crocodylus* (upto Class).

Sub-class..... *Diapsida* → Skull root with 2 openings behind eye.  
 Order..... *Saurischia* → Ischium and pubis diverge. 4-footed.  
 Genus..... *Brontosaurus*

**Comments :**

- (1) This is the model of *Brontosaurus* commonly called as **giant dinosaur**.
- (2) **Heaviest** dinosaur of Upper Triassic.

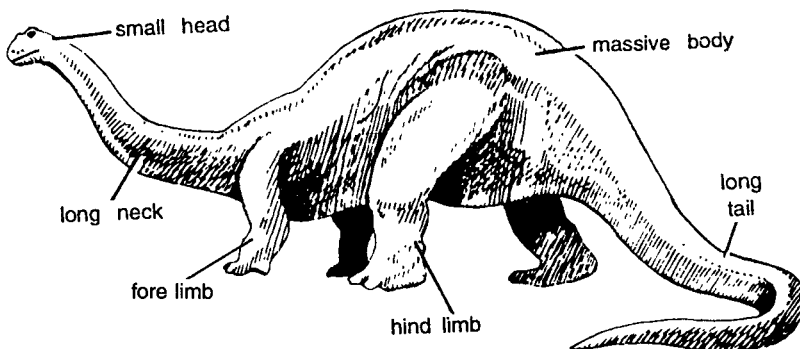

Fig. 110. *Brontosaurus*.

- (3) This fossil reptile belongs to quite different branch of **Saurischia** called as **Sauropoda** which subsequently became quadruped.
- (4) **Massive** size. Hind legs disproportionately long giving them high-hipped and low shouldered appearance. They possessed tri-radiate pelvis. Hind limbs thick, large and stout than forelimbs.
- (5) **Size** approximately 20 to 25 metres and **weight** nearly approximately 5000-6000 kg. Body divisible into **small head, long neck, massive trunk and elongated tail**.
- (6) The backbone was extremely massive. **Vertebrae** were hollowed on sides for possible weight reduction.
- (7) The fossil reptiles are indicative that these great reptiles were swamp dwellers, living largely in rather shallow water, for they could stand or walk on bottom of water but could still breathe with their long necks.
- (8) Extinction of these reptiles is attributed for the very **small brain** and **large body**. Brain could not control all activities of the body and hence animals faced extinction.

**Identification** : Since the fossil contains massive size and all above features, hence it is **Brontosaurus**.

### 111. *Diplodocus*

**Classification** : Same as that of **Brontosaurus**.

Genus..... *Diplodocus*

**Comments** :

- (1) This is the model of the **longest Jurassic dinosaur** measuring 20-25 metres long and weighing approximately 5000-6000 kg.
  - (2) Body consist of **head, neck, trunk and tail**.
  - (3) **Head very small** with **small jaws** and exceptionally small brain only 6 inches long.
  - (4) Neck very much elongated tapering gradually anteriorly.
  - (5) **Trunk massive**. Forelimbs and hind limbs pillar-like. Huge hip region. Quadrupedal and herbivorous.
  - (6) Tail enormously elongated.
  - (7) Swamp dwellers. Body was supported by buoyancy of water.
  - (8) They always needed constantly lush green pasture to support their pedigree of bulky mass of body.
- Identification** : Since the fossil had elongated neck, small head and all above features, hence it is **Diplodocus**.

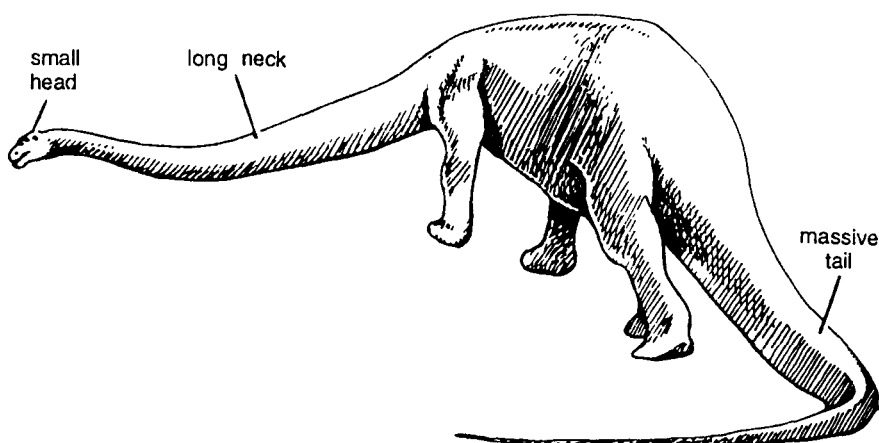

Fig. 111. *Diplodocus*.

## 112. *Tyrannosaurus*

**Classification :** Same as that of *Brontosaurus*.

**Genus.....** *Tyrannosaurus*

**Comments :**

- (1) This is the model of extinct reptile commonly referred to as **Tyrant dinosaur**.
- (2) Most formidable **animate engine of destruction** that ever lived. Body divided into **head, neck, trunk and tail**.
- (3) It was **terror** in plains of Western North America.
- (4) **Massive** and heavily built, attained a **length of 15 metres** and nearly **height of 6 to 7 metres** in walking position.
- (5) **Hind legs** were **tree-like**, huge and adapted for running.
- (6) Feet were like those of a **mammoth** bird with three powerful claws. **Forelimbs** very small.
- (7) Head large. Jaws large and provided with **3 to 6 inches long dagger-like teeth**. The beast used to hold the prey between legs and tear its body by its **powerful teeth**. It used to feed on contemporary herbivorous dinosaurs.
- (8) One wonders about their **tremendous attacking equipment**.

**Identification :** Since the dinosaur had powerful dagger shaped teeth and all above features, hence it is *Tyrannosaurus*.

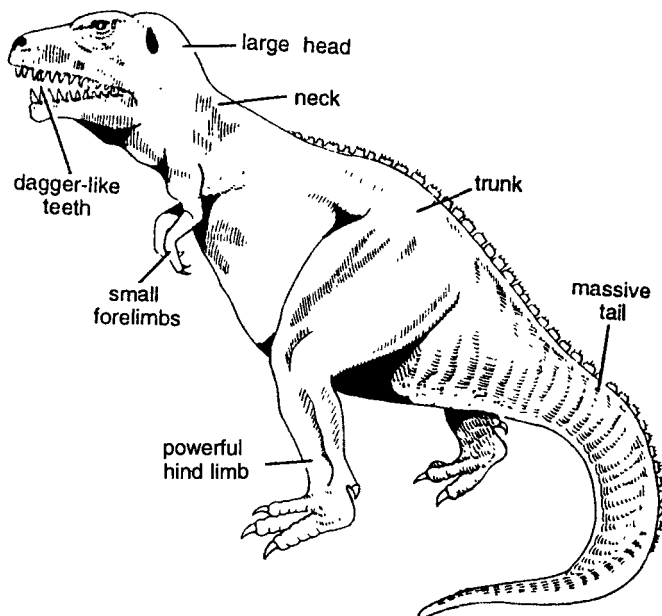

Fig. 112. *Tyrannosaurus*.

## 113. *Iguanodon*

**Classification :** Same as that of *Crocodylus* (upto Class).

**Order.....** Ornithischia → Pelvis bird-like.

**Genus.....** *Iguanodon*

**Comments :**

- (1) This is the model of the **most primitive** bird-like dinosaur with typical tetra-radiate pelvis.
- (2) Were prevalent in Upper Cretaceous. Descendants of primitive **thecodont** stock. Body divided into **head, neck, trunk and tail**.
- (3) **Head, neck** small and **trunk** heavy. **Hind legs** massive and forelegs not much reduced.
- (4) Fairly large measuring **approximately 5 metres in length**.
- (5) **Bipedal** locomotion. Hind legs heavy.
- (6) Peculiar feature of *Iguanodon* was its sharp dagger-like defensive.

**Identification :** Since the fossil had dagger like think and above features, hence it is *Iguanodon*.

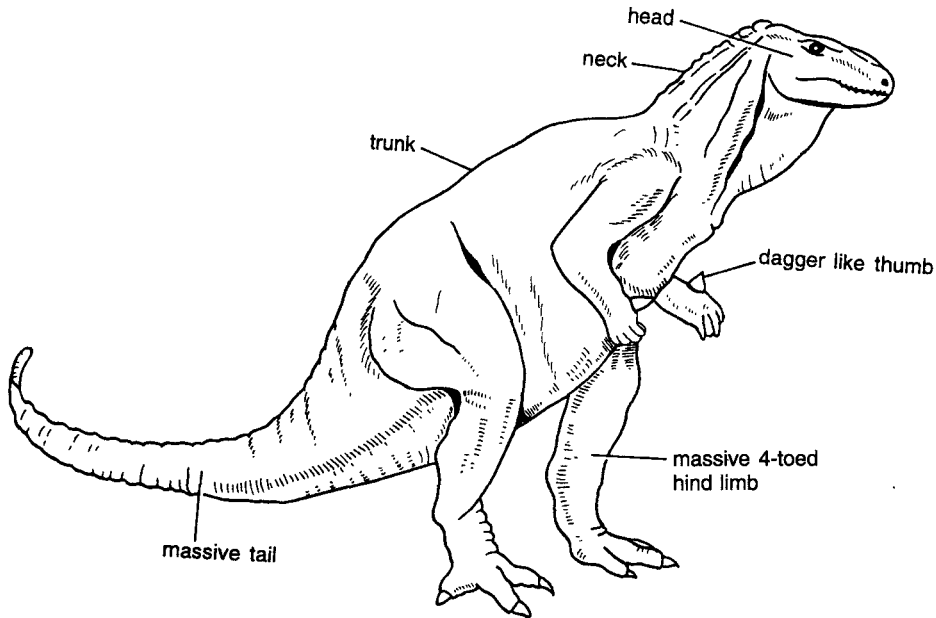

Fig. 113. *Iguanodon*.

**114. *Stegosaurus***

**Classification :** Same as those of *Iguanodon*.

Genus.....*Stegosaurus*

**Comments :**

- (1) This is the model of extinct **dreaded Jurassic quadrupedal dinosaur** with powerful armature.
- (2) Body size like **elephant** measuring approximately **8 metres** in length and **6000-7000 kg** in weight.
- (3) **Head** small, **trunk** and **tail** massive.

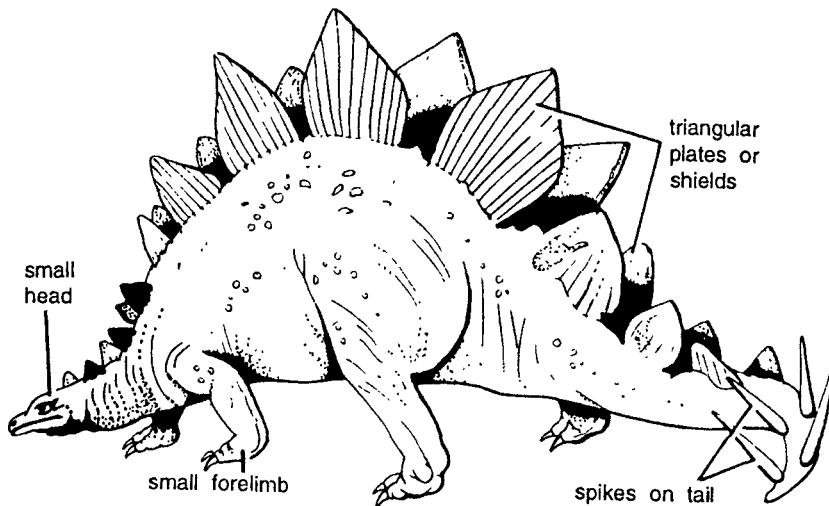

Fig. 114. *Stegosaurus*.

- (4) **Brain** casts depict size of brain hardly larger than size of terminal joint of one's finger.
- (5) **Trunk** and **tail** characterized by unique armature of heavy plates and spines.
- (6) Two rows of **dorsal plates are enormous**. They were flattened horizontally across back forming a complete roof. **Powerful tail** contained two or more pairs of powerful spines. Tail was powerful weapon of defence.
- (7) Another unique feature of this extinct reptile was **tremendous enlargement** of **spinal cord** at the base of tail, probably serving as real brain.
- (8) **Stegosaurus** was rear end fighter. When attacked it would pull its head and turn its rear end to enemy with roof plates and lashing vigorously at enemy with spiny tail.

**Identification** : Since the dinosaur has spike-like lashing tail and all above features, hence it is *Stegosaurus*.

### 115. *Rhamphorhynchus*

**Classification** : Same as in *Crocodylus*.

Order..... Pterosauria → Flying reptiles.

Genus..... *Rhamphorhynchus*

**Comments** :

- (1) This is the model of *Rhamphorhynchus* commonly referred to as **flying reptile** or **flying dragon**.
- (2) Primitive pterosaur with 1 meter wing span.
- (3) Pripedal but also attained **soaring flight**.
- (4) The wings differ strikingly from other wings because they were mainly 'little finger' wings. The fifth digit became extremely elongated and stretched with skin forming **patagium**.
- (5) **Thumbs** and other 3 fingers were small and armed with **claws**.
- (6) **Pterosaurs** were able to use the wings effectively for propulsion in the air but the fossil remains give no indication of powerful wing musculature.
- (7) Both jaws **beak-like** and contained **teeth**.
- (8) Fossil remains of all pterosaurs were obtained from marine rocks indicating their habitation.
- (9) Tail very much elongated.

**Identification** : Since the fossil contains toothed beak and above feature hence it is *Rhamphorhynchus*.

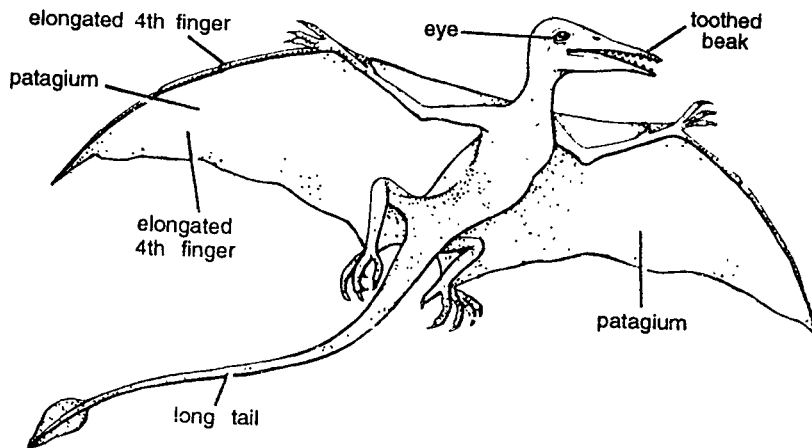

Fig. 115. *Rhamphorhynchus*.

## 116. *Pteranodon*

**Classification :** Same as that of *Rhamphorhynchus*.

Genus..... *Pteranodon*

**Comments :**

- (1) This is the model of the **bird-like extinct reptile** which was one of the most specialized forms being a giant type with a wing spread of about 25-30 feet.
- (2) **Head** was enormous with wide toothless beak.
- (3) A long **bony backwardly crest** on the back looked like a wicked weapon.
- (4) Body divided into **head, neck and trunk**.
- (5) Imagine this creature dropping like a plummet out of sky with its spear-like beak aimed at luckless fish.
- (6) **Large eyes** were provided with **sclerotic plates**.
- (7) Fourth finger elongated containing patagium.
- (8) **Brain** large. Cerebellum was much like that of birds and centre of great muscular co-ordination associated with flight.
- (9) They appeared during Jurassic period, had a reign of several million years through most of Cretaceous, and became extinct in late Cretaceous.
- (10) Emergence of flying birds probably had marked influence on the extinction of the above creature whose reign in the air had hitherto been undisputed.

**Identification :** Since the fossil shows backwardly directed crest like process and above features, hence it is *Pteranodon*.

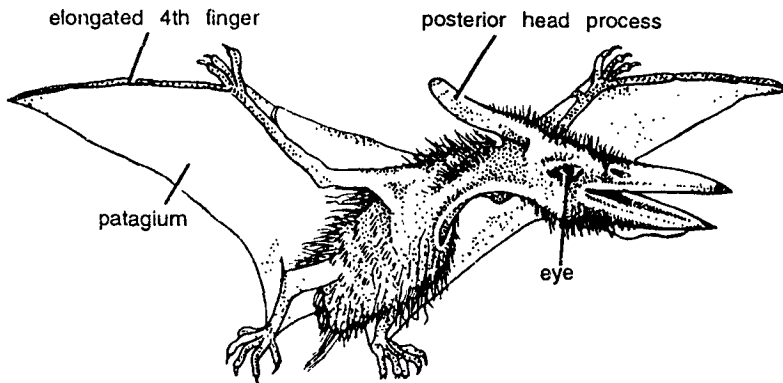

Fig. 116. *Pteranodon*.



## CLASS AVES (BIRDS)

### Natural history

Birds are the best known and most easily recognized of all animals. Birds have mixed with mankind in every aspect of life. They are unique in having feathers for flying which also cloth and insulate their bodies to make possible a regulated body temperature. They have easily avoided all kinds of enemies on land by adopting an aerial mode of life. The distinctive colouration and voices of birds appeal to human eyes and ears. Many birds are of economic importance because of their food habits. Certain kinds are hunted as game and few domesticated species contribute to man's food. Chickens are modern delicacies of the table.

Birds represent significant advance over all lower vertebrates in having (i) an insulated body covering, (ii) complete separation of venous and arterial circulation in the heart, (iii) regulated body temperature, (iv) high metabolic rate, (v) highly developed voice, sight and hearing, and (vi) the ability to fly.

Birds occupy all continents, oceans and islands, penetrating the Arctic beyond 80°N and the Antarctic, and live from sea level to above timber line on the Everest. They fully obey the laws of animal distribution. Albatrosses live in open ocean, ducks on marshy places, savanna, sparrows live on grasses, woodpeckers and others live on trees, and so on. In polar regions only few species are found. In temperate lands 150 to 200 kinds of birds may be found in localities at various seasons. Birds have well adapted migratory habits. They fly thousands of miles for breeding and nesting. Primitive people used wild birds for food and garments. Ducks, herons and other birds have been used as game. Feathers of birds provide ornaments to modern women and are also used in sports material.

### Expanded classification

#### CLASS AVES

1. Body covered with feathers.
2. Forelimbs modified as wings.
3. Adapted for flight and aerial mode of life.
4. Mouth formed by beak.
5. Single occipital condyle.
6. Heart 4-chambered. Lungs compact with air sacs.
7. No urinary bladder. Excretory waste as uric acid.

#### Sub-class A. Archaeornithes

1. Link between reptiles and birds.
2. Both jaws contained teeth in sockets.
3. Wings broadly flattened.
4. Fingers 3, each with claw. No pygostyle.  
Ex. *Archaeopteryx* (extinct).

#### Sub-class B. Neornithes

1. True birds.
2. Metacarpals fused. Sternum keeled.

#### Super-order 1. Odontognathae

1. New world extinct toothed birds.

2. Clavicles not fused. Sternum without keel.
3. Wings of vestigial humerus.

Ex. Extinct *Hesperornis*, *Ichthyornis*.

#### Super-order 2. Impennae

##### Order 1. Sphenisciformes

1. Forelimbs (wings) paddle-like.
2. Bones much compressed. Tarsometatarsus incompletely fused.
3. Found in Antarctica and Galapago islands.  
Ex. Penguins. *Aptenodytes forsteri*,  
*A. sphenisu*.

#### Super-order 3. Palaeognathae

1. Walking birds. No teeth. Wings reduced. Flightless.
2. Coracoid and lower scapula small, usually fused.

##### Order 1. Struthioniformes

1. Flightless, terrestrial and sternum without keel.
2. Pubic symphysis present. Feathers without aftershfts.  
Ex. Ostriches (*Struthio*).

##### Order 2. Casuariformes

1. Flightless, terrestrial and sternum unkeeled. 3 front toes on each foot.
2. Wings small. Neck and body densely feathered.  
Ex. Cassowaries (*Casarius dromocilus*) and Emus (*Dromaius*).

##### Order 3. Aepyornithiformes

1. Flightless. Sternum short, broad and unkeeled.
2. Wings vestigial. 4 toes.  
Ex. Extinct elephant bird (*Aepyornis*).

##### Order 4. Dinornithiformes

1. Flightless, terrestrial. Sternum reduced and unkeeled.
2. Coracoid, scapula and wing bones reduced or absent.
3. Hind limbs massive. 3 or 4 toes.  
Ex. Extinct moas (*Dinornis*).

##### Order 5. Apterygiformes

1. Flightless, terrestrial. Bill long and slender.
2. Wings degenerated. Humerus vestigial. Feathers with large aftershfts.  
Ex. Kiwis (*Apteryx*).

##### Order 6. Rheiformes

1. Flightless, terrestrial and sternum unkeeled.
2. Head and neck partly feathered. Feathers lack aftershft.  
Ex. Rheas (*Rhea*).

##### Order 7. Tinamiformes

1. Sternum keeled. Tail short. Pygostyle reduced.
2. Wings short, rounded and developed for flight.  
Ex. *Tinamus*, *Rhynchus*.

#### Super-order 4. Neognathae or Carinatae

1. Modern birds. New jaw formed by beak without teeth.
2. Sternum keeled. Wings well-developed.

**Order 1. Gaviiformes**

1. Legs short. Toes fully webbed. Patella reduced.
2. Tail has 18-20 stiff feathers. Flight swift. Ex. Loons (*Gavia*).

**Order 2. Podicipediformes**

1. Tail tuft of downy feathers.
2. Legs far back on body. Feet lobed.  
Ex. Grebes (*Podiceps*, *Podilymbus*).

**Order 3. Procellariiformes**

1. Nostrils tubular. Bill covered by horny sheath.
2. Plumage compact, oily in texture.  
Ex. Albatrosses, Fulmars, and Petrels. *Diomedea*, *Oceanodroma*.

**Order 4. Pelecaniformes**

1. All 4 toes included in footweb.
2. Nostrils vestigial or absent.  
Ex. Pelicans, Cormorants, Boobies and Gannets. *Pelecanus*, *Phalacrocorax*, *Sula*, *Moras*.

**Order 5. Ciconiiformes**

1. Long-necked and long-legged wading birds.
2. Decorative plumes. Bill abruptly decurved.  
Ex. Herons, Storks, Ibises and Flamingo. *Ardea*, *Butorides*, *Egretta ciconia*, *Phoenicopterus*.

**Order 6. Anseriformes**

1. Bill broadened with horny ridges.
2. Tongue fleshy, legs short and feet webbed. Ex. Ducks, Geese and Swans. *Anas*, *Anser*, *Cycymas*, *Aythya*, *Brent*.

**Order 7. Falconiformes**

1. Bill stout, hooked at tip with soft naked skin (cere) at base.
2. Feet adapted for grasping with sharp curved claws.  
Ex. Vultures, Kites, Hawks, Falcons and Eagles. *Athartia auria*, *oragyps*, *Neophoros*, *Nephoros*, *Porenopteris*, *Milvus*.

**Order 8. Galliformes**

1. Bill short, feathers with aftershaft.
2. Feet usually adapted for scratching and running.  
Game birds.  
Ex. Grouse, Quail, Pheasants, Turkeys. *Gallus*, *Lagopus*, *Opisthoconus*, *Francollinus*, *Centropus*, *Pavo cristatus*.

**Order 9. Gruiformes**

1. Feathers with aftershaft.
2. Weak or strong flight.  
Ex. Games, Rails and Coots. *Rallus*, *Fulica*, *Gollinula*, *Porphyrion*, *Antigone*, *Anthropoides* and *Gus canadiensis*.

**Order 10. Diatrymiformes**

1. Bill huge. Wings atrophied.
2. 4 toes on each feet.  
Ex. *Diatryma* (extinct).

**Order 11. Charadriiformes**

1. Toes webbed.
2. Plumage dense and firm.  
Ex. Shore birds, Waders, gulls. *Charadrius vociferous*, *Capella*, *Larus*, *Philohela*, *Erolia*.

**Order 12. Columbiformes**

1. Bill short and slender.
2. Tarsus shorter than toes. Crop producing pigeon milk for young ones.  
Ex. Pigeons and Doves. *Columba livia*, *Columba fasciata*, *Ectopistes*, *Zenaidura*, *Crocopus* and *Streptopelia*.

**Order 13. Cuculiformes**

1. Toes 2 in front and 2 behind.
2. Feet not adapted for grasping. Tail long. Bill moderate.  
Ex. Cuckoos. *Coccyzus*, *Cuculus*, *Eudynamis*.

**Order 14. Psittaciformes**

1. Beaks stout, narrow, sharp-edged and hooked.
2. Plumage brilliant green blue, yellow or red.  
Ex. Parrots and Parakeets. *Psittacula*, *Rhynchopsitta*, *Pachyrhyncha*.

**Order 15. Strigiformes**

1. Head large and rounded.
2. Eyes large and directed forwards. Nocturnal.  
Ex. Owls. *Tyto alba*, *Bubo bubo*, *Otus*, *Nyctea*, *Scandiaca*.

**Order 16. Caprimulgiformes**

1. Bill small and delicate.
2. Legs and feet small. Weak and adapted for grasping.  
Ex. Goatsuckers, Nightjars. *Antrostomus*, *Phalaenoptilus*.

**Order 17. Apodiformes**

1. Smallest birds. Legs very short and feet very small.
2. Bill small and weak.  
Ex. Humming birds and Swifts. *Chaetura*, *Adagica*, *Micropus*.

**Order 18. Colliformes**

1. Small passer like.
2. First and fourth toes reversible. Tail very long.  
Ex. Colies (mouse birds). *Colius*.

**Order 19. Trogoniformes**

1. Bill short and stout with bristles at base.
2. Plumage brilliant green.  
Ex. Trogons (*Trogon aleggans*), *Pharomacrus*.

**Order 20. Coraciiformes**

1. 3rd and 4th toes fused at base.
2. Bill strong.  
Ex. King fishers, Hornbills. *Megaceryle*, *Merops*.

**Order 21. Piciformes**

1. Bill stout owl-like.
2. Dig insect and larvae out of wood.  
Ex. Woodpeckers, Facamars, Puffbirds, Barbets, Honey guide and Toucans. *Upupa epops*, *Picus*.

**Order 22. Passeriformes**

1. Perching birds. Toes 3 in front, 1 behind.
2. Includes great majority of all known birds.  
Ex. Crows, Horned Larks, Swallows, Gous, Sparrows, Finches, Starlings, Pipits, Blackbirds, Wood warblers, Tenagers, Wax-wings and Kinglets. *Passer domesticus*, *Molpastes*, *Kittacina*, *Acridotheres*, *Corvus*, *Motacilla*, *Hirundo*, *Ploceus* and *Urolowcha*.

## CLASS AVES (BIRDS)

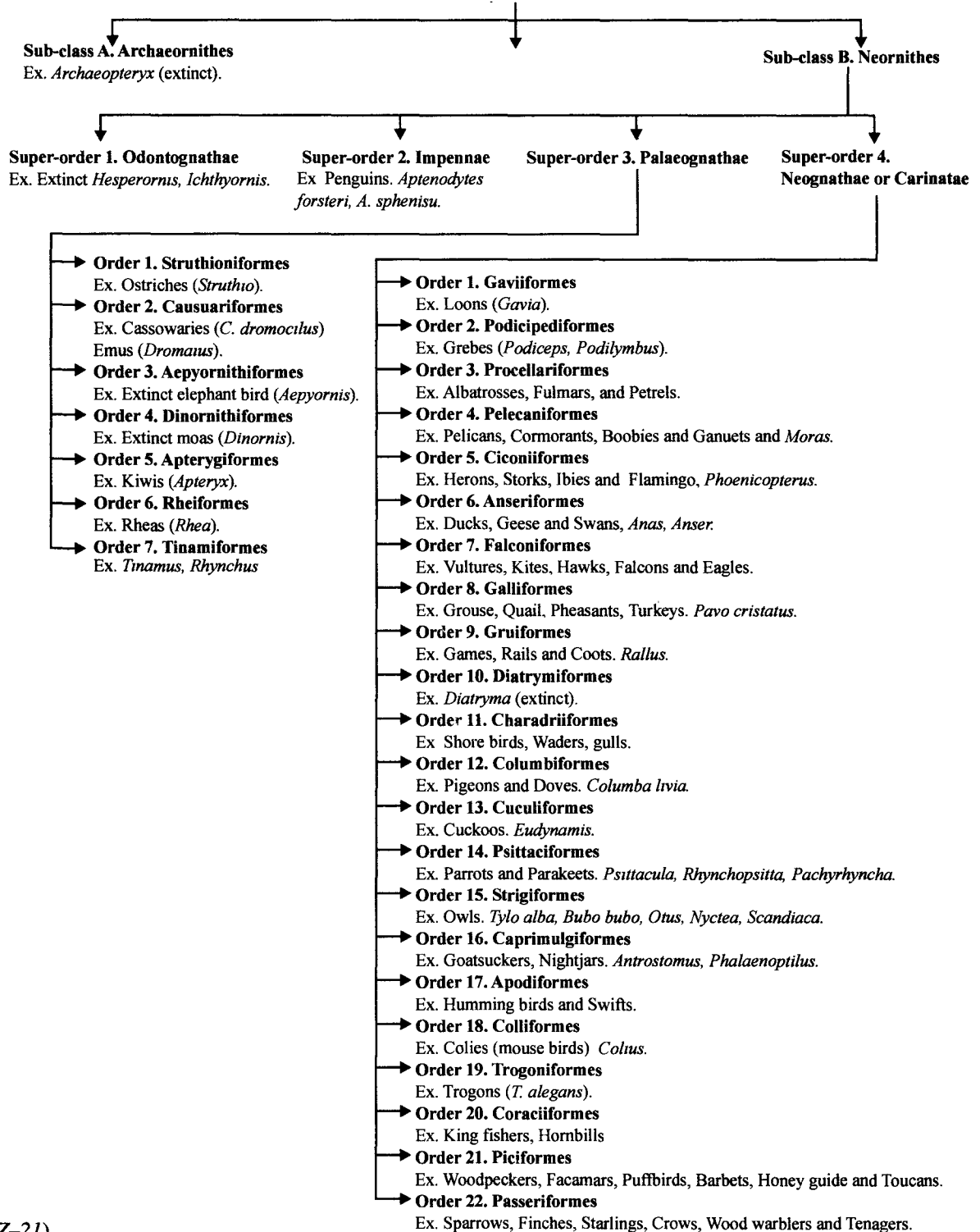

## 117. *Phoenicopterus* : Flamingo

### Classification :

Phylum.....	Chordata	→	Dorsal tubular nerve cord, notochord and gill-slits present.
Group.....	Craniata	→	Definite head. Cranium with head present.
Subphylum.....	Vertebrata	→	Vertebral column present.
Division.....	Gnathostomata	→	Jaws and paired appendages present.
Superclass.....	Tetrapoda	→	Paired limbs, lungs, cornified skin and bony skeleton.
Class.....	Aves	→	Biped and feathered vertebrates.
Sub-class.....	Neornithes	→	True birds. Metacarpals fused.
Superorder.....	Neognathae	→	Modern birds, no teeth, sternum keeled.
Order.....	Ciconiiformes	→	Long legged and long necked wading birds.
Genus.....	<i>Phoenicopterus roseus</i>		

**Geographical distribution :** *Phoenicopterus* is found in Afganistan, India, South France, East Africa, South Spain, West Siberia, and Sri Lanka. It is tropical and sub-tropical. Eocene to Recent.

**Habit and habitat :** It is found in flocks on shallow jheels, and tidal mudflats, ponds and lakes. The flocks consist of many hundreds of individuals. The birds wade into shallow water and feed with their head immersed. They feed on small molluscs, crustaceans, insect larvae, worms, seeds of marshes and organic ooze. It flies rapidly and can swim in water.

### Comments :

- (1) Commonly called as Flamingo called **Bog Hans** or **Raj Hans** in Hindi. Body divided into **head, neck, back and breast.**
- (2) It is a pale, **rosy-white** bird, 1.25 meter tall, with **elongated pink legs** and **long sinuous neck**, which are extended during flight.

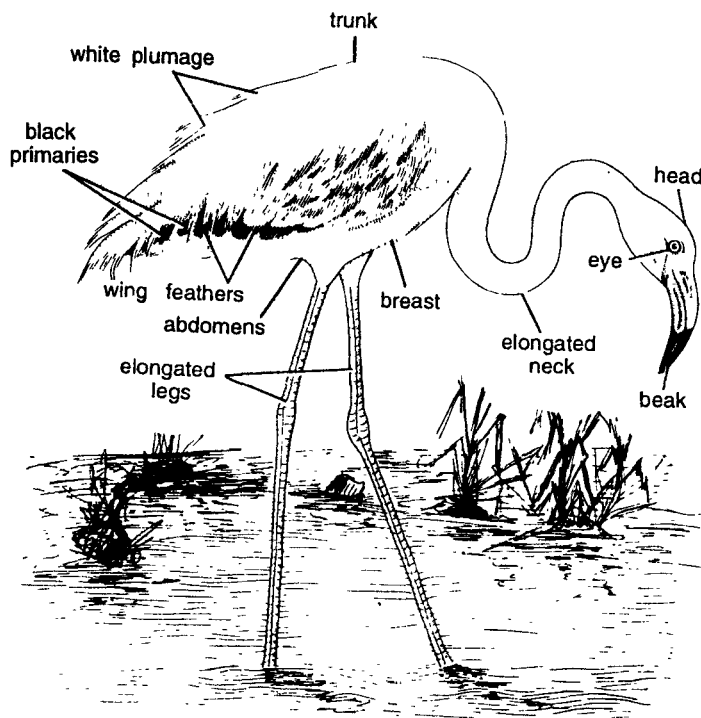

Fig. 117. *Phoenicopterus* : Flamingo.

- (3) The **white plumage** contrasts with scarlet wing coverts and **black primaries**.
- (4) **Head** contains eyes and beak. The large pink bill is down curved. The **fleshy tongue** works like a plunger.
- (5) **Web** present between toes. Wing feathers on back.
- (6) Many nests are formed in colonies on mud flats in tropical brackish water. Eggs are unspotted.

**Special features :** When at rest flamingos usually stand on one leg with the long neck coiled around and the head tucked away under the feathers of the back. The Raj Hans or Bog Hans is famous for its beautiful, majestic and gracious walk.

**Identification :** Since the bird has elongated legs with webbed toes and all above features, hence it is **Flamingo**.

### 118. *Gyps bengalensis* : Vulture

**Classification :** Same as in *Phoenicopterus* (upto Super-order).

Order.....Falconiformes → Bill stout and hooked at tip.

Genus.....*Gyps*

Species.....*bengalensis*

**Geographical distribution :** *Gyps* has cosmopolitan distribution. Eocene to Recent.

**Habit and habitat :** It is found throughout India in all types of places except humid forests. It lives singly or in gatherings or rabbles. It feeds on a variety of animals.

**Comments :**

- (1) Commonly called as **Gidh** in Hindi.
- (2) It is dirty, blackish brown and repulsive-looking bird with massive body, very graceful and majestic when soaring and circling high up in the sky.
- (3) **Flight is strong.** White lower back visible when the bird is at rest or banks in flight. Body is divided into **head, neck, back** and **breast** and **abdomen**.
- (4) **Head** is naked and contains **large eyes**, beak or bill. Behind head is short neck.
- (5) **Bill stout, hooked** at the tip with soft **naked** cere at its base. Mandible sharp edged. Beak adopted for tearing muscles from dead animals.

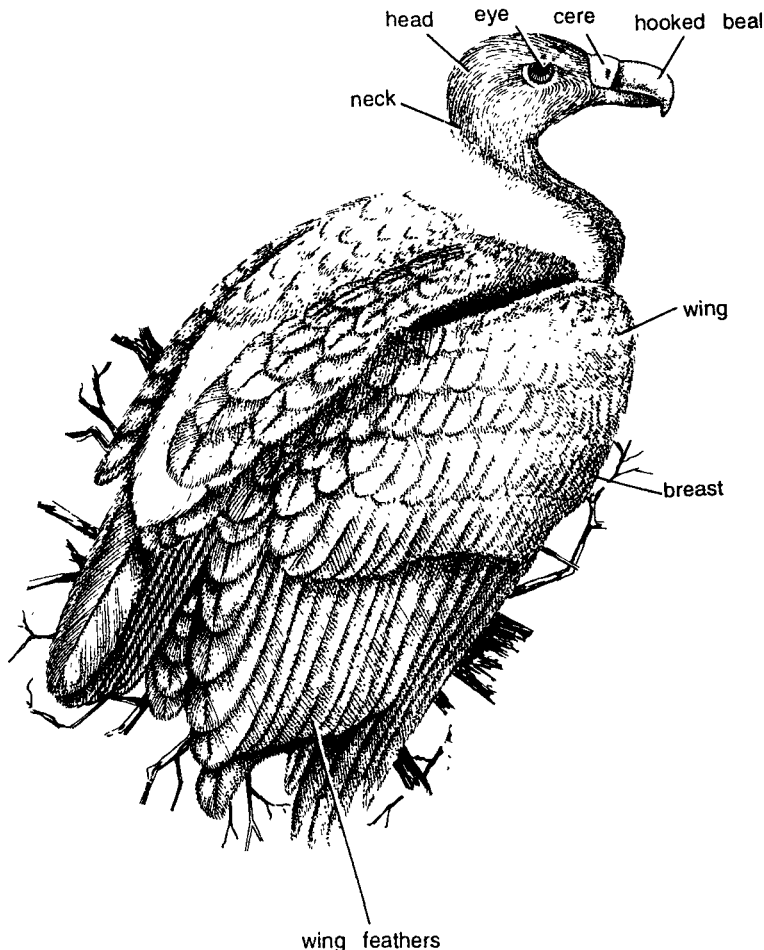

Fig. 118. *Gyps bengalensis*.

- (6) Feet usually adapted for grasping with sharp claws.  
 (7) Vultures nest in large trees near the road or village sides. At rest wings are folded over the trunk.

**Special features :** Vultures are famous for their **keen sight** and they are of greatest **usefulness** to mankind as **scavengers**. Whenever their keen eyes detect a carcass, a large number of these birds collect from all sides and dispose off the flesh of the dead animal within a short period. It is difficult to drive them away. They make peculiar voice while gathering.

**Identification :** Since this bird contains hooked beak, white back and above features, hence it is *Gyps*.

### 119. *Pavo cristatus* : Peacock

**Classification :** Same as in *Phoenicopterus* (upto Super-order).

Order..... Galliformes → Bill short, feathers with after shaft.

Genus..... *Pavo*

Species..... *cristatus*

**Geographical distribution :** Found in various localities of India. Eocene to Recent.

**Habit and habitat :** It inhabits dense scrub, jungle and forest, well provided with rivers and streams. They are shy birds. They feed on grains and vegetable shoots and often do severe harm to newly sown seeds. They also eat small reptiles and insects. It makes nests on ground.

**Comments :**

- (1) Commonly called as **pea-fowl** or **peacock**. In Hindi it is called as **Mor** or **Mayur**.
- (2) It displays a well-marked **sexual dimorphism**.
- (3) Body divided into **head, neck, back, breast** and **abdomen**.
- (4) Head contains beak and eyes.
- (5) **Male** bird is **beautifully pigmented** with **fans-shaped crest; brilliant metallic blue head, neck and breast;** with long trailing bronze green **upper tail coverts** ending in shining blue green purple bronze 'eyes' or ocellate.
- (6) Tail measures 1.5 meters in length.
- (7) Female is duller having lower neck metallic green instead of blue as in male, and lacks the ornamented tail.
- (8) Feet adapted for **scratching** and **running**. Hind legs contain **spur**.

**Special features :** The dance of the peacock with its **gorgeous tail coverts** spread like a **fan** is very famous. It **dances** especially on a cloudy and rainy day. It also produces ugly shrieking sound may-awe in morning, evening, moonlight and on cloudy days. **It is the national bird of India.**

**Identification :** Since this bird has characteristic feathers with eyes and above features, hence it is *Pavo cristatus*.

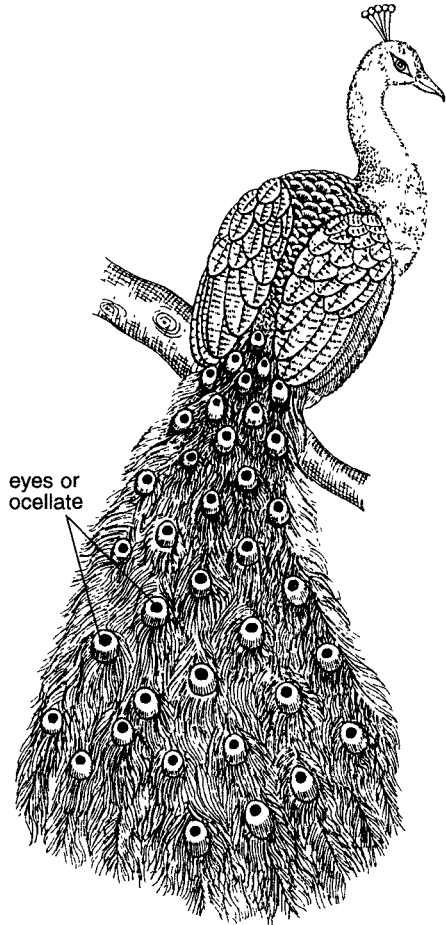

Fig. 119. *Pavo cristatus*.

## 120. *Columba livia* : Pigeon

**Classification :** Same as in *Phoenicopterus* (upto Super-order).

Order..... Columbiformes → Bill short and slender.

Genus..... *Columba*

Species..... *livia*

**Geographical distribution :** *Columba* is commonly found in India, forested zone of the Pacific coast and United States. Eocene to Recent.

**Habit and habitat :** *Columba livia* is the most common and familiar bird around man, nesting in buildings, old houses, warehouses, sheds and railway stations. Their flight is swift and strong. Breeding continues throughout the year.

**Comments :**

- (1) Commonly called as blue-rock pigeon and **Kabutar** in Hindi.
- (2) Body is divisible into **head, neck, back and breast** and abdomen.
- (3) **Plumage** is grey with glistening **metallic green** and purple on breast and neck.
- (4) **Head** contains **large eyes** and **slit-like nostrils**. It is produced into a short and slender **bill** or **beak**. Upper and lower beaks are covered by the horny sheath, called **rhamphotheca**. At the base of the upper beaks there is a patch of skin called **cere**.
- (5) Beak adapted for seed-eating.
- (6) **Eyes** are large, rounded, with a well-developed nictitating membrane and a rounded pupil.
- (7) **Forelimbs** are modified into **wings** which contain besides skeleton flight feathers called as remiges. Feet are covered with **epidermal scutes** formed by the fusion of several reptilian epidermal scales.

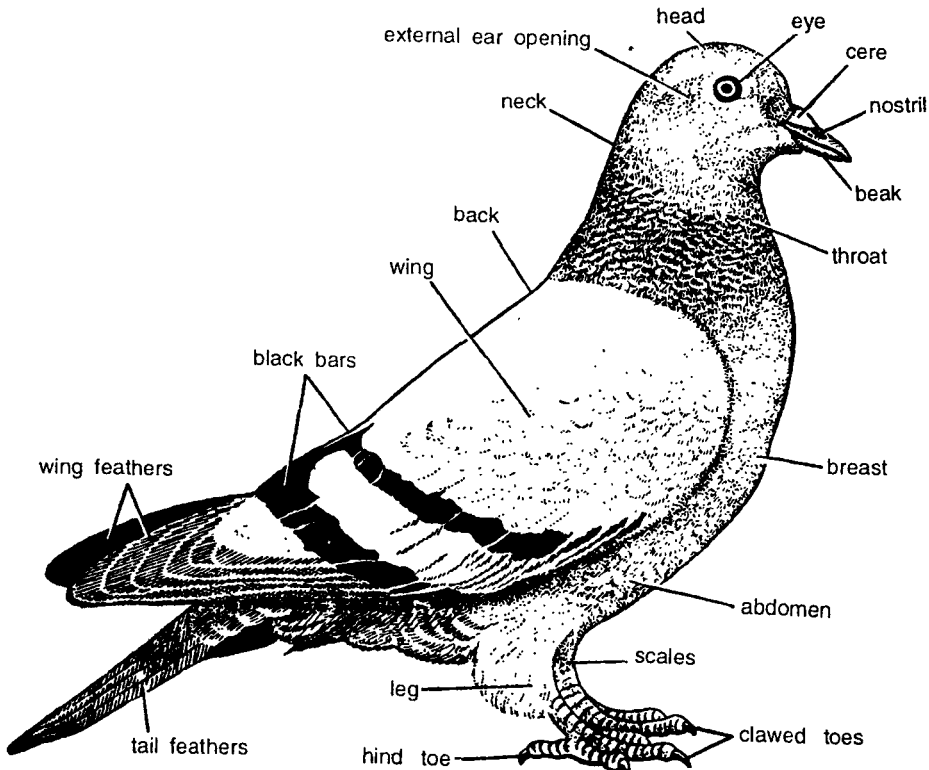

Fig. 120. *Columba livia*.

- (8) **Hind limbs** are modified for **bipedal** locomotion. Tarsus usually shorter than toes. Wing feathers, tail feathers present. Other structures seen are neck, breast, abdomen and black bars on wings.
- (9) Eggs white and unmarked.

**Special features** : Pigeons are the most common domesticated birds, which were in olden times used as **messengers**. They are also eaten by man. Their call notes are very familiar to man as *gootr-goon, gootr-goon*. Pigeons serve as an excellent example for **artificial selection** of **Darwins theory of evolution** as various varieties have been produced by man. Crop large, producing 'pigeon milk' to feed small young.

**Identification** : Since this bird has slaty grey plumage and above features, hence it is *Columba livia*.

## 121. *Psittacula euparia* : Parrot

**Classification** : Same as in *Phoenicopterus*.

Order..... Psittaciformes

Genus..... *Psittacula*

Species..... *euparia*

**Geographical distribution** : *Psittacula euparia* is found in India, Pakistan, Myanmar, Sri Lanka and the United States. Eocene to Recent.

**Habit and habitat** : It is found on tall trees in flocks in city as well as in villages. It is also commonly found in the fruit trees, ripe crops and in jungles. Gregarious with loud voices. Feeds on fruits and crops.

**Comments** :

- (1) Commonly called as **Indian parakeet or parrot**. Its Hindi name is **Hiraman tota**.
- (2) It has **brilliant blue-green plumage** with massive, deeply-hooked **red bill** and a distinct maroon patch on each shoulder. *P. krameri* has no shoulder patches, while *P. cyanocephala* has a bluish-red head and maroon shoulder patches.
- (3) Body is divisible into head, neck, back, breast and abdomen. Head contains eye, nostril and horny beaks.
- (4) **Beak** stout, narrow, sharp edged and hooked at the tip and adapted for **fruit eating**.
- (5) Upper mandible movable on frontal bone of skull. It is so articulated that its lowering automatically raises the upper beak, which is curved at the tip.
- (6) **Feet** adapted for **grasping, holding and climbing**. Foot **zygodactylous** in which I and IV digits are directed backwards and II and III forward to provide a firm grip on the branch of the tree.
- (7) **Tail feathers** elongated. **Maroon patches** on wing feathers.
- (8) **Flight** is graceful and voice powerful.

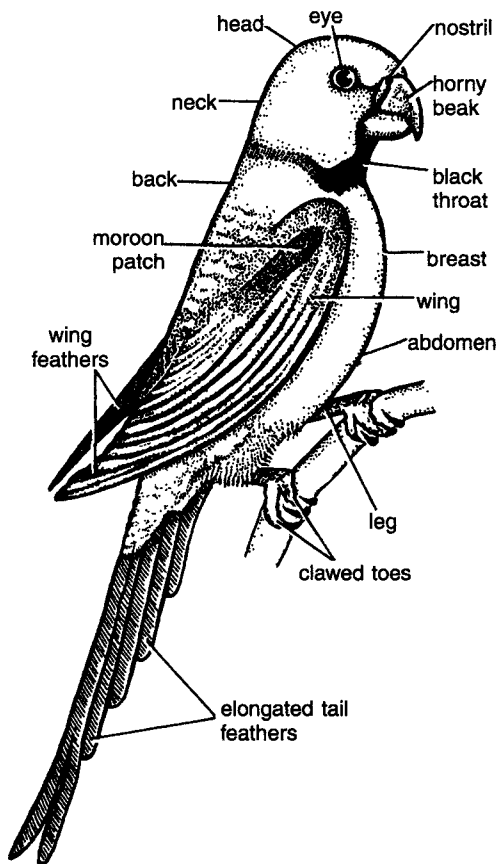

Fig. 121. *Psittacula euparia* : Parrot.



- (9) Female is green all over, but the male has a rose **pink** and **black neck collar** ring.  
 (10) **Nesting** season December to April.

**Special features** : Parrot is a popular domesticated cage bird, found almost in every home and it copies and **speaks** some words like man. It is a serious **agricultural pest** to the cultivators and food growers. It causes enormous harm to standing crops and ripening orchard fruits. It eats maize, pulse, groundnuts and sometimes does considerable damage in newly sown fields. Its voice is sharp, well familiar and screaming *kee-ak, kee-ak, kee-ak, kee-ak*.

**Identification** : Since this bird has green plumage and all above features, hence it is *Psittacula*.

## 122. *Bubo bubo* : Horned Owl

**Classification** : Same as in *Phoenicopterus* (upto Super-order).

Order..... Strigiformes → Head large and rounded.

Genus..... *Bubo*

Species..... *bubo*

**Geographical distribution** : *Bubo bubo* has world-wide distribution, specially found in India, Pakistan and Myanmar.

**Habit and habitat** : *Bubo bubo* is a nocturnal bird, living in woody places and avoids heavy forests. It feeds on small mammals, rodents, birds, lizards and other animals. It hides in retreat in day.

**Comments** :

- (1) Commonly called the **great horned owl**. In Hindi it is known as **Ghughu or ulloo**.
- (2) It is a **fierce looking** large owl with large rounded **head**, huge orange gold **eyes** and **long horns or ears** and **nostril**. **Plumage** soft textured.
- (3) Body divided into **head, back, neck, breast** and **abdomen**.
- (4) **Bird** is heavily built with dark brown **back** mottled and spotted with buff. The dark brown underside is streaked. Beak is short, sharp and curved and adapted for tearing and piercing.
- (5) **Eyes** are large, yellow and forwardly directed, each in a disk of radial feathers. Wings folded over the body.
- (6) **Ear** opening large, often with flap-like cover, sometimes asymmetrical.
- (7) Legs are fully feathered. Feet adapted for **grasping**; **claws** sharp.
- (8) **Nesting** season November to April.

**Special features** : *Bubo bubo* is of great **economic** value to mankind by destroying the harmful animals like rats and mice and these birds need careful protection. Soon after sunset, they produce deep soothing prolonged voice *bubo*. Mythologically owl is considered **unauspicious**. Academically **Barnowl** is very important as Camillo Golgi described **Golgi body** from nerve net of this owl.

**Identification** : Since this bird has large forwardly directed eyes and above features, hence it is *Bubo*.

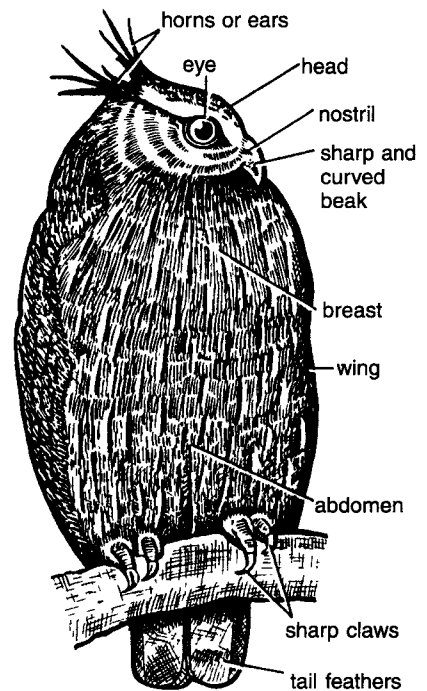

Fig. 122. *Bubo bubo* : Horned owl.

### 123. *Eudynamis scolopaceus* : Koel

**Classification :** Same as in *Phoneicopterus* (upto Super-order).

Order..... Cuculiformes → Toes 2 in front and 2 behind.

Genus..... *Eudynamis*

Species..... *scolopaceus*

**Geographical distribution :** *Eudynamis scolopaceus* is commonly found in India, Pakistan, China, Philippines and Australia.

**Habit and habitat :** It lives on trees of gardens, groves, large leafy trees and their frequent voice *kuoo kuoo* is often heard during mango season. It feeds on banyan and peepul figs, berries, and also insects and caterpillars. The bird has the habit of laying its eggs in the nests of crows and throwing on them the responsibility of raising its young.

**Comments :**

- (1) Commonly called as **Koel**.
- (2) Body divisible into **head, neck, breast** and abdomen.
- (3) Head contains eyes and beak. Beak adapted for seed eating.
- (4) **Sexual dimorphism** is conspicuous. **Male** is black all over having glistening metallic colour with blood red eyes and pale bill. **Female** is brown with **white spots**.
- (5) **Beak** tip pointed and curved downwards. **Eyes** small with rounded pupil. Tail long.
- (6) Hind limbs contain reversible toes with 2 toes in front and 2 toes behind.
- (7) **Wing feathers** folded over the body and **tail feathers** long.
- (8) In summer months the call of male bird is very familiar *kuoo-kuoo-kuoo*. Female does not sing.

**Special features :** Koel amuses the ears of mankind by its beautiful and sweet voice. The poets have often associated koel in their romantic poems. The female nestling Koel is much darker than adult female, an adaptation to deceive foster parents, *i.e.*, crows.

**Identification.** Since this bird has pale bill, red eyes and above features, hence it is male *Eudynamis scolopaceus*.

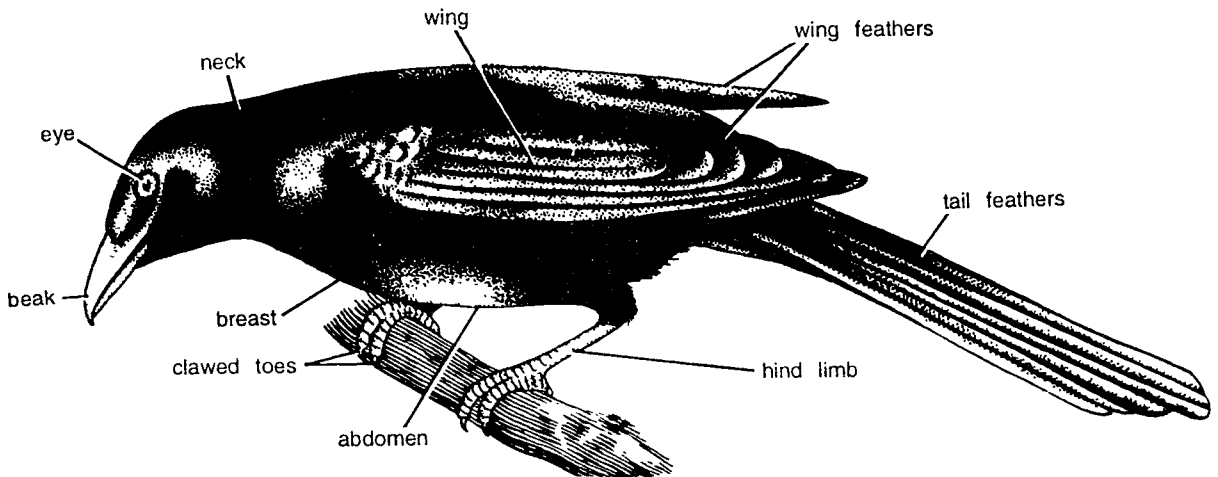

Fig. 123. *Eudynamis scolopaceus* : Koel.

## 124. *Dendrocopus mahrattensis* : Woodpecker

**Classification :** Same as in *Phoenicopterus* (upto Super-order).

Order..... *Piciformes* → Bill stout owl like.

Genus..... *Dandrocopus*

Species..... *mahrattensis*

**Geographical distribution :** *Dendrocopus mahrattensis* is widely distributed in Indian subcontinent. Eocene to Recent.

**Habit and habitat :** The woodpecker is a small bird inhabiting light scrub in countryside, thin forests, mango orchards, groves of trees and other leafy trees. They scuttle up tree trunks and branches, tapping on the bark and peer into the cracks for ants and grubs which are extracted by the help of long worm-like tongue. They produce sharp voice *click, click or click-r-r-r*. It excavates nest cavities by **destroying** the wood itself.

**Comments :**

- (1) Commonly called woodpecker and **Kathphorwa** in Hindi.
- (2) It has the size of a Bulbul. Body divisible into **head, neck, back, breast, abdomen**.
- (3) Head contains eyes and beak.
- (4) **Beak** is long, stout and pointed owl-like with which they destroy wood. Beak adapted for chiseling or wood cutting.
- (5) **Eyes** are large and tongue roughened with barbs near the tip and protrusible.
- (6) **Toes** 2 in front and 2 behind, not reversible.
- (7) Upper **plumage** contains **black and white spots** on wings and tail feather. **Male** has **scarlet patches**.
- (8) Tail is stiff and wedge-shaped. **Tail feathers** with pointed tips.
- (9) It makes **nest** by destroying the wood itself. They live in pairs.

**Special features :** It destroys the tunics of the woody trees.

**Identification :** Since this bird has pointed beak and above features, hence it is *Dendrocopus*.

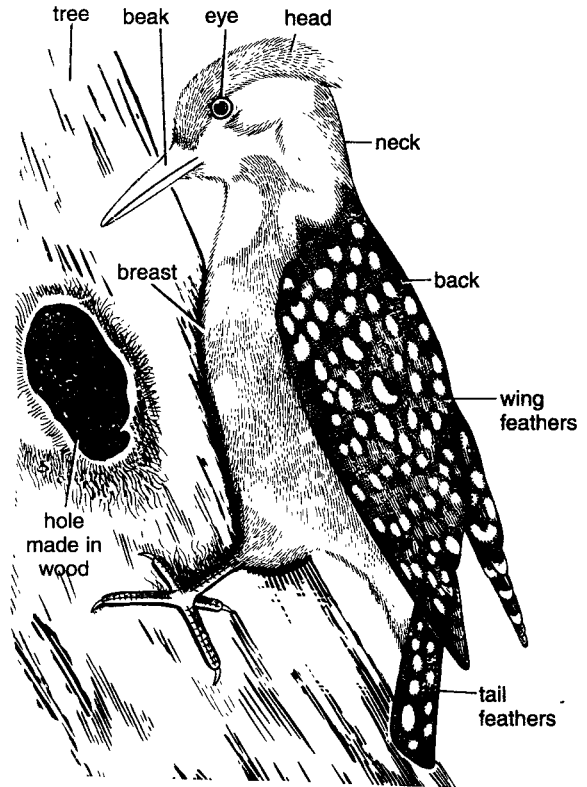

Fig. 124. *Dendrocopus mahrattensis* : Wood pecker.

## 125. *Passer domesticus* : Sparrow

**Classification :** Same as in *Phoenicopterus* (upto Super-order).

Order..... *Passeriformes* → Perching bird. Toes 3 in front and behind.

Genus..... *Passer*

Species..... *domesticus*

**Geographical distribution :** *Passer domesticus* is abundantly found in Sri Lanka, Myanmar, Pakistan and India, and has been introduced to North America, South America, Australia and New Zealand. Eocene to Recent.

**Habit and habitat :** Most familiar companion bird freely moving and nesting in the houses. They act as commensal to man. In winter they feed on cultivated areas in flocks. They are gregarious.

**Comments :**

- (1) It is the common **house sparrow**. Its Hindi name is **Gauriyya**.
- (2) It is a small bird measuring 10 to 16 cm in length. Body divisible into **head, neck, back, breast and abdomen**. Head contains **eyes and beak**.
- (3) Sexual dimorphism is distinct. **Female is ash white**, while male is earthy brown with blackish throat and breast and white abdomen.
- (4) **Eyes** small and the **beak** is short and conical. Beak adapted for seed eating.
- (5) Breast and abdomen bulding.
- (6) **Wing** and **wing feathers** folded over body. **Tail feathers** elongated.
- (7) **Feet** adapted for **perching**. Toes 3 in front and 1 behind.
- (8) **Nesting** practically throughout the year. Some make elaborate nests; lay 3-8 eggs.
- (9) Young naked and blind at hatching, require feeding and care by parents before becoming independent.
- (10) Very familiar house hold bird.

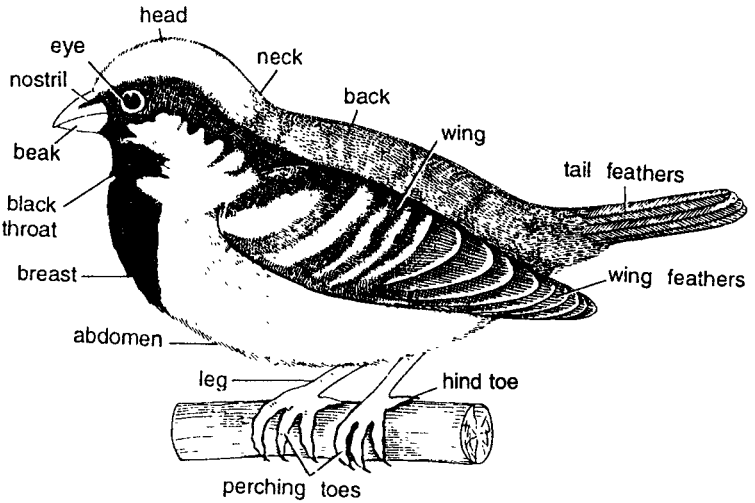

Fig. 125. *Passer domesticus* (Sparrow), Male.

**Special features :** The sparrows are both **useful and harmful** to mankind. They destroy several agricultural pests. They destroy vegetable and flower buds.

**Identification :** Since this bird has earthy brown body and above features, hence it is male *Passer domesticus*.

## 126. *Corvus splendens* : Crow

**Classification :** Same as that of *Passer domesticus*.

Genus..... *Corvus*

Species..... *splendens*

**Geographical distribution :** *Corvus splendens* is found everywhere in India.

**Habit and habitat :** It is the most common, most familiar, most intelligent and boldest bird, living on trees in towns, villages and gardens. It feeds on any thing from dead meat to any eatable left on the table, i.e., bread, butter, fruits and other preparations. Always around human habitat.

**Comments :**

- (1) Common house crow, called **Koowa** or **Cag** in Hindi.
- (2) Adult crow 32 to 42 cm in length.
- (3) Body divisible into **head, neck, back, breast and abdomen**. Head contains eyes and beak. Beak adapted for tearing and cutting.
- (4) **Neck and breast** are grey, but back and **plumage** are glossy black.
- (5) **Eyes** are large and beak stout and elongated.
- (6) **Tail feathers** are elongated. **Wing feathers** folded dorsolaterally.
- (7) **Feet** adapted for **perching**, 3 toes in front and 1 behind.
- (8) Young naked and blind at hatching, require feeding and parental care eating rats and dead animals before becoming independent.

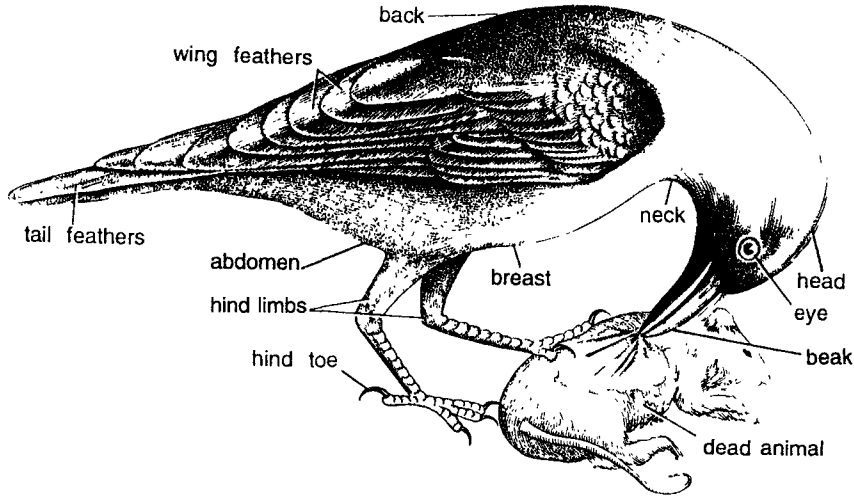

Fig. 126. *Corvus splendens*.

**Special features :** The house crow acts as efficient **municipal scavenger**. It destroys locusts and other injurious insects but it also destroys the crop and fruits in orchards. The house crow builds nests of sticks. They roost communally in large flocks. They are also a menace to the eggs and infants of other birds. Whenever any fellow crow dies, several crows assemble. **It is very intelligent and danger avoiding bird.**

**Identification :** Since the above bird has raised head and above features, hence it is *Corvus splendens*.

## 127. *Archaeopteryx*

### Classification :

Phylum.....	Chordata	→	Dorsal tubular nerve cord, notochord and gill-slits present.
Group.....	Craniata	→	Cranium with brain present.
Subphylum.....	Vertebrata	→	Vertebral column present.
Division.....	Gnathostomata	→	Jaws and paired appendages present.
Class.....	Aves	→	Biped and feathereal vertebrates.
Sub-class.....	Archaeornithes	→	Jaws and wings present.
Genus.....	<i>Archaeopteryx</i> (Model)		

### Comments :

- (1) Fossilized *Archaeopteryx lithographica* was discovered in 1861 from **Bavaria**, Germany. It belonged to Jurrassic period about 140 million years ago.
- (2) Body was divisible into **head, neck, back breast, abdomen** and **tail**. Tail elongated.
- (3) Head contained **eye, nostril** and **toothed beak**. Head, neck and beak like birds.
- (4) Forelimbs modified into **feathers** or **wings**. Wing feathers consisted of **remiges** while tail feathers were made up of **retrices**.
- (5) Whole body was covered with **scales**.
- (6) Hind limb consisted of **tarsometatarsus, hallux** and **clawed toes**.
- (7) Above fossil possessed both reptilian and avian characters.
- (8) **Reptilian features**—(i) Epidermal scales over body, (ii) Simple brain, cylindrical cerebral hemispheres and unexpanded cerebellum, (iii) Jaws with peg like homodont teeth is sockets, (iv) vertebral amphicoelus, (v) sternum poorly developed without keel, (vi) Cervical vertebrae 9-10 and caudal vertebrae 20.

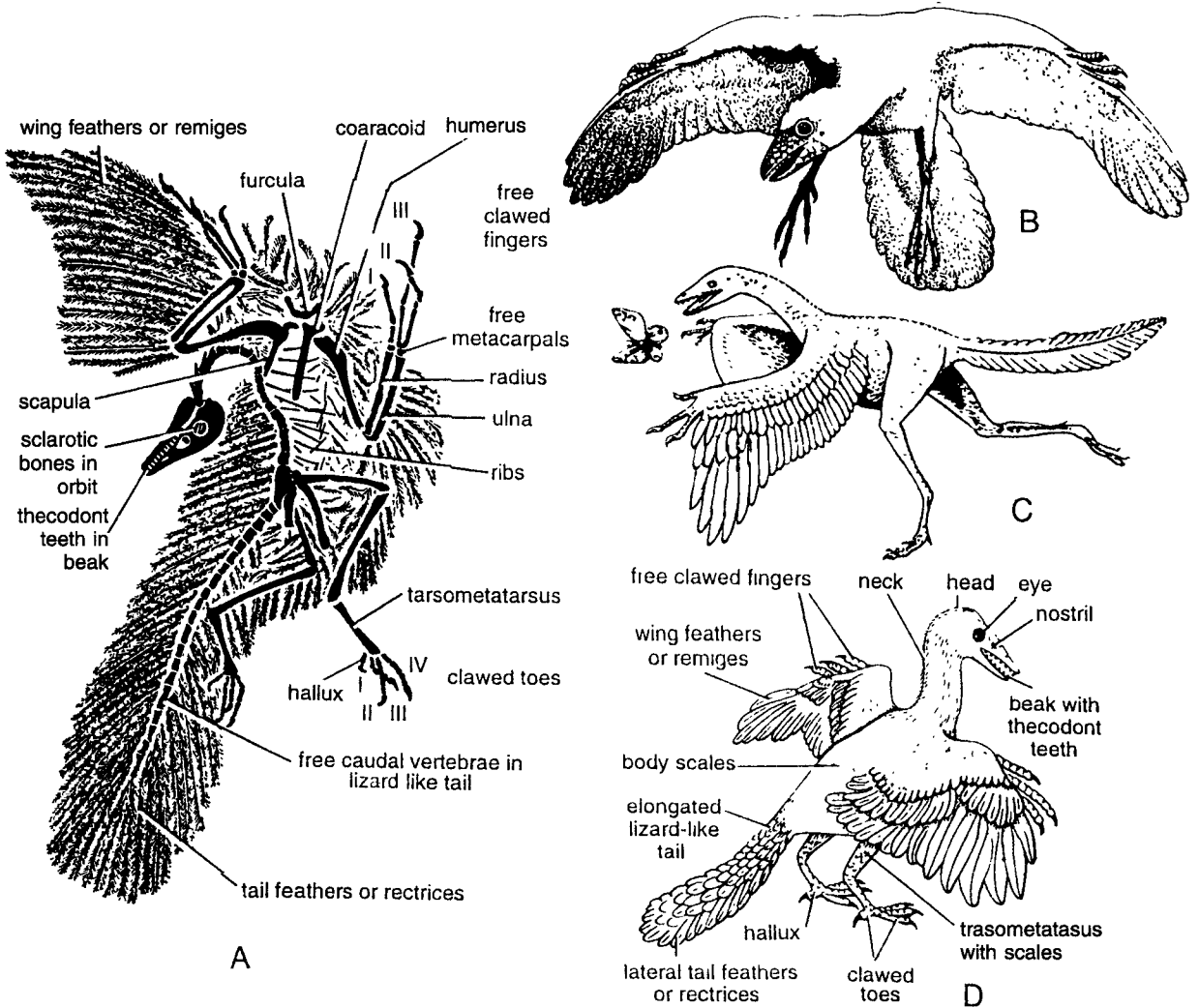

Fig. 127. *Archaeopteryx*. A. Fossil skeleton, B. Reconstruction as arboreal glider, C. Reconstruction as cursorial predator, D. Detailed structure.

- (9) **Avian characters**—(i) Presence of **feathers**, (ii) Jaws like beak, (iii) Skull monocondylic, (iv) Girdles and bones avian, (v) Scapula elongated and curved, (vi) Clavicles fused into V-shaped fercula, (vii) Foot consisted of tarsometatarsus, (viii) Hallux opposable and (ix) Sclerotic ossicles are present in eye.

**Special features** : *Archaeopteryx* is excellent example of connecting link between reptile and birds. It gives definite examples regarding **origin of birds**.

**Identification** : Since the animal has beak with and all above features, hence it is *Archaeopteryx*.

## 128. Types of Beaks in Birds

The entire modern avian world is characterized by the absence of teeth. The upper and lower jaw bones become elongated to form a peculiar **beak** or **bill** covered by a horny sheath called as **rhamphotheca**. The modification of forelimbs into wings deprived birds of some of their normal functions. Beak serves both as mouth and hand. The diversity of form of beaks is mainly related to the type of food eaten and to the manner of feeding. Birds exhibit almost indefinite variations in shape, size and structure of beaks, of which only some of the most important and common types are described here.

1. **Seed-eating beak** : Short, stout, peg-like and conical beaks are characteristic of small grainivorous or seed eating birds, such as **sparrows**, [Fig. 128/(1)] **finches** and **cardinals**. The weaker beaks are used for **piercing up small seeds**, while more powerful beaks are meant for crushing large and hard-shelled seeds and fruit stones.
2. **Cutting beak** : Birds such as jungle **crows**, [Fig. 128 (2)] possess long and slender beaks with cutting edges which can be used variously for cutting plants.
3. **Fruit-eating beak** : In **parrots**, [Fig. 128 (4)] the beak is sharp, massive, deeply hooked and extremely strong. It is well adapted for gnawing or breaking open hard seeds and nuts, which form their staple diet.  
Enormous beak of **hornbills**, [Fig. 128 (3)] looking so heavy and cumbersome, is really quite light as its interior is of a cellular structure. It is suggested that these cells act as resonators, thus enabling the bird to produce its exceptionally loud cry.
4. **Insectivorous beak** : In **swallows Robin** [Fig. 128 (6)], **Frog-mouth** [Fig. 128 (7)] and **swifts**, the beak is small, wide and delicate to **scoop** up their living insect prey while on wing. In **fly catchers**, the beak is short but strong, with mandibles notched at the tip and beset with numerous rictal bristles at the base.
5. In **hoopoe**, [Fig. 128 (5)] the beak is long, slender and slightly curved and meant for turning the leaves or probing into the soil for insect grubs and pupae, etc.
6. **Wood-chiseling beak** : **Woodpeckers** [Fig. 128 (8)] have elongated, straight and stout chisel-like beaks for drilling into the barks or wood for insect larvae or for nest construction. They have thickened, shock-absorbent skull bones and strong neck muscles to make such pounding feasible.
7. **Tearing and piercing beak** : **Carrion-feeding** and **flesh-eating** birds, such as **vultures**, [Fig. 128 (10)] **hawks**, **eagles**, [Fig. 128 (11)] **owls** [Fig. 128 (12)] and **kites** etc., have short, pointed, sharp-edged and powerful, hooked beaks for tearing flesh and operated by well-developed mandibular muscles.
8. **Mud-probing beak** : Familiar examples of **mud-probing beaks** are found in **snipe**, **stilt**, [Fig. 128 (13)] **sand-piper**, **Yellow leg** [Fig. 128 (9)], **Kiwi** [Fig. 128 (19)] **jacana** and **lapwing**, etc. Their beaks are extremely long and slender and are used as a probe for thrusting far down into water and mud in search of worms and larvae. Some of these birds are remarkable for the slenderness and extreme length of their beaks.
9. **Water and mud straining beak**. In **ducks** : [Fig. 128 (18)] **teals** and **geese**, the beak is broad and flat. The edges of the jaws are furnished with horny serrations or transverse lamellae, which act as a **sieve** or **strainer**, letting the water and mud pass out while retaining the **food** in the mouth. Such a beak enables the bird to avail itself of the rich store of food in the shape of insects and other organism. In **flamingoes**, [Fig. 128 (17)] the beak is distally curved downwards and likewise furnished with shifting lamellae. The two halves of lower jaw are considerably enlarged so that the comparatively narrow upper jaw closes upon a wide cavity.
10. **Fish catching beak**. **Storks**, **herons** and **kingfishers** [Fig. 128 (15)] have long, powerful and sharply-pointed **spearing beaks** to **capture** fish, frogs, tadpoles and similar aquatic animals. **Cormorants** [Fig. 128 (14)] have long and narrow beaks, the edges of which are armed with sharp backwardly

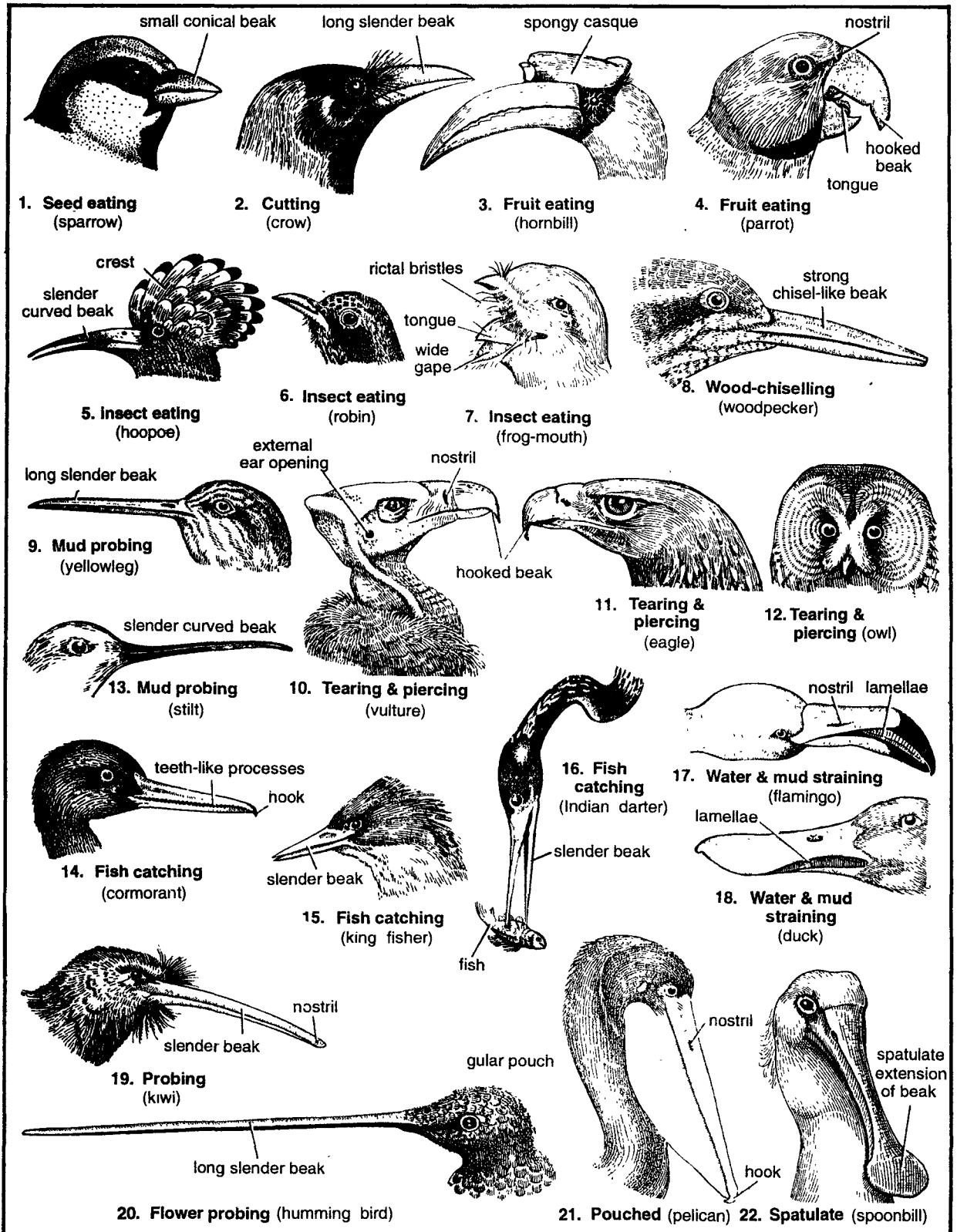

Fig. 128. Kinds of beaks in birds.



directed, tooth-like processes meant for capture of fish. In **snake-birds** or **Indian darters**, [Fig. 128 (16)] these serrations take the form of fine needle-like points.

11. **Spatulate beak** : **Spoonbill** possesses a very specialized form of beak. It is flattened throughout its length but terminates in a broad, **spatulate** [Fig. 128 (22)] or **spoon-like** expansion meant for splashing in water and **mud** in search of insects, worms, fish, molluscs and other small animals upon which the bird feeds.
12. **Pouched beak** : **Pelicans** [Fig. 128 (21)] consume enormous quantities of fish. Their beak is large, with a capacious **gular pouch** of extensible skin attached to the lower mandible and serving as a fishing net.
13. **Flower-probing beak** : Long, pointed and rapier-like probing beak of tropical **humming birds** [Fig. 128 (20)] dive down the corollas of flowers for sucking honey and insects. They suspend themselves in mid air before the flowers, while they extract their honey and insects. Their beaks are bent or so shaped so as to suit the particular shape of the flowers.

### 129. Types of Feet or Claws in Birds

The feet of birds are also modified variously in accordance with the character of the environment and the manner of locomotion. For illustration see figure. 129.

1. **Cursorial or running feet** : In **running birds**, the legs are powerful and the number of toes is reduced. Hind toe may be elevated, reduced or absent. In **bustards**, **coursers** and **ratites** such as **emu**, **rhea** and **cassowary**, only 3 toes directed forwards are present. **Ostrich** [Fig. 129 (1)] has only 2 toes, of which the outer one is smaller and without a nail.
2. **Perching feet** : Majority of birds belong to the category of **perching birds** or such as **finche** [Fig. 129 (3)], **sparrows**, [Fig. 129 (2)] **crows**, **bulbuls**, **robins**, **mynahs**, etc. Toes are anterior and slender, while one toe or hallux is posterior, strongly built and apposable, so that they can securely fasten the foot to a branch or a perch.
3. **Scratching feet** : Feet of **fowls**, [Fig. 129 (7)] **quails** and **pheasants**, etc. are stout, with strongly developed claws and well **adapted for running** as well as **scratching** the earth. Foot of male bird is usually provided with a pointed bony spur of offence and defence.
4. **Raptorial feet** : Predatory or carnivorous birds, such as **eagles**, **kites**, **vultures** and **owls**, [Fig. 129 (4)] etc. have strongly taloned feet for **striking** and **grasping** their prey. Toes have strongly developed, sharp and curved claws. Large and fleshy bulbs, called **tylari**, are found on the undersurface of the toes, especially developed in the **sparrow-hawk**. In **osprey** [Fig. 129 (5)] and **Ketupa**, tylari are absent but horny spines are present, which help in gripping slippery preys such as fish.
5. **Wading feet** : Legs and toes are exceptionally long and slender in **wading** or **marshy** birds such as **herons**, [Fig. 129 (11)] **snipes**, **jacana**, [Fig. 129 (6)] **lapwing**, etc. These serve to **walk over** aquatic vegetation or marshes. Web is absent or feebly developed.
6. **Swimming feet** : In **swimming birds**, the **toes** are **webbed**, partially or completely. In diving birds, like **coots** [Fig. 129 (9)] and **grebes**, [Fig. 129 (10)] the web is lobate and the toes are free. In swimming and paddling birds, such as **ducks** [Fig. 129 (12)] and **teals**, **avolet** [Fig. 129 (8)] only the anterior 3 toes are united in a web. In **peican** and **cormorant** [Fig. 129 (13)] all the 4 toes are enclosed in the web.
7. **Climbing feet** : In **parrots** [Fig. 129 (17)] and **woodpeckers** [Fig. 129 (14)] the feet are used as **grasping organs** and especially adapted for **climbing vertical** surfaces. Second and third toes point in front, while the first and the fourth toes point backwards.
8. **Clinging feet** : In **swifts**, **martinets** [Fig. 129 (15)] **kingfisher** [Fig. 129 (16)] and **humming birds**, all the 4 toes point forwards and serve to cling to steep faces of cliffs or under caves of houses, etc.

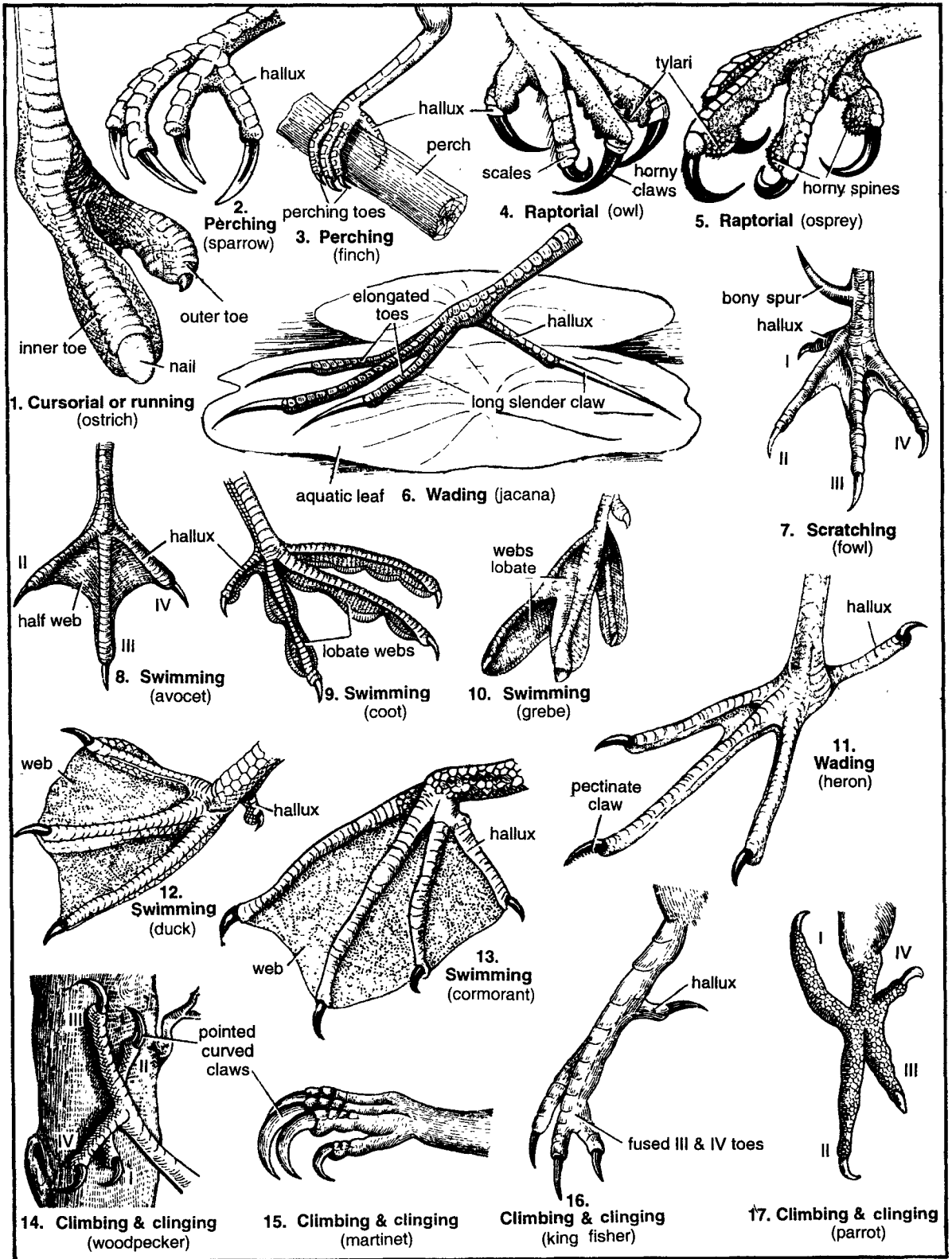

Fig. 129. Kinds of feet or claws in birds.

## CLASS MAMMALIA

### Natural history

Mammals are the highest group in the animal kingdom, comprising moles, bats, rodents, cats, monkeys, whales, horses, deer, elephants and other animals. All are covered with hair or fur and are warm blooded. The term mammal refers to mammary glands males females that supply milk for sucking young. Mammary glands are also found in males in undeveloped condition. Parental care is highly developed. The insulated body covering and complete separation of venous and arterial blood in the heart make the regulated body temperature possible. High rate of metabolism requires large food. Cerebellum and cerebrum provide high degree of co-ordination in all activities.

Various mammals live in all sorts of habitat from polar regions to the tropics, from sea to densest forests and direct deserts. Mammals inhabit all parts of the earth-land, water and air. The walrus and some seals live in the Arctic seas and ice, whales and porpoises in open sea, musk rat and otter live in fresh-water. The grasslands and forests are homes of many rodents, carnivores and hoofed animals. Population density varies with availability of food. Natural crevices, holes, rocks, holes in trees, burrows, tunnels etc., provide shelter for various mammals. Mammals also form good source of animal products industry, i.e., meat, wool and leather are obtained from them. They also provide transport and recreation.

### Expanded classification

#### CLASS MAMMALIA

1. Mammary glands present.
2. Body covered with hairs.
3. 2 occipital condyles.
4. External ear or pinna present.
5. Jaws with differentiated teeth in sockets.
6. Heart 4-chambered.
7. Warm-blooded.

#### Sub-class A. Prototheria

1. Primitive, reptile-like.
2. Egg laying.

##### Order Monotremata

1. Pinna absent. Cloaca present.
2. Teeth in young. Adults with horny beak.
3. Confinated to Australian region.  
Ex. Platypus or Duckbill (*Ornithorhynchus*), Spiny anteater (*Tachyglossus* = *Echidna*).

#### Sub-class B. Allotheria (Extinct).

#### Sub-class C. Theria

1. Marsupials and placental mammals.
2. External ear or pinna present.

#### Infra-class I. Metatheria

1. Pouched and viviparous.
2. With or without rudimental yolk sac placenta.

#### Order Marsupialia

1. Females with marsupium.
2. Uterus and vagina double.  
Ex. *Didelphis*, *Macropus* and *Perameles*.

#### Infra class II. Eutheria

1. Placental mammals.
2. Vagina single.

##### Order 1. Insectivora

1. Snout long and tapered. Teeth sharp, pointed.
2. Feet usually 5-toed.  
Ex. Moles, Shrews. *Talpa*, *Scolopus*, *Erinaceus* and *Sorex*.

##### Order 2. Dermoptera

1. Resemble flying squirrels in appearance.
2. Forelimbs equal and included with tail in a wide, thin, fur-covered parachute (patagium).  
Ex. Flying lemurs. *Cynocephalus* (= *Galeopithecus*).

##### Order 3. Chiroptera

1. Flying mammals.
2. Integumental flight membrane or wing comprises forelimbs, 2nd to 5th digits, hind limbs and tail in some.

##### Sub-order 1. Megachiroptera

1. Sleep by day on tree branches, hanging head downwards with wings folded.
2. Feed on fruits.  
Ex. Flying foxes (Fruit bats). *Pteropus*, *Cynopterus*.

##### Sub-order 2. Microchiroptera

1. Hang by hind claws, head downwards during day.
2. Gregarious or solitary.  
Ex. Insectivorous bats. *Myotis*, *Desmodus* and *Vespertilio*.

##### Order 4. Edentata

1. Teeth reduced to molars in forepart of jaw.
2. Toes clawed.  
Ex. Sloths. *Dasyppus*, *Bradypus*. *Choloepus*.

##### Order 5. Pholidota

1. Body covered by large overlapping plates with sparse hair between.
2. No teeth. Tongue slender for capturing insects.  
Ex. Scaly anteaters (*Manis*).

##### Order 6. Primates

1. Head turns readily on neck.
2. Innermost toe and thumb usually opposable.  
Ex. Monkeys, apes and man.

##### Sub-order 1. Lemuroidea

1. Head without snout.
2. Some toes with claws, others with flat nails. Tail prehensile.  
Ex. Lemur (*Nycticebus*, *Loris*), tree shrew (*Tupaia*).

**Sub-order 2. Anthropoidea**

1. Cranium enlarged. Cerebral hemispheres extend over cerebellum.
2. Eyes directed forwards. Vision binocular.  
Ex. New world and old world monkeys, apes and Man. Squirrel monkey (*Saimiri*), Spider monkey (*Ateles*), Marmoset (*Callithrix*), Rhesus monkey (*Macacca*), Baboon (*Papio*), Langur (*Presbytis*), Gibbon (*Hylobates*), Gorilla (*Gorilla gorilla*), Orangutan, Chimpanzee (*Pan troglodytes*) and Man (*Homo sapiens*).

**Order 7. Rodentia**

1. Gnawing mammals. Incisors chisel-like. No canines.
2. Gap between incisors and cheek teeth.  
Ex. Squirrel (*Funambulus*), Black rat (*Rattus rattus*), White rats (*Albino rats*), Mouse (*Mus musculus*), Porcupine (*Hystrix*), Guinea pig (*Castor*).

**Order 8. Lagomorpha**

1. Diastema and cheek pouches present.
2. Weak temporal muscles.  
Ex. Hare (*Lepus nigricolis*), Rabbit (*Oryctolagus ruficaudatus*).

**Order 9. Carnivora**

1. Small to large carnivores. 5 toes with claws.
2. Canines as fangs. Placenta Zonary.  
Ex. Wolf (*Canis lupus*), Polar bear (*Ursus*), Domestic dog (*Canis familiaris*), Panda (*Allurus*), Common mongoose (*Herpestes mungo*), Lion (*Panthera leo*), Tiger (*leo tigris*), House cat (*Felis domesticus*). Seals (*Phoca*), Fox (*Vulpes*).

**Order 10. Cetacea**

1. Medium to largest size. Body spindle-shaped. Head long pointed, directly joined to body. No neck.
2. Forelimbs paddle-like Digits embedded. No claws.  
Ex. Whales. Blue whale (*Balaenoptera*), Sperm whale (*Physeter catodon*), Porpoise (*Phocaena*), Dolphin (*Delphinus delphis*).

**Order 11. Sirenia**

1. Body spindle-shaped, forelimbs paddle like. Hind limbs absent.
2. No pinna. Muzzle blunt, mouth small, lips fleshy.  
Ex. Dugong (*Dugong dugong*), Manatees (*Trichechus*).

**Order 12. Proboscidea**

1. Massive size, head large, ears broad and flat, neck short and body huge.

2. Legs pillar-like.
3. Nose and upperlip a long flexible muscular probosis with nostrils at tip.  
Ex. Elephants (*Elephas indicus*).

**Order 13. Perissodactyla**

1. Foot with odd number of toes, each ensheathed in cornified hoof. Functional axis of leg passing through middle (3rd toe).
2. Stomach simple.  
Ex. Horse (*Equus*), Tapirs (*Tapirus*), Donkey Ass (*Equus asinus*), Rhinoceros (*Rhinoceros*).

**Order 14. Artiodactyla**

1. Even-toed hoofed mammals. Hoofs cornified. Axis of leg between toes.
2. Antlers or horns on head. Stomach with 4 compartments.

**Sub-order 1. Suiformes**

1. Teeth 38-44. Canines enlarged as curved tusks.
2. Limbs short.  
Ex. Peccaries, Pigs, Warhogs and Hippopotamus. Old world pig (*Sus scrofa*), Wart hog (*Phacochoesus*), New world pig (*Tayassu tajacu*), Hippopotamus (*Hippopotamus amphibius*).

**Sub-order 2. Tylopoda**

1. Feet soft without hoof.
2. Hump present.
3. Stomach with 4 parts.  
Ex. Camels. One-humped Arabian camel (*Camelus dromedarius*), two-humped camel (*Camelus bactrianus*).

**Sub-order 3. Ruminantia**

1. Intermediate between pigs and camels. 34 upper canines present.
2. Stomach with 3 parts.  
Ex. Nilgai (*Bos dophis*), Buffalo (*Bos bubalus*), Cow (*Bos Indian*), Muskdeer (*Moschus*), Chinese water deer (*Hydropotes*), European red deer (*Odocoileus*), Giraffe (*Giraffa camelopardalis*), Mountain sheep (*Ovis canadensis*), Mountain goat (*Oreamnos americanus*), Water buffalo (*Bubalus bubalis*), Antelope.

## CLASS MAMMALIA

## Sub-class A. Prototheria

## Order Monotremata

Ex. Platypus or Duckbill  
(*Ornithorhynchus*), Spiny  
anteater (*Tachyglossus* = *Echidna*).

## Sub-class B. Allotheria (Extinct).

## Sub-class C. Theria

## Infra-class I. Metatheria

## Order Marsupialia

Ex. *Dideiphus*, *Macropus*, *Perameles*.

## Infra class II. Eutheria

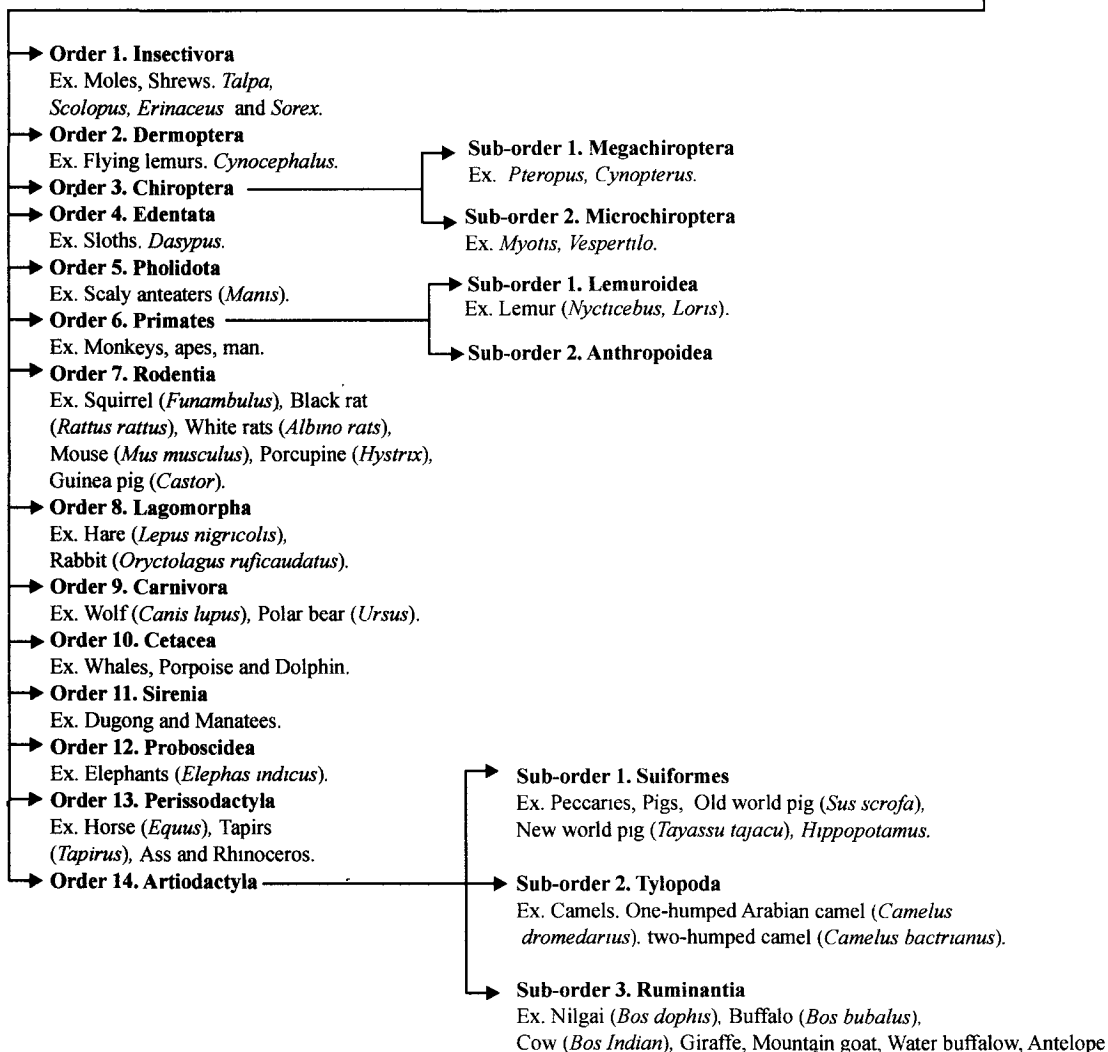

### 130. *Ornithorhynchus* : Duck-bill

#### Classification :

Phylum.....	Chordata	→	Dorsal tubular nerve cord, gill-slits and notochord present.
Group.....	Craniata	→	Definite head. Cranium with brain present.
Subphylum.....	Vertebrata	→	Vertebral column present.
Division.....	Gnathostomata	→	Jaws and paired appendages present.
Superclass.....	Tetrapoda	→	Paired limbs, lungs, cornified skin and bony skeleton.
Class.....	Mammalia	→	Body covered with hairs. Females have mammary glands.
Sub-class.....	Prototheria	→	Egg-laying mammals.
Order.....	Monotremata	→	Cloaca present.
Genus.....	<i>Ornithorhynchus</i> (Duck-bill)		

**Geographical distribution :** Found in South Eastern Australia and Tasmania. Triassic to Recent.

**Habit and habitat :** It is a native of rivers, pools and creeks. It burrows to 12 to 15 metres along the river banks. It feeds on fresh-water invertebrates, carried in cheek pouches.

#### Comments :

- (1) Commonly called as **duck-billed-platypus**.
- (2) It measures about 50 cm in length having fine short fur, dark brown colour and combines the characters of a duck with a mammal.
- (3) Body is divided into **head, thick trunk and tail**. Body and tail contain soft hairs.
- (4) Head distinct. Upper jaw produced to form a flattened beak which is covered with a smooth, hairless skin that forms a free fold at the base of the beak. Head contains nostril mouth and external ear opening.
- (5) Adult has **no teeth**. Jaws covered with horny plates. **Pinnae absent**.
- (6) **Forelimbs** and **hind limbs** have **5 digits, web** and **clawed toes**. Hind limb has **horny spur**. Tail is flattened and adapted for swimming.
- (7) Coracoid and precoracoid present. T-shaped interclavicle.
- (8) **Eyes** small having **nictitating membrane**. **Mammary glands without nipples**.
- (9) Cloaca present. Ureters open in dorsal wall of urinogenital passage. **Testes abdominal**, penis conducts only sperms. Oviducts distinct, uterus or vagina absent.
- (10) Female makes nest of roots and leaves during spring in burrows, lays 1-3 eggs. About 0.5 cm long young one is hatched. It **nurses** by lapping up milk secreted by scattered mammary glands on the abdomen of female.

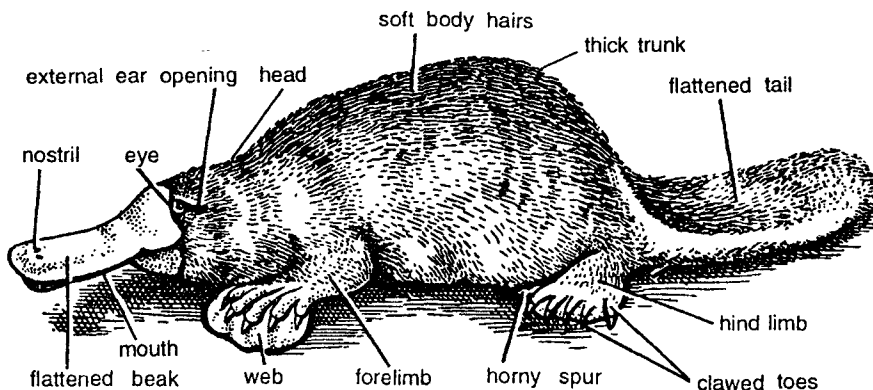

Fig. 130. *Ornithorhynchus* : Duck-bill.

**Special features :** *Ornithorhynchus* is an egg-laying mammal and exhibits **reptilian**, **mammalian** and **intermediate** characters. **Reptilian** features are urinogenital system, precoracoids, absence of pinna and corpus collosum. **Mammalian** features include hair, diaphragm, 4-chambered heart, 3-ear ossicles, etc. **Intermediate** features include mammary glands without nipples, acromion spines in the scapulae and body temperature between 25 - 28°C is imperfect thermoregulator.

**Identification :** Since this mammal has flat bill and above features, hence it is *Ornithorhynchus*.

### 131. *Echidna* = *Tachyglossus* : Spiny Anteater

**Classification :** Same as that of *Ornithorhynchus*.

Genus..... *Tachyglossus*

**Geographical distribution :** Distributed in Australia, Tasmania and New Guinea.

**Habit and habitat :** It is **terrestrial burrowing** and **nocturnal**. Feeds on ants.

**Comments :**

- (1) Commonly called as **spiny anteater**. Body divisible into **head**, **neck** and **trunk**.
- (2) Externally neck and body indistinct and covered with strong **pointed spines**. Course hair lies at the base of spines. Lower surface has only hairs, no spines.
- (3) **Head** small and produced into a small **tubular pointed snout**. Containing **eye** and **nostril**.
- (4) **Eyes** small, without nictitating membrane. **External ears absent**. Tongue long and sticky and teeth absent in adult.
- (5) **Girdles forelimbs** and **hind limbs reptile-like**. **Feet without web**. Sharp claws used for digging the earth and nests of insects.
- (6) Second digit of **hind limb** has a long and curved toilet claw to clean spines. Tarsus of male has a grooved horny poison spur.
- (7) **Male** also possesses **mammary glands** secreting milk and this condition is called as **gynaecomastisus**, where both parents nourish young one. **Teats absent**.
- (8) Mammary glands open inside a ventral abdominal pouch by several apertures. Eggs transferred by mother into the pouch where the young are nourished with milk.
- (9) In defensive position *Echidna* rolls in such a manner that bilateral barrier of spines completely covers it.

**Special features :** *Echidna* has phylogenetic significance, as it serves a **link** between reptiles and mammals. The animal is specialized for **ant eating**. The jaws are pointed forming a rostrum devoid of any teeth. Tongue is protrusible. The posterior region of the tongue is serrated to grind insects and the secretion of salivary gland neutralizes formic acid of ants.

**Identification :** Since this mammal has tubular snout, spiny body and above features, hence it is *Echidna*.

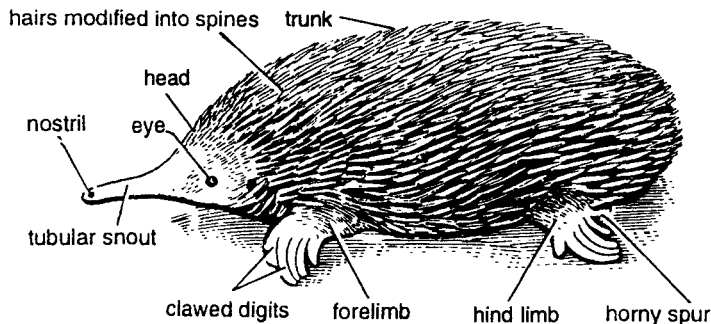

Fig. 131. *Tachyglossus* : Spiny anteater.

### 132. *Macropus* : Kangaroo

**Classification :** Same as in *Ornithorhynchus* (upto Sub-class).

Infra-class.....	Metatheria	→	Pouched and viviparous.
Order.....	Masupialia	→	Females with marsupium.
Genus.....	<i>Macropus</i>		

**Geographical distribution :** Kangaroos are found in Australia, Tasmania and New Zealand.

**Habit and habitat :** Terrestrial, gregarious, herbivorous, browsing and leaping animals.

**Comments :**

- (1) Commonly called as **Kangaroo**.
- (2) *Macropus* is **largest** Kangaroo. Males standing a maximum height of 2 meters. and weighing about 80-100 kg. Females 1.5 meters tall and 35-40 kg in weight.
- (3) Body divisible into head, neck, back, abdomen and tail. Head is small with large **ears** and **eyes**.
- (4) **Hind legs** and feet very long and powerful, used for leaping. **Forelimbs** smaller.
- (5) **Hallux** absent, 2nd and 3rd toes united (**Syndactylus**). Middle or 4th toe enormously enlarged and armed with a powerful **claw**. Called as **toilet claw**.
- (6) Animal nearly sits on its tail during rest. The **baby kangaroo** is seen **protruding** from the **marsupium** on abdomen. Young one feeds on milk through teats in marsupium.
- (7) Tail **non-prehensile** and powerful.
- (8) Other kangaroos are red kangaroo and gray kangaroo.

**Special features :** Kangaroos have abdominal pouch to carry young one, which is a characteristic feature of marsupials. Marsupials are mammals basically similar to Eutheria but whose youngers are born in rudimentary conditions and are generally sheltered during their later development in **pouch** or **marsupium**.

**Identification :** Since the animal contain marsupium and above features, hence it is **Kangaroo**.

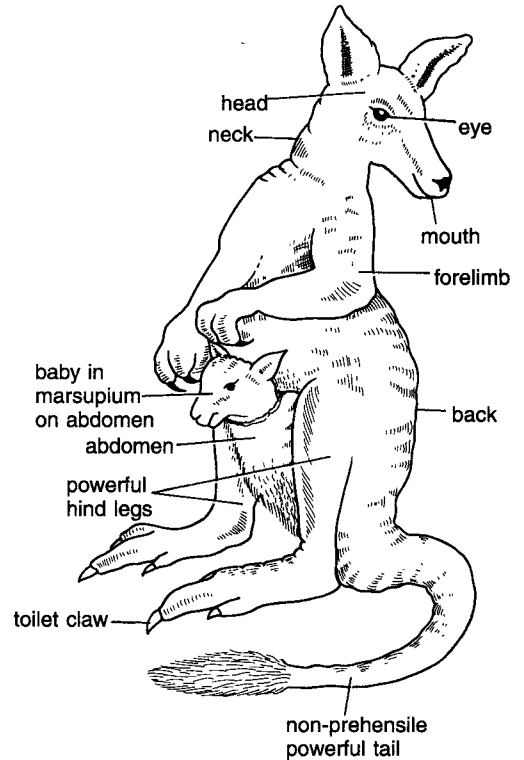

Fig. 132. *Macropus* : Kangaroo.

### 133. *Erinaceus* : Hedgehog

**Classification :**

Phylum.....	Chordata	→	Dorsal tubular nerve cord, notochord and gill-slits present.
Group.....	Craniata	→	Definite head. Cranium with brain present.
Subphylum.....	Vertebrata	→	Vertebral column present.
Division.....	Gnathostomata	→	Jaws and paired appendages present.
Superclass.....	Tetrapoda	→	Paired limbs, lungs, cornified skin and bony skeleton.
Class.....	Mammalia	→	Body covered with hairs. Females have mammary glands.
Sub-class.....	Theria	→	Viviparous mammals.
Infraclass.....	Eutheria	→	Placental mammals. Vagina single.
Order.....	Insectivora	→	Feed on insects.
Genus.....	<i>Erinaceus</i> (Hedgehog)		

**Geographical distribution :** *Erinaceus* is found in northern hemisphere, West Indies, Africa and India. Cretaceous to Recent.



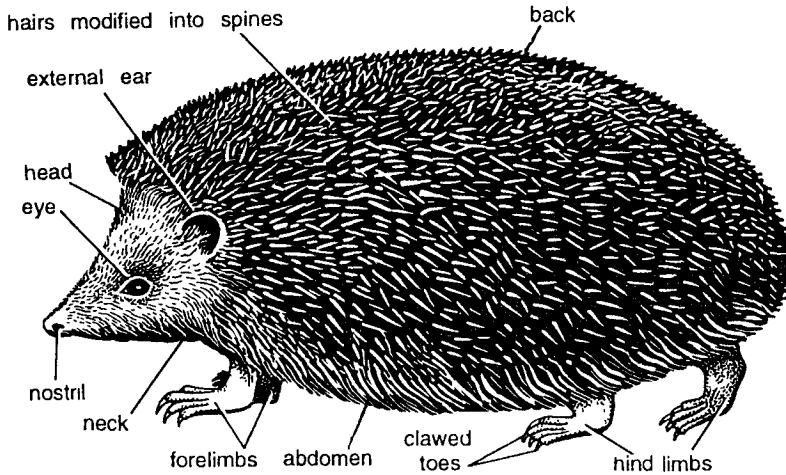

Fig. 133. *Erinaceus* : Hedgehog.

**Habit and habitat :** It inhabits holes and bushes during day and it comes out during night to feed. It is **omnivorous**, feeding on fruits, roots, insects, worms, slugs and other small animals. Hedgehog hibernates during winter. When alarmed or disturbed, it has the habit of rolling its body like a spiny rounded ball.

**Comments :**

- (1) Commonly called as **hedgehog**.
- (2) Animal characterized by the presence of sharp **backwardly directed** spines on dorsal side, while ventral side has soft fur. Body elevated above ground and divided into **head, neck, back and abdomen**.
- (3) **Head** conical and produced into a small **snout** bearing nostrils at the tip.
- (4) **Mouth** small bearing 36 sharp pointed teeth.
- (5) **Eyes** small. **Pinnæ** and **legs** short. No **marsupial bone** or **pouch**. Number of ribs 14-15.
- (6) Hind and forelimbs short.
- (7) A muscle band is found over neck and sides to move spines.
- (8) **Vagina single**, **foetus** develops within uterus of female, attached by a placenta.

**Special features :** These are probably the most **primitive** of the **Eutherians**. The brain represents low grade of organization. **Cranial cavity is small**. The stomach is simple. The allantoic placenta is discoidal and deciduate but there is a provisional yolk sac placenta. Many young are born at a time. When disturbed hairs of dorsal surface become converted into spines and due to strong development of dermal muscles. The animal rolls into a spiny rounded ball.

**Identification :** Since this mammal has sharp backwardly directed spines and above features, hence it is *Erinaceus*.

### 134. *Talpa* : Mole

**Classification :** Same as that of *Erinaceus*.

Genus..... *Talpa*

**Geographical distribution :** *Talpa* is found in India (Assam) and the western Himalayas. Cretaceous to Recent.

**Habit and habitat :** It is **adapted** for **subterranean burrowing** and lives in tunnels. It feeds on small worms, insects and sprouted seeds. It runs deeper into tunnels.

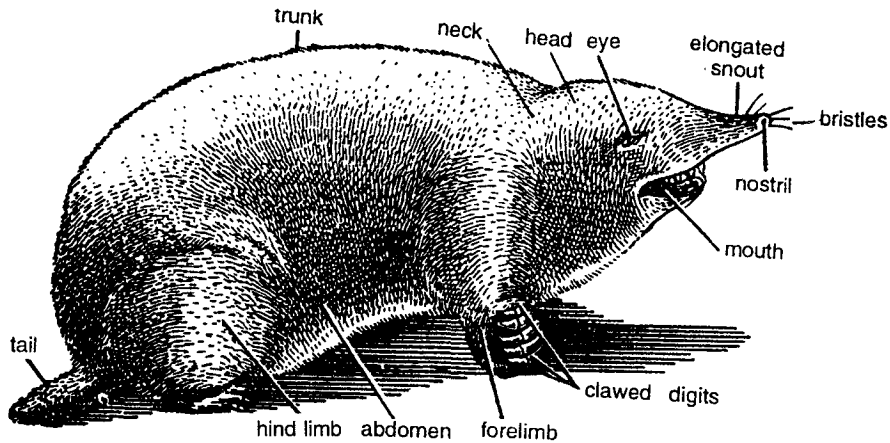
Fig. 134. *Talpa*.**Comments :**

- (1) Commonly called as **mole**.
- (2) **Pigmentation** is uniformly velvet-black, with a silver-grey glossy texture.
- (3) Body measuring 15 cm in length, divided into **head**, **short neck**, **trunk** or back and abdomen.
- (4) **Head** wedge-shaped. **Snout** elongated having prenasal bone. Snout contains **bristles** or vibrissae at the tip.
- (5) **Eyes** are very much reduced and covered with skin. **External ears (pinnae) absent**.
- (6) Tail is short, sensory and without hair. **Tail** and feet are fleshy white.
- (7) Hind limb large and broad containing 5 digits, each having broad nail, used for digging.
- (8) Forelimb usually with 5 clawed-toes; inner toes not opposable.
- (9) **No marsupial pouch. Single vagina.** Foetus develops within the body of female attached by a placenta to wall of uterus.

**Special features :** It represents a **primitive Eutherian** having **small cranial cavity**, low grade brain (smooth cerebral hemispheres), **inguinal testes**, discoidal and deciduate **placenta** with provision for yolk sac placenta.

**Identification :** Since this mammal has elongated snout, wedge-shaped head and above features, hence it is *Talpa*.

### 135. *Sorex* : Shrew

**Classification :** Same as that of *Erinaceus*.

Genus.....*Sorex*

**Geographical distribution :** *Sorex* is found throughout the world. Miocene to Recent.

**Habit and habitat :** It lives in burrows feeding voraciously on insects, small invertebrates and some rodents.

**Comments :**

- (1) Commonly called as **shrew**.
- (2) Entire body is covered with short and soft steel-grey **fur (pelage)**.
- (3) Body divided into **head**, **trunk**, **abdomen** and **tail**. Head contains **snout**, **eyes** and **vibrissae** or moustaches.
- (4) **Snout** is elongated and contains several moustaches.
- (5) **Eyes** are small, rudimentary and not covered. Pinnae absent.

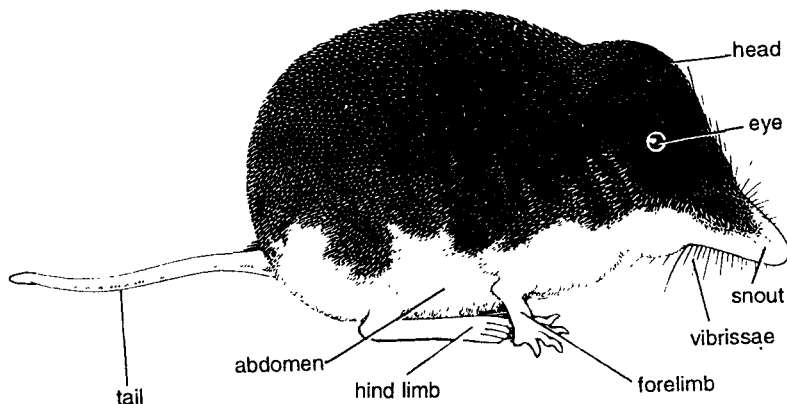
Fig. 135. *Sorex*.

- (6) Elongated tail is covered with scales.
- (7) **Mammary gland with definite teats present.**
- (8) Forelimbs and hind limbs well developed.

**Special features :** *Sorex* is a very ancient genus, found from Miocene onwards. It has undergone little change. It shows all primitive Eutherian characters as mentioned for Hedgehog and Mole.

**Identification :** Since this mammal has steel grey fur and above features, hence it is *Sorex*.

### 136. *Loris*

**Classification :** Same as in *Erinaceus* (upto Infra-class).

Order.....	Primates	→	Head turns easily on neck.
Sub-order.....	Lemuroidea	→	Head without snout.
Genus.....	<i>Loris</i>		

**Geographical distribution :** These are found outside Madagascar and specially in India and Sri Lanka. Pliocene to Recent.

**Habit and habitat :** *Loris* is solitary, nocturnal and arboreal primate.

**Comments :**

- (1) Body is covered with brownish fur with silver look. Fur is thick and woolly.
- (2) Body divided into head, trunk, abdomen and tail. Head contains snout, nostril, large eyes and ear.
- (3) **Head** small and produced into snout.
- (4) **Eyes** are closely placed. They are very distinct and bulging. Orbit is forwardly directed.
- (5) External ear or **pinna** is conical.
- (6) Nostrils in the form of small apertures.
- (7) **Teeth** thecodont and heterodont.
- (8) Tail long but not **prehensile**.
- (9) Limbs elongated. Some toes clawed, others with flat nails. Locomotion remarkably slow. It is often found **hanging upside down**.
- (10) They seem to be survival of an earlier stock.

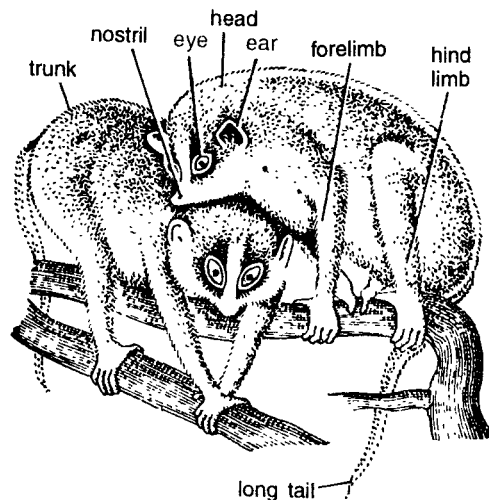
Fig. 136. *Loris*.

**Special features :** In *Lorises* traces of very early features remain, including a transverse fold of skin on abdomen of the female, which is considered by some to represent a **marsupium**. They show some features that recall the higher primates. For example, the tympanic ring is fused to the petrosal bulla. The face in some is shorter and brain rounder than in true lemurs.

**Identification :** Since this mammal has forward directed orbits and above features, hence it is *Loris*.

### 137. *Pteropus* = *Cynopterus* : Flying Fox

**Classification :** Same as in *Erinaceus* (upto Infra-class).

Order..... *Chiroptera* → Flying mammals.  
 Sub-order..... *Megachiroptera* → Hanging downwards with folding wings.  
 Genus..... *Cynopterus*

**Geographical distribution :** Found in South Eastern Asia, especially in India. Pliocene to Recent.

**Habit and habitat :** Adapted for **arboreal** and aerial mode of life. Live in groups and feed on fruits (**frugivorous**) and often damage orchards. They sleep by day on tree branches.

**Comments :**

- (1) Commonly called **Fruit bat** or **Flying fox** and in Hindi **Chamgadar**.
- (2) Body is dark-brown coloured and shoulders are golden yellow. Body divisible into **head, neck, trunk and tail and patagium**.
- (3) It is capable of **true flight**. The forelimbs are modified into wings.
- (4) Each **wing** formed by a fold of **skin or patagium** supported by elongated forelimb and 2nd to 5th fingers. Only 1st and 2nd fingers bear claws.
- (5) **Hind limbs** and tail also included in **patagium**. Before patagium is **prepatagium**. Hind feet small with sharp and curved claws. **Tail** small and **stumpy**.
- (6) **Head** small having small external **ears**, large **eyes**, **snout** and **small teeth**.
- (7) During sleep, **head hangs downwards** with wings folded clock-like around body.

**Special features :** Bats are important due to five reasons : (i) They have **phylogenetic** significance with **insectivores**, (ii) They are the only **flying mammals**, (iii) They are used for **experimental** purposes, (iv) Faeces of bats are used as **fertilizer**, (v) Bats have highly developed **Sonar** or **Echoapparatus**, a kind of **radar**. While flying they constantly send out ultrasonic sound waves consisting of periodic clicks, which strike on objects or wire and are reflected back to bat. Rate of click increases 50-150 seconds as the object is approached. **Ultrasonic sounds** are produced from the **vocal cords**.

**Identification :** Since the animal has patagium and above features, hence it is *Pteropus*.

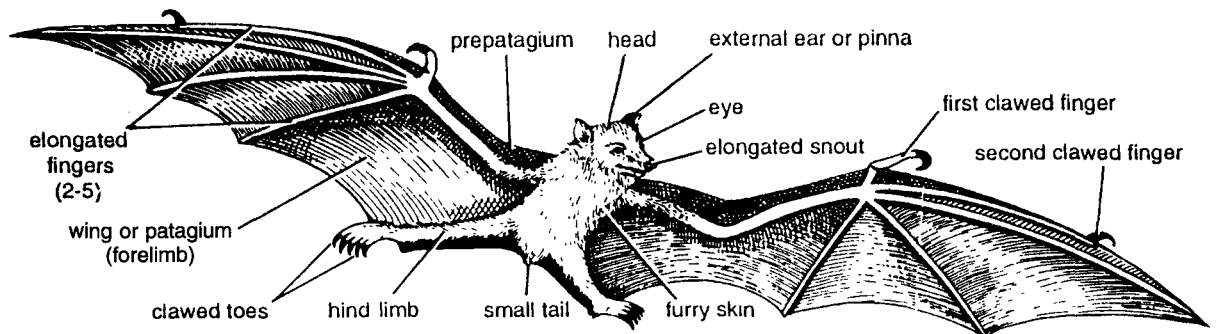
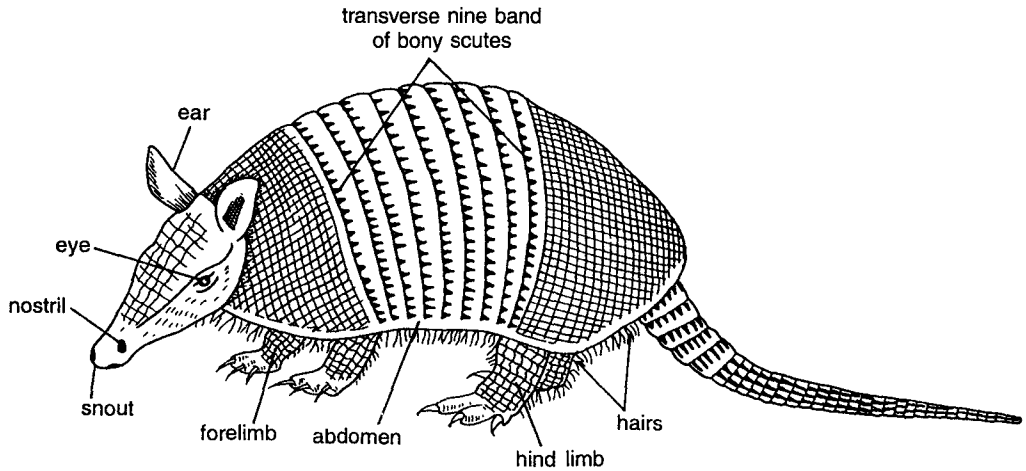

Fig. 137. *Cynopterus* : Indian fruit bat.

Fig. 138. *Dasypus*.

### 138. *Dasypus* : Armadillo

**Classification :** Same as in *Erinaceus* (upto Infra-class).

Order..... *Edentata* → Teeth reduced to molars. Toes clawed.

Genus..... *Dasypus*

**Geographical distribution :** Found in South and Central America.

**Habit and habitat.** Burrowing.

**Comments :**

- (1) Commonly called as **nine-banded armadillo**.
- (2) Body 75 cm long and divisible into head, trunk, tail and abdomen.
- (3) Body covered with well developed **dermal skeleton of bony scutes** arranged in transverse bands.
- (4) Bony scutes are covered with bony plates or scales having hairs and flexible skin. Head **contains, eyes, nostrils** and bony scutes. Conical ears prominent. Head is produced into snout.
- (5) In genus *Dasypus*, there has been extra-ordinary secondary specialization in the production of identical quadruplets in *Dasypus novemcincta* and 8-12 in *D. hybrida*.
- (6) **Forelimbs** and **hind limbs** hairy.
- (7) The prolonged period of **gestation** of 18 weeks in *D. novemcincta* probably reduces the dependence of the neonatal young on lactation.

**Identification :** Since the animal has transverse bands and above features, hence it is called as *Dasypus*.

### 139. *Manis* : Scaly Anteater

**Classification :** Same as in *Erinaceus* (upto Infra-class).

Order..... *Pholidota* → Body covered by large overlapping plates.

Genus..... *Manis*

**Geographical distribution :** *Manis* is found in Africa and South Eastern Asia, India (Assam), Sikkim, Nepal and the Himalayas.

**Habit and habitat :** It is found in the hilly tracts. It is a nocturnal and burrowing mammal. It feeds on ants and termites whose nest is broken by its sharp fore-claws.

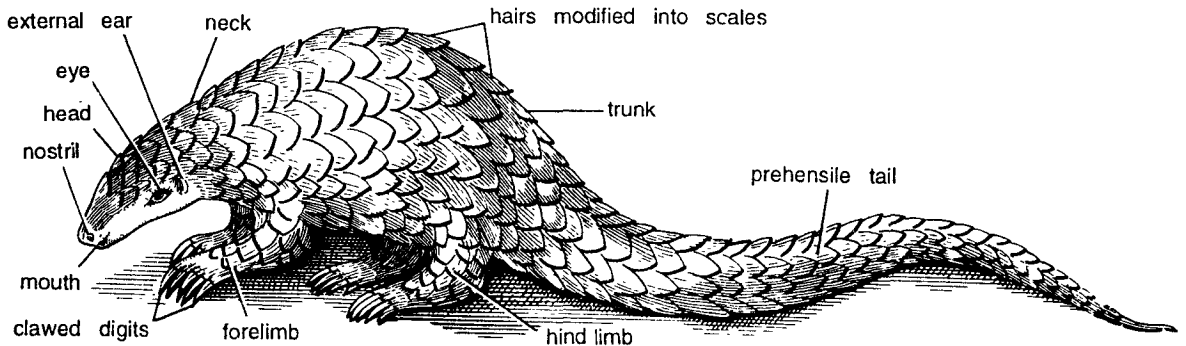

Fig. 139. *Manis* : Scaly anteater.

**Comments :**

- (1) Commonly called as **scaly anteater** or **pangolin**.
- (2) Body measures about 90 cm in length and is divided into **head, neck, trunk, tail** and **abdomen**.
- (3) Body covered by imbricating **thick horny, overlapping scales** arranged in **longitudinal rows**. Scales are thick and striated at the base, yellowish brown or clay coloured.
- (4) Between scales **coarse hairs** are found. Ventral body surface is covered with hairs.
- (5) **Head** small. Snout pointed. Teeth absent. **Eyes** and **pinnae** small. Tongue long and **glutinous**.
- (6) **Tail** is long and broad **prehensile** contains 16-17 scales in each row.
- (7) Pangolins walk slowly with arched back and the forelimbs and anterior surface in contact with the ground. Limbs are strong and **pentadactyle**. Forelimb provided with strong curved **claws** while hind limbs are **plantigrade**.
- (8) Pyloric stomach works like gizzard of birds, having small pebbles or stones in it and hence it is called as **stone-eater** or **bajrokit**.

**Special features :** When disturbed, it rolls its body with head between the forelegs and tail around body.

**Identification :** Since this mammal has distinct scales and above features, hence it is *Manis*.

### 140. *Macaca mulata* : Rhesus Monkey

**Classification :** Same as in *Erinaceus*.

Order.....	Primates	→	Head turns easily on neck.
Sub-order.....	Anthropoidea	→	Eyes directed forwards.
Genus.....	<i>Macaca</i>		
Species.....	<i>mulata</i>		

**Geographical distribution :** Old world monkeys found in India, China, Vietnam and Asia.

**Habit and habitat :** **Arboreal** (tree living), terrestrial, diurnal and social.

**Comments :**

- (1) Commonly called as **Rhesus monkey** or **Bandar**. Body divided into **head, trunk, tail** and **abdomen**. Head contains, mouth, eye and nostril.
- (2) **Cranium enlarged**, nostrils ringed by bare skin.
- (3) Protrusible **fascial muscles** permit emotional expression.
- (4) Body covered with brownish or golden hairs,
- (5) **Nostrils** parallel and directed downwards.

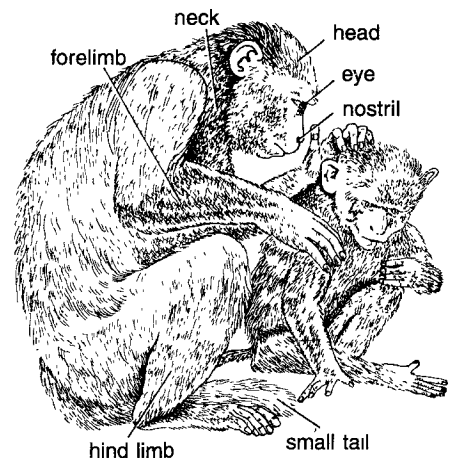

Fig. 140. *Macaca* : Rhesus monkey.

- (6) Internal **cheek** pouched for storing the food.
- (7) **Buttocks** contain two dried **tuberosities** with exposed **calloused skin**.
- (8) Stomach single.
- (9) **External ear** reduced. Forelimbs and hind limbs well developed.

**Special features** : Monkeys are famous for caricaturing. Trained monkey's dance provides amusement to children. **Rh blood** factor was first discovered in monkeys which has great significance in blood transfusions. Monkeys exhibit **parental care**. Other monkeys are Squirrel monkey (*Saimiri*), Spider monkey (*Ateles*), Marmoset (*Callithrix*) and Langur (*Presbystis*).

**Identification** : Since the animal contains ischial tuberosities and all above features, hence it is *Macaca*.

### 141. *Hylobates* : Gibbon

**Classification** : Same as that of **Rhesus monkey**.

Genus..... *Hylobates*

**Geographical distribution** : South East Asia and Malaya Archipelago.

**Habit and habitat** : Chiefly arboreal, found in rain forests upto 71,000 feet. Strongly territorial. Rarely descend to ground.

**Comments** :

- (1) Commonly called as **gibbon**.
- (2) Body slender, **thickly furred** and **tailless**.
- (3) **Height** 3 feet. Body divided into head, neck, trunk.
- (4) Head contains **sunken orbit** (eyes) **flat nose** and black face with mouth.
- (5) Prominent **callous pads** on buttocks.
- (6) Gibbons are known for their **remarkable calls**.
- (7) Male and female differ in colours. Female basically fawn. Female brownish.
- (8) **Forelimbs** and **hind limbs** well developed. Forelimbs are long and Gibbons swing around trees with great speed.
- (9) Female produces young one after every 2 years. **Gestation period** 7 months.
- (10) On ground they walk on their hindlegs slowly but they seldom descend from trees.

**Special features** : Prominent animal of Zoological gardens. Extremely noisy. They howl, bark and cry.

**Identification** : Since the animal has sunken orbit and all above features, hence it is **Gibbon**.

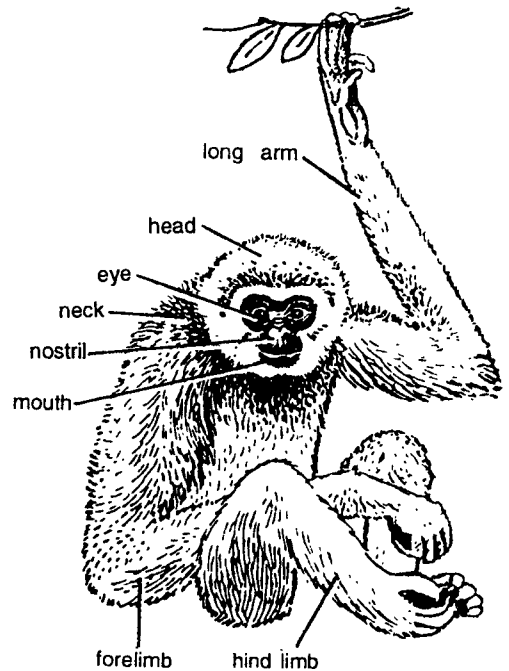

Fig. 141. *Hylobatus* : Gibbon.

### 142. *Pan triglodytes* : Chimpanzee

**Classification** : Same as that of **Rhesus monkey**.

Genus..... *Pan*

Species.....*triglodytes*

**Geographical distribution** : West African forests, Sierra Leone, Uganda and Tanganyika.

**Habit and habitat** : Arboreal but mostly lives on ground. They build nests each evening and sleep in them overnight.

**Comments :**

- (1) Commonly called as **Chimpanzee**. Body divisible into **head, neck, trunk and abdomen**.
- (2) **Size** 54 inches tall, weight 75-85 kg.
- (3) Back and thigh of adults gray. Head, neck, limbs, except face, fingers and toes are covered by thick black hairs. Back is covered by grey hairs.
- (4) **Arms** long and **legs** short.
- (5) **Muzzle** protrudes. **Skull** prominent and rounded.
- (6) **Head** rounded, **ears** large and prominent. Head contains **sunkers**, **eyes** small **nose** and **bulging lips**.
- (7) Male has a big goitre-like throat sac and two fatty-swellings in the cheeks.
- (8) Feeds on buds of fruits. Single young born and suckled for 4 years. Gestation period 225 days.
- (9) On ground it walks on **knuckles**. Forelimbs and hind limbs well developed.

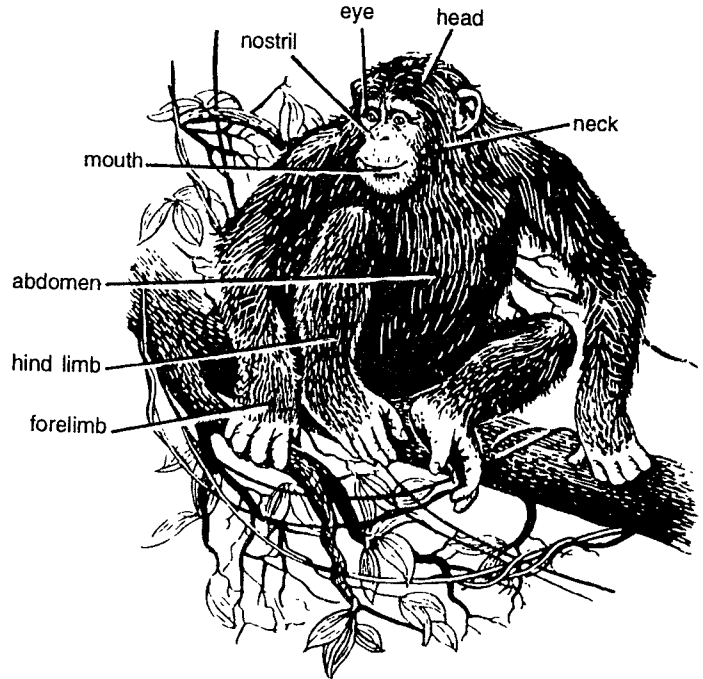
Fig. 142. *Pan trglodytes* (Chimpanzee).

**Special features :** Chimpanzees are extremely intelligent. They make and use tools regularly.

**Identification :** Since, the animal has bulding lips and above features, hence it is **Chimpanzee**.

### 143. *Pongo* : Orang-utan

**Classification :** Same as that of **Rhesus monkey**.

Genus..... *Pongo*

**Geographical distribution :** Jungles of Borneo and Sumatra and outside Central Africa, East Indies and West of Wallace line.

**Habit and habitat :** Arboreal, fruigivorous.

**Comments :**

- (1) Commonly called as **Orang-utan** (Fig. 143).
- (2) Body divisible into **head, neck, trunk, tail and abdomen**.
- (3) **Fore head** high, **ears** small and hairs leg eyes are sunken.
- (4) **Nostrils** large and lips bulding with **mouth** fore head.
- (5) Face and palm naked. Cheek pouches particularly in older males. Males develop pouch-like throat swellings like **goiters**.
- (6) Males stand 4.5 feet. Females much smaller. Weight nearly 400 pounds.
- (7) Entire body except fingers face and toes covered by hairs.
- (8) **Arms** exceptionally long.
- (9) **Legs** relatively short.
- (10) Fur reddish brown and getting darker in older males.
- (11) **Ribs** 12 pairs and thoracic **vertebrae** 12, as in man.



**Special features :** Older males make loud roars when disturbed. They swing from branch to branch. Gait clumsy and arms held over its head. Live singly or in pairs or in groups of four. Females give birth to a single individual after every 4 years. **Gestation** period 275 days. Young are suckled for 18 months. They mature in 10 years. Life span 25 years. Captive orang-utans become friendly.

**Identification :** Since the animal contains high forehead and all above features, hence it is **Orang utans**.

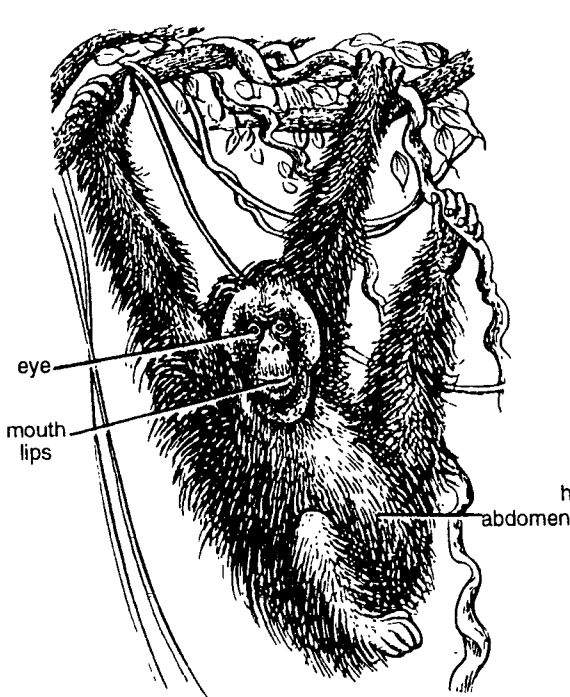

Fig. 143. *Pongo* : Orang-utan.

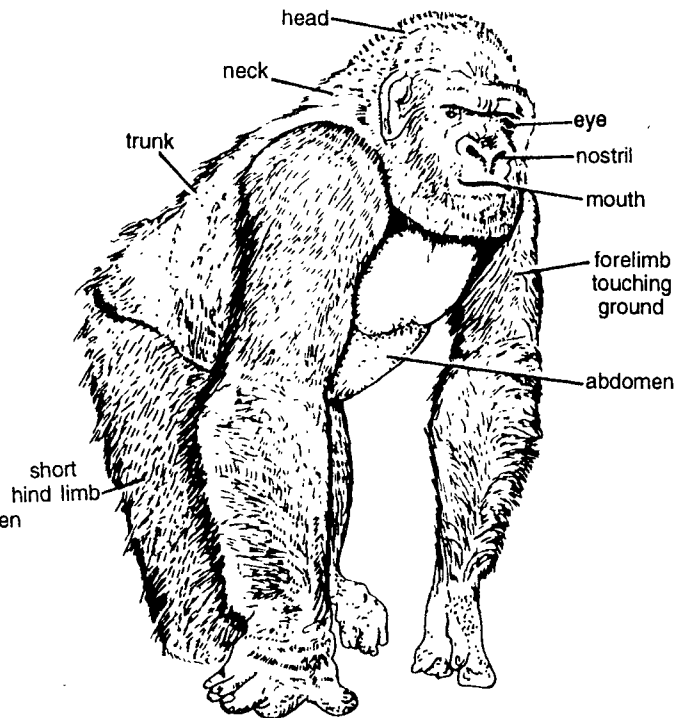

Fig. 144. *Gorilla* : Gorilla.

## 144. *Gorilla* : Gorilla

**Classification :** Same as that of Rhesus monkey.

Genus..... *Gorilla*

**Geographical distribution :** Equatorial African forests of Cameron and Congo.

**Habit and habitat :** Lives chiefly on ground leading social life. Forming family group of 30. **Nomadic** primate. **Ferocious, untamable.**

**Comments :**

- (1) Commonly called as **Gorilla**.
- (2) *Gorilla* represents largest and heaviest of the primates measuring about 6 feet and measuring about 300 kg.
- (3) Body divisible into heavily built **head, neck, trunk and abdomen**.
- (4) Mountain gorilla are covered with black fur and low land gorilla with brown fur.
- (5) Size 1.8 meters tall. Weight about 250 kg Except fingers and toes entire body is covered by hairs.
- (6) Body inclined. Walks semierect on **plantigrade** soles of feet aided by **knuckles** of hands.
- (7) Head contains eyes, nostrils and bulging **mouth lips**.

(Z-21)

(8) Feeds on plants foliage and fruits.

(9) Not noisy.

**Special features :** Hands elongated touching grounds. Hind limbs short. Gorilla lives in territorial family group of 10-20 animals dominated by an old polygamous male.

**Identification :** Since the animal has heavy inclined body and all above features, hence it is *Gorilla*

### 145. *Homo sapiens* : Man

**Classification :** Same as that of Rhesus monkey.

Genus.....*Homo*

Species.....*sapiens*

**Geographical distribution :** All over the world. Now invading Antarctica and trying to establish in space.

**Habit and habitat :** Completely social. Terrestrial, lives in plains and on mountains. Gentle and clever.

**Comments :**

- (1) Commonly called man. Sexual dimorphism prominent. Male and female completely distinct.
- (2) Most intelligent. **Cranial capacity** best developed.
- (3) Size varies from generally 5 feet to 6 feet. Few dwarf persons also occur.
- (4) Body divisible into distinct **head, neck, chest, abdomen** and back.
- (5) **Posture erect** with **binocular vision**.
- (6) Man can be distinguished from all other mammals by having **power of speech and talking**.
- (7) Depends upon **plant-animal-food chains**.
- (8) Gestation period 9 months. Generally producing one young one. Twins and 4 to 8 young ones are produced in rare cases.
- (9) Highest evolved and **highly social animal**.
- (10) Man dominates over all the animals.

**Identification :** Since man has power of speech and all above features, hence it is man.

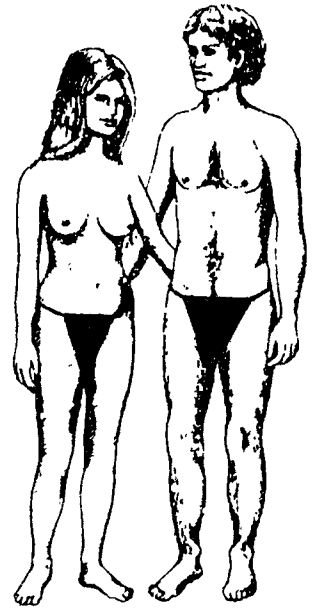

Fig. 145. *Homo sapiens* : Man.

### 146. *Oryctolagus* : Rabbit

**Classification :** Same as that of *Erinaceus* (upto Infra-class).

Order.....*Lagomorpha* → Upper incisors 2 pairs.

Genus.....*Oryctolagus*

Species.....*cuniculus*

**Geographical distribution :** Cosmopolitan.

**Habit and habitat :** Inhabiting fields, grasslands and woodlands. **Gregarious, crepuscular** (coming out of burrows for feeding in twilight), **coprophagous** (eating again their soft stool for maximum nourishment and **polygamous**).

**Comments :**

- (1) Commonly called as **Rabbit**.
- (2) Body cat-like and divisible into **head, neck, trunk abdomen** and **tail**.
- (3) Head contains long tactile **vibrissae** or **whiskers**, **external nares**, usually shorter eyes and **mouth**. External **ears** large having **external auditory meatus**.
- (4) Length 40 cm from mouth to anus.

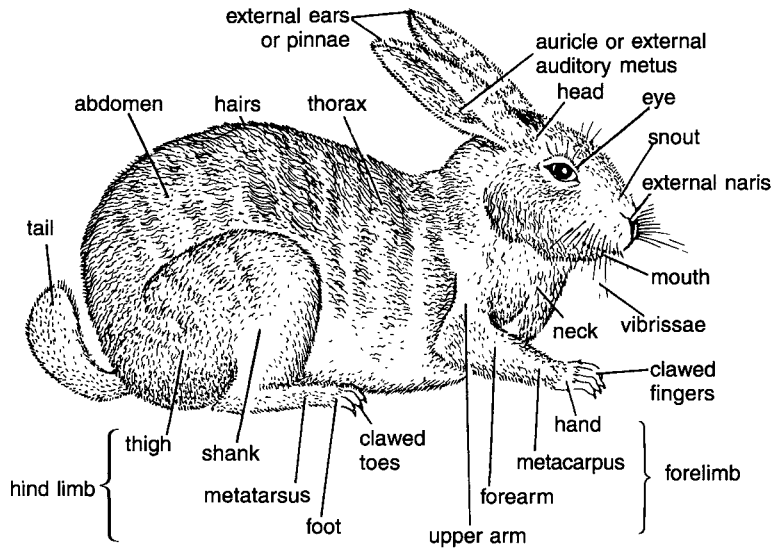

Fig. 146. *Oryctolagus*.

- (5) **Fur** colour **white**, black, brown or spotted.
- (6) Males have muscular skin-covered **penis**.
- (7) Females have **clitoris**.
- (8) **Forelimbs** used for digging and **hind limbs** for leaping. Fast runner (30 to 40 km per hour). Forelimbs contain **upper arm, forearm, metacarpus, hand** and **clawed fingers**. Hind limb contains **thigh, shank, metatarsus, foot** and **clawed toes**.

**Economic value** : Fur of rabbit is used to make purses, gloves and caps. Some varieties used as food. They also form important experiment animal for study and research. Most of chordate anatomy is based on rabbit. Rabbits are used in immunological studies for raising antibodies for immunodiagnosis.

**Identification** : Since the animal has hairy white fur and above features, hence it is **rabbit**.

### 147. *Lepus* : Hare

**Classification** : Same as that of *Oryctolagus*.

Genus..... *Lepus*

**Geographical distribution** : Cosmopolitan. North Indian hare is *Lepus ruficaudatus* and South Indian hare is *L. nigricollis*.

**Habit and habitat** : Inhabiting fields, grasslands and woodlands. Gregarious, crepuscular (coming out of burrows for feeding in twilight, **coprophagous** (eating again their soft stool for maximum nourishment). Polygamous, **nocturnal, solitary**, nomadic and living in temporary shelters.

**Comments** :

- (1) Commonly called as **Hare**.
- (2) Larger than rabbits. 50 to 70 cm long from mouth to anus. Body colour **brown** dorsally while ventral side is white.
- (3) **Body** divisible into **head, neck, trunk or back, chest** and **abdomen**.
- (4) Head contains **eyes, tactile whiskers, nares**, and **longer erect external ears**, snout, external nares and mouth. Ears contain **external auditory meatus**.
- (5) **Forelimbs** and **hind limbs** more or less equal. Tail short and bushy.

- (6) Runs at a speed of 60 km per hour.  
 (7) Wild hare can not be domesticated.

**Identification :** Since the animal has long erect pinnae and above features, hence it is **Hare**.

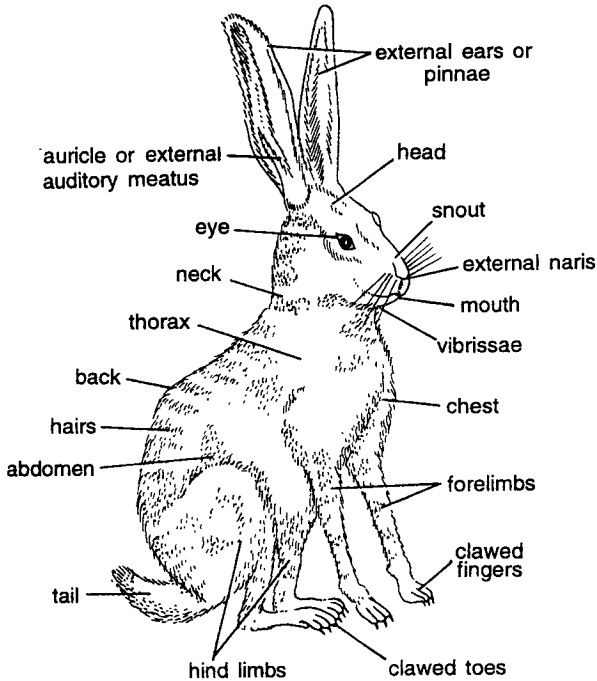

Fig. 147. *Lepus* : Hare.

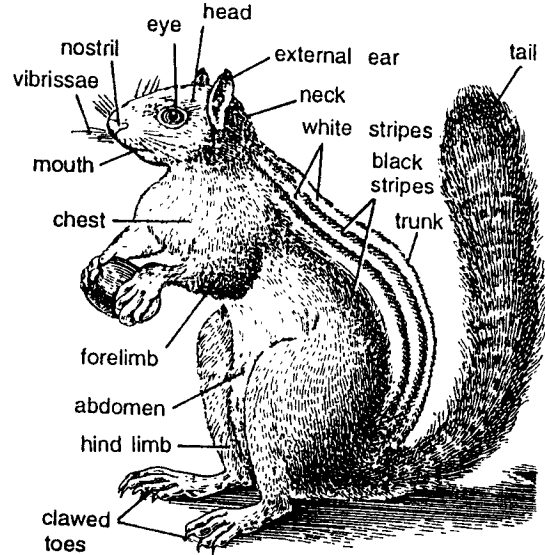

Fig. 148. *Funambulus* : Squirrel.

### 148. *Funambulus* : Squirrel

**Classification :** Same as that of *Erinaceus*.

Order..... Rodentia → Having one pair of upper incisors

Genus..... *Funambulus*

**Geographical distribution :** *Funambulus* has world-wide distribution. It is found on all continents and islands. Eocene to Recent.

**Habit and habitat :** It lives on trees, ground and is fast runner. It feeds on fruits and seeds. It builds nest of twigs and leaves. It is diurnal.

**Comments :**

- (1) Commonly called as squirrel and in Hindi **Gilahari**.
- (2) Body contains **three white** and **grey stripes** on dorsal side, absent on neck. Body divisible into **head, neck, trunk or back, chest, abdomen** and **tail**.
- (3) Ventral side and limbs covered by small grey hairs.
- (4) Head contains **snout** with **moustaches** nostrils, large eyes and well developed **pinnae**.
- (5) **Forelimbs** and **hind limbs** well developed with clawed toes. **Tail** elongated and bushy.
- (6) **Incisors** exposed **chisel-like**, rootless, grow continuously, gap between incisors and cheek teeth, canine absent and upper and lower cheek teeth about equal size. Palate narrow. **Elbow joint rotates**.
- (7) Squirrel is also used for **experimental** purposes. It is largely used in **cancerous** studies.
- (8) Squirrel destroys fruit crops.

**Identification :** Since this mammal has bushy tail, stripes and above features, hence it is **Squirrel** (*Funambulus*).

### 149. *Rattus rattus* : Black rat

**Classification :** Same as that of *Funambulus*.

Genus..... *Rattus*

Species..... *rattus*

**Geographical distribution :** *Rattus rattus* is found in all parts of the world. It prefers warmer and drier conditions. Eocene to Recent.

**Habit and habitat :** It is a common rat inhabiting holes and burrows in houses and in cultivated fields. It feeds on stored grains.

**Comments :**

- (1) Commonly called as **black rat**.
- (2) Body divisible into **head, neck, trunk and tail**.
- (3) Head contains ears, eyes, nostrils, and snout with long moustache or vibrissae.
- (4) Body and limbs covered with hairs.
- (5) **Pinnae** well developed. Eyes sharp.
- (6) Tail is elongated and scaly.
- (7) **Incisor** teeth chisel-like, open-rooted, used for gnawing. **Canines absent**.
- (8) **Viviparous**.

**Special features :** Rat destroys the **crop** and **stored grains**. It also spreads **typhus** fever and **plague**. It acts as carrier of these diseases. Rat has great **experimental** value. It is largely used in various **biophysical** and **biochemical** studies. It also acts as intermediate host for various helminthic diseases.

**Identification :** Since the animal has long vibrissae and above features, hence it is *Rattus rattus*.

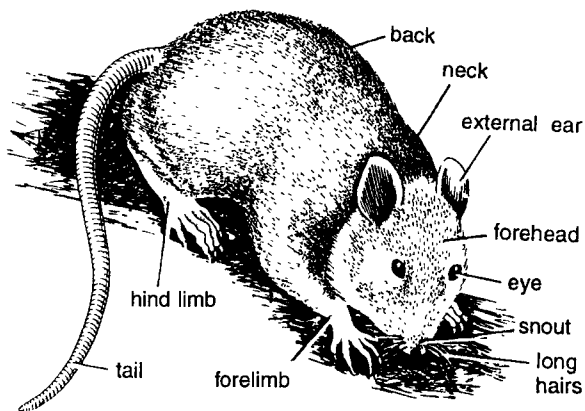

Fig. 149. *Rattus rattus*.

### 150. *Hystrix* : Porcupine

**Classification :** Same as that of *Funambulus*.

Genus..... *Hystrix*

**Geographical distribution :** *Hystrix* is found in India. Eocene to Recent.

**Habit and habitat :** It commonly inhabits river banks, nullahs and bunds. It comes out only after sunset. It is **nocturnal** and **herbivorous**.

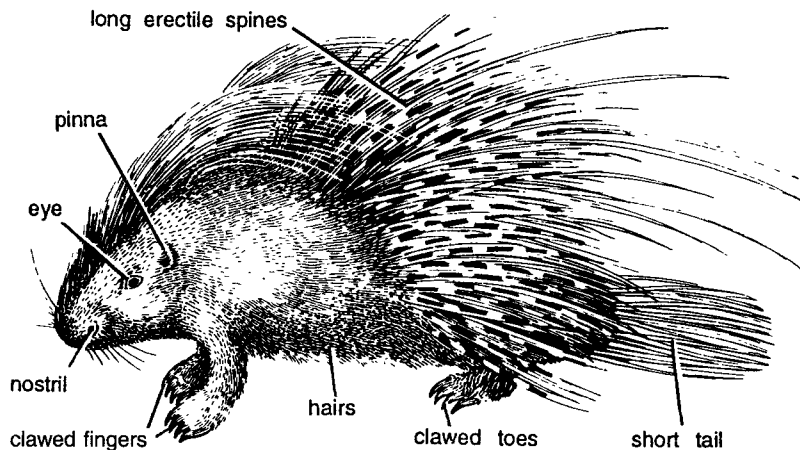

Fig. 150. *Hystrix*.

**Comments :**

- (1) Commonly called as **porcupine** and in Hindi **Sahi**.
- (2) Body of the animal measures about 1 meter. Body divisible into head, neck, trunk or back, chest, abdomen and tail. Head contains snout.
- (3) Unique and outstanding character of animal is the presence of **long spines** or **quills** which are modified hairs.
- (4) **Head** contains a crest of black bristles **eyes**, **nostrils** and **external ear**.
- (5) The spines on face and snout are short and stiff. The spines on back and lumber region are long backwardly directed and pointed.
- (6) Forelimbs and hind limbs contain clawed fingers and toes respectively.
- (7) Porcupine often attacks its enemies (dog, etc.) by erecting its spines which penetrate into the flesh of enemy.

**Special features :** Sometimes the animal rolls up in defence, and is harmful to crops of potato, carrots and cabbage.

**Identification :** Since this mammal has long still quills and above features, hence it is *Hystrix*.

### 151. *Lutra* : Otter

**Classification :** Same as in *Erinaceus* (upto Infra-class).

Order..... Carnivora → Carnivorous

Genus..... *Lutra*

**Geographical distribution :** *Lutra* is found throughout the world. Eocene to Recent.

**Habit and habitat :** It is found in the rivers throughout India. It aggregates near rocks. It is also terrestrial.

They are good and **swift swimmers** and they catch fish or frogs with remarkable swiftness. They can also be tamed.

**Comments :**

- (1) Commonly called **otter** in English or **Udbilao** in Hindi. Body divided into **head**, **neck**, **trunk**, **chest**, **abdomen** and **tail**.
- (2) Typical small carnivore with several primitive characters.
- (3) Body elongated and covered with short **fur**.
- (4) Cat-like head contains small **eyes**, long **hairs** and small ears and mouth.

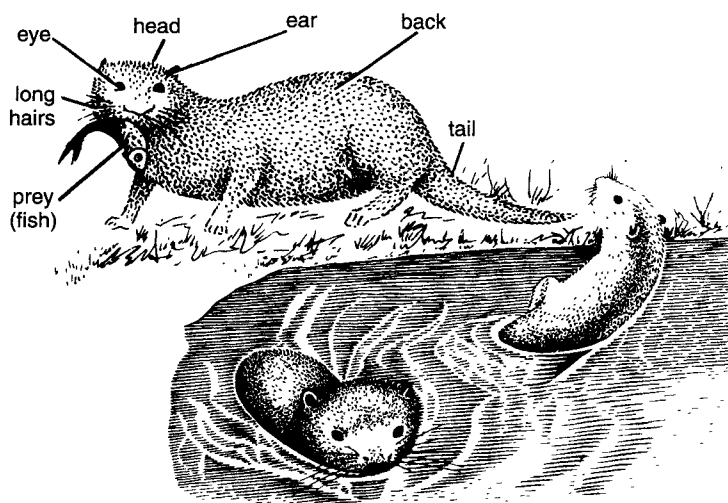

Fig. 151. *Lutra* : Otter.

- (5) Forelimbs and hind limbs are adapted for swimming having webbed toes.  
 (6) Teeth thecodont with well-developed **canines**.

**Identification** : Since this mammal has cat-like head and above features, hence it is *Lutra*.

### 152. *Herpestes* : Mongoose

**Classification** : Same as that of *Erinaceus* (upto Infra-class).

Order..... Carnivora → Carnivorous

Genus..... *Herpestes*

**Geographical distribution** : Abundantly found in Asian and African countries. Eocene to Recent.

**Habit and habitat** : It is a burrowing mammal. It is nocturnal and feeds on small mammals, reptiles, birds and eggs.

**Comments** :

- (1) Commonly called as **mongoose** in English and **Neola** in Hindi.
- (2) It is a small and highly modified **carnivore**.
- (3) Entire body is covered with **greyish fur**.
- (4) Body divided into **head, neck, trunk, chest, abdomen** and **tail**.
- (5) It has long skull, small brain and short legs.
- (6) Head contains small snout, ears, small eyes, and nose.
- (7) Tail is elongated and bushy.
- (8) Forelimbs and hind limbs have 5 digits with **fussorial** claws.
- (9) Teeth **thecodont** and **heterodont** with well-developed canines.

**Special features** : The **fight** between **mongoose** and **snake** is famous but ultimately the mongoose wins and kills the snake.

**Identification** : Since this mammal has greyish furs and above features, hence it is *Herpestes*.

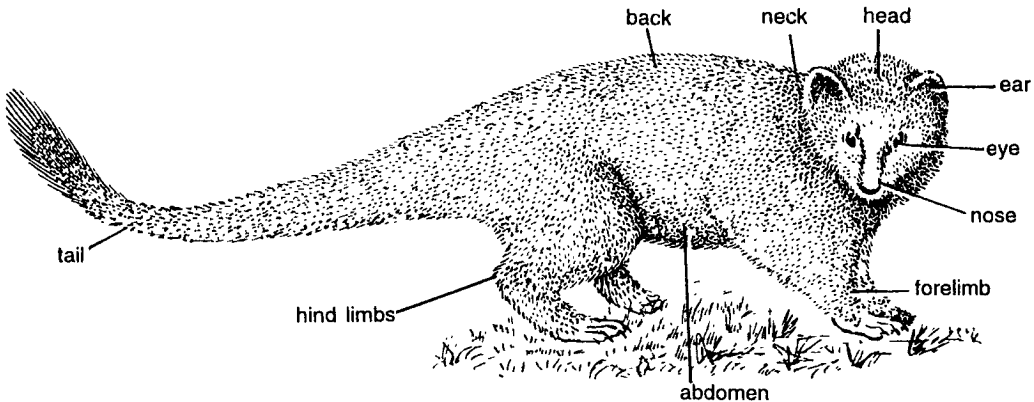

Fig. 152. *Herpestes* (mongoose).

### 153. *Felis domesticus* : Cat

**Classification** : Same as that of *Erinaceus* (upto Infra-class).

Order..... Carnivora → Carnivorous

Genus..... *Felis*

Species..... *domesticus*

**Geographical distribution** : Found in tropical and sub-tropical countries except Australia, Madagascar, West Indies and Antarctica.

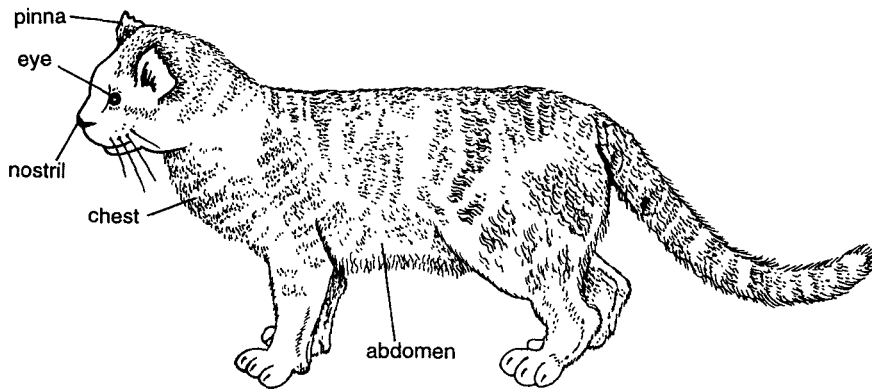

Fig. 153. *Felis domesticus* : Cat.

**Habit and habitat :** Solitary, nocturnal, preferring darkness and living with human habitate. Cats are domesticated and hence the name domesticus.

**Comments :**

- (1) Commonly called as **cat** or **Billi**.
- (2) Body divided into **head, neck, trunk, chest, abdomen** and **tail**.
- (3) Head more or less rounded with prominent **bulging eyes** pinnae and nostrils.
- (4) Cats have excellent **sight** and hearing.
- (5) Legs short. Have sharp **claws** retractable into protective sheath.
- (6) Gestation period 8 weeks. Give birth to 2 to 4 **kittens**.

**Special features :** Cats kill rats and hence act as biological control. Cat-rat stories are famous. Cats are often mentioned to make children afraid. Recently, cats have gained importance for advanced brain researches. Children are amused by the wood *meayon-meayon*. Eyes of cats are peculiar and they can see in darkness.

**Identification :** Since the animal contains bulging eyes and all above features, hence it is **cat**.

## 154. *Felis leo* : Lion

**Classification :** Same as that of *Erinaceus* upto infra-class.

Order..... Carnivora → Carnivorous

Genus..... *Felis*

Species..... *leo*

**Geographical distribution :** Found in Africa, South of Sahara, Asia and Gir forest of Gujarat in India.

**Habit and habitat :** Lives in thick forest. Massive carnivore. Terrestrial and nocturnal.

**Comments :**

- (1) Commonly called as **lion** or **Bubbar sher** (Fig. 154).
- (2) Body contains dark brown or **fawny yellow fur**.
- (3) Body divisible into **head, neck, trunk or back, chest, abdomen** and **tail**. Head is **large, massive** and **majestic** looking having **eyes, ears** and **whiskers**.
- (4) Males larger than females and measure 3.5 feet tall and 450 pounds in weight.
- (5) Only male has **mane**. Mane darker than body covering head and shoulder, sometimes extending upto belly.
- (6) Mouth contains highly powerful **jaws** specialized for sudden puncturing the body of prey. Premolars and molars small. **Canines** acts as powerful **fangs**.



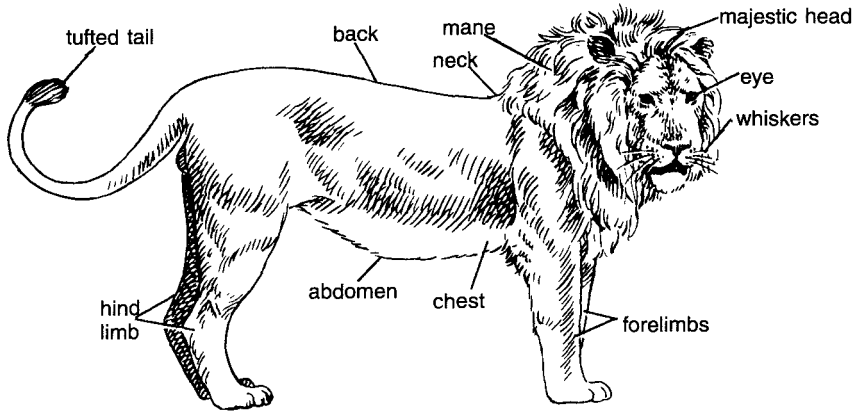

Fig. 154. *Felis leo* : Lion.

- (7) **Tail** long with a black tuft which conceals a sharp horny tail spur.
- (8) Forelimb and hind limbs well developed. Powerful feet having thick pads below digits which possess sharp claws retractile into sheath.
- (9) Females give birth to 2-6 cubs. **Cubs** are weaned at 3 months. Cubs are taught upto 9 months for hunting techniques.
- (10) Lions **prey** includes grazing animals such as deer, buffalo, zebra, nealgai, sheep, goat and other wild beasts.

**Special features : Mightiest creature.** Fearsome and dangerous to animals and man. Sometimes becoming maneater. Only mutton eater. Fascinating animals of zoo, sancturaries and national parks. Lions live in family groups called **prides**.

**Identification :** Since the animal has majestic head and above features, hence it is *Felis leo*.

### 155. *Canis familiaris* : Dog

**Classification :** Same as that of *Erinaceus* upto infra-class.

Order..... Carnivora → Carnivorous

Genus..... *Canis*

Species..... *familiaris*

**Geographical distribution :** Cosmopoliton.

**Habit and habitat :** Mostly found around human dwellings. These days domesticated dogs are common.

**Comments :**

- (1) Commonly called as **Dog** or **Kutta**.
- (2) Body divided into **head, neck, back, chest** and **abdomen**. Animal measures.
- (3) Forelimbs and hind limbs almost of equal size.
- (4) Head small containing **nostrils, mouth, eyes** and **ear**.
- (5) **Mouth** wide. Often long fleshy **tongue** protruding. Respiration fast.
- (6) Colour of body brown, white, black, grey or spotted.
- (7) Female comes into heat once or twice a year, gives birth to 4-6 young ones.

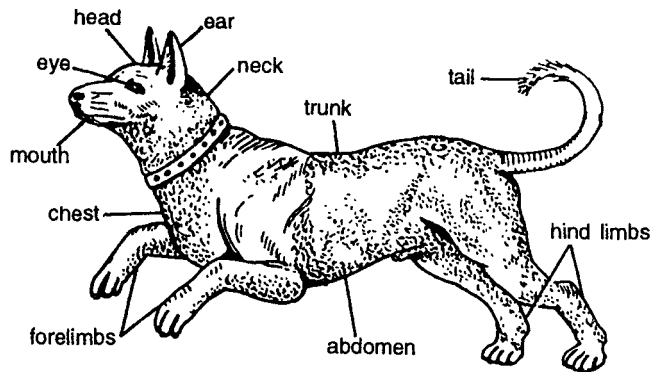

Fig. 155. *Canis familiaris* : Common dog.

**Special features :** (i) Dogs are carrier of a disease called as **Rabies or Hydrophobia**. It is a viral and zoonotic disease, that is, found both in man and animals. Whenever an infected dog bites man, it transmits rabies germs. Immediately HDC vaccine (human diploid cell vaccine), which is antirabies, should be given through intramuscular injections, 3 or 4 inoculations on alternate days. Untreated human rabies cases die. **Rabipura** is effect vaccine against dog bite cases, (ii) Dogs are used by man as watch dogs and also in tracing criminals because dogs have strong smelling power. In USA dogs are trained to diagnose exact place of tumour or cancer by their strong smelling power.

**Identification :** Dog is so familiar domesticated animal which is very commonly recognized.

### 156. *Malurus ursinus* : Sloth Bear

**Classification :** Same as in *Erinaceus* (upto Infra-class).

Order..... Carnivora → Carnivorous

Genus..... *Malurus*

Species..... *ursinus*

**Geographical distribution :** Found in India in tropical and temperate jungles.

**Habit and habitat :** Found in jungles. Carnivorous.

**Comments :**

- (1) Commonly called as **black bear**.
- (2) **Heavily** built body divisible into characteristic **head, neck, back, chest, abdomen** and **tail**. Almost no **tail**.
- (3) Body covered with dropping long and course black furs all over body including legs and feet, except snout.
- (4) Forelimb and hind limbs well developed. Feet broad and flat bearing large claws.
- (5) **Eyes** and **ears** small.
- (6) **Lower lip elongated**, tongue extensive and some of the teeth are rudimentary.
- (7) Males invariably larger than females.
- (8) Females give birth to 2-4 extremely small **cubs**. Females breed every second or third year.

**Special features :** Bears are usually non-offensive. In winter they sleep deeply and move very less. Kodiak bear is heaviest weighing 1600 pounds. Polar bears have **white fur** all over body.

**Identification :** Since the animal contains elongated lowerlip and above features, hence it is *Malurus*.

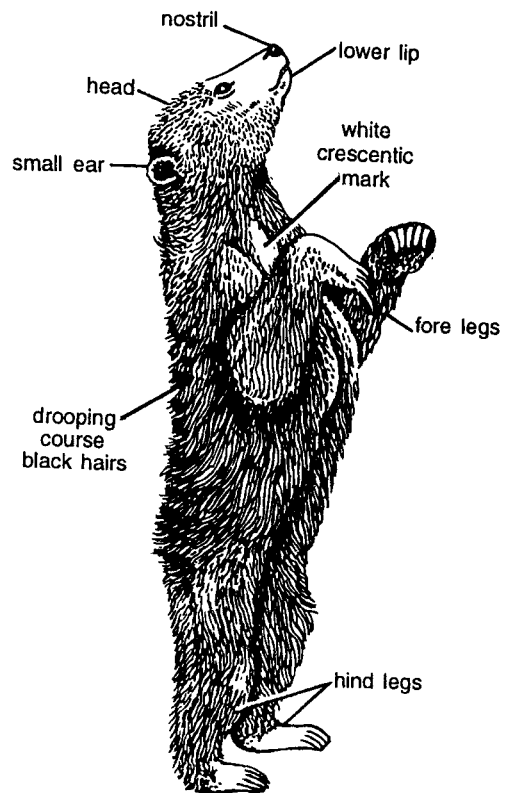

Fig. 156. *Malurus ursinus* : Sloth Bear.

### 157. *Acinonyx jubatus* : Cheetah

**Classification :** Same as in *Erinaceus* upto infra-class.

Order..... Carnivora → Carnivorous

Genus..... *Acinonyx*

Species..... *jubatus*

**Geographical distribution :** Cheetah mostly found in open savanas of Africa. From Asia their population has been eliminated except in Iran.

**Habit and habitat :** Live in grasslands.

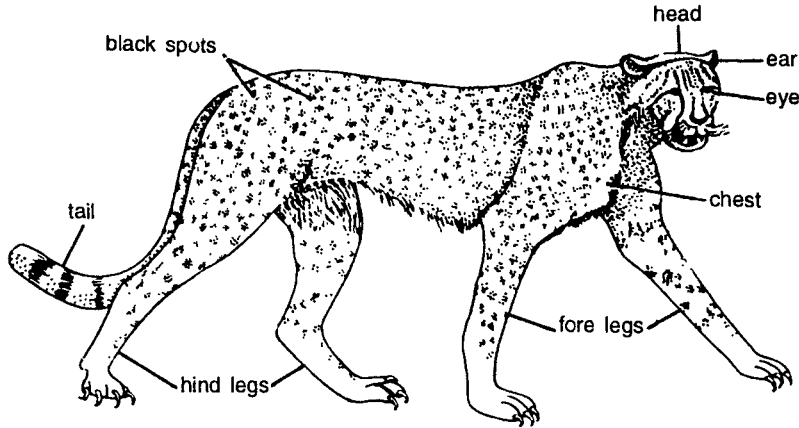

Fig. 157. *Acinonyx jubatus* : (Cetah).

**Comments :**

- (1) Commonly called as **Cheetah** or **Hunting leopard** (Fig. 157).
- (2) Body dog-like and divisible into **head, neck, back, chest, abdomen** and **tail**.
- (3) Females slightly smaller than males. Males measure 30 inches in length and weight 130 pounds.
- (4) **Head** small with a distinctive black stripe from the inner corner of each eye to the upperlip.
- (5) All over body there are **black spots**.
- (6) Forelimb and hind limbs comparatively larger. It walks on padded feet.
- (7) It preys on small birds and antelopes.
- (8) **Gestation** period of 84 to 95 days. Females give 2 to 4 cubs which are born with silvery mane which disappears when they are 2.5 months old.

**Special features.** Cheetahs are fast runner, capable of running 60 miles per hour to overtake and pull down their prey.

**Identification :** Since the animal has spotted body and all above features, hence it is **Cheetah**.

**158. *Hyaena* : Hyena**

**Classification :** Same as that of *Erinaceus* (upto Infra-class).

Order..... Carnivora → Carnivorous

Genus..... *Hyaena*

**Geographical distribution :** Found in Syria, Arabia, Africa and India.

**Habit and habitat :** Nocturnal, living in jungles.

**Comments :**

- (1) Commonly called as **Lakadbaggha**.
- (2) **Body** dog-like, divided into small **head, neck, trunk, chest, abdomen** and bushy tail. Head contains **mouth, nostril, snout, eyes** and ears.
- (3) It measures 1.5 meter in length.
- (4) **Colouration** of body greyish or yellowish and coloured stripes on trunk.

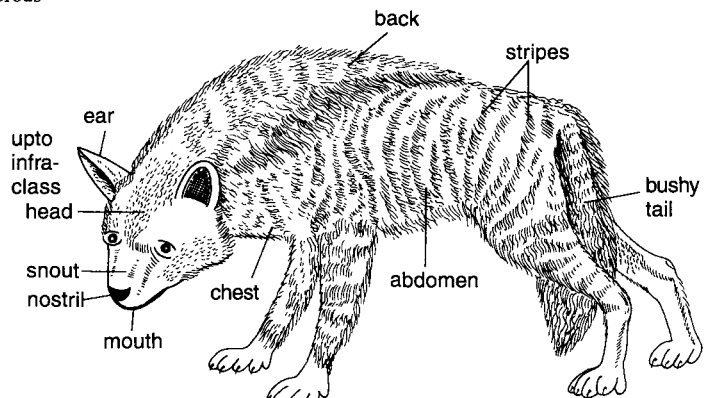

Fig. 158. *Hyaena*.

(5) Feet 4-toed, claws non-retractile. **Forelimbs** stronger than **hind limbs**.

(6) **Forelimb** paws are adapted for **digging**.

**Special features** : Hyena screams and laughs like human beings. It digs human caves and eats flesh of freshly burried body. **Hyena** is fearsome to village folks.

**Identification** : Since the animal contains striped and bushy tail and possesses above features, hence it is **Hyena**.

### 159. *Phoca* : Seal

**Classification** : Same as in *Erinaceus* (upto Infra-class).

Order..... Carnivora → Carnivorous

Genus..... *Phoca*

**Geographical distribution** : Found in arctic and antarctic regions.

**Habit and habitat** : Essentially marine but not completely aquatic like whales. They spend substantial part of their life-cycles ashore mainly for breeding.

**Comments** :

(1) Commonly called as **earless common seal** or **sea lion**.

(2) **Body** streamlined having more or less fish-like appearance. Body divisible into **head, neck, back, chest** and **abdomen**.

(3) Head contains mouth, **nostril** and **vibrissae**.

(4) Both forelimbs and hind limbs adapted for **swimming** and modified as **flippers** which act like oars. Feet webbed.

(5) Annual movement of seals starts towards warmer water. Earless seals have limited seasonal migration.

(6) Males larger than females.

**Special features** : Seals show some degree of **territorial behaviour**. Adult male fur seals arrive a month before at a breeding ground called as rookeries and establish a territory for females they copulate. Female gives birth to a **single** young seal. At seashore, seals by their play actions, amuse man and children. Other seals are eared seals, walrus seals and elephants seals.

**Identification** : Since the animal has webbed feet and above features, hence it is ***Phoca***.

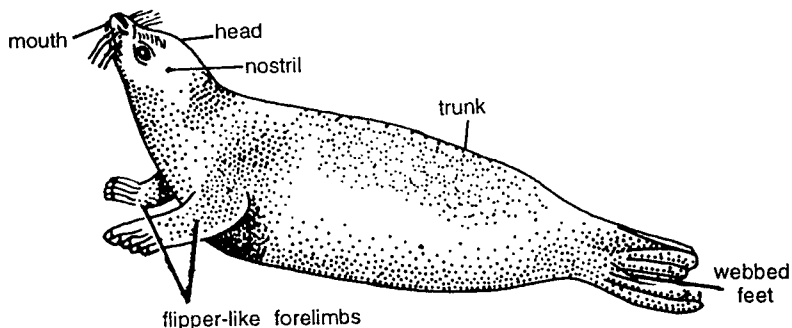

Fig. 159. *Phoca* : Seal.

### 160. *Platanista gangeticus* : Ganges Dolphin

**Classification** : Same as in *Erinaceus* (upto Infra-class).

Order..... Cetacea → Aquatic mammal. Forelimbs paddle like.

Genus..... *Platanista*

Species..... *gangeticus*

**Geographical distribution** : Found in Ganga and Brahmaputra rivers and their tributaries.

**Habit and habitat** : Aquatic.

**Comments** :

(1) Commonly called as **Ganges dolphin** or **Susu**.

(2) Body divisible into **head, neck, back, chest, abdomen** and tail.

(3) **Body** dark grey, streamlined, 2 to 3 meters long.

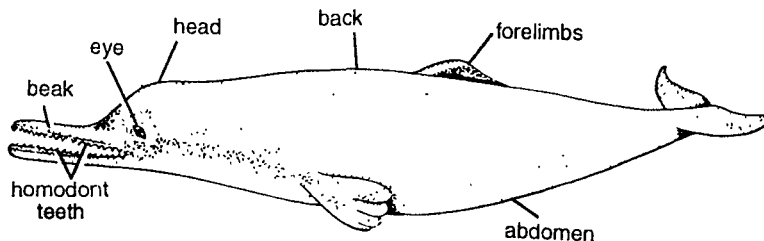

Fig. 160. *Pentania gangetica* : Ganges Dolphin.

- (4) **Tail** fish-like, tapering with 2 fleshy horizontal lobes.
- (5) **Forelimbs** are modified into broad paddle-like **flippers**. Hind limbs absent.
- (6) **Head** small. **Jaws** like large beaks of birds having about 200 homodont teeth in each jaw.
- (7) Dolphin probes in mud for shell-fishes.

**Identification** : Since the animal has elongated jaws and above features, hence it is **Ganges Dolphin**.

### 161. *Elephas maximus* : Elephant

**Classification** : Same as in *Erinaceus* (upto Infra-class).

Order..... Proboscidea → Nose and upper lip long muscular proboscis like.

Genus..... *Elephas*

Species..... *maximus*

**Geographical distribution** : All over world in past and especially found in India, Africa, Sri Lanka and Borneo. Eocene to Recent.

**Habit and habitat** : **Gregarious**, live in small and large **hordes** of 8-10 to many. Feeding on trees, tall grasses and bamboos. Inhabiting forests to semi-arid bush fields and from coastal plains to high mountain forests and cool Alpine meadows. Water requirement regular. Rarely away from source of water.

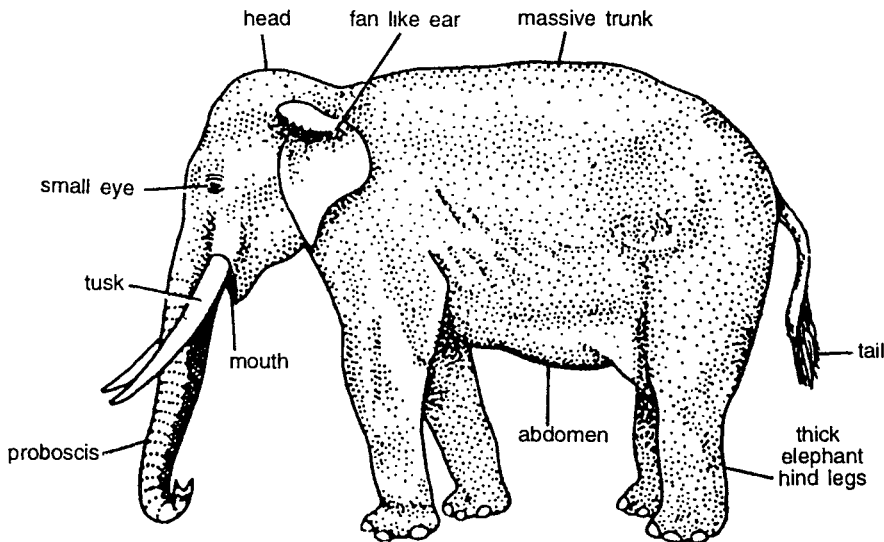

Fig. 161. *Elephas maximus* : Elephant.

**Comments :**

- (1) Commonly called as **Elephant or Hathi**. The most popular and powerful mammals.
- (2) Body massively built and divided into **head, short mobile flat neck, huge trunk, chest, abdomen and tail**.
- (3) Size 10-11 feet in standing height at shoulder. Body covered with grey or black coloured loose skin containing sparse hairs.
- (4) Large **head** contains **small eyes** and **broad ears**.
- (5) Characteristic feature is **proboscis** or **long trunk**. It is formed by **nose** and **upper lip** and has nasal passage and nostrils at tip. Proboscis or trunk serves as highly flexible arm enabling the elephant to lift food and water into mouth.
- (6) Two upper incisors are elongated as **tusks**. Molar tooth with transverse enamel rows for grinding.
- (7) **Legs pillar-like. Feet club-like. Toes 5**, each with small nail-like hoof. Weight is borne on elastic pads behind toes.
- (8) Sense of smell and hearing well developed. **Eye sight poor**. Tail is small.

**Special features :** Very useful to mankind. Man has used elephants in wars, for transport. Elephant's tusk is used to make handle of various articles and for ornamental purpose. Slowest breeder. Gestation period 22 months. Only one calf is born. Male elephant discharges a dark oily substance called **musth** from glands in the temple. Musth is discharged when level of testosterone in blood becomes high. At this time male elephant becomes very aggressive. Elephants provide solid evidence in favour of **organic evolution**.

**Identification :** Since animal has fan like ear, massive size and above features, hence it is **Elephant**.

## 162. *Equus caballus* : Horse

**Classification :** Same as that of *Erinaceus* (upto Infra-class).

Order..... Perissodactyla → Odd-toed hoofed mammals.

Genus..... *Equus*

Species..... *caballus*

**Geographical distribution :** Eocene to Recent. Found in Eurasia, Africa, and tropical America. Cosmopolitan.

**Habit and habitat :** Horses live in herds in open plains and grasslands. Wild Przewalski's horses live in deserts between Mongolia and China. Horses are domesticated. One of the fastest running animals.

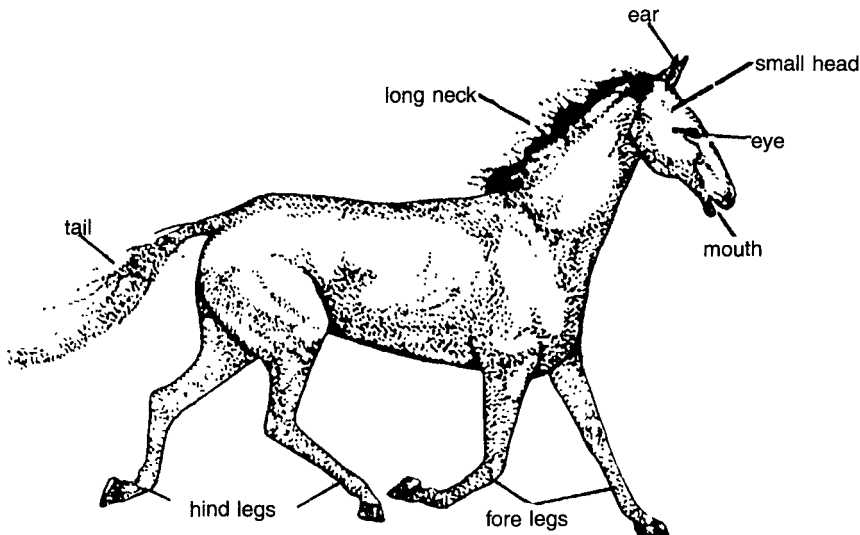

Fig. 162. *Equus caballus* : Horse.

**Comments :**

- (1) Commonly called as **modern horse**.
- (2) Horses support their entire body weight on the third toe of each foot. Other toes have atrophied to rudimentary **splints**. This is excellent adaptation for swift running on the open plains.
- (3) Body of horse is massively built and divided into **head, neck, trunk, chest, abdomen** and **tail**.
- (4) **Head** is small and characteristic. Teeth adapted for grazing and specialized for grinding coarse siliceous grasses. Jaws are elongated typically 'horse' like. Ears shorter.
- (5) **Neck** is long and mobile. Mane longer and pendant.
- (6) **Trunk** is large.
- (7) Each foot ends in a large hoof. Metatarsals and tarsals fused. Hind legs and fore legs well developed and adapted for fast running.
- (8) Tail is bushy completely covered with long hairs.

**Special features :** Horse shows following features—(i) Horse is a very familiar animal to man. (ii) It provides excellent evidence for organic evolution. It has been very useful animal to mankind, used in wars and transport, (iii) Horse racing is most commercial and amusing game. *Equus przewalskii* of Mongolia is the only surviving wild horse from which nearly 50-60 domesticated horses have been derived, (iv) Horse symbolizes truth and secrecy. Very familiar saying that from 'Horses mouth'. (v) Horse also symbolizes **strength or power** of heavy machines such **2 horse power, 5 horse power** etc. Horses also form part of Army for wars.

**Identification :** Since the animal has peculiar jaws and above feature, hence it is *Equus caballus*.

### 163. *Equus zebra* : Zebra

**Classification :** Same as in Horse.

Genus.....*Equus*

Species.....*zebra*

**Geographical distribution :** Most widely distributed in Kenya, South West Africa.

**Habit and habitat :** Creatures of open lands and grasslands. Mountain zebra found in arid and semi-arid lands. Practically kept in all zoological gardens.

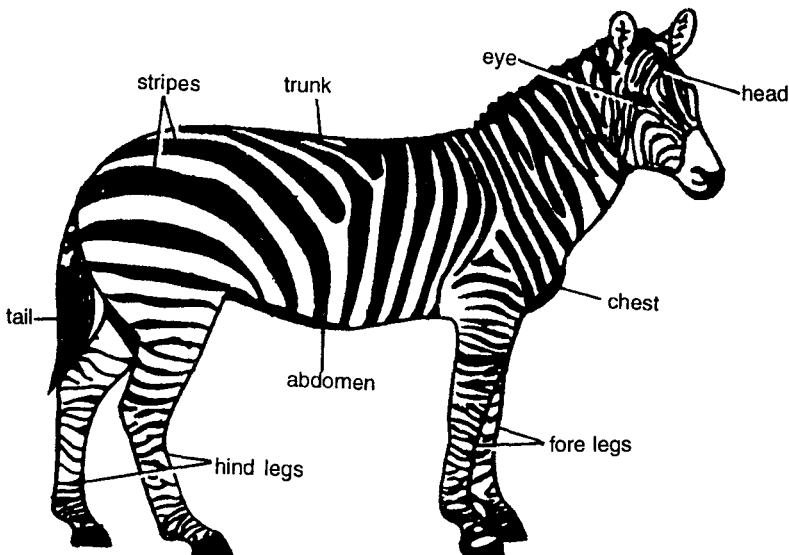

Fig. 163. *Equus zebra* : Zebra.

**Comments :**

- (1) Commonly called as **Zebra**.
- (2) Size like ass but body elegantly built.
- (3) Colour white or buff but fully **striped** with black or brown colour. These coloured stipes present all over the body.
- (4) Body divided into **head, mobile neck, trunk, chest, abdomen** and **tail**.
- (5) Head contains **jaws, mouth, ears** and **eyes**.
- (6) For safety, zebras rely on their keen eyesight and speed, but they can use their hooves and teeth for defense.
- (7) **Jaws elongated** like horse. **Teeth adapted for grazing**.
- (8) **Gestation** period 11 to 12 **months**. Give birth to a single **young** (foal).

**Special features :** Characteristic feature of zebra is that it can look fat and sleep even under poor conditions. Zebras generally remain confined to one place but they can migrate to safer places where food and water is in abundance. Spectacular migration occurs on the Sevengets plains of Tanzania where thousands of zebras and other animals migrate to fresh pastures.

**Identification :** Since the animal has coloured stripes and above features, hence it is **Zebra**.

### 164. *Equus hemionus* : Ass or Donkey

**Classification :** Same as in **Horse**.

Genus..... *Equus*

Species..... *hemionus*

**Geographical distribution :** Found in Runn of Kutch in Western India (Sandy coloured Indian wild ass), Mongolia (Rusty brown wild ass) and Syria (light fawn wild ass believed to be extinct now).

**Habit and habitat :** Found in grazing grassland and open plains. Wild asses prefer high plateaus for living.

**Comments :**

- (1) Commonly called as **ass** or **donkey**.
- (2) Relatively smaller than horse.
- (3) Body divisible into **head, neck, trunk, chest, abdomen** and **tail**.
- (4) Head larger. Jaws modified for grazing and more or less like horse. Head contains, **jaws, mouth, nostril, eyes** and **ears**.
- (5) Mane shorter and erect. Ears larger. Back bone very strong.
- (6) **Fore legs** and **hind legs** very stout and strong to carry load.
- (7) Hooves narrower. A bare callosity only on fore feet.
- (8) Only lower part of tail covered with long hairs.
- (9) Foot more hardy. Wild asses more susceptible to disease transmitted by livestock.

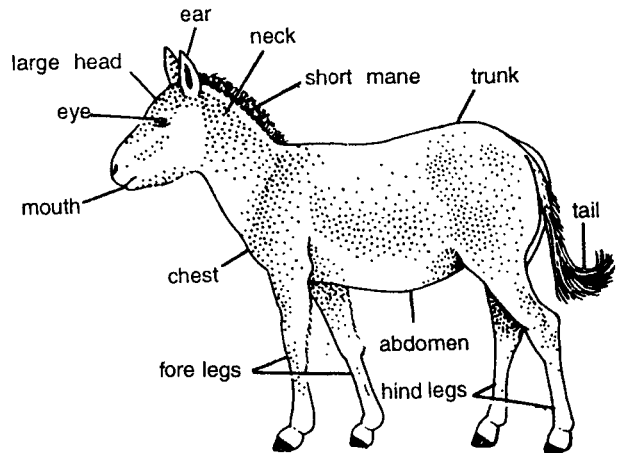

Fig. 164. *Equus hemionus* : Donkey or Ass.

**Special features :** Donkey has been used by man for **carrying loads** since long time. Competition with livestock for grazing and water drinking has lowered asses populations. Meat of wild ass is highly preferred. Hide is used as leather. Other parts of body have medicinal value. Donkey is not intelligent mammal. Often one person abuser others by saying '**Gadha**'. Dhobi (washermans) and donkey are often linked together.

**Identification :** Since the animal has short '**mane**' and above features, hence it is **Gadha** or **Donkey**.



## 165. *Rhinoceros*

**Classification :** Same as in **Horse**.

Genus.....*Rhinoceros*

**Geographical distribution :** Found in Africa, Java, Sumatra, and India. Africa (white or square-lipped Rhinoceros = *Cerathotherium simum*; Black or hook-lipped Rhinoceros = *Diceros bicornis*). India and Nepal (Black Rhinoceros = *Rhinoceros unicornis*).

**Habit and habitat :** While square-lipped rhinos are grassland grazer, Asiatic rhinos live in rain forests. Indian rhinos in swampy jungles at foot hills of Himalayas feed mainly on grasses and swamp succulent vegetation. Rhinos of Java and Sumatra are browsers. Fascinating animals of the zoological gardens.

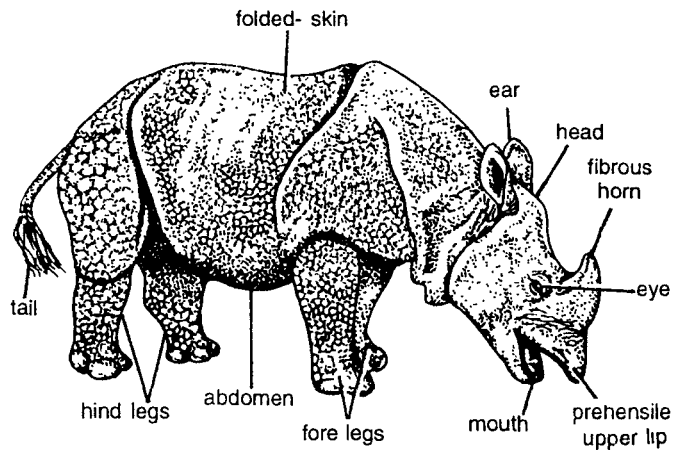

Fig. 165. *Rhinoceros*.

**Comments :**

- (1) Commonly called as *Rhinoceros* or **Genda**.
- (2) Large heavily built body with **thick armour-like hide** having considerable folds.
- (3) Skin folds contain various **tubercles** and usually without hairs.
- (4) Body divisible into **head, neck, large trunk comparatively small tail, chest and abdomen**. Head contains, **jaws, mouth, eyes, horn** and ears. Upper jaw in **prehensile**.
- (5) The maximum height is 6 feet and weight two and half tons.
- (6) Rhinos have characteristic **horns located** on snout rather than top of head. African rhinos, have **two horns** while **Indian rhinos only one horn**. Horn is made up of skin derivatives in the form of strong fibrous pointed structure.
- (7) Prime need of rhinos is water and mud. They (roll) in mud over their skin for cooling their skin and for protection from **biting flies**.
- (8) Solitary, swift and agile.
- (9) **Eyesight poor** but **smelling power strong**.
- (10) Gestation period 15 to 17 months. Single calf is produced.

**Special features :** All rhinos, particularly Asiatic species, are **endangered animals**. The reported power of powdered rhino horns as an **aphrodisiac**, making them astronomically valuable has led to killing of rhinos and their exploitation. Thick folds of skin is very strong and protective. '**Gende ki Khal**' is famous saying for thick skinned person.

**Identification :** Since the animal has thick folds of such and above features, hence it is *Rhinoceros*.

## 166. *Camelus dromedarius* : Arabian Camel

**Classification :** Same as in *Erinaceus* (upto Infra-class).

Order..... Artiodactyla → Even-toed hoofed mammals.

Genus.....*Camelus*

Species.....*dromedarius*

**Geographical distribution :** Old world animals mainly found in Arabian countries.

**Habit and habitat :** Desert dwellers.

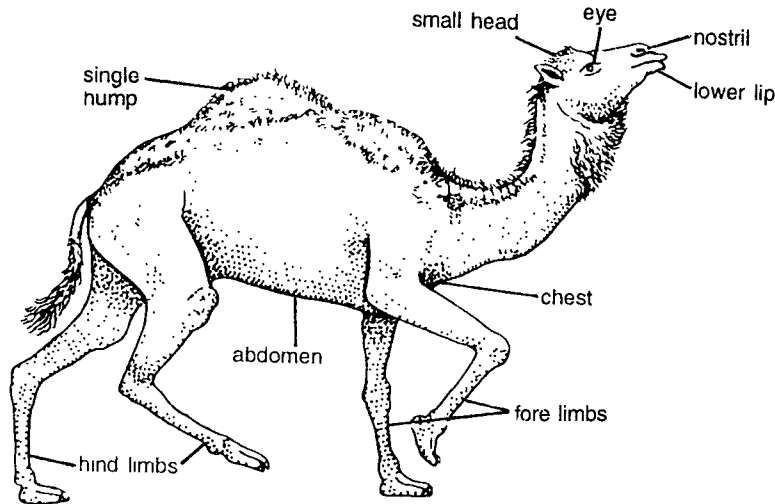

Fig. 166. *Camelus dromedarius*.

**Comments :**

- (1) Commonly called as **camel** or **Oont**.
- (2) Camels have attained highest height.
- (3) Body characteristic, divisible into **small head, thin and long neck, humped back (trunk) chest, abdomen** and **tail**. Generally neck and head remain in upright position.
- (4) **Head** contains eyes, small ears and slender snout containing a cleft on upper lip.
- (5) Hind limbs and fore limbs elongated and well developed.
- (6) Each foot contains **two toes**. Camels have characteristic **leathery pads** on foot which support body weight, provide nonskid surface for camels while climbing or walking on sand and also getting protection from hot sand.
- (7) Characterised by having one or two **humps** over back. Arabian camel has a **single hump**, while **Bactrian camel** has two humps.
- (8) **Stomach** is a complex organ having 4 chambers and enough space for storing water. They have efficient mechanism to utilize water and can go for 2 weeks without drinking water.
- (9) Avoid excessive loss of water by regulating their body temperatures.

**Special features :** Camels are useful domesticated animals. Used by man in deserts. They are still used for transport, in war and in army. In deserts camels form important means of transport. The decline in population of camels is due to excessive hunting and their exclusion from pastures and water.

**Identification :** Since the animal has **hump** and above features, hence it is **camel**.

**167. *Sus scrofa* (Pig) : Wild Boar**

**Classification :** Same as in **Camel**.

Genus..... *Sus*

Species..... *scrofa*

**Geographical distribution :** Found in New World as well as Old World.

**Habit and habitat :** Live in herds, inhabiting deserts to rain forests and on plains. Domesticated, gregarious, swimmers and fond of wallowing.

**Comments :**

- (1) Commonly called as **Wild boar** or **Jangali suar**. Males larger than females.

- (2) Body ugly-looking, divisible into small **head**, small **neck**, thick **trunk**, very small tail, chest, abdomen and short legs. Maximum height of one meter and weight approximately 200 kg.
- (3) Skin thick containing bristle-like hairs.
- (4) Head contains small **eyes**, small **ears** and snout. Snout is **flat**, and **disk-like**.
- (5) Upper canines turn upwards as **tusks**, besides a pair of lower tusks.
- (6) Fore legs and hind legs short and stout. **Four toes** on each foot, **only front toe functional**.
- (7) Stomach two-compartmented.
- (8) **Sense of smell** and **hearing well-developed**.
- (9) Tail of domestic pig is lifted and coiled.
- (10) Gestation period of 4 months. Females give 4-8 piglets.

**Special features :** Pigs provide very high protein food all over the world. Piggery industry has developed at commercial scale. Hairs of pig are used for making brushes. Pigs are scavengers. Although, they are vegetarian but in villages they eat human faeces. They act as intermediate host for *Taenia solium* of man.

**Identification :** Since the animal contains flat snout and all above features, hence it is **Wild boar**.

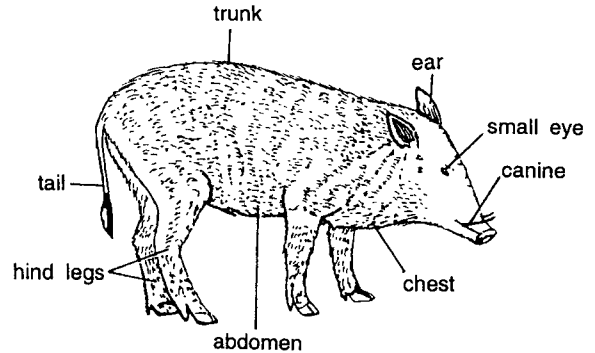

Fig. 167. *Sus scrofa* (Pig) : Wild boar.

## 168. *Giraffa camelopardalis* : Giraffe

**Classification :** Same as in **Camel**.

Genus.....*Giraffa*

Species..... *camelopardalis*

**Geographical distribution :** Found in Africa.

**Habit and habitat :** Found in grasslands containing thick population of trees. Basically browsers of brownish leaves of trees. Ruminant.

**Comments :**

- (1) Commonly called as **Giraffe**. Tallest animals which have excited man's curiosity since antiquity.
- (2) Male stands 4 to 6 metres in height. Females are little shorter 3.5 to 4.5 metres in height.
- (3) Body contains brownish spots over all parts.
- (4) Body divisible into **head**, **elongated neck**, **trunk**, **tail**, **chest** and **abdomen**.
- (5) Head small containing small eyes, **nostrils oblique ears** and **conical jaws**. Head in both sexes contains 3 to 5 small **horny horns** covered by -velvety skin.
- (6) Lips leathery. Tongue prehensile extending 1.5 feet in length.
- (7) **Neck** quite **elongated** reaching upto leaves of trees. Cervical vertebrae only 7.
- (8) Legs long. Giraffe's typically run by moving both legs on each side in unison. **Fore legs** longer than **hind legs**. To bend down they must spread their fore legs wide.
- (9) Giraffes can live for longer period without water but drink water regularly when available.

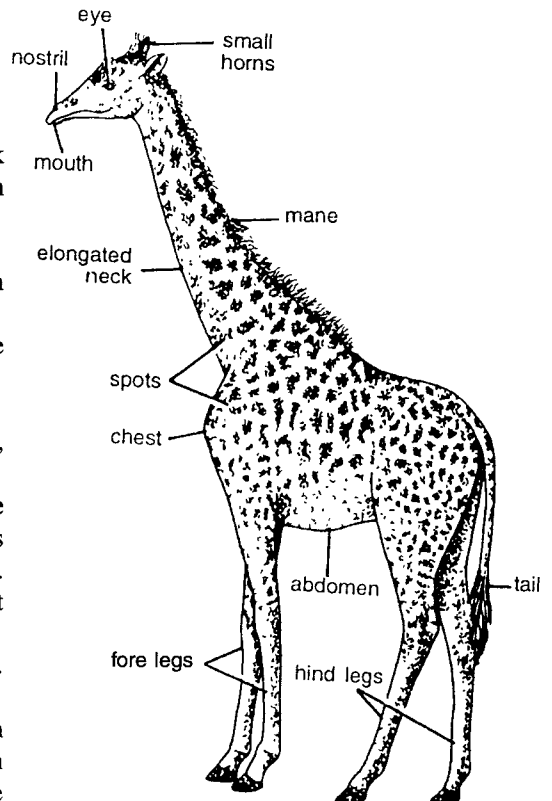

Fig. 168. *Giraffa camelopardalis*.

**Special features** : Most important example, given by Lamarck to explain his theory of organic evolution.

Giraffe's first defense is running. Their sounds limited to grunts and whistle-like sound. They are most vulnerable to attackers.

**Identification** : Since the animal has elongated neck and all above features, hence, it is **Giraffe**.

### 169. *Ovibos moschatus* : Musk Ox

**Classification** : Same as in Camel.

Genus..... *Ovibos*

Species..... *moschatus*

**Geographical distribution** : Asia and Tundra.

**Habit and habitat** : Adapted for living in colder region (Tundra). Gregarious. Ruminant.

**Comments** :

- (1) Commonly called as **Musk ox**.
- (2) Bulls height at shoulder approximately is 1.5 metres. Body divisible into **head**, **neck**, **trunk**, and a short **tail**. The ox weigh's approximately 300 to 400 kg.
- (3) Head large containing **eyes** on sides and a pair of **curved** and **pointed massive horns** both in male and female mouth and nostril.
- (4) **Body covered** by a **thick** and **shaggy coat** of long hairs hanging the legs upto hooves. Tail covered under coat.
- (5) Move with speed. Fore leg hind leg stout.
- (6) Musk oxen eat grasses, hedges and browse on willows, lichens, mosses and bark.
- (7) Females give birth to a single calf.
- (8) Fur traders killed hundreds and hundreds of musk oxen for sports material and food. This has led to decline of their population.

**Special features** : Broad hooves enable musk ox to move over snow. As defense against wolves to protect their calves, they form a ring around calves standing shoulder to shoulder.

**Identification** : Since the animal has long shaggy black hairs and above features, hence it is **Musk ox**.

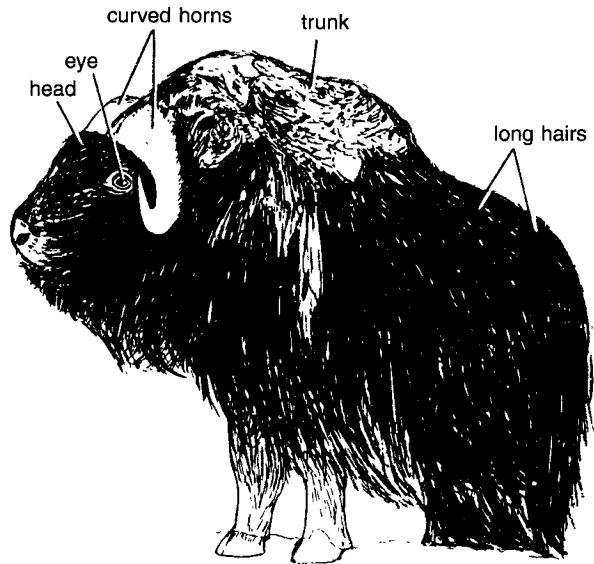

Fig. 169. *Ovibos moschatus* : Musk Ox.

### 170. *Ovis* : Sheep

**Classification** : Same as in Camel.

Genus..... *Ovis*

**Geographical distribution** : Cosmopoliton in India, USA, New Zealand, Mexico, Australia, Yugoslavia and USSR.

**Habit and habitat** : Found in grassy grazing areas. Highly domesticated. Gregarious. live in herds. Ruminant.

**Comments** : (1) Commonly called as **sheep**.

- (2) Body covered with characteristic woolly fur of high economic value.
- (3) Body divisible into **head**, **neck**, **trunk**, **tail**, **chest** and **abdomen**.

- (4) Head contains **eyes, nostrils, ears** and a pair of hollow ringed and backwardly curved horns. Mouth has teeth adapted for grazing.
- (5) Stand approximately one meter in length.
- (6) Generally whitish fur.
- (7) Forelimbs and hind limbs shorter. Hooves are divided.
- (8) Female gives birth to only one lamb.
- (9) Sheep harbour plenty of protozoan and helminthic parasites.

**Special features :** Sheep is of high economic return animal. Sheep industry is one of the most important animal products industry. **Mutton, milk, leather, wool, medicines,** etc. on which man depends.

**Identification :** Since the animal has wool covering entire body and above features, hence it is **Sheep.**

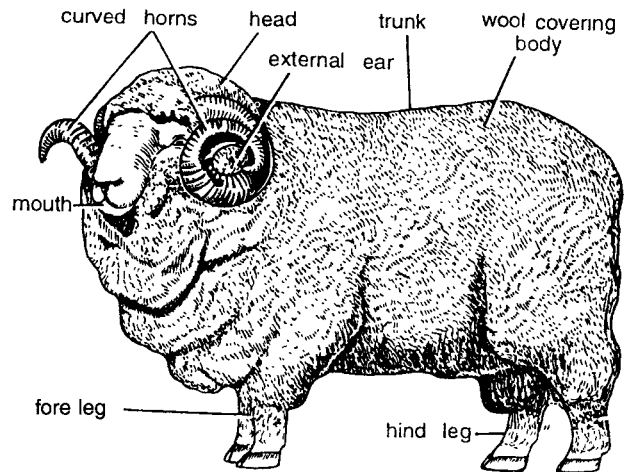

Fig. 170. *Ovis* : Sheep.

### 171. *Moschus moschiferous* : Musk Deer

**Classification :** Same as in Camel.

Genus.....*Moschus*

Species.....*moschiferous*

**Geographical distribution :** Found in equatorial rain forests of Africa. Distributed in India and Malaysia.

**Habit and habitat :** Elusive, solitary and nocturnal, living very close to water. Good swimmers. Prefer to live in high mountain forests and bursh lands. Shy animals, active mainly at dusk and dawn.

**Comments :**

- (1) Commonly called as **Musk deer.**
- (2) Body very elegant with maximum height 20 inches. Body divisible into **head, neck, trunk, chest, abdomen** and **tail.**
- (3) Head is small containing conical snout, small **eyes,** and **erect ears** and **nostril.**
- (4) Upper canines of male strongly developed forming tusks upto 8 cms long which protrude below jaw and used for fighting.
- (5) Mature males contain an **abdominal musk gland** which secretes a waxy substance, called as **Kasturi,** used in medicines and perfumes.
- (6) Even-toed ruminants. They chew cud.
- (7) Fore legs and hind legs well developed.

**Special features :** Musk deers are famous for Kasturi. Kasturi is a very costly item. For Kasturi musk deer are hunted.

**Identification :** Since it contains '**musk gland**' and all above features, hence it is **Musk deer.**

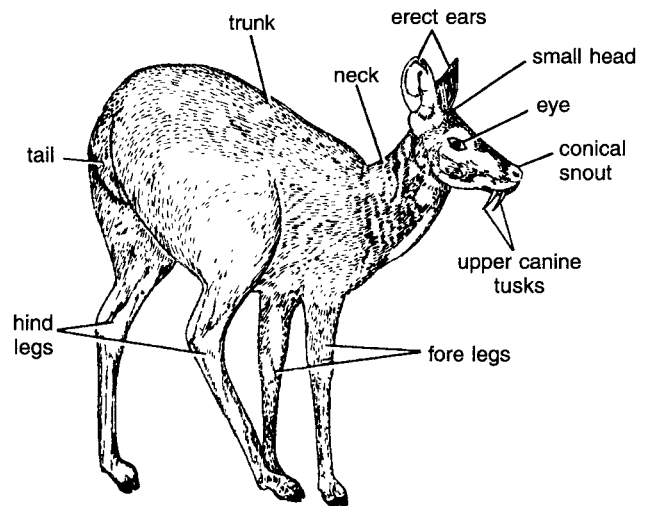

Fig. 171. *Moschus moschiferous* : Musk Deer.

# Wonder Vertebrate Animals

# 3

The chordates (vertebrates) have wonderful records being the largest, heaviest, fastest, smallest, found deepest, etc. from fishes upto mammals. Classwise description of such records has been given below :

## Fishes

**Largest marine fish.** Whale-shark (*Rhineodon typicus*) first discovered in 1821, South Africa. It is not, however, the largest animal. It measures about 15 to 20 meters in length and weighs about 40 tonnes.

**Largest marine carnivorous fish.** Great white shark (*Carcharodon carcharias*) measuring 11 metres in length. It is also called as maneater, found in tropical and sub-tropical waters.

**Longest marine bony or true fish.** Russian sturgeon (*Acipenser huso*) which measures about 8 meters in length.

**Largest fresh-water fish.** *Pangasianodon gigas* found in Thailand. It measures about 2.5 meters in length and weighs about 175 kg.

**Heaviest bony fish.** Ocean sunfish (*Mola mola*), measuring about 4 to 5 meters and weighing about 2300 kg.

**Smallest marine fish.** Goby (*Eviota zonura*) of Marshal Island which measures 1 cm to 1.5 cms.

**Shortest fresh-water fish.** Shortest recorded fresh-water fish and shortest of all vertebrates is the dwarf pygmy goby, *Pandaka pygmaea*. It measures 0.7 cm to 1 cm. It is almost transparent and colourless, found in streams and lakes of Philippines.

**Fastest fish.** Sailfish, *Isiophorus platypterus*. Although exact speed is difficult to record but it is supposed to travel 30 meters in 3 seconds. The four-winged flying fish has a speed of approximately of 65 k.p.h.

**Longest lived fish.** Lake sturgeon, *Acipenser fulvescens*, of Ontario, Canada, was believed to be 154 years old according to growth ring count.

**Shortest lived.** Certain African Killifish live not more than 8 months in the wild state.

**Found deepest.** *Bassagigas* reported in 1970 from a depth of about 8300 meters by U.S. research vessel.

**Most venomous.** Stonefish found in tropical waters of Indo-Pacific. Neurotoxin of its spines on contact sometimes proves fatal.

**Maximum eggs producing.** *Mola mola*, an ocean fish produces 300,000,000 eggs at one time.

## Amphibians

**Largest salamander.** Giant Chinese salamander *Megalobatrachus* measuring about 100 cm in length and weighing about 10 to 12 kg.

**Largest newt.** Ribbed newt *Pleurodeles waltl* measuring about 40 cm in length.

**Largest frog.** *Rana goliath* of West Africa measures 80 to 85 cm in length with extended legs and weighs about 3 kg.

**Largest tree frog.** *Hyla vosta* found in West Indies Islands.

**Largest toad.** *Bufo marinus* found in South American sea water.

**Smallest newt.** *Notophthalmus perstriatus* of South-Eastern United States. It measures about 5 cm in length.

**Smallest toad.** *Bufo taitanus beiranus* discovered in 1906 near Mozambique, East Africa.

**Smallest salamander.** Pygmy salamander. *Desmognathus wright* of U.S.A. It measures 5 cm in length.

**Longest lived.** Longest age of 55 years recorded in giant male Japanese salamander, *Megalobatrachus japonicus*.

## Reptiles

**Largest and heaviest reptile.** Salt water crocodile, *Crocodylus porosus*, of Australia, Asia and New Guinea. A notorious man-eater (1823) measured 8 meters in length and weighed about 2000 kg.

**Smallest reptile.** A gecko (*Sphaerodactylus parthinopion*) found in Island of Virgin Gorda. It measured about 4.0 cm.

**Fastest reptile.** Race runner *Cnemidophorus sexlineatus* which runs at the speed of 30 k.m.h.

**Largest chelonion.** Pacific leatherback turtle (*Dermochelys coriacea*) measuring 2 to 2.5 meters in length and weighing about 300 to 360 kg.

**Longest lived chelonion.** Tortoises are the longest lived of all vertebrates. *Testudo Carolina* was supposed to live for 138 years.

**Longest and heaviest snake.** *Eunectes murinus* of South America (1944). It measured about 12 meters in length and weighed about 450 kg.

**Shortest snake.** Thread snake *Leptotyphlops bilineata* found in Caribbean Islands. It measures about 10 to 12 cm.

**Most venomous snake.** Sea snake *Hydrophis belcheri* which has venom lethal one hundred times more than that of Australian taipan.

## Birds

**Largest bird.** North African ostrich *Struthio camelus*. Male bird stands 4 meters tall and weighs approximately 150 to 175 kg.

**Smallest bird.** Cuban Humming bird. Measures about 3 cm in length and weighing about 20 gm.

**Largest wing span.** Albatross *Diomedea exulans* has largest wing span of 3 meter.

**Most abundant bird.** Red bird quela (*Quelea quelea*) of drier parts of Africa. It has a population of 10,000 millions of which a tenth are destroyed each year by pest control units.

**Longest lived bird.** According to reports from Moskovskii zoologichesteei park, a male *Vulture gryphus* lived for 72 years.

**Fastest flying bird.** The spine-tailed swift which has recorded air speed of 95 k.p.h.

**Fastest wing beat.** Humming bird has fastest record of wing beat, 90 beats per second.

**Slowest wing beat.** Is that of vultures.

**Fastest swimmer.** Gentoo penguin, *Pygoscelin papua*. Swims at a speed of 35 k.p.h.

**Longest flights.** Arctic tern *Sterna paradisaea* migrated 12,000 miles. It was banded at a nesting on 5 July, 1955 in the Kamdalaksha sanctuary on white sea coast of U.S.S.R., north of Archangel and was captured alive by a fisherman 13 km. South of Fremantle Western Australia on 16 May, 1956.

**Most airborne.** Common swift *Apus apus* remains aloft atleast 9 months a year.

**Longest incubation.** In wandering albatross incubation period varies from 75 to 82 days.

**Most feathers.** Whistling swan *Cygnus columbianus* was found to have 25,216 feathers.

**Largest turkey.** Greatest live weight recorded for Turkey is 35 kg.

**Most talkative bird.** It is a male African gray parrot owned by *Ms. Lyn Logue* of Golden Green England.

## Mammals

**Commonest mammal and commonest animal.** Man is the most common animal. Maximum earth's surface is shared by human beings.

**Most valuable animal.** Thorough bred race horses are the most costly and valuable.

**Largest and heaviest mammal.** Blue whale measuring about 28 to 30 meters. Its tongue and heart weighed 2 kg and 700 kg respectively.

**Largest terrestrial animal.** African bush elephant, *Loxodonta africana*. It stands 3.5 meters and weighs about 7 tons.

**Smallest mammal.** It is savils white toothed pigmy shrew (*Suncus ctruscus*).

**Fastest mammal.** The fastest of all land mammals is hunting leopard or cheetah of East Africa.

**Slowest mammal.** Three-toed sloth *Bradypus tridactylus* of tropical America.

**Tallest mammal.** Giraffe (*Giraffa*).

**Longest gestation period.** That of Asiatic elephant *Elephas maximus*, for 2 years and 30 days.

**Shortest gestation period.** That of *Diadelphis marsupialis* (American opossum) for 8 to 13 days.

**Youngest breeder.** Streaked tenrec of Madagascar a large insectivore starts breeding in 5 days after birth.

## Carnivores

**Largest.** Kodiak bear measuring 8 feet from nose to tail.

**Largest feline.** Siberian tiger *Panthera tigris* weighs approximately 270 to 300 kg with height 39 to 42 inches at shoulder.

**Smallest feline.** *Felis rubiginoses*, the rusty spotted cat of South India and Sri Lanka.

## Chiroptera

**Largest.** *Pteropus vampyrus* is the largest bat. Its wing span measures about 1.5 to 1.75 meters.

**Highest detectable pitch.** Because of their ultrasonic echo-location, fruit bats can hear frequencies as high as 150,000 cycles per second (20,000 cycles per second for adult man).

## Primates

**Largest.** The largest living primate is the eastern lowland gorilla found in Zaire and Uganda.

**Smallest.** It is the lesser mouse lemur *Microcoebus murinus* of Madagascar. It measures about 12.5 to 15 cm in length.



# 4

## Preparation of Fixatives, Stains and Other Reagents

### Fixatives

The following fixative agents are in use for fixing various kinds of tissues :

**1. Bouin's fluid (alcoholic).** Dissolve 1 gm of picric acid in 250 cc of 90% alcohol. The Bouin's fluid or alcoholic picric acid is used to fix the tissues for microtomic sections. The alcoholic Bouin's fluid is removed from tissues by washing with 70% alcohol.

**2. Bouin's fluid (aqueous).** It is prepared by adding excess of picric acid in a measured distilled water. Decant the saturated picric acid fluid. The aqueous Bouin's fluid is used to fix the tissue with the elements *in situ*. Picric acid is removed from tissues by washing with distilled water.

**3. Corrosive sublimate.** It is prepared by adding 10 gm of corrosive sublimate to 3 cc of glacial acetic acid and 300 cc of distilled water.

This fixative is removed from tissues by washing with 70% alcohol. Tissues are fixed within few seconds to 10 minutes.

**4. Formalin solution.** 0.5 to 0.1% or 5% solution of formalin is prepared. Formalin acts both as fixative as well as preservative.

### 5. Trichloro-acetic acid.

Sublimate solution	6 cc
Trichloro acetic acid	1 cc
Acetic acid	1 cc

This fixative is one of the best decalcifying fluid.

### 6. Formol-picric-trichloro-acetic acid.

Formalin (40%)	15 cc
Trichloro-acetic acid	0.5 gm
Alcoholic picric acid solution (2% picric acid in 50% alcohol)	85 cc

### 7. Chromo-aceto-osmic acid.

#### (a) Weak formula.

Chromic acid	0.25%
Osmic acid	0.1% in water
Glacial acetic acid	0.1%

This fluid is good for smaller animals.

#### (b) Strong formula.

Chromic acid (1%)	15 cc
Osmic acid (2%)	4 cc
Glacial acetic acid	1 cc

Stock solution is prepared and mixed at the time of use. This fluid is good for large objects.

### 8. Formol-acetic-alcohol (F.A.A.).

Formalin (40%)	10 cc
Glacial acetic acid	5 cc

Ethyl alcohol (70%) 85 cc  
F.A.A. fluid is good for fixing nematodes and plant material.

**9. Henking fluid.**

Water 80 cc  
Glycerine 16 cc  
Fromic acid 3 cc  
Osmic acid (1% ) 1 cc  
Dahlia 0.4 cc

**10. Acetic sublimate.**

Corrosive sublimate 6 gm  
Distilled water 100 cc  
Glacial acetic acid 2 cc

**11. Chromo-acetic acid (Flemming solution).**

Chromic acid 0.2 to 0.25% in distilled water.

Acetic acid 0.1%

**12. Picro-formol.**

Picric acid saturated aqueous solution 75 cc  
Formol 25 cc  
Acetic acid 5 cc

**13. Zenker's fluid.**

Water distillate 10 cc  
Potassium dichromate 2.5 gm  
Mercuric chloride 5 gm  
Sodium sulphate 1 gm  
Glacial acetic acid 5 cc

This fixative is good for delicate objects.

**14. Mayer's albumen.**

White of egg 20 gm  
Glycerine 50 cc  
Sodium salicylate 1 gm

Mix the reagents, stir and filter. This is used to stick microtomy ribbons and small microorganisms, protozoans, etc. over slide.

**15. Carnoy's fluid I.**

Glacial acetic acid 1 cc  
Absolute alcohol 3 cc

This fluid is good for animal as well as plant material.

**16. Carnoy's fluid II.**

Glacial acetic acid 1 cc  
Chloroform 3 cc  
Absolute ethyl alcohol 1 cc

This fixative is recommended for animal tissues and flower buds. The alternative proportions given are also tried and instead of acetic acid propionic acid may also be taken.

**Stains (Dyes)**

The following stains are in use in a biological laboratory :

Borax carmine, eosin and haematoxylin are commonly employed for single and double staining, which can be prepared by the following methods :

**1. Borax carmine.**

Borax 4 gm  
Carmine 3 gm  
Distilled water 100 cc  
70% alcohol 100 cc

First dissolve 4 gm of borax in 100 cc of distilled water. Add 3 gm of carmine to borax solution. Boil the above solution for 30 minutes. Allow to stand for 2 to 3 days and stir occasionally. Measure the prepared solution and mix with equal volume of 70% alcohol. Allow to stand for 1 hour and then filter.

Borax carmine is mainly cytoplasmic stain and it is always better to overstain the tissues and then de-stain to rose petal colour or bright red colour.

**2. Eosin.** Dissolve 0.5 gm of eosin in 100 cc of ether, 70% or 90% of alcohol. It is also a cytoplasmic stain and is used in double staining along with haematoxylin.

**3. Ehrlich's acid and haematoxylin.**

Haematoxylin 2 gm  
Absolute alcohol 100 cc  
Glycerine 100 cc  
Glacial acetic acid 10 cc  
Alum in excess.

Dissolve 2 gm of haematoxylin in 100 cc of absolute alcohol. Add 10 cc of glacial acetic acid. Add 100 cc of glycerine. Add 100 cc of water.

Allow the mixture to stand in the light for maturation for about 5 to 10 days until it assumes dark red colour. Keep the mouth of the bottle closed with cotton plug and occasionally stir the solution. Haematoxylin is a nuclear stain.

**4. Delafield's haematoxylin.**

Haematoxylin 4 gm  
Absolute alcohol 25 cc  
Alum in excess  
(saturated solution) 400 cc  
Glycerine 100 cc  
Methyl alcohol 100 cc

Mix 4 gm of haematoxylin with 25 cc of absolute alcohol and then add it to 400 cc of saturated solution of ammonium alum. Leave the mixture in an open bottle for 3 or 4 days after which filter and add 100 cc of glycerine and 100 cc of methylated alcohol. Allow the solution to stand until the solution becomes dark coloured. Filter and use.

#### 5. Picro-indigo carmine.

Alcoholic picric acid saturated sol. in 90% alcohol 1 part  
Indigo carmine saturated sol. in 70% alcohol 2 parts

This stain is good for staining hard and chitinous structures.

#### 6. Safranin.

Safranin 1 gm  
Distilled water 100 cc

This dye or stain is used to colour the plant tissues.

#### 7. Acid fuchsin.

Acid fuchsin 0.5 gm  
Distilled water 100 cc

This stain is good for chitinous tissues.

#### 8. Leishman stain.

Leishman stain 0.15 gm  
Absolute alcohol 100 cc

This dye is good for protozoans.

#### 9. Mallory's triple stain. Solution A.

Acid fuchsin 10 gm  
Distilled water 100 cc

#### Solution B.

Aniline blue 0.5 gm  
Orange G 2.0 gm  
Phosphomolybdic acid 2.0 gm  
Distilled water 100 cc

#### Solution C.

Phosphomolybdic acid 2.0 gm  
Distilled water 100 cc

This stain is good for microtomy sections. Stain the sections in solution A for 30 seconds. Then wash in distilled water for 2 minutes, and again stain in solution B for 1 to 5 minutes, wash in distilled water for 1 to 2 minutes, dehydrate and mount.

#### 10. Light green.

Light green stain 0.82 gm  
90% alcohol 100 cc

This is a good plasma stain.

#### 11. Fast green.

Fast green stain 1 gm  
90% alcohol 100 cc

This is a cytoplasmic stain.

#### 12. Aceto-carmine stain or propionic carmine.

Glacial acetic acid  
or propionic acid 45 cc  
Distilled water 55 cc  
Carmine powder 0.5 to 1.0 gm

Mix 45 cc of glacial acetic acid or pure propionic acid with 55 cc of distilled water. Heat to boiling and add 0.5 to 1.0 gm of carmine. Shake well, cool and filter.

This is one of the most commonly used stain for chromosomal studies.

#### 13. Aceto-orecin.

Glacial acetic acid 45 cc  
Distilled water 55 cc  
Orecin stain 1 gm

Because of deterioration in dilute acid, the stain is best kept as 2.2% stock solution in glacial acetic acid which can then be diluted to 45% when required. This is also a cytological stain good for chromosome studies.

## Cytological Regents

For cytological studies, animals are first dissected in physiological salines.

#### 1. For cold-blooded animals.

##### (a) NaCl solution. NaCl analytical

Reagent (A.R.) 0.64 gm.  
Distilled water 100 cc

##### (b) Ringer's solution.

NaCl 0.65 gm  
KCl 0.025 gm  
CaCl<sub>2</sub> 0.03 gm  
NaHCO<sub>3</sub> 0.02 gm  
Distilled water 100 cc

#### 2. For warm-blooded animals.

##### (a) NaCl solution

NaCl solution 0.9%  
Normal saline 0.78%

##### (b) Ringer's solution.

NaCl 0.85 gm  
KCl 0.025 gm  
CaCl<sub>2</sub> 0.03 gm  
Distilled water 100 cc

### Other Reagents

Besides fixatives and stains, the following reagents are needed for preparing slides.

**1. Normal saline.** Dissolve 0.78% of sodium chloride (Analytical) in 100 cc of distilled water.

**2. Acid alcohol.** Add 1 drop of concentrated hydrochloric acid (HCl) in 100 cc of 70% alcohol.

**3. Acid water.** Add 1 drop of concentrated HCl to 100 cc of distilled water.

**4. Grades of alcohol.** 30, 50 and 70% alcohols are prepared from 90% or absolute alcohol by adding desired distilled water.

30% alcohol : Add 206.22 cc of distilled water to 100 cc of 90% alcohol.

50% alcohol : Add 84.71 cc of distilled water to 100 cc of 90% alcohol.

70% alcohol : Add 31.05 cc of distilled water to 100 cc of 90% alcohol.

# 5

## General Method of Microscopic Preparations

### Microscopic Preparations of Slides

The larger specimens, such as prawn, pila, cockroach, fishes, amphibians, reptiles, birds, and mammals are preserved in preservatives like formalin or alcohol for the study of their external features and they do not need any elaborate process. Microscopic study may be done by **temporarily** or **permanently** mounting the organism on the slide. Temporary mounts can be made in water, glycerine or Iugol's iodine solution. For example, living *Cyclops*, *Amoeba*, *Paramecium*, etc. are kept on slide in a drop of water, a coverslip is put over the object and thus it can be examined under the microscope. For clarity of structures of small animals, microorganisms and histological studies of tissues, an elaborate technique is employed for making their permanent preparations. These smaller objects are mounted in balsam on a slide. There is a series of processes by which a living organism or its tissue is made fit for microscopic examination in a permanent state. The utility of permanent preparations is that the animal cell or tissue remains as such without undergoing major changes. The method of permanent preparation includes :

- (1) Killing and narcotization.
- (2) Fixing.
- (3) Washing.
- (4) Staining.
- (5) De-staining or removal of excess of stain.
- (6) Dehydration or removal of water.
- (7) De-alcoholization or clearing.
- (8) Mounting on slide.
- (9) Labelling.

#### [I] Killing and narcotization

The first step in permanent preparation is killing instantaneously in order to prevent the change in form of the object as it had in living condition and immediately fixing the object. Sometimes killing is preceded by **narcotization**. The narcotics used are chloroform, menthol, ether, alcohol, acetone and chloroform, etc. The purpose of narcotization and killing is important so as to have the same form and chemically constructed tissue or organism as it had during its lifetime. In certain cases in smaller animals, killing is done by heating. In the case of the whole mounts and micro-organisms, certain chemicals like **corrosive sublimate**, bring about killing and fixation simultaneously.

**[II] Fixing**

Fixing is done with various fixative agents for histological elements. Fixing is essential in every type of microscopic preparations either for sections or for whole mounts and also in larger specimens. The function of fixation is manifold.

- (1) The tissues become hard and the hardening resists further post-mortem changes.
- (2) Fixative agent coagulates and renders insoluble the elements of tissues which may not be dissolved in further processing.
- (3) The fixative agent renders insoluble the various constituent elements of cells, alters their refractive indices and thus makes them optically differentiated under the microscope.

Various **fixative agents** generally used are **absolute alcohol, 90% alcohol plus glycerine, picric acid, corrosive sublimate, formol, osmium tetroxide and nitric acid** with or without water.

**[III] Washing**

Washing is essential as by this process the uncombined and excess of fixative agent is removed. The presence of fixative agent in tissues or cells will inhibit good staining. The washing agent depends upon the type of fixative agent used. As picric acid in water is removed by water, picric acid in alcohol is removed by 70% alcohol. Formol and corrosive sublimate are washed with water distillate. Sublimate is washed in alcohol.

**[IV] Staining**

The tissues or cell components are stained in various dyes. The dye makes the tissues distinct in its histological sphere. The various dyes are **Orange G., Bordeaux red, sudans, congo red, Alizarine oxyquionine, methylene blue, neutral red, borax carmine, haematoxylin, picro-indigo carmine, eosin and Gower's carmine**. Mainly two kinds of stains are used :

- (1) **Nuclear stains** which stain nuclear parts of the cell, such as Delafield's or Ehrlich's haematoxylin.
- (2) **Cytoplasmic stains** such as borax carmine, picro-indigo carmine, Gower's carmine and eosin, etc., which stain cytoplasm.

For general and whole mount staining borax carmine is used. Aqueous stains are prepared in water, whereas alcoholic stains are prepared in alcohol. When a single stain is used the process is called as **simple** or **single staining**. In some cases two stains, *i.e.*, nuclear and cytoplasmic, are used and this process is called as **double staining**.

**[V] De-staining**

The removal of excess of stain is called as **de-staining**. De-staining agents are acid alcohol or acid water. The acid alcohol is used with alcoholic stains, while acid water is used with aqueous stains. Alcoholic stains are those which are made in alcohol such as Borax carmine. Aqueous stains are those which are made in distilled water such as Haematoxylin.

**[VI] Dehydration**

This process is meant for removal of water from the tissues. The dehydration prevents putrefaction or decaying and maintains the same shape and size of tissues or cells. The moisture or water in tissues absorbs various germs of destructive nature so that the tissue may be destroyed, hence the necessity of dehydration. Dehydration is done by passing the mounting material through various grades of alcohol such as 30, 50, 70, 90 and 100% alcohols. The tissue is soaked in gradually increasing strengths of alcohol. The lower grades of alcohol, such as 30, 50 and 70% alcohols, are prepared either from 90% or absolute alcohol. The dehydration is carried out in corked or glass-stoppered tubes.

**[VII] De-alcoholization or clearing**

After dehydration, transparency in tissues is obtained by treating with a clearing agent which removes alcohol and makes the tissue clear and transparent. The clearing agents are cedar wood oil, clove oil, xylol and benzol, etc. Xylol is most commonly employed and it makes the tissues hard and brittle. Clove oil is a superior clearing agent specially in the whole mounts. It also possesses a higher index of refraction than balsam mounting media.

**[VIII] Mounting**

Mounting marks the end of permanent preparation. The choice of mounting media is not much but they should have the same refractive index as that of the cleared tissue. The refractive index of such a stained, dehydrated and cleared cell is  $N = 1.54$ . Canada balsam has almost the same refractive index. Mounting is an easy process. The tissue is kept over glass slide in a drop of balsam and coverslip is lowered slightly. After mounting, the slide may be kept for drying in a hot chamber. The excess of balsam on the slide, as generally happens with beginners, should be removed with cotton soaked with xylol or 90% alcohol. This should be done when the balsam has dried. For much better finishing the edge of the coverglass may be ringed with a cement such as gold size or a varnish. The air bubbles present in balsam under cover glass should be removed by gentle heating. Now D.P.X. is used as mounting media instead of Canada balsam.

During all the chemical bathing of tissues, two changes of each reagent are necessary. The time of keeping tissue in various reagents may vary from 5 to 15 minutes.

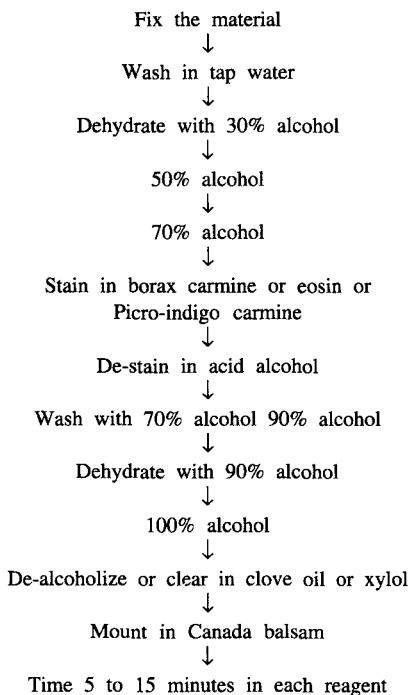
**I. Chart for single staining****[IX] Labelling**

After mounting the slides are labelled. Preferably use printed labels or make the labels from ordinary paper. Write over the label the name of the animal or mount, date, time and your name.

- (1) The articles, such as slides, coverslips and instruments should be perfectly cleaned.
- (2) The working place should be kept in order.
- (3) During dehydration the tissues should be kept in tightly-closed cork or glass-stoppered tubes. The opened tube will spoil material by absorbing moisture from atmosphere. Even breathing closely with dehydrating tube is undesirable.
- (4) The change of solution should be done very quickly, reducing time of exposure to atmosphere to minimum.
- (5) The chemicals used once should not be reutilized.
- (6) The Canada balsam used should be clean, dust-free and not viscous.

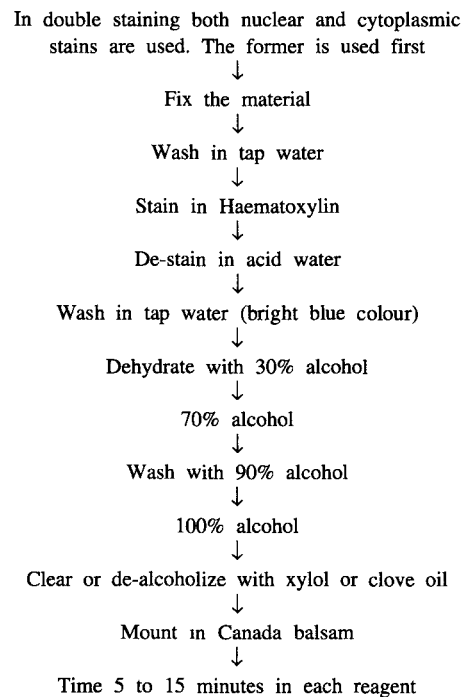
**II. Chart for double staining**

# Microtomy

# 6

For studying histological, histopathological and histochemical details of the organs and tissues thin paraffin sections are cut with a **Microtome**. The process is called as **Microtomy**. For proper diagnosis of certain diseases, microtomy is very helpful. Rather some diseases can only be diagnosed properly if thin well-stained paraffin sections are available. Most of the biopsy tests (examination of tissues) can be performed through **microtomy**. By this method tissue is made fit for microscopic examination.

Microtomy includes the following steps :

- (1) Animals and tissues for microtomy.
- (2) Narcotisation of animals.
- (3) Fixing of tissues.
- (4) Washing of tissues.
- (5) Dehydration of tissues.
- (6) Clearing or dealcoholization of tissues.
- (7) Embedding of tissues.
- (8) Block making.
- (9) Trimming of blocks.
- (10) Section cutting.
- (11) Double staining, dehydration, clearing and mounting.
- (12) Microscopic study.
- (13) Microphotography (if desired).

**1. Animals and tissues for microtomy.** Frog, black rats and white or albino rats are favourite animals for microtomy. Various tissues of these animals are used for histological studies. Earthworms can also be used to cut sections in order to study invertebrate histology.

**2. Narcotisation of animals.** Take a medium size frog. Chloroform it in a large jar. Wet some cotton in chloroform and put in the jar containing frog. Close the mouth of jar with glass cover. After 15 to 20 minutes, when fully anaesthetized, take out the frog and keep it in a dissecting tray. Make a longitudinal incision in abdomen to expose viscera.

**3. Fixing of tissues.** Take cleaned 100 c.c. wide-mouthed glass-stoppered bottles. In each bottle keep about 50 cc of aqueous Bouin's fluid. Now take out liver, lung, tongue, stomach and intestine and keep them in separate bottles for 30 minutes. From each bottle, after half an hour, make 2 to 3 cm rectangular pieces of each organ, and again keep them in their respective bottles for 24 hours.

The above tissues can be fixed in alcoholic Bouin's fluid also. Mostly for research purposes, tissues are fixed in alcoholic Bouin's fluid.

It is very essential to fix the tissues in fixative agent. Fixation serves 3 functions :



- (1) Fixative renders **hardness** to tissues to resist further **postmortem changes**.
- (2) Fixative agent **coagulates and renders** the elements of tissues insoluble so that cellular substances may not be washed away.
- (3) Fixative agent alters the **refractive indices** of tissues and makes them **optically differentiated** under the microscope.

**4. Washing of tissues.** After 24 hours take out the pieces of tissues and keep in a beaker. Tie the mouth of the beaker with a thin cloth and keep it under slow running tap water. Keep on washing under tap water till all the picric acid is removed. The indication of complete removal of picric acid comes when no yellowish water is seen. Normally, it takes 24 hours for perfect washing. Tissues fixed in aqueous Bouin's fluid are washed with tap water. While those fixed in alcoholic Bouin's fluid are washed with 70% alcohol. While washing with 70% alcohol, change it frequently till the yellow colour disappears.

**5. Dehydration of tissues.** Take one or two pieces of any organ in a staining tube and dehydrate through distilled water →30% alcohol →50% alcohol →70% alcohol →90% alcohol →100% alcohol. In each grade of alcohol keep tissues for 5 minutes with 2 changes. Dehydration removes water to prevent putrefaction. The graded alcohol gradually replaces water in tissues.

**6. Dealcoholization or clearing of tissues.** Clearing or dealcoholizing agents are **cedar wood oil** or **xylene**. Although cedar wood oil is better but because of its high cost, xylene is used.

Removal of alcohol from tissues is done through clearing agent. Take xylene in a staining tube and transfer tissue in it from 100% alcohol. Keep in xylene for 15 minutes till the tissue becomes transparent. Don't leave tissue in xylene for longer period otherwise it would become fragile. Now tissues are ready for embedding.

**7. Embedding of tissues.** Depending on melting point of wax, adjust the oven at 58°C or 60°C. Take wax with ceresin instead of plain wax. Keep flakes of wax in a beaker of 100 cc in oven 4 to 5 hours before embedding. In another beaker keep some wax plus xylene. Now take the tissue from xylene and first keep it in the beaker containing

xylene + wax for 30 minutes. Then transfer the tissue in pure melted wax for embedding for 1 to 2 hours. Normally double time is given for embedding than the time required by tissue to sink at bottom in xylene.

**8. Block making.** Make blocks either in metal L-shaped angles or in paper boat or in cavity blocks. 'L' pieces are preferred. First apply little glycerine on their internal surface. Pour melted wax at bottom of rectangular cavity formed by two 'L' pieces. Then add tissue and more melted wax to fully cover the tissue. Keep L pieces in a trough. Add water around them. As the melted wax is solidified, flood it with tap water. After cooling, the block comes out from 'L' pieces or remove L pieces. Because of glycerine 'L' pieces don't stick with wax. During block-making, see that no air bubble comes. If there are some air bubbles remove them with hot spatula.

**9. Trimming of blocks.** Trim the wax around the embedded material and make a perfect rectangular block. On one side keep sufficient space in the block for fixing it on a block holder. Apply half an inch wax layer over block holder.

**10. Section cutting.** The blocks are cut either by **rocking microtome** or **rotatory microtome** at 6 microns ( $\mu$ ) thickness. Ribbons are kept over Mayer's albumen coated slides. Keep clean slides ready. Apply pin head Mayer's albumen over the slide and rub it by last finger. Mayer's albumen helps in sticking the sections over glass surface. Keep 2 to 4 rows of sections depending upon the breadth of the sections. Ribbons should be kept upto more than half of the slide. Space should be left for putting labels over the slide. Flatten the section over a hot brass plate. The temperature of the hot plate should be nearly 40-45 degree. Add few drops of water below ribbons. As the water is heated ribbons become expanded by semi-melting of the wax. Sections should not be separated. Never do flattening over spirit lamp as in most of the cases wax melts and sections are burnt. After all the sections and ribbons become flattened, drain off water and leave the slide at room temperature overnight for drying the ribbons. Mark the ribbon side by glass marking pencil.

**11. Double staining, dehydration, clearing and mounting.** Double staining is applied. Haematoxylin

and eosin stain nucleus and cytoplasm of the cells respectively. Take individual slide and first keep it in xylol to remove wax for 5-10 minutes. Wax is dissolved in xylene and sections are left free. Now pass the slide in **descending series** of alcohols 100% → 90% → 70% → 50% → 30% → distilled water. After rinsing in distilled water stain the slide in **haematoxylin** for 2-5 minutes. Take out slide and again dip in distilled water. Then immerse the slide in a beaker containing tap water. The sections turn blue because of alkalinity of water. Observe the slide under microscope. If stain is dark, then immerse the slide in acid water and quickly immerse in tap water. Now dehydrate the slide through **ascending series** of 30, 50, 70 and 90% alcohols. After 90%, immerse the slide in alcoholic eosin for 30 seconds. Wash eosin in 90% alcohol. Then keep slide in 100% alcohol for 5 minutes and then in xylol for 15 minutes. Mount the slide in D.P.X. Keep ready the following descending and ascending series of stains and grades of alcohols in separate coupling jars.

**12. Microscopic study.** A good stained slide reveals pinkish colour of cytoplasm and blue colour of nuclei.

**13. Microphotography.** The slides meant for research may be microphotographed. For microphotography slide must be nicely stained.

#### Descending series

Slide  
↓  
Xylene  
↓  
100% alcohol  
↓  
90% alcohol  
↓  
70% alcohol  
↓  
50% alcohol  
↓  
30% alcohol  
↓  
Distilled water  
↓  
Ascending series

#### Ascending series

Distilled water  
↓  
Haematoxylin  
↓  
Distilled water  
↓  
Tap water  
↓  
Acid water  
↓  
30% alcohol  
↓  
50% alcohol  
↓  
70% alcohol  
↓  
90% alcohol  
↓  
alcoholic eosin  
↓  
90% alcohol  
↓  
100% alcohol  
↓  
Xylene  
↓  
Mount in D.P.X.

# 7

## Preparation of Permanent Stained Slides (Mountings)

### Instructions for Permanent Mountings

- (1) Study thoroughly about the structure which is to be stained and mounted.
- (2) Dissect the animal to take out the structure to be mounted (*e.g.*, neural complex of *Herdmania*) and follow the method given in Chapter 5.
- (3) After mounting, study and draw the slides prepared by you with the help of the Practical Book.

### A. PROTOCHORDATES

**1. Procedure :** From **Protochordates** and Vertebrates generally various mounting materials are taken out from the **formalin** preserved specimens. For example pharyngeal wall of *Herdmania* and striated muscles from **frog**. First dissect out the animal and take out the desired mounting materials. Follow the following procedure :

1. Wash the material in tap water for removing the formalin  
↓
2. Wash in distilled water.  
↓
3. Keep in 50% alcohol for dehydration.  
↓
4. Keep in 70% alcohol for dehydration.  
↓
5. Stain in **borax carmine**.  
↓
6. Wash in 70% alcohol.  
↓
7. De-stain in acid alcohol if excess stain.  
↓
8. Wash in 70% alcohol.  
↓
9. Keep in 90% alcohol for dehydration.  
↓
10. Keep in 100% alcohol for dehydration.  
↓
11. Keep in xylol for clearing or de-alcoholization.  
↓
12. Mount in D.P.X.

**Instructions :**

- (1) Keep the material in above reagent for 5 minutes and give 2 changes in each.
- (2) If the mounting material is already in 70% alcohol, then directly stain in Borax carmine.
- (3) After staining and mounting study and draw the slides prepared by you with the help of this book.
- (4) After mounting let the slide become dry for 24 hours and then study under microscope.

## 1. *Salpa*, *Doliolum* and *Amphioxus* : Whole Mount

For permanent mount wash, stain, dehydrate, clear and mount in D.P.X. on one slide using rectangular coverslip.

**[I] *Salpa*****Comments :**

- (1) It is a highly modified peculiar tunicate showing polymorphism and existing in two phases (i) Oozoid or asexual phase, and (ii) Blastozoid or sexual phase.
- (2) Typical oozoid consists of branchial and atrial openings, nerve ganglion, sub-neural gland, dorsal lamina, pharynx, endostyle peripharyngeal and retropharyngeal bands, muscle bands, muscles gill slits, visceral nucleus, mantle, test and test processes.
- (3) Stolon produces chain of buds.
- (4) Sexual and asexual stages alternate.

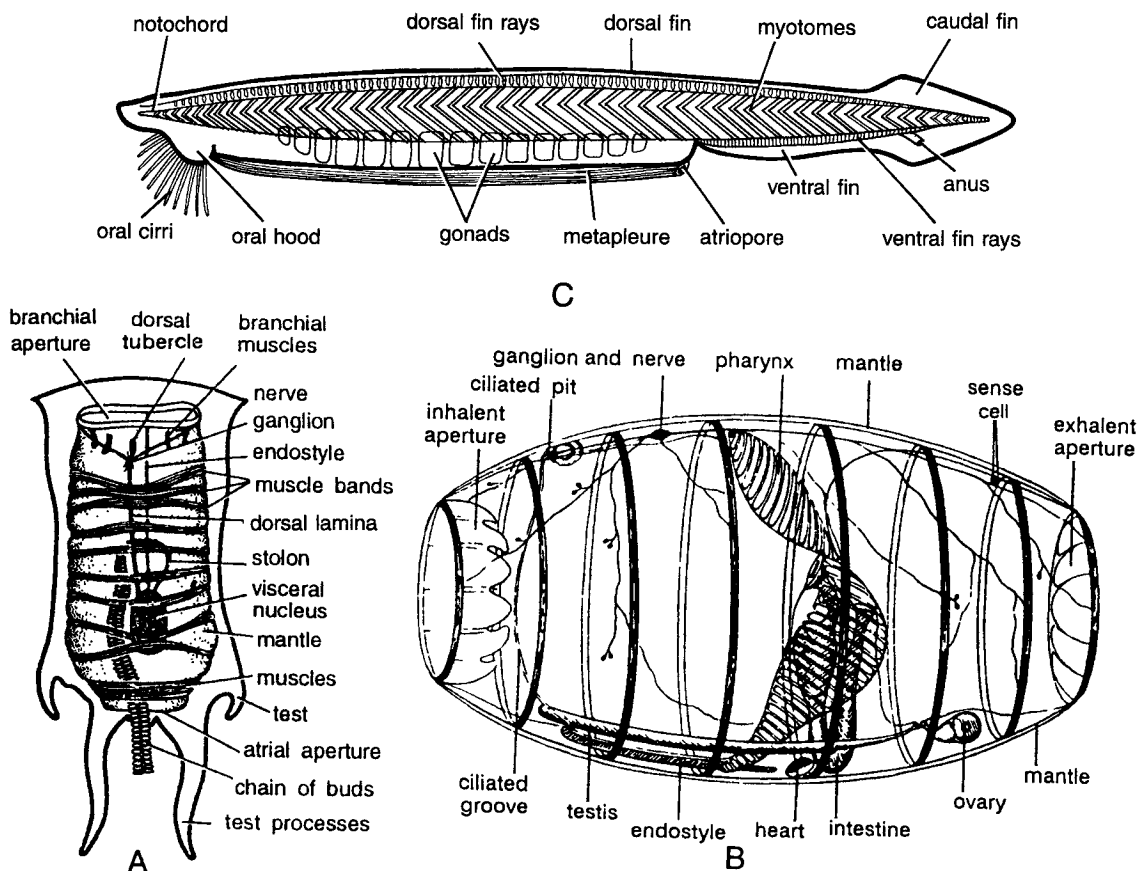

Fig. 1. Whole mount : A. *Salpa*, B. *Doliolum*, C. *Amphioxus*.

## [II] *Doliolum*

### Comments :

- (1) Commonly called as chain tunicate.
- (2) It exists in two phases (i) **Gonozooid** or **solitary phase** and (ii) **Oozooid** or **gregarion phase**.
- (3) Oozooid is barrel shaped covered by test.
- (4) **Branchial** and **atrial** openings maric the end of barrel.
- (5) Various structures seen are **test**, **anus** **mantle**, **muscle bands**, **stomach**, **intestine**, **endostyle**, **pharynx**, **testis**, **ovary**, **nerve** atrial opening, **mantlc**, **branchial aperture**, **peripharyngeal band**, **nerve ganglio**, **stigmata**, **visceral nerve** and **heart**.

## [III] *Amphioxus* or *Branchiostoma*

### Comments :

- (1) Commonly called an lancelet.
- (2) Simplest chordate measuring 5 cm in length.
- (3) Body elongated and pointed at both each.
- (4) **Dorsal**, **ventral** and **caudal fins** are low and continuous.
- (5) Various structures seen are dorsal fin rays, dorsal fin, **notochord**, **myotomes**, **atriopore**, **metapleure**, **gonads**, **oral hood** and **oral cirri**.

**Identification :** Chains of zooids in *Salpa*, muscle bands in *Doliolum*, **Oral hood** in *Amphioxus* and their above features respectively prove that they are *Salpa*, *Doliolum* and *Amphioxus*.

## 2. *Amphioxus* : T.S. Passing Through Oral Hood

Take out oral hood, wash in water, stain in borax carmine, dehydrate and mount in Canada balsam. Edge of **oral hood**, **skeletal rods** and **sensory papilla** an also seen in the section.

### Comments :

- (1) It is the anteriormost structure containing 10 to 11 pairs of **oral cirri** or **buccal tentacles**.
- (2) It leads into vestibule, which in turn opens into pharynx through **velum**.

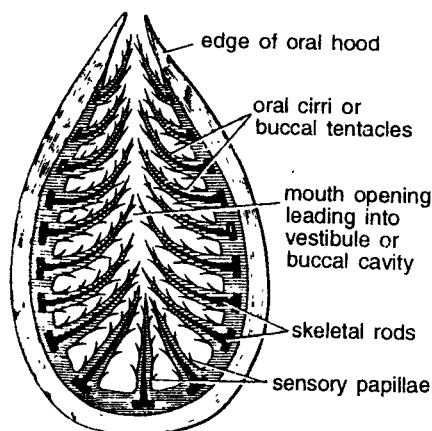

Fig. 2. *Amphioxus* : T.S. passing through Oral hood.

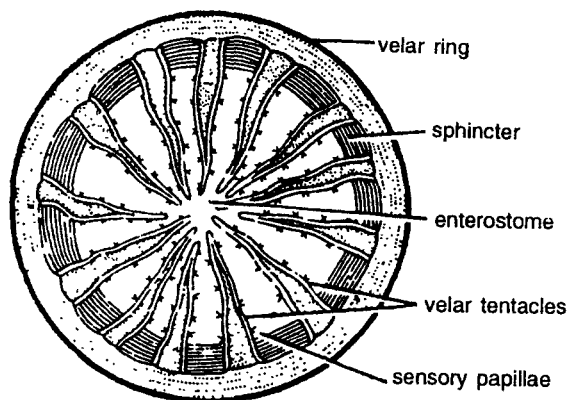

Fig. 3. *Amphioxus* : T.S. of passing through Velum.

## 3. *Amphioxus* : T.S. Passing Through Velum

Dissect from ventral side Velum is found at the base of vestibule. Wash, stain in borax carmine, dehydrate, clear and mount.

**Comments :**

- (1) Velum is composed of **velar ring**, **sphincters** and about 12 backwardly directed **velar tentacle** having **sensory papillae** and **cilia**.
- (2) Velum forms a sieve-like structure. In centre is **enterostome**.

**4. Amphioxus : Pharyngeal Wall**

Cut a portion of pharynx, wash in water, stain in borax carmine, dehydrate and mount. The pharynx contains dorsal fin rays, myotomes, nervecord, notochord and outer pharyngeal wall comment.

**Comments :**

- (1) Pharyngeal wall contains outer pharyngeal wall.
- (2) Other structures seen are dorsal fin rays, myotomes, nerve cord and notochord.

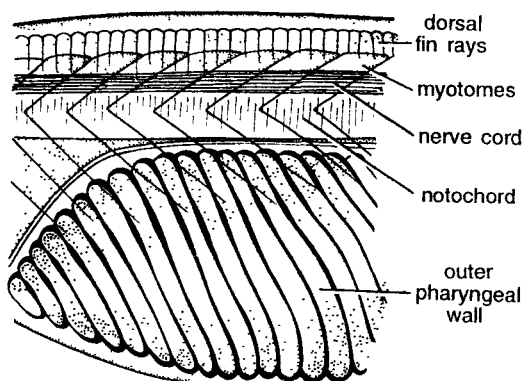

Fig. 4. *Amphioxus* : Pharyngeal wall.

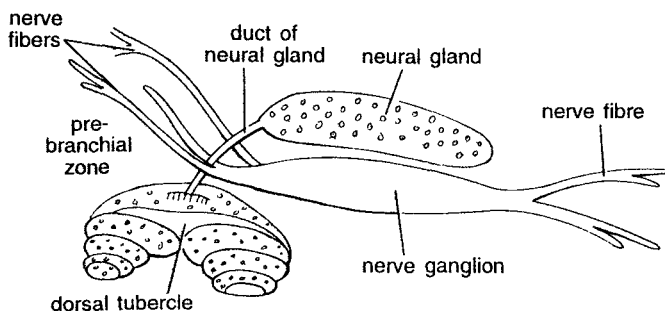

Fig. 5. *Herdmania* : Neural complex.

**5. Herdmania : Neural Complex**

Neural complex is embedded in body wall in the middle of inter-siphonal region. Take out neural complex by needles, wash, stain in borax carmine, dehydrate clear and mount.

**Comments :**

Neural complex is composed of neural gland, duct of neural gland which opens into dorsal tubercle and nerve ganglion. Nerve ganglion gives to nerve fibers to dorsal tubercle (Fig. 5).

**6. Herdmania : Spicules**

Take a piece of test, boil it in KOH, decant, wash, dehydrate clear and mount.

**Comments :**

Three kinds of spicules are seen in *Herdmania*, namely microscleres, pipette-shaped and spindle shaped. All these three types contain **rings of spines**.

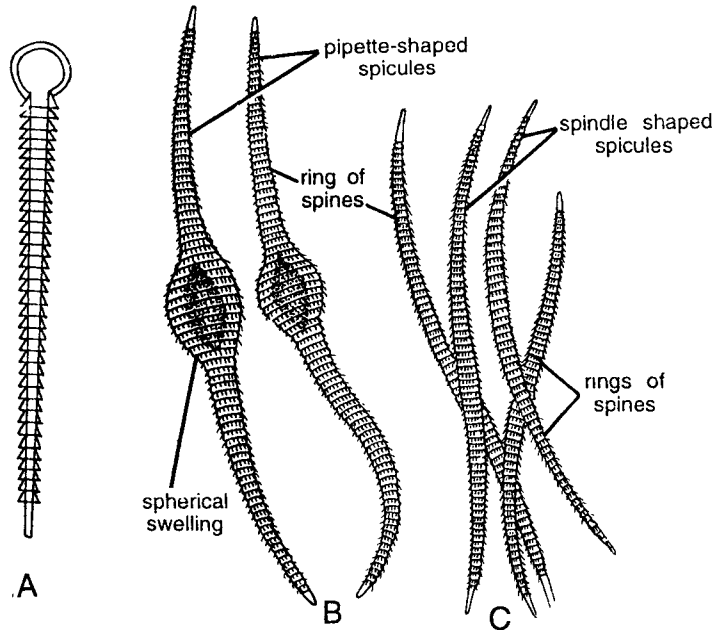

Fig. 6. *Herdmania* : Spicules A. Microscleres, B. Pipett-shaped, C. Spindle shaped.

## 7. *Herdmania* : Pharyngeal Wall

Remove the test, cut a piece of pharynx, bleach in chlorinated water so that brownish wall becomes whitish, stain in borax carmine, dehydrate clear and mount.

### Comments :

- (1) The wall is perforated by several **pores** or **stigmata**, through which water passes into atrial cavity from branchial cavity.

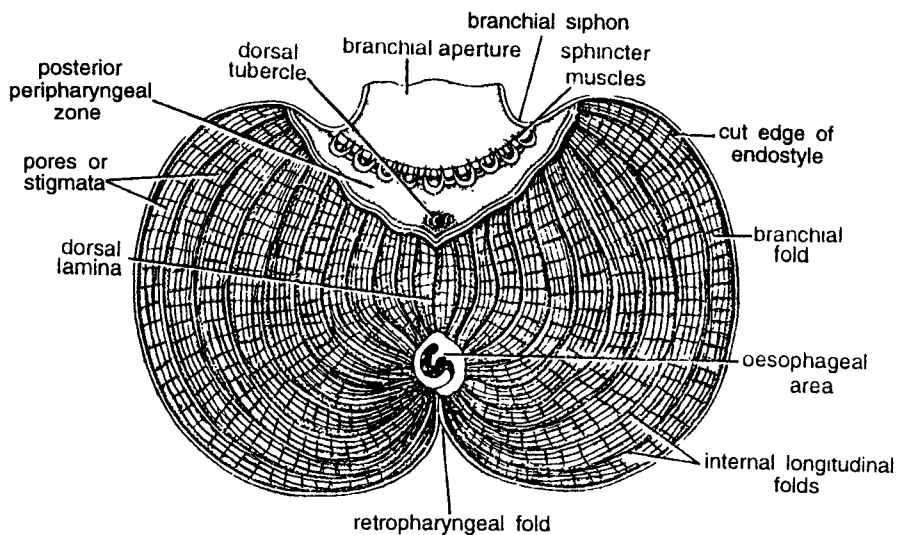

Fig. 7. *Herdmania* : Pharyngeal wall.

- (2) Internally the wall is raised into 9-10 broad, internal **longitudinal folds**, which originate from **posterior peripharyngeal** zone up to outer margin of **oesophagus**.
- (3) The pharyngeal wall is richly vascularised and comprising of internal longitudinal and external transverse vessels. The number of stigmata is about 400,000. Other structures in the mount are branchial siphon, cut edge of endostyle, and retropharyngeal fold.

## B. FISHES

### 8. *Scoliodon* : Ampullae of Lorenzini

Remove a piece of skin around the snout and take out some tissue by forceps and examine it under microscope for above ampullae. Stain in borax carmine, dehydrate, clear and mount.

#### Comments :

- (1) Ampullae of Lorenzini are sensory and mucus-secreting structures.
- (2) Each ampulla is composed of a tube and 8-9 **ampullary chambers** consisting of receptor and mucus-secreting gland cells.
- (3) Receptor cells are innervated by 7th cranial nerve. The tube has external opening.

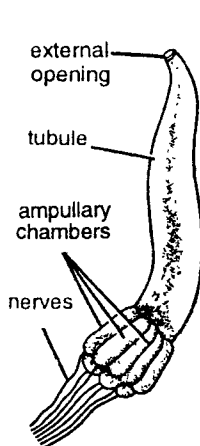

Fig. 8. *Scoliodon* : Ampulla of Lorenzini.

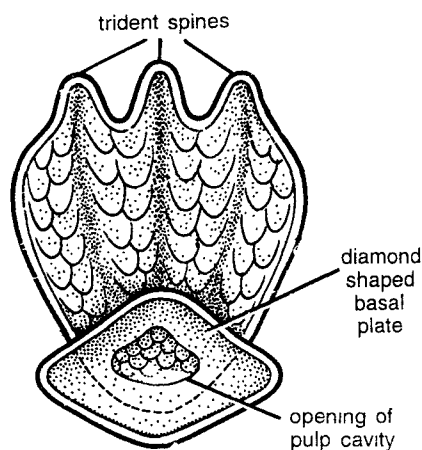

Fig. 9. *Scoliodon* : Placoid scale.

### 9. *Scoliodon* : Placoid Scales

Take a few small pieces of the skin of *Scoliodon* and boil in 5 to 10% KOH solution in test tube till skin dissolves. Cool and allow the scales to settle at bottom. Decant KOH and wash the material in water several times to remove KOH. Stain in borax carmine or picro-indigo carmine, dehydrate, clear and mount. Placoid scales do not take stains properly. These scales can be mounted without staining. Dehydrate, clear and mount.

#### Comments :

- (1) Placoid scales or odontoids are minute dermal denticles, closely arranged in regular oblique rows.
- (2) They form entire exoskeleton of the shark and give a rough appearance to the skin.



- (3) Each placoid scale comprises of a **diamond-shaped, basal plate** embedded in the skin and is derived from dermis.
- (4) Anteriorly the scale has a flat **trident spine** projecting out of the skin.

### 10. *Labeo* (Rohu) : Cycloid Scales

Take one or two scales. Stain in picro-indigo carmine, dehydrate and mount in balsam. Each scale consists of lines of growth and nucleus.

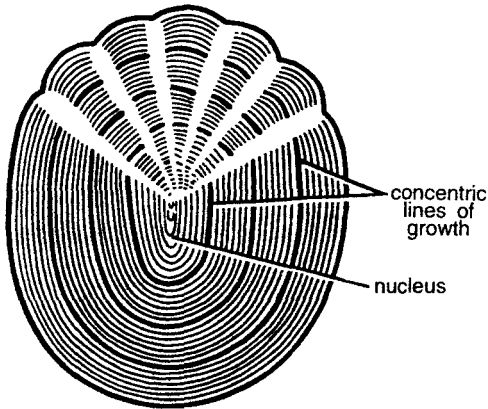

Fig. 10. *Labeo* : Cycloid scale.

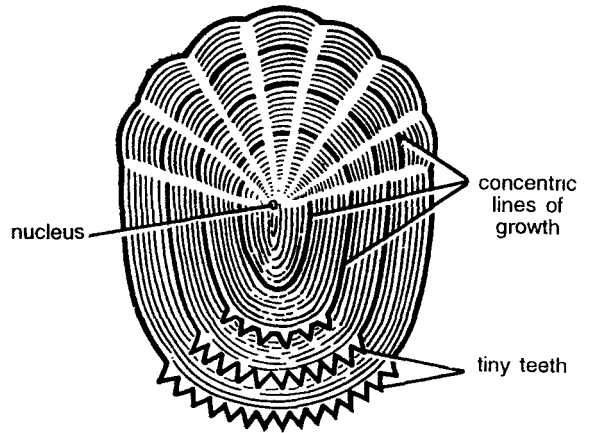

Fig. 11. *Nandus* : Ctenoid scale.

### 11. *Nandus* : Ctenoid Scales

Make permanent mount like cycloid scale. Each scale comprises of several concentric lines of growth, teeth or denticles and nucleus. Ctenoid scales are found in acanthopterygian fishes.

### 12. *Lepidosteus* : Rhomboid Scales

Take one or two scales from the fish and permanently mount like cycloid scale. Each scale is more or less rectangular in shape, having nucleus and lines of growth.

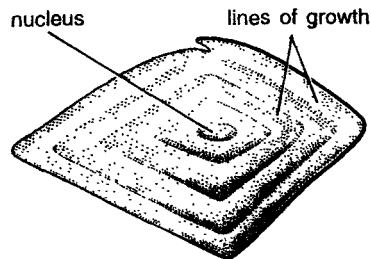

Fig. 12. *Lepidosteus* : Rhomboid scale.

## C. AMPHIBIA

### 13. Frog : Blood

Take blood from a freshly-killed frog at the edge of a slide. Spread the blood over the slide by the edge of another slide in such a way that blood film is formed. Dry the blood film, wash, stain in haematoxylin and eosin, dehydrate, clear and mount.

#### Comments :

- (1) Blood corpuscles of frog are biconvex and nucleated.
- (2) In the slide erythrocytes and leucocytes of different kinds are seen.

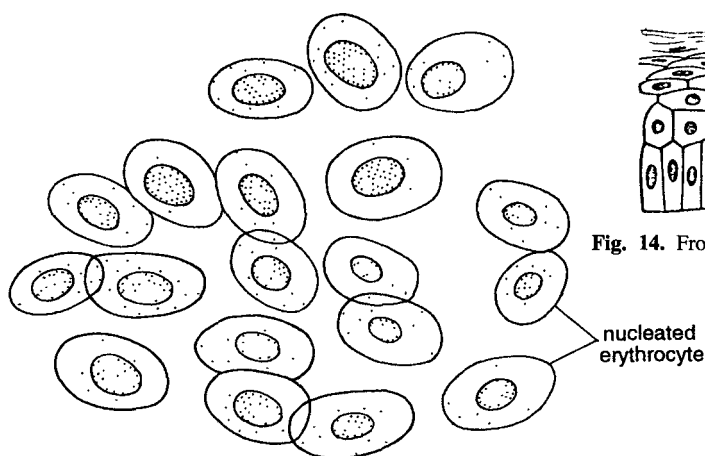

Fig. 13. Frog : Blood.

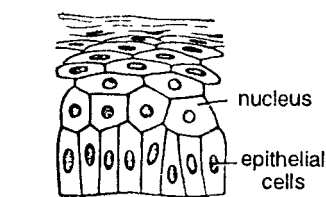

Fig. 14. Frog : Squamous epithelium.

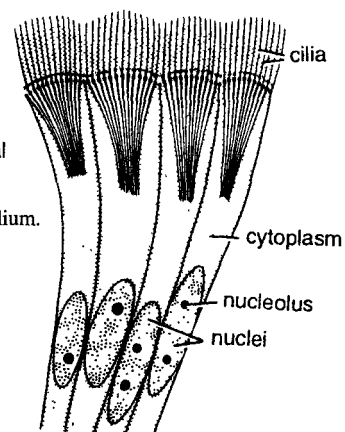

Fig. 15. Frog : Ciliated epithelium.

### 14. Frog : Squamous Epithelium

Catch a frog and keep it in a small trough containing water. The water should be just to submerge the frog. After some time, small flakes of epidermal cells will be seen which are discarded by the frog. Take 10 flakes of epidermal cells, stain in borax carmine, dehydrate, clear and mount.

#### Comments :

Squamous epithelial cells are thin, flat, polygonal and **nucleated**.

### 15. Frog : Ciliated Epithelium

Superficially and gently scrap the roof of the mouth of frog by a scalpel and transfer the scraping over a slide or in a test tube. Wash, stain in borax carmine, dehydrate clear and mount in balsam.

#### Comments :

- (1) The ciliated cells are usually columnar in shape having **nucleus** and **nucleoli**.
- (2) The border of free surface is lined by a bunch of fine tapering vibratile **cilia**, which during life produce a current in the fluid which covers them.

## 16. Frog : Columnar Epithelial Cells

Take a small piece of the intestine from a freshly - killed frog and keep the intestine in a solution of one part of methylated spirit and two parts of water for nearly 24 hours. Cut the intestine longitudinally and scrap the internal epithelial lining by a fine and sharp scalpel. Keep the scraping in a staining tube. Stain in borax carmine, dehydrate, clear and mount in Canada balsam.

### Comments :

The endodermal columnar epithelial cells are tall, **nucleated** and granular.

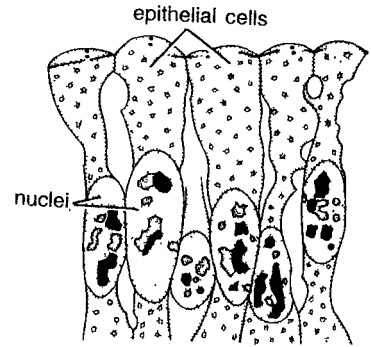

Fig. 16. Frog : Columnar epithelium.

## 17. Frog : Striated or Striped Muscle Fibres

Cut a small portion of thigh muscle of a freshly-killed frog and fix the muscle in corrosive sublimate for 5-10 minutes. Wash the tissue to remove fixative, stain in borax carmine, dehydrate, clear and mount in Canada balsam. Just before mounting tease the individual muscle fibres with fine needles.

### Comments :

The striated muscle cell is covered by a delicate membrane called as sarcolemma and is **multinucleated**. The muscle cell contains **dark** and **light** bands.

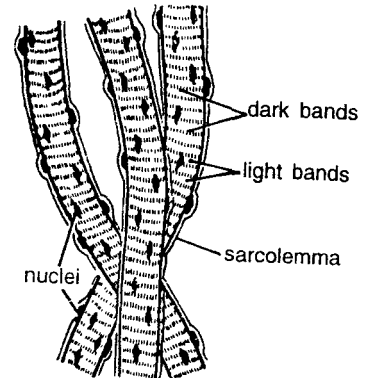

Fig. 17. Frog : Striped muscles.

## 18. Frog : Unstriated or Unstriped Muscle Fibres

Take a few fibres of urinary bladder of a freshly-killed frog, fix in corrosive sublimate, wash the fixative, stain in borax carmine, dehydrate, clear, tease and mount in Canada balsam.

**Comments :** Each fibre is uninucleated and without striations. The cells are spindle shaped covered by **sarcoplasm** and has **myofibrils**.

## 19. Frog : Columella Auris

It is associated with hearing, forming part of middle ear. It is a rod-shaped bone attached with the tympanum. Find the tympanum and cut

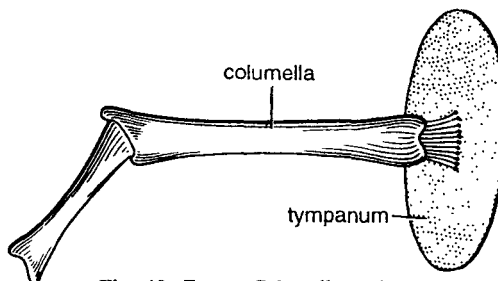

Fig. 19. Frog : Columella auris.

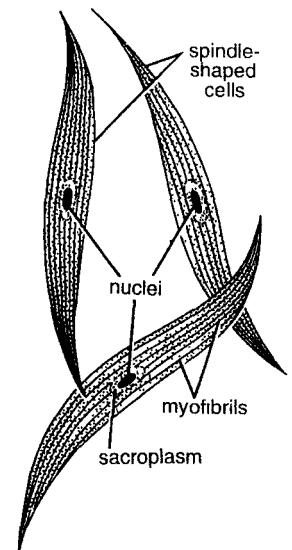

Fig. 18. Frog : Unstriated muscles.

around it. Remove skin and muscles from posterior part of skull. Break prootic bone from dorsal side with scalpel or bone cutter to expose the rod-like columella. Its one end is attached with tympanum and other end with the inner wall of cranium through a small rod. Break the prootic bone till entire columella is exposed. Take out the bone, dehydrate and mount without staining or keep in watchglass in water.

## 20. Frog : T.S. Passing Through a Cranium Cartilage

Passing through a caranium cartilage. Cut thin hand sections of some cartilage like cranium of dogfish (*Scoliodon*) or hyoid apparatus or cartilaginous caps of humerus and femur (frog). Fix the sections in corrosive sublimate for 2 to 3 minutes, wash with water, keep in 30, 50 and 70% alcohols, stain in borax carmine, dehydrate, clear and mount in balsam.

## 21. Nerve Fibre : Medullated and Non-Medullated

### Medullated

Take a small portion of the sciatic nerve of frog in normal saline (0.78% NaCl). Tease it to separate small fibres, fix in corrosive sublimate, wash in water, stain, dehydrate and amount (Fig. 21 A). Medullated nerve fibre consists of medullary sheath, axon fibre, neurilemma and nucleus.

### Non-Medullated

Take a portion of the sympathetic nerve fibre in normal saline, tease, fix in currosive sublimate, wash in water stain, dehydrate and mount in Canada balsam. It may be stained by double stain, *i.e.*, first stain in haematoxylin and then in eosin (see double staining process). Non-medullated nerve fibre consists of axon fibre, neurilemma and nucleus.

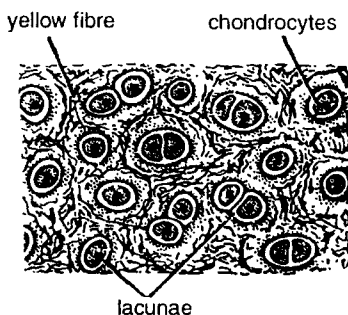

Fig. 20. Frog : Cartilage in section.

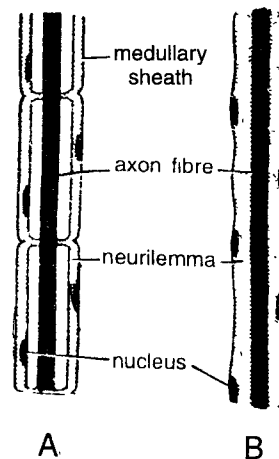

Fig. 21. Nerve fibres : A. Medullated, B. Non-medullated.

## D. BIRDS

### 22. Pigeon : Blood

The method is same as that of frog. The smear contains nucleated erythrocytes oval in shape, monocytes, neutrophils, lymphocytes and platelets.

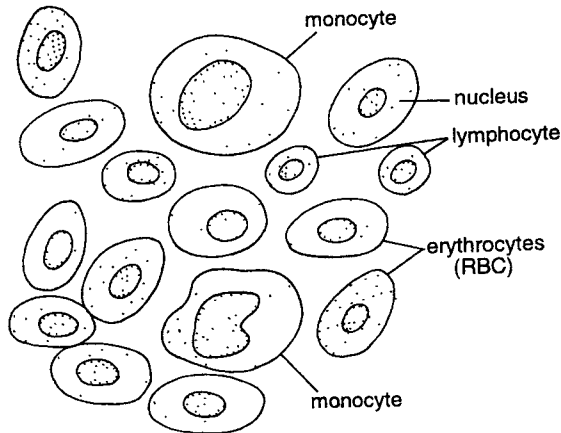

Fig. 22. Pigeon : Blood.

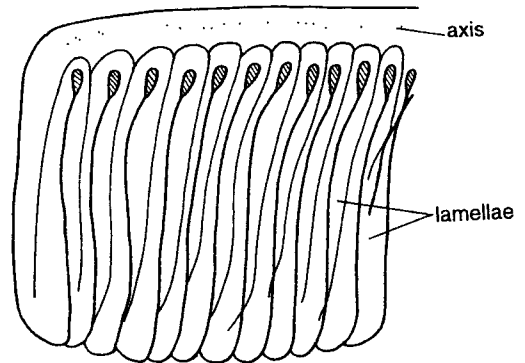

Fig. 23. Pigeon : Pecten.

### 23. Pigeon : Pecten

Dissect the eye to remove the eye ball completely and divide it into two halves. One half will contain pecten at the point of entry of the optic nerve. Take out pecten, a brownish structure by forceps, stain, dehydrate, clear and mount in Canada balsam. Pecten contains axis and vertical lamellae. It probably regulates the fluid pressure within eye.

### 24. Pigeon : V.S. of Eye Showing Position of Pecten

#### Comments :

Various structures seen in the sections are ciliary body, crampton's muscles, iris, conjunctiva, pupil, cornea, aqueous chamber containing aqueous humour, suspensory ligament on ciliary processes, sclerotic ossicles, optic nerve, lens, blind spot, **pecten**, fovea centralis, retina, choroid, sclerotic and vitreous chamber containing vitreous humour.

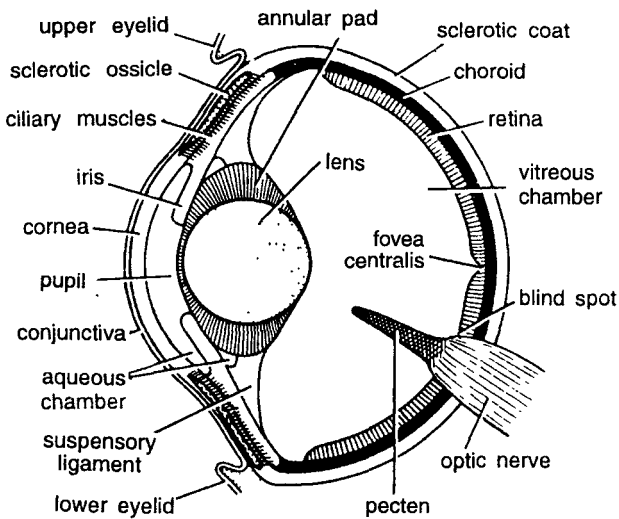

Fig. 24. Pigeon : V.S. of eye showing position of pecten.

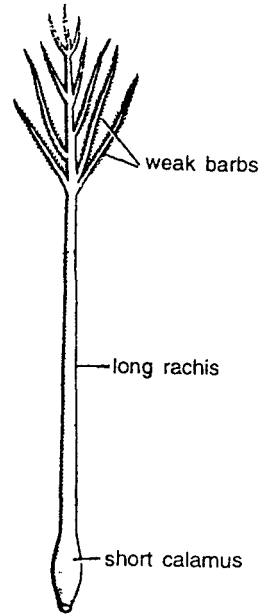

Fig. 25. Filoplume.

## 25. Pigeon : Filoplume

Remove all feathers from pigeon and then small hair-like filoplumes are seen. Pluck some of them, fix, stain, dehydrate and mount in balsam.

**Comments :**

It is composed of a hair-like stem including a short calamus and a long rachis, and a reduced vane including a few weak barbs.

## E. MAMMALS

### 26. Rat : Blood

Procedure is the same as in frog.

**Comments :**

The smear shows non-nucleated erythrocytes or blood corpuscles, monocytes, lymphocytes and polymorphonuclear leucocytes.

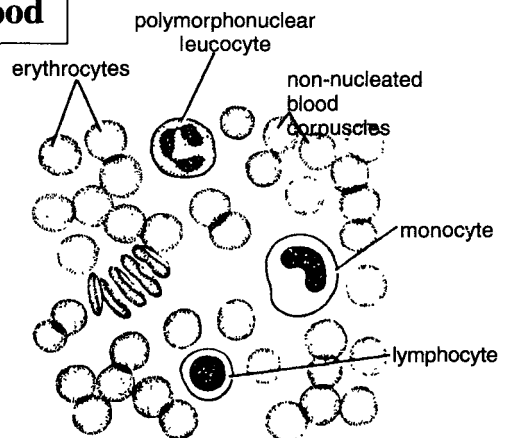

Fig. 26. Rat : Blood.

# 8

## Study of Histological Slides

### Instructions for the Study of Slides

- (1) While studying slides keep in mind the instructions given by the teacher.
- (2) For proper understanding you should know the detailed histological account.
- (3) First observe the slide in low magnification and if structures are not clear, study it under high magnification or even in oil immersion lens.
- (4) Draw the slide on the copy after studying all the details. Keep in mind about the proportion and topography of various parts.
- (5) While writing comments, do write about the special features of the section. For example, in T.S. of the mammalian kidney, cortex and medulla must be clearly shown and structure and function of nephrons must be written.
- (6) Study and label the various parts with the help of the Practical Book.

### A. PROTOCHORDATES

#### 1. *Herdmania* : Metamorphosis : Tadpole Larva

Larva of *Herdmania* is called as **tadpole larva**. After hatching it leads a free-swimming life for 90-180 seconds and then undergoes **retrogressive metamorphosis**.

#### Comments :

##### [I] Tadpole larva

- (1) Larva is minute, transparent and 1.2 mm long. Body divisible into head or trunk and a long posterior tail (Fig. 1-A. Free-swimming larva).

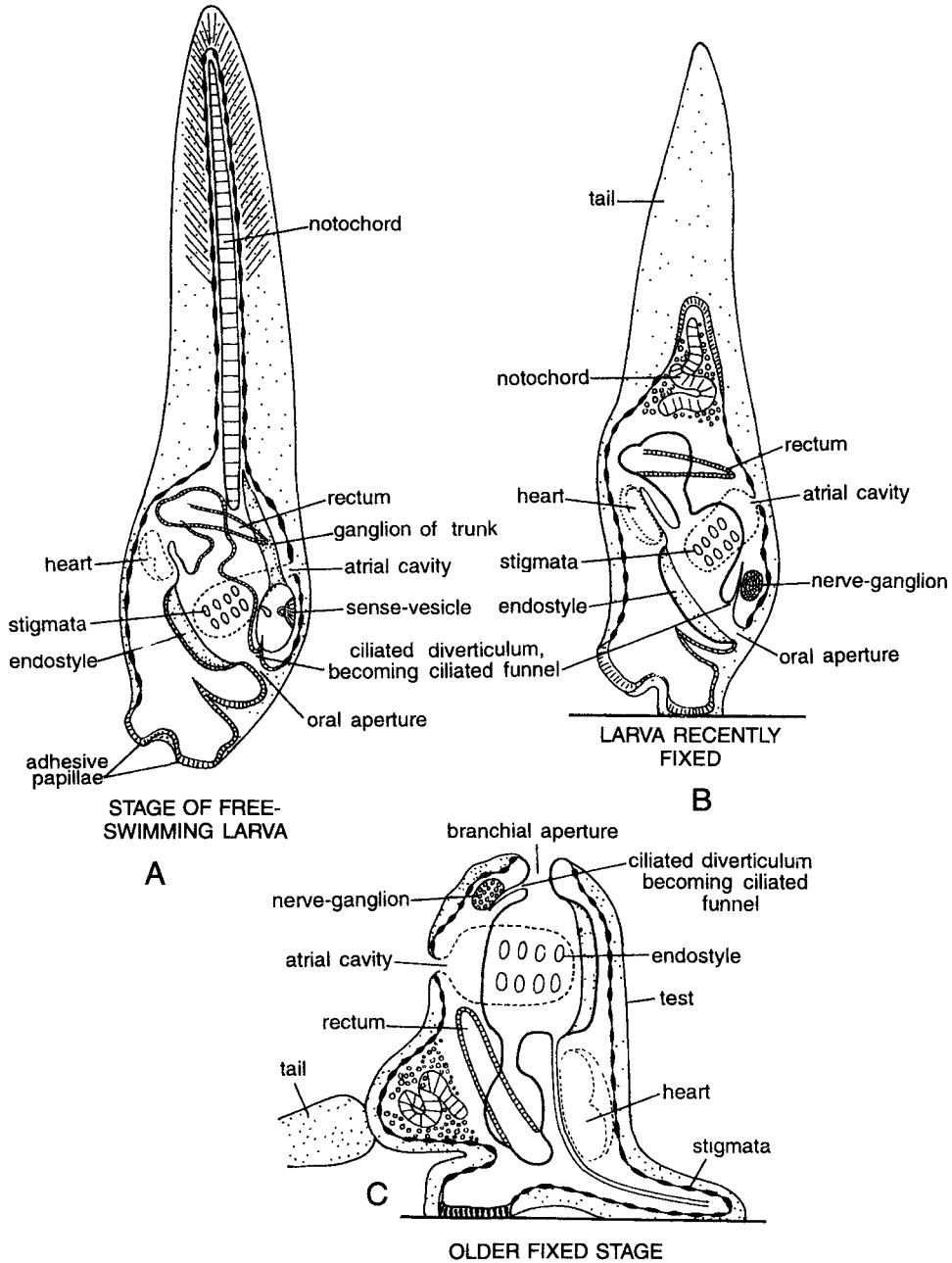

**Fig. 1.** *Herdmania* : Metamorphosis. A. Free-swimming Tadpole larva, B. Recently fixed larva, C. Older fixed larva.

- (2) Anteriorly trunk contains 2 dorsolateral and 1 ventral median adhesive papillae.
- (3) Tail contains tail fin which is extension of thin covering of the body. Along tail fin striations are present giving impression as fin rays. In the axis of tail notochord is present.
- (4) Structures seen adhesive papillae, stigmata, heart rectum, ganglia of trunk, atrium on ciliated funnel.



- (5) Various internal organs comprise sensory vesicle with otolith, visceral ganglion, mouth, pharynx, endostyle, stomach, intestine, atrium and atriopore.
- (6) Tail is a powerful locomotory organ. It has notochord, nerve cord and tail fin.

### [II] Metamorphosis

During metamorphosis, tadpole larva undergoes both retrogressive and progressive changes.

**Retrogressive changes :** The just hatched tadpole larva immediately attaches to substratum by adhesive papillae. It undergoes following degenerative changes (Fig. 1-B. Recently fixed larva).

- (1) Larval tail with tail fin shortens and later on disappears alongwith notochord and nerve cord.
- (2) Anterior region expands. Sense organs and adhesive papillae disappear.
- (3) Other structures seen are rectum, atrium, nerve ganglion, ciliated diverticulum, oral aperture, endostyle, stigmata or gill slits, heart and notochord.

### [III] Progressive changes

Larva undergoes progressive changes. Young adult becomes without tail. Branchial and atrial apertures become functional, pharynx develops gill slits. Young adult undergoes following progressive changes :

- (1) Body becomes surrounded by test or tunic all over. Tail completely degenerates. Branchial and atrial apertures become functional (Fig. 1-C. Older fixed stage).
- (2) Pharynx enlarges and develops **gill slits**. **Stomach, intestine and liver** develop. **Heart, pericardium and gonads** appear. Other structures seen are nerve ganglion, neural duct, endostyle, dorsal tubercle, atrial cavity, stolon, ciliated groove, atrium, and rectum.

**Special features :** All chordate characters are found only in tadpole larva of *Herdmania*. Adults are without any chordate characters. Larva shows unique combination of retrogressive and progressive metamorphosis.

## 2. *Herdmania* : Neural Complex

### Comments :

- (1) Nervous system, excretory system and associated receptor organs are together called as **neural complex**.
- (2) It is composed of **neural gland, nerve ganglion and dorsal tubercle**.
- (3) **Neural gland** is oval-shaped structure, found in the mantle between two siphons and just above the nerve ganglion. Anteriorly, it gives a called an duct of neural gland duct, which opens by a ciliated funnel near the base of dorsal tubercle. It contains central tubule, which gives off a few **branching peripheral tubules**. Neural gland is supposed to be excretory in function. It secretes excretory material appearing as pigmented granules in the substance of the gland. Cells impregnated with such granules are discharged into the branchial sac. Posteriorly neural gland given rise to nerve fibres.
- (4) Dorsal ganglion or **nerve ganglion** is solid, elongated structure, found dorsally between branchial and atrial openings. It constitutes central nervous system. It gives 3 branches to branchial siphon and 2 nerves to atrial siphon. Experimental removal of brain indicates that it is not very much needed for the life and metabolic activities.
- (5) **Dorsal tubercle** has a broad base from which 2 spirally coiled cones originate. Each cone has 3 coils of spirally ciliated channel. It is supposed to be chemosensory.

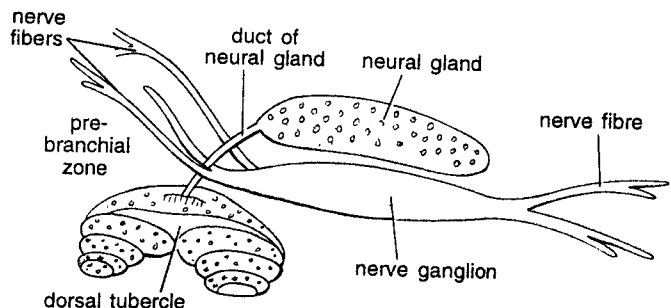

Fig. 2. *Herdmania* : Neural complex.

**Identification :** Since it contains dorsal tubercle and above features, hence it is **neural complex of *Herdmania***.

### 3. *Herdmania* : Various Spicules

**Comments :**

- (1) **Spicules** of *Herdmania* are found embedded in test, body wall and organ systems and are calcareous in nature.
- (2) Spicules are of three kinds.

**[I] Microscleres**

These are embedded in test, are microscopic and measure 40 to 80 microns long. Each spicule has a small knob-like head and an elongated body containing several spiny rings.

**[II] Pipette-shaped**

Found in body wall, particularly in the region of gonads and liver. They are swollen in middle, pointed at tips and measure 3.5 mm in length.

**[III] Spindles shaped**

Usually found associated with blood vessels and part of alimentary canal, measure 1.5 to 2.5 mm in length and contain 15 to 20 rings of minute spines.

**Special features :** Spicules protect the animal from predators. They serve to attach body wall with the test. They also form the framework of certain passages for blood vessels.

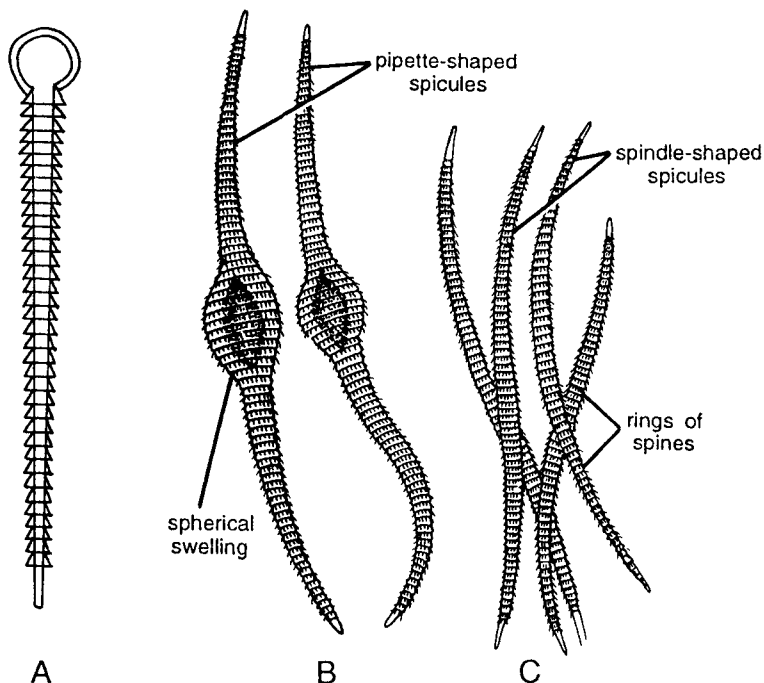

**Fig. 3. *Herdmania* : Spicules. A. Microscleres, B. Pipette shaped, C. Spindle shaped.**

#### 4. *Amphioxus* : V.L.S. Anterior Region

##### Comments :

- (1) The vertical longitudinal section shows **buccal cirri**, **wheel organ**, **velum** and some pharyngeal region.
- (2) In a carmine stained section, prominent dorsal structures are **fin rays**, **notochord** and **nerve cord**.
- (3) Dorsal fin is low, continuous and supported by **fin rays**.
- (4) **Nerve cord** or spinal cord lies just above the notochord. It contains anterior and posterior pigmented spots and anteriorly swollen as cerebral vesicle.
- (5) Notochord lies just above the nerve cord forming axial skeletal rod. It extends antero-posteriorly.
- (6) Anterior end projects as the **rostrum**. Important ventral structures are **oral hood**, **vestibule**, **wheel organ**, **pharynx** and **atrium**.
- (7) **Oral hood** is clearly seen with **oral cirri**, which help during feeding by turning inwards to prevent sand particles from passing into buccal cavity. Oral hood guards the vestibule or buccal cavity. At the hinder wall of vestibule lies a vertical partition called **velum** with velar tentacles.
- (8) In front of velum is a peculiar **wheel organ** which helps in driving a current of water loaded with food particles into the mouth.

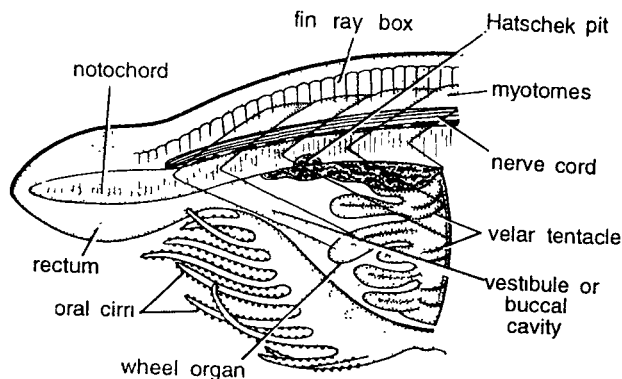

Fig. 4. *Amphioxus* : V.L.S. anterior region.

**Identification :** Since the above section has oral cirri and all above features, hence it is *Amphioxus* V.L.S. region.

#### 5. *Amphioxus* : T.S. Passing Through Oral Hood

##### Comments :

**A. Under low magnification :** (10 X eye-piece; 4 X objective).

- (1) At the anterior end of *Amphioxus* is a mid-ventral opening encircled by frilled membrane, called oral hood. The T.S. Passing through the oral hood shows body wall, dorsal fin ray, nerve cord, notochord, vestibule and oral hood, etc.
- (2) Body wall is composed of **epidermis**, **dermis** or **cutis** and **muscle layer**.
- (3) **Epidermis** is covered by a non-pigmented and **iridescent cuticle**. Unlike other chordates, the *Amphioxus* epidermis is very thin. **Dermis** is indistinct.
- (4) Below epidermis and dermis is a thick longitudinal muscle layer. The cut segmental blocks or **myotomes** are very distinct, separated by **myosepta**. The muscle fibers in anterior half section are directed upwards while in posterior half, backwards. Below muscle layer is coelom.
- (5) Dorsally below the epidermis is a **dorsal fin ray**.
- (6) Dorsal tubulated glandular **nerve cord** having a central canal or neurocoel and below it notochord are clearly seen. The notochord is composed of chordal or fibrous sheath, which encloses vacuolated notochordal cells filled with homogeneous liquid.

(7) Ventrally, section shows a large stomodaeum, oral hood and cut part of buccal cirri in a circular manner. Oral hood contains lymph spaces.

(8) Dorsal wall of buccal cavity has a sensory **Hatscheck's groove**.

**B. Under high magnification :** (10 X eye-piece; 40 X objective).

(1) **Epidermis** is very clearly seen under this magnification. It is composed of single layered **rounded epithelial cells** with some chemoreceptor cells and unicellular gland cells covered by thin **cuticle**.

(2) The **myosepta** are continuous with epidermis and visceral layer. Myotome muscles and myoseptum are seen.

**Identification :** Since the section has **buccal cirri** and all above features, hence it is T.S. passing through **oral hood of Amphioxus**.

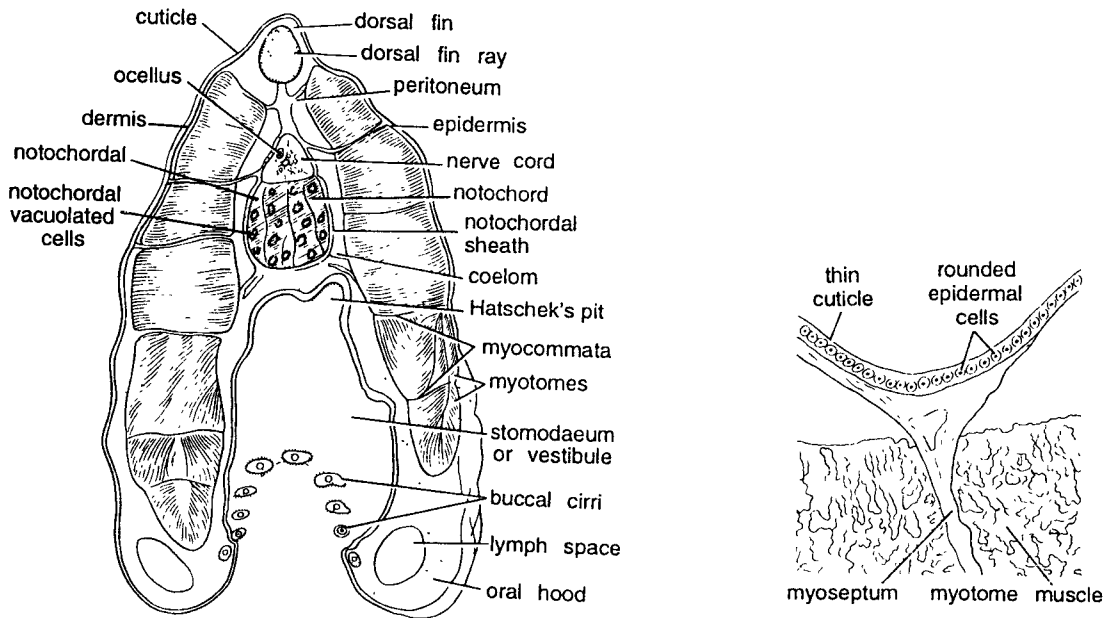

Fig. 5. *Amphioxus* : A. T. S. passing through oral hood (under low magnification), B. Epidermis under high magnification.

## 6. *Amphioxus* : T.S. Passing Through Pharynx

### Comments :

(1) Pharynx is a large elongated, sac-like respiratory and digestive organ, extending from behind velum upto the intestine. T.S. passing through **anterior pharynx** shows **body wall layers, dorsal fin ray, nerve cord, notochord, large cut pharynx with endostyle and metapleural folds**.

(2) Body wall is composed of **cuticle, epidermis, dermis and muscle layer**.

(3) **Cuticle** and epidermis are thin-layered and indistinguishable. Below epidermis the dermis is also thin-layered.

(4) More than three-fourth of the section from dorsal side contains thick; cut, segmental muscle bundles or **myotomes** separated by transverse **myosepta**. The first three myotomes have side muscle fibres while in posterior, half the muscle fibers are backwardly directed.

(5) Dorsally, just beneath epidermis, is the **dorsal fin ray**.

(6) Below dorsal fin ray is **nerve cord** and beneath **nerve cord** is **notochord**. Notochord is surrounded by notochordal sheath and filled with vacuolated notochordal cells.

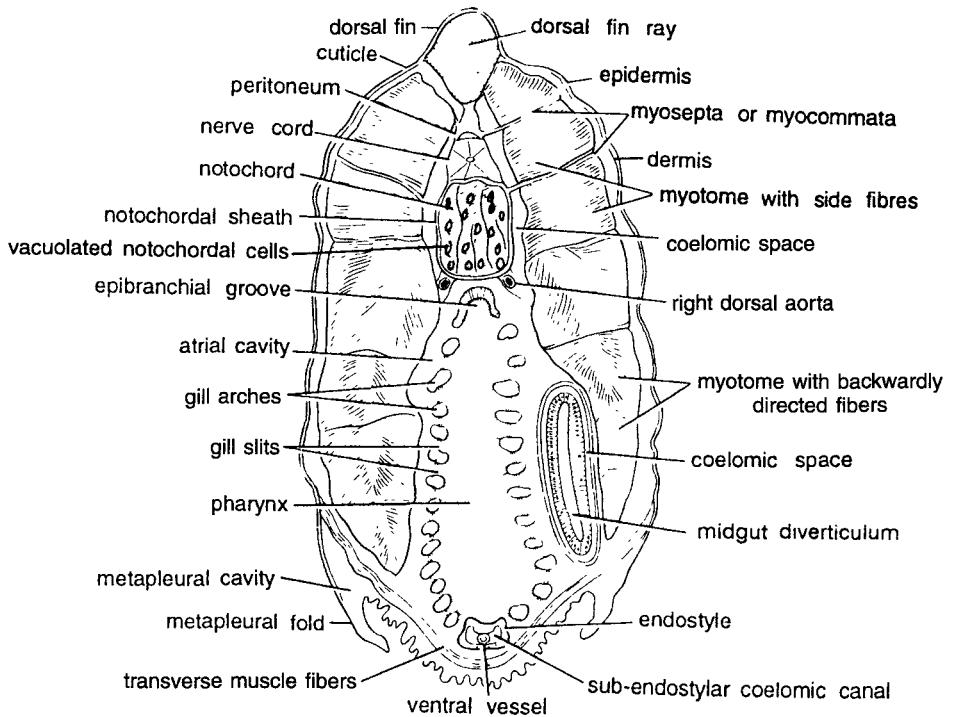

Fig. 6. *Amphioxus* : T. S. passing through pharynx under low magnification.

- (7) Ventral half of the section contains the large pharynx surrounded by **atrial cavity** and perforated by **gill slits**. It contains longitudinal rows of cilia in the form of an **epipharyngeal groove** mid-dorsally and an **endostyle** enclosing an **endostylar canal**, midventrally. The **ciliated grooves** direct food material towards **oesophagus**. The sides of the pharyngeal cavity contain several **gill arches**. **Pharynx** is adapted for ciliary feeding.
- (8) Two **metapleural folds** with **metapleural cavity** are seen posteriorly.
- (9) In some sections through **pharynx**, midgut diverticulum or liver is also seen. Other structures seen are **dorsal aorta**, coelomic spaces, gill arches, ventral vessel and transverse muscle fibers.

**Identification** : Since this section shows epipharyngeal groove, gill slits and all above features, hence it is T.S. *Amphioxus* through **pharynx**.

## 7. *Amphioxus* : T.S. Passing Through Ovaries

### Comments :

**Under low magnification** : (10 X eye-piece; 4 X objective).

- (1) T.S. passing through above region shows **body-wall layers**, **nerve cord**, **notochord**, **pharynx**, **midgut** (liver) and **ovaries**.
- (2) Body wall is composed of **cuticle**, **epidermis**, **dermis** and **muscle layer**. Cuticle, epidermis and dermis are very thin and indistinguishable. The musculature consisting of longitudinal fibers is well developed. First four segmental **myotomes** are thick and separated by **myosepta**. Last two myotomes are comparatively thinner. **Muscle fibres** in first three myotomes are directed sideways and upwards while muscle fibres in last three myotomes are **backwardly directed**.

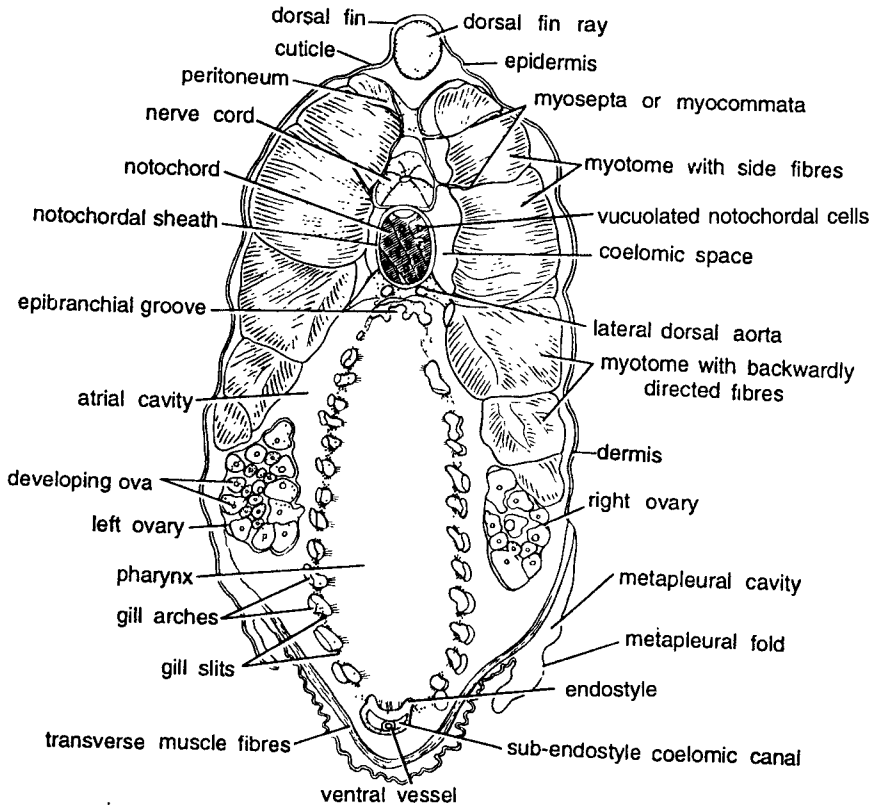

Fig. 7. *Amphioxus* : Female T. S. passing through ovaries.

- (3) Dorsal **fin ray** is present just beneath the mid-dorsal **epidermis**.
- (4) Below fin ray is nerve cord containing **neurocoel**. Notochord below **nerve cord** with chordal **sheath** enclosing vacuolated notochordal cells filled with homogeneous fluid.
- (5) Ventral part of section contains two **ovaries**.
- (6) Ovaries, enclosed in coelomic sac, contain **several ova** and are found from 25-51 segments.
- (7) Pharynx, surrounded by **atrial cavity**, contains gill slits, **epipharyngeal groove** dorsally and **endostyle** ventrally. Two **metapleural folds** are seen ventro-laterally.
- (8) In some sections midgut **diverticulum** or liver is also seen.

Other structures seen are **ventral vessel** sub-endostyle coelomic caudal and coelomic space.

**Identification** : Since the section contains ova and all above characters, hence it is T.S. of female through ovaries of *Amphioxus*.

## 8. *Amphioxus* : T.S. Passing Through Testes

### Comments :

- (1) T.S. passing through testes shows **body wall layers**, **nerve cord**, **notochord**, large **pharynx**, etc.
- (2) Body wall is composed of thin **cuticle**, **thin epidermis** and **dermis** and thick cut longitudinal segmental **myotomes** separated by **myosepta**. First four myotomes are quite thick and last two comparatively thinner. Muscle fibres in first three myotomes are slightly **upwardly directed** while in posterior three **backwardly directed**.
- (3) **Dorsal fin ray** just below **epidermis**.

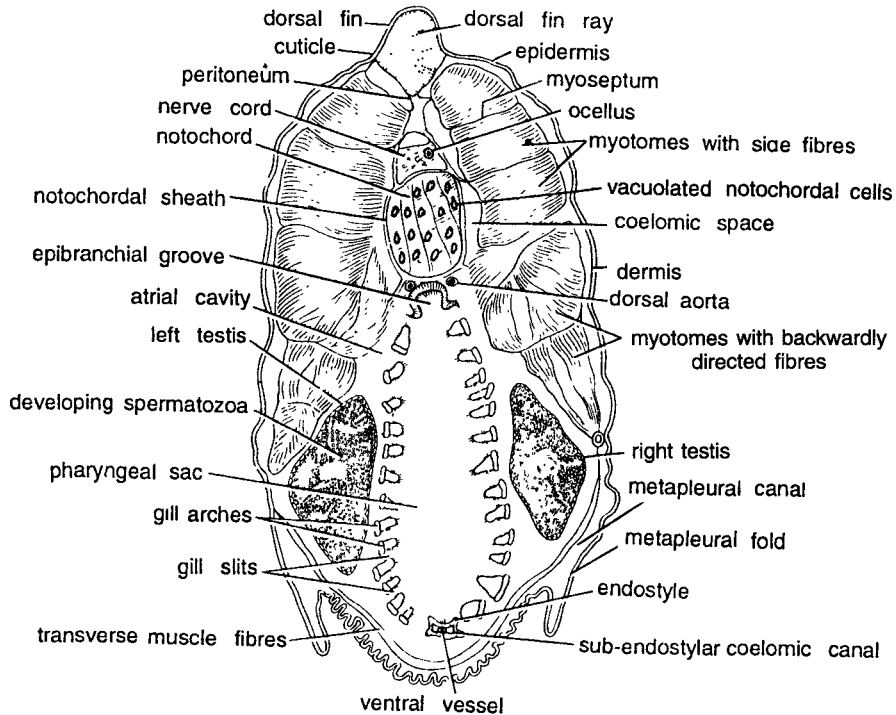

Fig. 8. *Amphioxus* : Male T. S. passing through testes.

- (4) **Nerve cord** containing **neurocoel** is present below the fin ray.
- (5) Below the **nerve cord** is present notochord composed of chordal sheath enclosing vacuolated notochordal cells filled with homogeneous fluid.
- (6) **Pharynx** is a large cavity and contains dorsal **epipharyngeal groove**, **ventral endostyle** and on sides several gill clefts and gill arches.
- (7) **Testes** are found on both sides having several dot-shaped cut spermatozoa.
- (8) **Metapleural folds** and **metapleural canals** are seen ventro laterally.

Other structures seen are **gill arches**, **peritoneum**, **transverse muscle fibres**, **sub-endostylar coelomic canal**, **coelomic spaces**, **dorsal aorta**, **septum** and **ocellus**.

**Identification** : Since the section contains dot-shaped cut spermatozoa, and all above characters, hence it is T.S. of male through **testes of *Amphioxus***.

## 9. *Amphioxus* : T. S. Passing Through Mid-gut or Intestine

### Comments :

- (1) Intestine is found in posterior region. T.S. through intestine shows usual **body wall**, **layers**, **nerve cord**, **notochord**, **intestine** and **metapleural folds**.
- (2) Body wall is composed of thin **cuticle**, **thin epidermis**, **dermis** and **muscle layer**.
- (3) **Muscle layer** consists of alternating thick segmental myotomes separated by **myocommata**. Four myotomes forming anterior end are very thick while posterior last three **myotomes** are thinner. Muscle fibres in first three myotomes are **directed slightly upwards** while last three have **backwardly directed** muscle fibres.

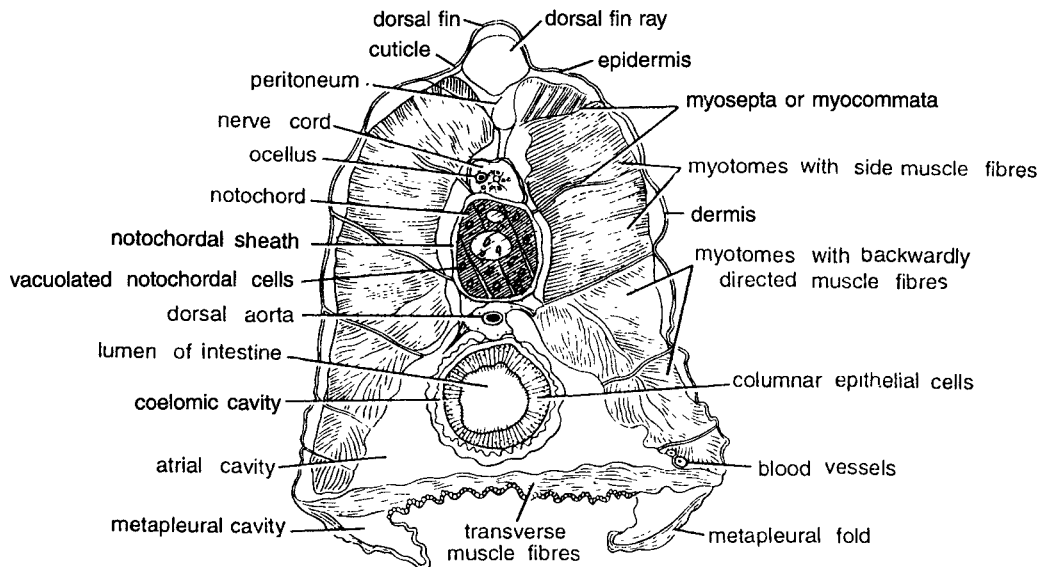

Fig. 9. *Amphioxus* : T. S. passing through mid intestine.

- (4) **Dorsal fin ray** is found below epidermis.
- (5) Glandular **nerve cord** is found below **dorsal fin ray**. It encloses central canal or **neurocoel**.
- (6) **Notochord** found below nerve cord is with vacuolated chordal cells. There is a single **dorsal aorta** below **notochord**.
- (7) Ventral half of the section contains **mid-gut**, **coelomic cavity** and **atrial cavity**. Below coelom is well developed **atrial cavity**. Below atrial cavity transverse muscles and metapleural folds are seen.
- (8) **Mid-gut** or **intestine** is found in the centre, composed of large **endodermal columnar ciliated epithelial cells**.
- (9) Other structures seen in the section one **ocellus**, **peritoneum**, **metapleural cavity**, transverse muscle fibres, metapleural folds, blood vessels.

**Identification** : Since the section contains cut intestine, renal papillae and all above characters, hence it is T.S. of *Amphioxus* through **intestine**.

## 10. *Amphioxus* : T.S. Passing Through Atriopore

### Comments :

- (1) Animal narrows towards the posterior region. Hence T.S. passing through atriopore shows smaller section. In the section **body wall layers**, **nerve cord**, **notochord**, and **atriopore** are seen (Fig. 10).
- (2) Body wall comprises of thin **cuticle**, single-layered thin **epidermis**, thin **dermis** and segmental muscles or **myotomes** which are comparatively thinner and separated by **myocommata**.
- (3) **Dorsal fin ray** is present below the epidermis.
- (4) **Nerve cord** is found below 2 or 3 myotomes in the middle. It contains neurocoel.
- (5) **Notochord** with notochordal sheath and vacuolated chordal cells is present below the nerve cord. Just below notochord is single dorsal aorta.
- (6) **Intestine** shows smaller diameter and is composed of endodermal cells. It is surrounded by coelomic and atrial cavities. Few cut portal veins are also seen.



- (7) **Atrial cavity** surrounds coelom and opens ventrally by a distinct **atriopore**, situated in front of the ventral fin.
- (8) The two **metapleural folds** are distinctly seen.

**Identification :** Since this section contains atriopore and all above characters, hence it is T.S. of *Amphioxus* through **atriopore**.

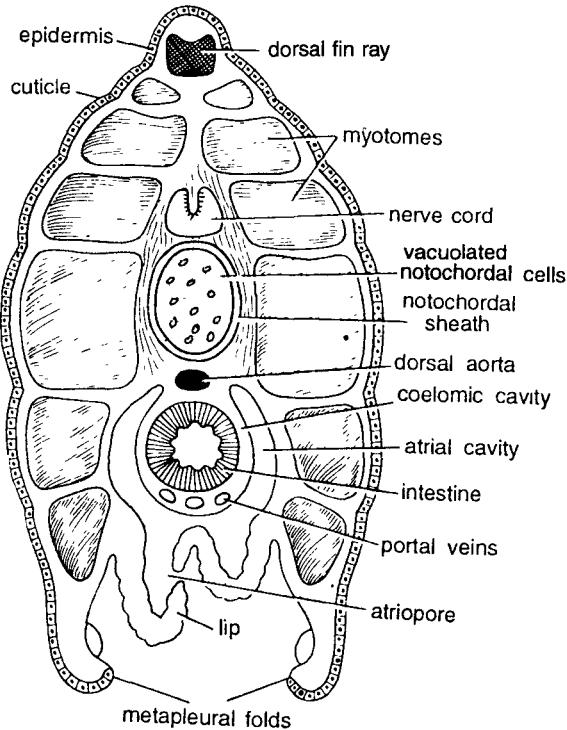

Fig. 10. *Amphioxus* : T.S. passing through atriopore.

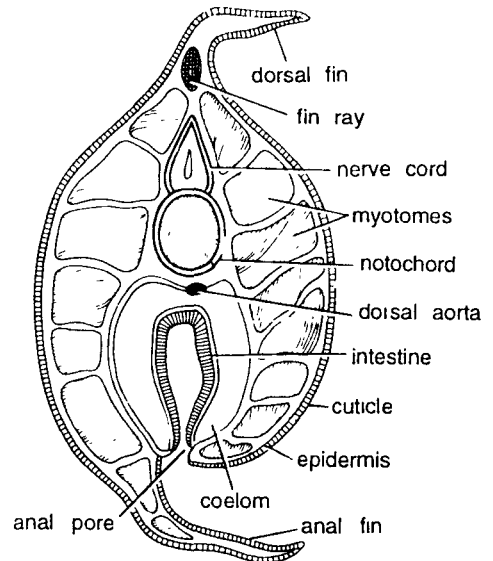

Fig. 11. *Amphioxus* : T.S. passing through anal region.

## 11. *Amphioxus* : T.S. Passing Through Anal Region

### Comments :

- (1) As the body narrows posteriorly the T.S. passing through anal region shows smaller diameter and it tapers at both the ends.
- (2) Body wall is composed of thin **cuticle**, **epidermis**, **dermis** and **myotomes** alternating with **myosepta**.
- (3) Dorsal fin ray is present below the pointed epidermis dorsally.
- (4) **Nerve cord** is found below dorsal fin ray and first myotome. It has central canal.
- (5) **Notochord** is found beneath the nerve cord. It has vacuolated chordal cells. Dorsal aorta is present beneath the notochord.
- (6) Coelomic cavity enclosing intestine.
- (7) Intestine opens to the exterior by the **anus**.
- (8) Ventral fin is pointed in section.

**Identification :** Since the section contains anus and all above characters, hence it is T.S. of *Amphioxus* through **anal region**.

## 12. *Amphioxus* : T.S. Passing Through Caudal Region

### Comments :

- (1) Section through caudal region is somewhat smaller in size and without any opening.
- (2) **Body wall** is composed of thin **cuticle**, **single-layered epidermis**, **dermis** and **myotomes** alternating with **myocommata**. Three upper **myotomes** have side muscle fibres while 2 posterior ones have backwardly directed fibers. Myotomes are separated by myosepta.
- (3) **Dorsal fin ray** found at the base of dorsal fin below epidermis.
- (4) **Nerve cord** with neurocoel lies below **dorsal fin ray**.
- (5) **Notochord** with vacuolated chordal cells is found below the nerve cord.
- (6) **Caudal artery** and **vein** appear below notochord.
- (7) Alimentary canal, atrial cavity, coelom and metapleural folds are absent in this section.
- (8) Caudal fin with **fin ray** is present posteriorly.

**Identification :** Since there is no opening, it is T.S. passing through the **caudal region of *Amphioxus***.

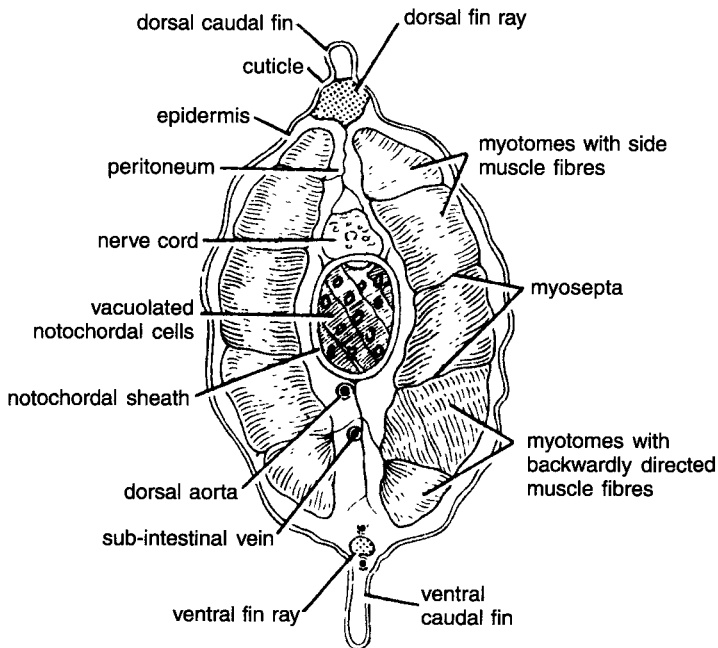

**Fig. 12.** *Amphioxus* : T. S. passing through caudal region.

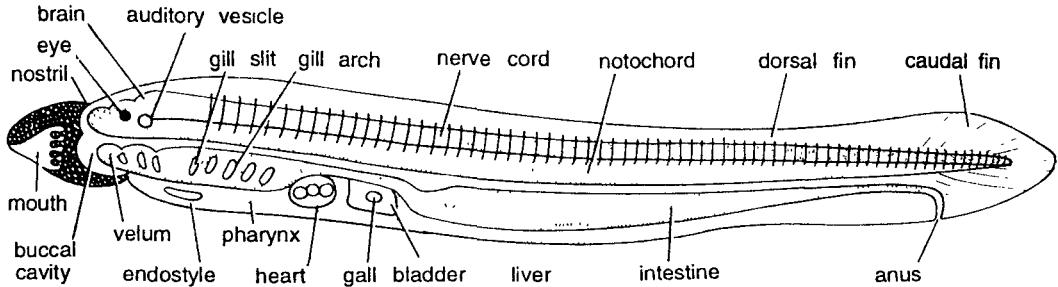

Fig. 13. Ammocoete larva of Lamprey.

## B. CYCLOSTOMATA

### 13. Lamprey : Ammocoete Larva : Whole Mount

#### Comments :

- (1) It is one of the stages in the development of lamprey. Egg develops into **ammocoete larva**, which is a tiny transparent creature in the beginning and later on becomes opaque and 170 mm long. It lies buried in mud.
- (2) General body form is **eel-like**. Body divisible into **head, trunk and tail**.
- (3) Mouth or buccal cavity is surrounded by upper and lower lips, having a number of buccal tentacles or **oral cirri**.
- (4) **Velum** is found at the posterior end of the buccal cavity followed by the pharynx.
- (5) **Pharynx** has **7 pairs of gill-slits**. **Gill arches** and gill lamellae lie in the wall of these pouches. Ventrally pharynx contains double strand of mucus-secreting cells called as **endostyle** which forms thyroid gland of the adult.
- (6) **Head** contains median **nostril**, **eyes** on sides and an **auditory organ** and brain.
- (7) Larva contains median fin which forms continuous dorsal, caudal and ventral fins.
- (8) **Nerve cord** with anterior brain divisions extends antero-posteriorly along the **notochord**. **Notochord** extends along the entire length of the body. **Myotomes** are segmentally arranged. Heart lies ventrally posterior to the **pharynx** and has 3 chambers.
- (9) Digestive system after **pharynx** consists of **oesophagus**, wider **intestine**, anal opening, **liver** and **gall bladder**.
- (10) Ammocoete larva shows **intermediary characters** between Cephalochordata and Cyclostomata.

**Identification :** Since the above larva contains seven pairs of gill-slits and all above characters, hence it is **Ammocoete larva**.

### 14. Lamprey : Ammocoete Larva : T.S. Passing Through Branchial Region

#### Comments :

- (1) T.S. passing through branchial region shows distinct gill lamellae along with nerve cord and notochord, etc.
- (2) Body wall is composed of **epidermis, dermis** and **muscle layer**. The muscles comprise of thick myotomes, separated by **myocommata**.

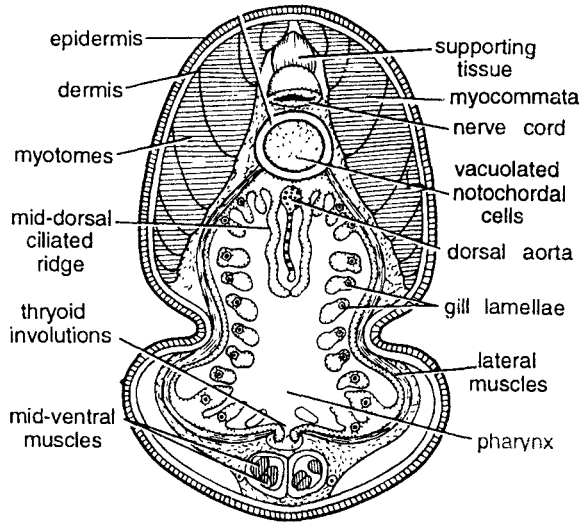

Fig. 14. Ammocoete larva : T. S. passing through branchial region.

- (3) **Nerve cord** lies just between **supporting tissue** and **notochord**.
- (4) **Notochord** is surrounded by the **notochordal sheath** and has vacuolated chordal cells. Below notochord is wide-lumened **pharynx**. It contains several **gill lamellae** supported by lateral muscles.
- (5) On dorsal side of the **pharynx** is **dorsal aorta** and **mid-dorsal ciliated ridge**, while on ventral side is **thyroid** involution.
- (6) Below **thyroid involution** bundles of **mid-ventral muscles** are seen.
- (7) Pharynx also contains **velum**, ciliated bands and **endostyle**. **Pharynx** performs both nutritive and respiratory functions.
- (8) Endostyle in larval condition secretes mucus but during metamorphosis it develops into thyroid gland, which contains iodine vesicles.

**Identification :** Since the larva contains mid-dorsal ciliated ridge and all above characters, hence it is T.S. of **Ammocoete larva** passing through **branchial region**.

## 15. Lamprey : Ammocoete Larva : T.S. Passing Through Intestine

### Comments :

- (1) T.S. passing through the intestine shows usual parts of the **body wall, nerve cord, notochord, muscles and intestine**.
- (2) **Body wall** is composed of **epidermis, dermis and myotomes**, which are especially developed on dorsal side.
- (3) Supporting tissue and **nerve cord** lie close together.
- (4) **Vacuolated notochord** is surrounded by notochordal sheath.
- (5) Intestine is ventrally situated. It is lined by endodermal columnar cells.
- (6) On ventral side intestinal epithelium is raised to form **typhlosole**, which increases absorptive surface.
- (7) Sub-vertebral blood sinus is found below the notochord.
- (8) **Intestine** is surrounded by coelomic cavity lined by coelomic epithelium.

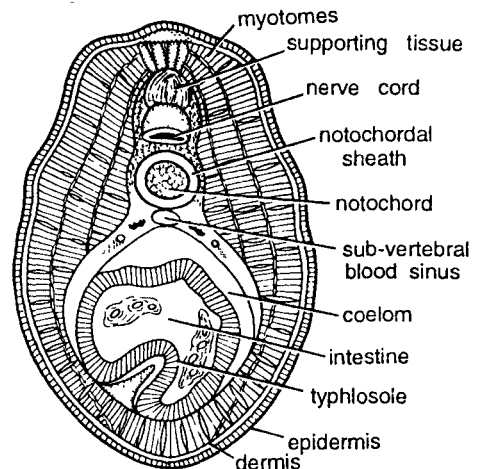

Fig. 15. Ammocoete larva : T.S. passing through intestine.

**Identification :** Since this section has typhlosole in intestine and all above characters, hence it is T.S. of *Ammocoete* larva passing through **intestine**.

## 16. *Petromyzon* : T.S. Passing Through Branchial Region

### Comments :

- (1) T.S. passing through branchial region shows **body-wall layers**, **prominent gill lamellae** along with muscles, nerve cord, notochord and other **visceral** structures.

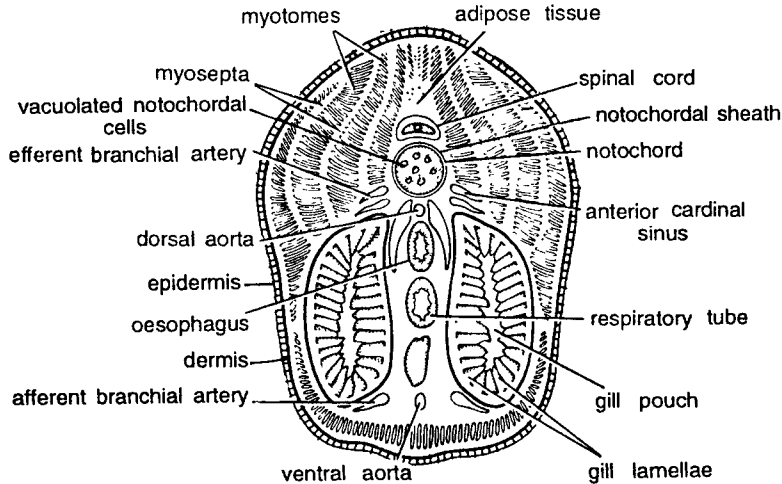

**Fig. 16.** *Petromyzon* : T.S. passing through branchial region.

- (2) Body wall is composed of epidermis made up of stratified squamous epithelium, which is sometimes covered with polyhedral cells, dermis and muscle layer. Epidermal cells may be mucus-secreting cells, granular cells and club-shaped cells.
- (3) **Dermis** is made up of a dense connective tissue of compact fibres.
- (4) Muscle layer comprises of thick **myotome** bundles and **myosepta** or **myocommata**.
- (5) Cut **notochord** is composed of **vacuolated notochordal cells** covered by **notochordal sheath**.
- (6) Above notochord is **nerve cord** and **adipose tissue**, which forms fat column.
- (7) Dorsal aorta is found below notochord followed dorsoventrally by **oesophagus**, **respiratory tube** and **ventral aorta**.
- (8) **Anterior cardinal sinus** and **efferent branchial artery** are found on the sides of dorsal aorta in tandem position.
- (9) **Afferent branchial artery** is found on each side of the **ventral aorta**.
- (10) Two gills consisting of gill lamellae enclosing **gill pouch** occupy large space in the ventral half of the section.

**Identification :** Since this section contains large pharynx with gill pouches and all above structures, hence it is T.S. of *Petromyzon* passing through **branchial region**.

## 17. *Petromyzon* : T.S. Passing Through Trunk Region

### Comments :

- (1) This section can be at once recognized by the presence of various visceral organs, containing **body-wall** layers, **nerve cord**, **notochord**, **kidney**, **gonads** and **intestine**, etc.
- (2) Body wall comprises of polyhedral cells, stratified squamous **epithelium**, **dermis** and muscle layer. Epidermal cells consist of mucus secreting cells, granular cells and club-shaped cells.
- (3) **Dermis** is made of dense connective tissue of compact fibres.
- (4) **Myotomes** separated by **myocommata** are very distinct.
- (5) **Anterior dorsal fin** is supported by cartilaginous radials arranged in a single series. Some **fin muscles** are also seen in the section.
- (6) **Vacuolated notochord** is composed by notochordal tissue covered by notochordal sheath, which with its basement membrane forms elastic interna and a thin black elastic externa. **Nerve cord** is found above notochord.
- (7) Also note posterior **cardinal veins**, **dorsal aorta** below notochord, and two **kidneys** with mesonephric duct.
- (8) **Gonad** (ovary) is suspended from dorsal body wall by mesovarium. The intestine with spiral valve is also seen below ovary. **Coelom** is present.

**Identification :** Since this section contains visceral organs and all above features, hence it is T.S. of *Petromyzon* passing through trunk.

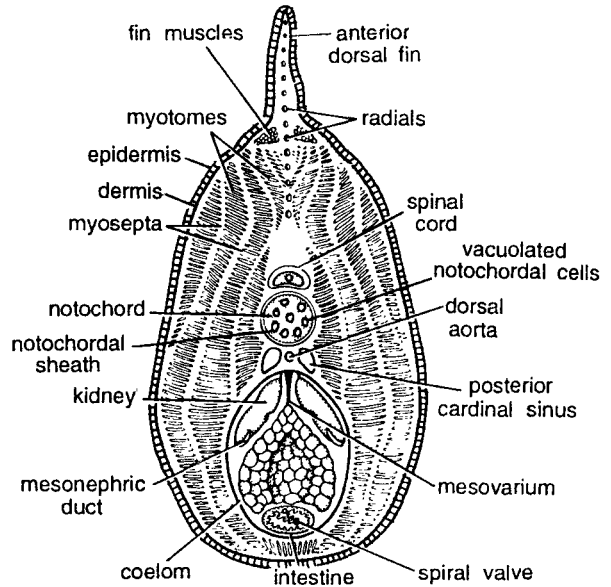

Fig. 17. *Petromyzon* : T.S. passing through trunk region.

## 18. *Petromyzon* : T.S. Passing Through Tail Region

### Comments :

- (1) Section is smaller in outline.
- (2) Body wall is composed of **epidermis**, **dermis** and **muscles**. (For details of body wall layers, see T.S. *Petromyzon* passing through branchial region).
- (3) **Dorsal** and **ventral lobes** of the caudal fin are supported by cartilaginous radials.
- (4) **Spinal cord**, **notochord**, **caudal artery**, and **caudal vein** are seen in the middle of the section.
- (5) **Myotomes** and **myosepta** are distinct.

**Identification :** Since the section contains caudal fin and above features, hence it is T.S. passing through the **tail region** of *Petromyzon*.

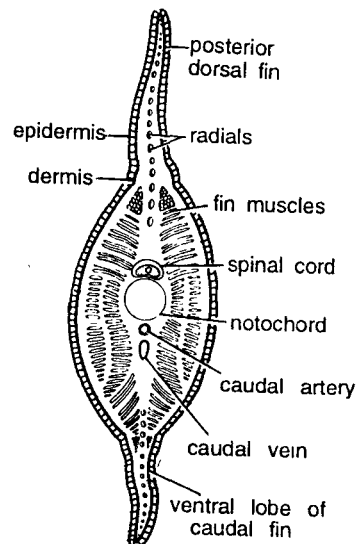

Fig. 18. *Petromyzon* : T.S. passing through tail region.

## C. FISHES

Transverse sections are prepared from specimens that have been preserved and hardened in formalin. With the help of a Butcher's knife or sharp razor, cut the hardened specimen through eye region, olfactory region, branchial region, stomach and liver region, intestinal region, pelvic fin region and caudal region. Study various hand cut sections.

### 19. *Scoliodon* : Hand Cut T.S. Passing Through Eye Region

**Comments :**

- (1) This section can at once be recognized by prominent eyes on the sides.
- (2) Entire section is covered by the integument, which contains several **placoid scales** and **small denticles**.
- (3) **Eyes** are found on either side of the section. Each eye contains **cornea** and **lens**. Eye is innervated by thick **optic nerve**.
- (4) Interior of the section is occupied by the **cartilaginous cranium**.
- (5) In the middle of the section is **brain**.
- (6) On the ventral side **lower jaw** is also seen.
- (7) On the dorsal side several rounded sensory **ampullae of Lorenzini** are seen.
- (8) **Myotomes** are **absent**.

**Identification :** Since this section contains cut eyes at both the ends, hence it is T.S. of *Scoliodon* passing through **eye region**.

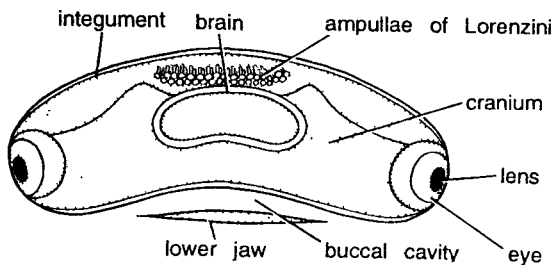

Fig. 19. *Scoliodon* : Hand cut T.S. passing through eye region.

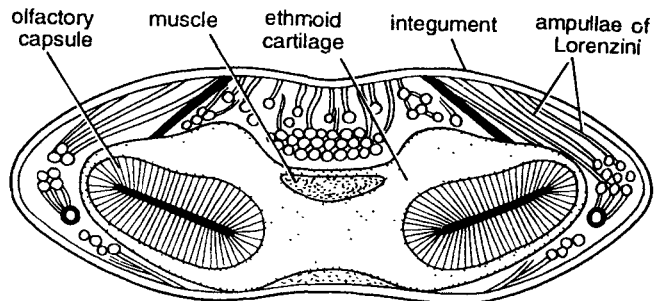

Fig. 20. *Scoliodon* : Hand cut T.S. passing through olfactory region.

### 20. *Scoliodon* : Hand Cut T.S. Passing Through Olfactory Region

**Comments :**

- (1) Section is somewhat oval in outline.
- (2) It is covered by integument on all sides containing **placoid scales**.
- (3) Middle of the section has **muscles**.
- (4) On other side of the section olfactory capsules are seen.

**Identification :** Since this section contains cut olfactory capsules, hence it is T.S. of *Scoliodon* passing through **olfactory region**.

## 21. *Scoliodon* : Hand Cut T.S. Passing Through Branchial Region

### Comments :

- (1) T.S. passing through above region shows **body wall layers, myotomes, spinal cord, notochord, oesophagus, heart and branchii or gills.**
- (2) Section is covered by pigmented **integument** from all sides composed of epidermis and dermis.
- (3) Epidermis contains several dermal placoid scales.
- (4) Dorsal half of the section has thick segmental muscles bundles or **myotomes**, separated by **myocommata**. Myotomes are concentrically arranged.
- (5) In the middle of the muscle layer, cartilaginous vertebra containing **spinal cord** is found.
- (6) **Notochord** is found just below the **spinal cord** and **dorsal aorta** is situated just beneath the **vertebra**.
- (7) **Oesophagus** with thick walls and villi is found just below the dorsal aorta. Beneath oesophagus is pericardial cavity enclosing sinus venosus and the thick-walled ventricle. Below pericardium is the **coracoid cartilage**.
- (8) **Gills**, with gill pouches, are found on the sides of pericardium and coracoid cartilage. Gills occupy entire side of ventral halves. Various cut blood vessels are also seen.

**Identification :** Since this section contains gills and all above structures, hence it is T.S. of *Scoliodon* passing through **gill region**.

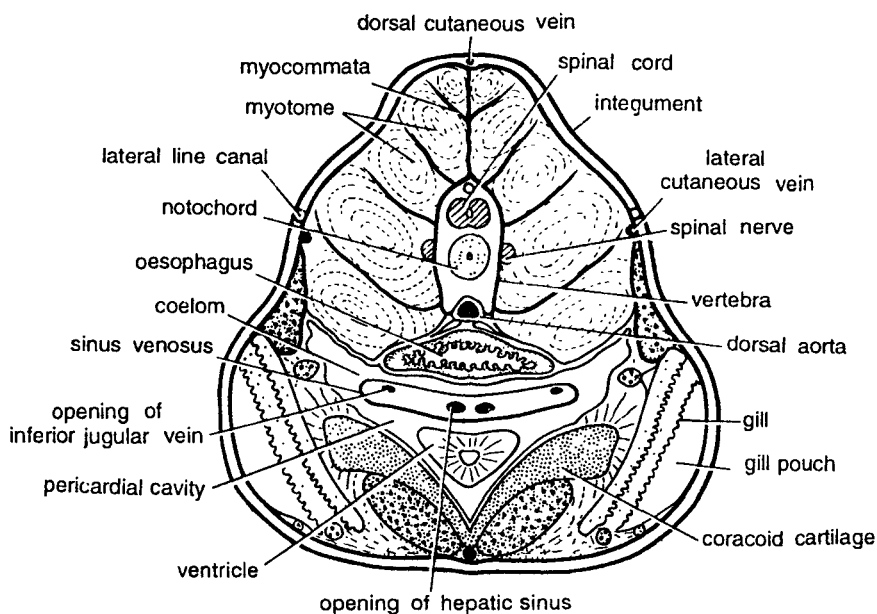

**Fig. 21.** *Scoliodon* : Hand cut T.S. passing through branchial region.



## 22. *Scoliodon* : Hand Cut T.S. Passing Through Stomach and Liver Region

### Comments :

- (1) T.S. passing through above region shows **body wall layers, muscle layer, spinal cord**, stomach and liver. Section is roughly triangular.
- (2) Body consists of integument and muscle layer. Integument is made of epidermis and dermis. Several dermal **placoid scales** are found in the highly pigmented integument.
- (3) **Myotomes** are thick muscle bundles, arranged concentrically and separated by the **myocommata**. Practically entire dorsal half of the section contains segmental **myotomes**.
- (4) In the central axis there is a median vertebra.
- (5) Spinal cord with neurocoel is found in the vertebra and dorsal aorta just below the vertebra.
- (6) **Notochord** is found just beneath the **spinal cord**.
- (7) Ventral half of the section has a spacious **coelomic cavity**, lined by visceral and peritoneal layers and containing visceral organs.
- (8) Thick-walled **stomach** with internal villi is found in the middle. **Kidneys** are found on the sides of **stomach**, while **liver** is found below the stomach.
- (9) Cartilage of pectoral fin, cut portions of cutaneous veins, fifth branchial arch and lateral line canal are seen in the section.

**Identification :** Since this section contains cut stomach and all above structures, hence it is T.S. of *Scoliodon* passing through **stomach and liver region**.

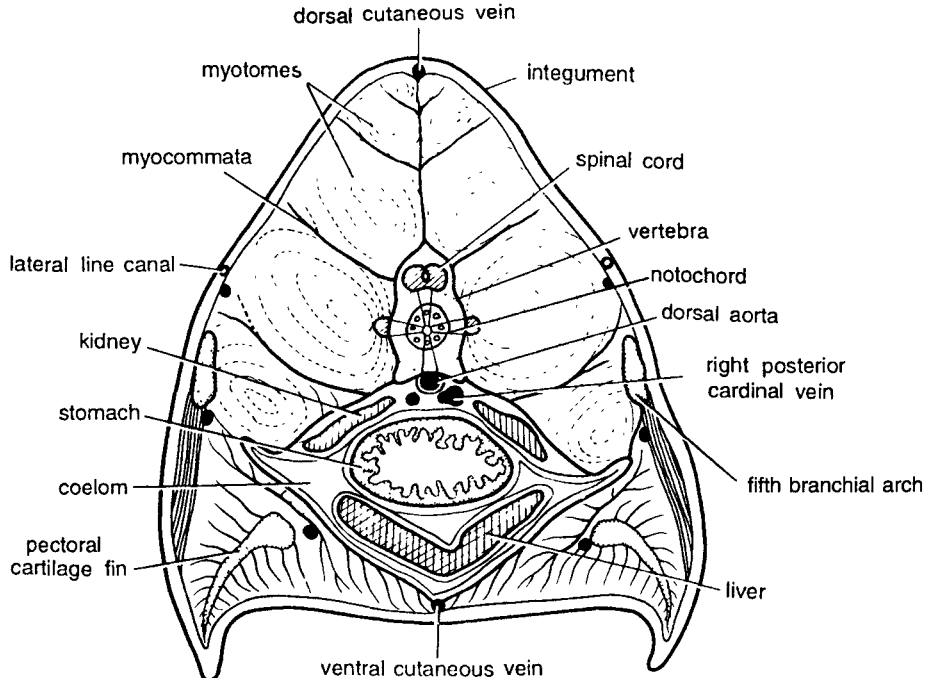

**Fig. 22.** *Scoliodon* : Hand cut T.S. passing through stomach and liver.

## 23. *Scoliodon* : Hand Cut T.S. Passing Through Intestinal Region

### Comments :

- (1) T.S. passing through intestinal region shows **body wall layers, spinal cord, notochord, kidneys, gonads, scroll valve** in the intestine, etc. Section is pointed dorsally.
- (2) Integument with dermal **placoid scales** covers the section from all sides. Body wall consists of epidermis, dermis and musculature.
- (3) **Myotomes** arranged concentrically and **myocommata** occupy more than the dorsal half of the section on each side.
- (4) Vertebra containing nerve cord or **spinal cord** and **notochord** is found in the median axis.
- (5) **Dorsal aorta** is found just below the vertebra.
- (6) **Coelomic** cavity is reduced. It accommodates viscera.
- (7) **Kidneys** are found below **dorsal aorta**. Cut portions of the **seminal vesicles** and **testes** with spermatozoa are found below kidneys.
- (8) **Intestine** is found below seminal vesicles. Internal fold forming anti-clockwise scroll valve is very distinct. Various cut blood vessels, spinal nerves and lateral lines are also seen in the section.

**Identification :** Since this section contains rolled intestine and above features, hence it is T.S. through the intestine of *Scoliodon*.

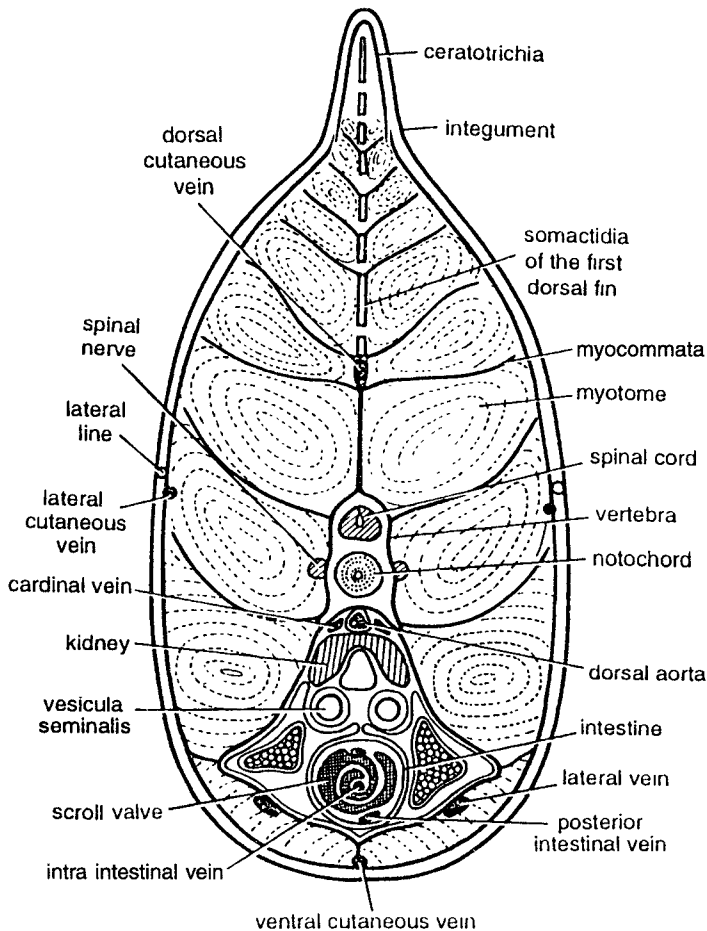

**Fig. 23.** *Scoliodon* : Hand cut T.S. passing through intestinal region.

(Z-21)

## 24. *Scoliodon* : Hand Cut T.S. Passing Through Base of Pelvic Fin of Male and Female

### Comments :

- (1) T.S. passing through the pelvic region shows **body wall layers, nerve cord, notochord, kidney, uterus** in females and **seminal vesicles** in males, etc.
- (2) Body wall is composed of **integument** and **muscle layer**. Integument covers the section from all sides. It consists of **epidermis** and **dermis**. Various **dermal placoid scales** are found in the skin.
- (3) Muscle layer consists of concentrically arranged **myotomes** separated by **myocommata** and they occupy the entire section except some central area for viscera.
- (4) **Vertebra** is found in the central axis. It encloses **spinal cord** and **notochord** in tandem position.
- (5) Coelomic cavity is much reduced.
- (6) **Dorsal aorta** is found just beneath the vertebra.
- (7) Posterior **cardinal vein, kidney** and **ureter** are found below **dorsal aorta**, one after the other, towards posterior side.
- (8) In female *Scoliodon* the two uterii fuse together forming a single **uterus**, which lies the ureters.
- (9) In male *Scoliodon* two **seminal vesicles** lie below the ureters.
- (10) Various cut portions of blood vessels, cartilage of pelvic fin and rectum are also seen in the section.

**Identification :** Since the above sections contain uterus in female and seminal vesicles in male, hence A and B are sections passing through the **pelvic region** of **female** and **male *Scoliodon***, respectively.

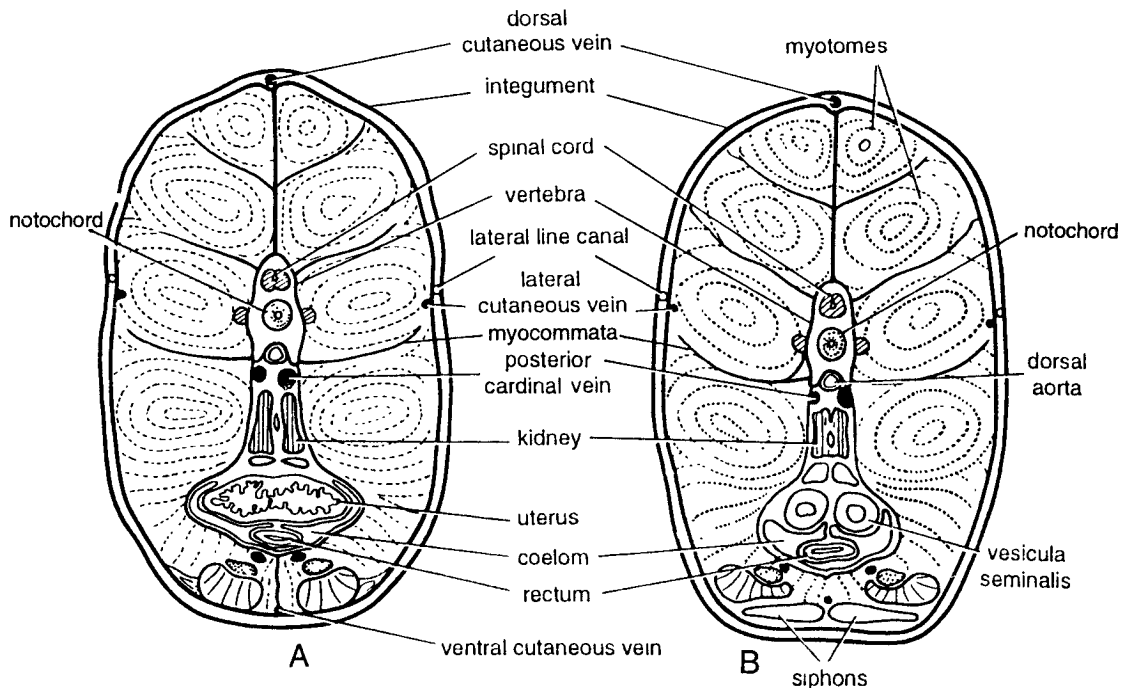

**Fig. 24.** *Scoliodon* : Hand cut T.S. passing through pelvic region. A. Female, B. Male.

## 25. *Scoliodon* : Hand Cut T.S. Passing Through Caudal Region

### Comments :

- (1) T.S. passing through the caudal region shows **body wall**, **caudal vertebra** and **muscle bundles**. No other structure is found in this region.
- (2) Body wall is composed of integument and muscle layer.
- (3) Integument consists of epidermis and dermis. Dermal placoid scales present.
- (4) The concentrically arranged **myotomes** separated by **myocommata** occupy almost entire space of the section.
- (5) Vertebra is found in sub-equatorial mechanical axis. Spinal cord and notochord are enclosed in the vertebra.
- (6) Caudal vein is found below the caudal artery and the latter is found below the vertebra.

**Identification :** Since the above section contains caudal vertebra and above features only hence it is T.S. of *Scoliodon* passing through the **caudal region**.

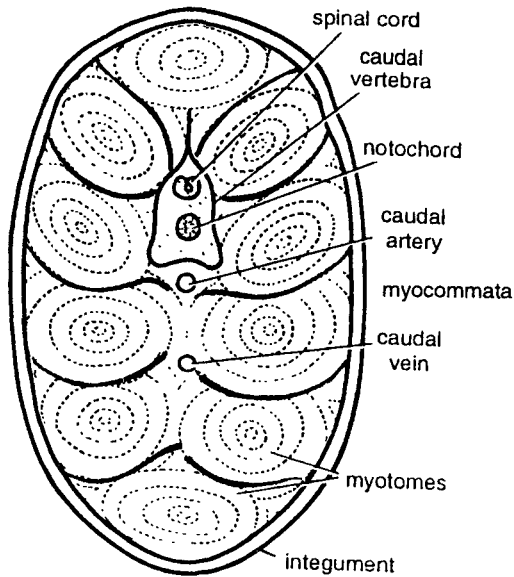

**Fig. 25.** *Scoliodon* : Hand cut T.S. passing through caudal region.

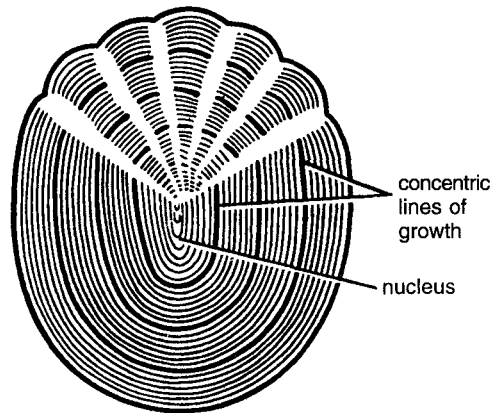

**Fig. 26.** *Labeo* : Cycloid scale.

## 26. *Labeo rohita* : Cycloid Scales

### Comments :

- (1) **Cycloid scales** are found in carps (teleost) and lungfishes (dipnoi). They are located in the dermal pockets and possess concentric lines of growth.
- (2) Each cycloid scale is roughly circular in outline without pulp cavity and with free and smooth border.
- (3) Scales covering lateral line are frequently perforated permitting the passage of small connectives of lateral line to outside.

- (4) **Cycloid scales** are derived form of ganoid scales in which **ganoin**, cosmine and bone cells are lost.  
 (5) Scales are soft, arranged lengthwise in diagonal rows.

**Identification :** Since the above scale contains concentric lines of growth, hence it is **cycloid scale of *Labeo***.

## 27. *Nandus* : Ctenoid Scales

### Comments :

- (1) **Ctenoid scales** are commonly found in most teleost and actinopterygian fishes.
- (2) They are **thin, soft** and dermal **translucent plates**.
- (3) They are composed of underlying fibrous layer covered by bone-resembling layer.
- (4) They contain **concentric rings**, representing **lines of growth** which vary in different specimens.
- (5) Ctenoid scales **do not contain ganoin**.
- (6) Each scales is embedded in a small dermal pocket.
- (7) Scales are obliquely arranged so that posterior end of one overlaps the anterior end of the following scale.
- (8) Basal end is scalloped and free edge bears numerous comb-like projections.
- (9) Ctenoid scales are derivatives of ganoid scales in which ganoin, cosmine layers and bone cells are lost. Pulp cavity and dentine are entirely absent.

**Identification :** Since the above scale has concentric lines of growth with teeth like projections posteriorly, hence it is **ctenoid scale of *Nandus***.

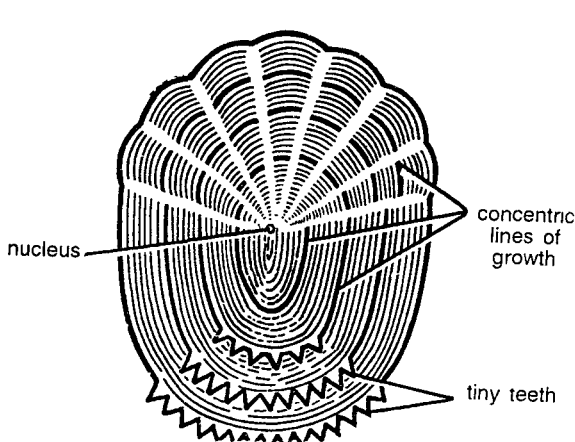

Fig. 27. *Nandus* : Ctenoid scale.

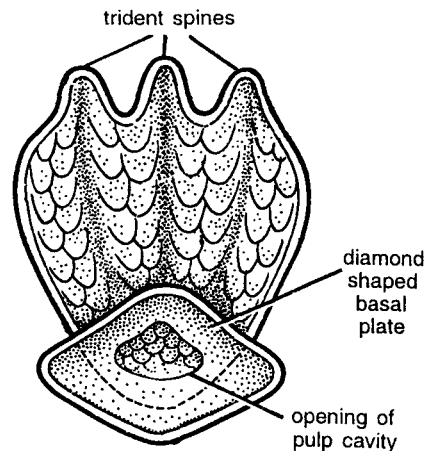

Fig. 28. *Scoliodon* : Placoid scale.

## 28. *Scoliodon* : Placoid Scales

### Comments :

- (1) With very few exceptions, placoid scales are abundantly found in dermis of elasmobranch fishes.
- (2) Placoid scales are arranged in regular oblique rows. They are dermal in origin and cover entire surface of the body, forming dermal exoskeleton of the sharks.
- (3) Each scale is composed of a basal bony plate embedded in the dermis, from which projects trident spines.

- (4) Basal plate is formed of a trabecular calcified tissue.
- (5) Spine is composed of dentine covered by a hard material, vitrodentine.
- (6) Placoid scale contains a pulp cavity in spine.
- (7) Pulp cavity contains odontoblasts dentine forming cells, blood capillaries, nerves and lymph channels.
- (8) General similarity in structure of placoid scales to teeth of higher forms should be apparent. Both are considered to be remnants of bony armour of such primitive vertebrates as ostracoderms and certain placoderms.

**Identification :** Since this scale has trident spines, hence it is **placoid scale of Scoliodon**.

## 29. *Scoliodon* : Development of Placoid Scales

### Comments :

- (1) Development of placoid scale can be studied in a V.S. of integument of dogfish.
- (2) V.S. integument shows 2 layers **epidermis** and **dermis**. Placoid scales originate from dermis. Various development stages of placoid scales are as under.
  - (i) Mesodermal cells accumulate and form **dermal papillae** beneath **stratum germinativum**.
  - (ii) As epidermis is pushed dermal papilla develops **odontoblasts** which deposit **dentine** between themselves and epidermis to form **placoid scale**.
  - (iii) Epidermal cells of papilla are called as ameloblast cells which form **enamel organ** which deposits **vitrodentine** over **dentine**.
  - (iv) In developing placoid scale dermal papilla gives rise to pulp cavity and dentine canaliculi.
  - (v) When fully formed placoid scales project covered by epidermis.
  - (vi) Other structures seen are loose connective tissue, compact connective tissue, vertical fibers, nerve fibers, chromatophores and cement.

**Identification :** Since the section contains dermal papilla and above features, hence it is V.S. of **integument** showing **placoid scales of Scoliodon**.

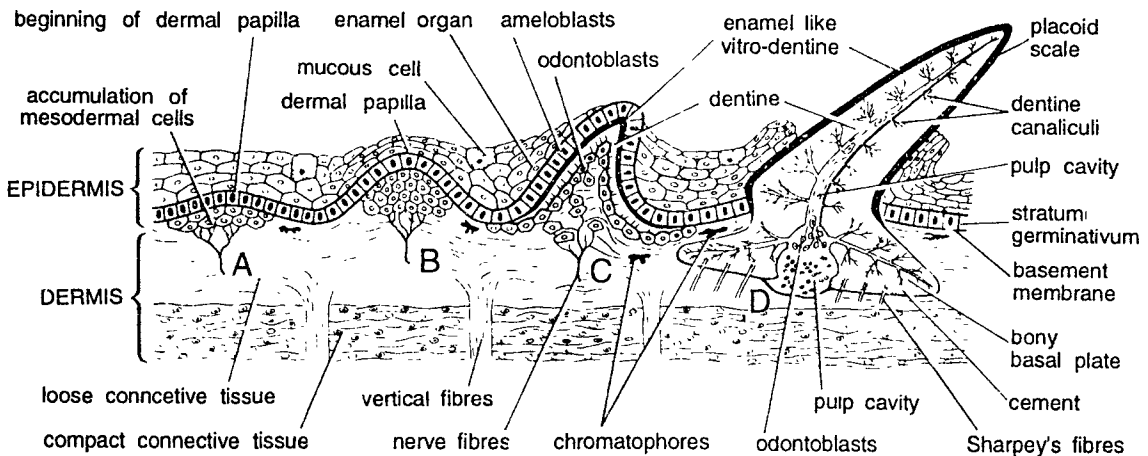

**Fig. 29. *Scoliodon* :** V.S. of skin showing development of a placoid scale. A. Accumulation of dermal cells, B. Formation of dermal papilla, C. Growing spine, D. Fully formed scale.

### 30. *Polypterus* : Ganoid Scales

#### Comments :

- (1) **Ganoid scales** are found in primitive ray-finned fishes such as *Polypterus* and gar pikes.
- (2) Scales are covered with a hard, shiny and translucent material of mesodermal origin called as **ganoin**.
- (3) Ganoid scales fit together like tiles and are arranged in diagonal rows.
- (4) Scales are **dermal in origin**.
- (5) Each scale consists of a bony base, coated by shining substance called as ganoin and openings of **lateral line canal**.

**Identification :** Since the above scale is overlapping and fitted like tiles, hence it is **ganoid scale of *Polypterus***.

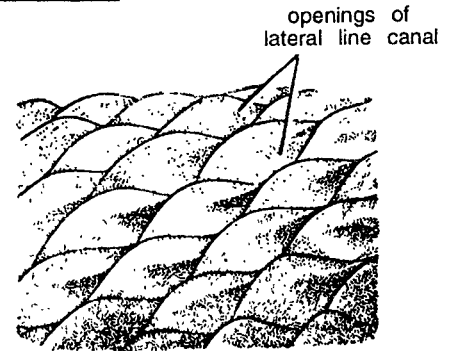

Fig. 30. *Polypterus* : Ganoid scale.

## D. AMPHIBIA

### 31. Frog : V.S. of Skin

#### Comments :

**A. Under low magnification :** (15 X eye-piece; 4 X objective).

- (1) Vertical section passing through the skin reveals two layers, **outer epidermis** and **inner dermis**, distinctly seen under high magnification.
- (2) Epidermis is thin and made up of stratified **squamous epithelium**. Multilayered epidermis is differentiated into two layers : (a) outermost layer is **stratum corneum** and (b) inner layer called as **stratum germinativum** or **stratum malpighi** consisting of single layered closely placed nuclei.
- (3) Beneath the epidermis is thin **basement membrane** and then dermis.

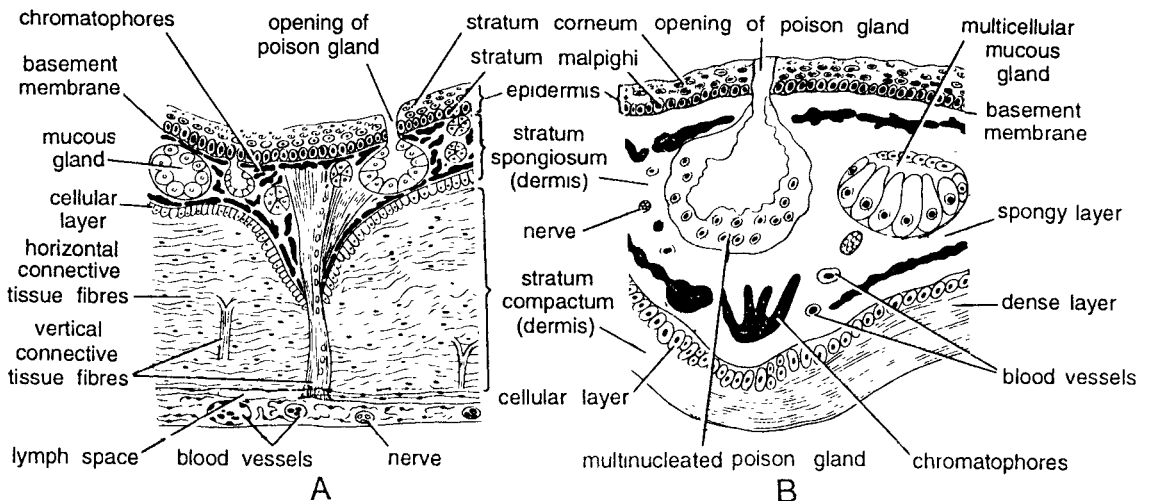

Fig. 31. Frog : A. V.S. of skin, B. A portion of skin greatly modified.

- (4) **Dermis** constitutes major part of the skin and is largely made up of connective tissues. It is distinctly differentiated into two layers. Outer layer is made up of **areolar spongy connective tissue** and hence called as **stratum spongiosum**. It contains **mucous glands**, **poison glands** and **chromatophores**. Inner layer is made up of compact zigzag parallel fibres and hence called as **stratum compactum**. Dermis also contains few **vertical fibers**, **blood vessels** **nerves** and lymph space.
- (5) A cellular layer separates **stratum spongiosum** and **stratum compactum**.
- (6) Just beneath the stratum compactum is lymph layer and then body musculature.
- (7) Connective tissue consists of horizontal connective tissue and vertical connective tissue.

**B. Under high magnification :** (15 X eye-piece; 40 X objective).

All the layers such as **stratum corneum**, **stratum germinatum**, **stratum spongiosum** and **stratum compactum** are clearly seen. Cells of stratum corneum are of varying sizes in the process of keratinization. Cells of stratum germinatum are rounded with a centrally placed nucleus and continuously mitoting. The poison gland has several nuclei (multinucleated) while mucous glands are multicelled structures. Both possess secretory granules. Most distinct structures seen are contracted and expanded **chromatophores** of varying sizes. Vertical connective tissue fibres are also clearly seen.

**Special features :** Skin of frog performs various functions. It is **protective**, **water observant**, respiratory, mucous secreting, sensory, **excretory** and swimming. Skin is an organ consisting of an ectodermal epithelium, the **epidermis**, and its supporting mesodermal connective tissue, the **dermis**. When the cells of stratum corneum die, they are shed off and this is called as moulting.

**Identification :** Since the section has thin epidermis and thick dermis and above features, hence it is V.S. of **skin of frog**.

## 32. Frog : T. S. Passing Through Stomach

**Comments :**

**A. Under low magnification :** (10 X eye-piece; 4 X objective).

- (1) **Stomach** is a broad tube, highly muscularised, having masticatory and digestive function. Histologically **stomach** is composed of **serosa**, **muscle layer**, **sub-mucosa**, **muscularis mucosa** and **mucosa**.
- (2) **Serosa** forms the outermost thin layer. It is derived from visceral peritoneum and is composed of flat squamous cells, called as mesothelium.

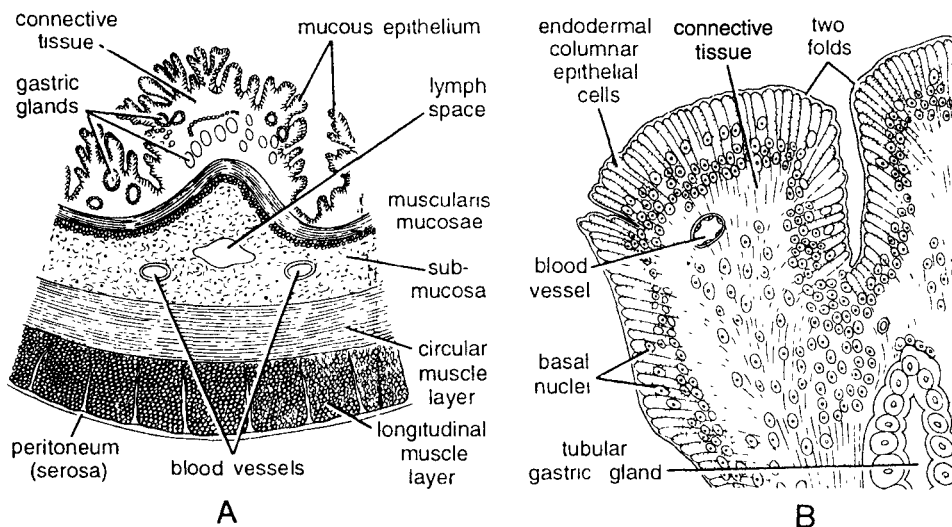

**Fig. 32.** Frog. **A.** T.S. passing through stomach under low magnification. **B.** T.S. passing through part of stomach.



- (3) Muscle layer consists of **outer longitudinal** and **inner circular muscle fibres**.
- (4) Outer longitudinal muscles run longitudinally and are made up of unstriated fibers. By the contraction of longitudinal muscles, stomach becomes shortened and the volume of lumen is widened.
- (5) Inner circular muscles consist of circular fibers. By the contraction of these muscles, stomach increases in the size but the volume of the lumen is reduced.
- (6) By alternate contractions and relaxations of longitudinal and circular fibers, the food is pushed backward and is also masticated.
- (7) Sub-mucosa is made up of the loose **areolar** connective tissue. It serves to bind loosely muscularis mucosa with the muscular coat. It also contains blood vessels.
- (8) **Muscularis mucosa** is a thin layer consisting of **longitudinal** and **circular** layers.
- (9) **Mucosa** is the innermost layer thrown into folds. Mucosa consists of endodermal **columnar epithelial cells**, and connective tissue. Mucosa contains, **oxyntic cells** (HCl secreting), **zymogen cells** (pepsin secreting) and **mucous cells** (mucus secreting). The **villi** are of different sizes.

**B. Under high magnification :** (10 X eye-piece; 40 X objective).

**Endodermal columnar epithelial cells** devoid of goblet cells are clearly seen. Each cell is tall and having basal **nucleus**. Some of the cut tubular glands derived from mucosa are also seen. Substance of each villus contains several nuclei.

**Special features (functions) :** As soon as food reaches into the stomach, its muscular walls masticate the food; its gastric glands secrete digestive enzymes which **hydrolyse** the food. **Pepsin** breaks **peptide bonds** and converts proteins into derived proteins *i.e.*, **peptones** and **proteoses**. HCl kills the bacteria or living food. The secretion of the gastric glands is under **neurohormonal** control.

**Identification :** Since the section has thick musculature and mucosal folds and above features, hence it is T.S. of **stomach of frog**.

### 33. Frog : T.S. Passing Through Duodenum

**Comments :**

- (1) Histologically duodenum resembles with ileum but its mucosa is peculiar. Section shows **serosa, muscle layer, sub-mucosa, muscularis mucosa** and **mucosa**.
- (2) **Serosa** forms outer covering of duodenum. It is derived from the **visceral peritoneum** and is composed of flat squamous epithelial cells, called as **mesothelium**.
- (3) Muscle layer is composed of an outer thinner **longitudinal** and **inner thicker circular** fibres.
- (4) Longitudinal muscles are composed of unstriated fibres. By their contraction, the duodenal tube is shortened but the **volume** of its lumen is **widened**.
- (5) **Circular muscles** consist of circular fibres. By their contraction, the duodenal tube increases in size but the **volume** of its lumen **decreases**.
- (6) Circular and longitudinal muscle layers contain nerves and lymphocytes.
- (7) **Sub-mucosa** is well developed and is composed of loose **connective** tissue. In it the blood vessels and lacteals ramify before entering or after leaving the mucous membrane. It also contains nerves and blood vessels.
- (8) **Mucosa** is thrown into irregular and branched **villi**.

**Special features (functions) :** **Cholecystokinin** and **secretin**, secreted in duodenum stimulate liver to secrete bile and pancreas to secrete pancreatic juice, respectively. In duodenum food is converted into **amino acids** and **polypeptides**, maltose and fatty acids and glycerol.

**Identification :** Since it has thin musculature, long and branched mucosal villi and above, hence it is T.S. of **duodenum of frog**.

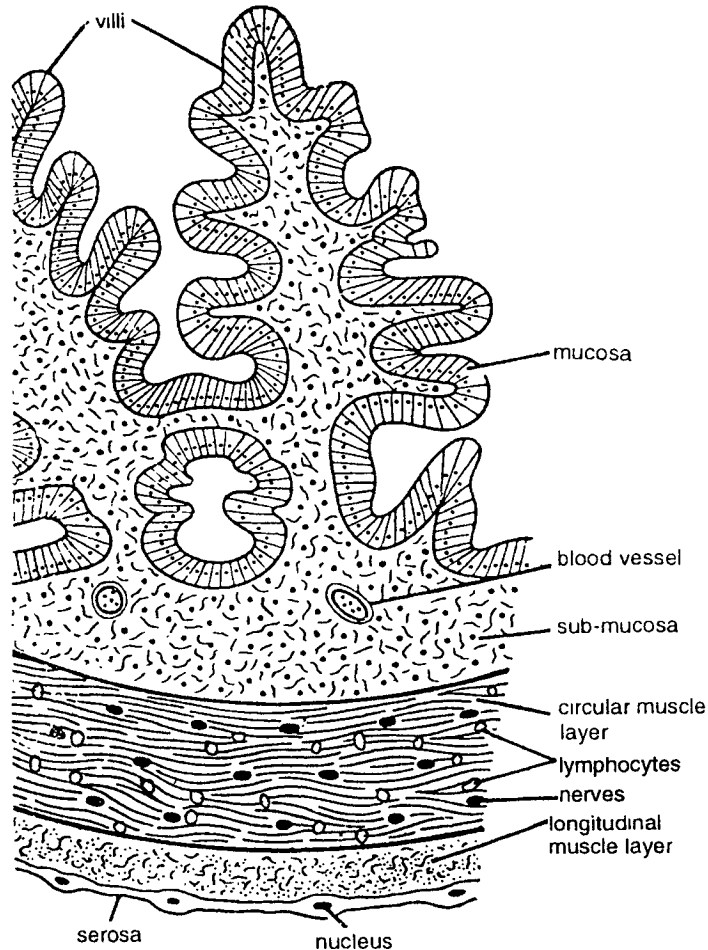

Fig. 33. Frog : T.S. passing through duodenum.

### 34. Frog : T.S. Passing Through Intestine

#### Comments :

A. Under low magnification : (10 X eye-piece; 4 X objective).

- (1) Intestine is modified for absorption and hence it is less muscularised. T.S. passing through it shows **serosa, muscle layer, sub-mucosa, muscularis mucosa and mucosa**.
- (2) **Serosa** coat is complete except over part of the duodenum. Serosa originates from the visceral peritoneal layer and is composed of flat **squamous epithelial cells**, called as **mesothelium**.
- (3) Outer **longitudinal** and inner **circular** muscle layers are distinct.
- (4) Longitudinal layer consists of unstriped fibers. Size of the intestine is decreased and the **volume** of the intestinal lumen is **increased** by the contraction of the longitudinal layer.
- (5) **Circular muscle** fibres form comparatively thick layer than longitudinal **muscle layer**. When they contract, size of the intestine is **increased** and the **volume** of the lumen is decreased.

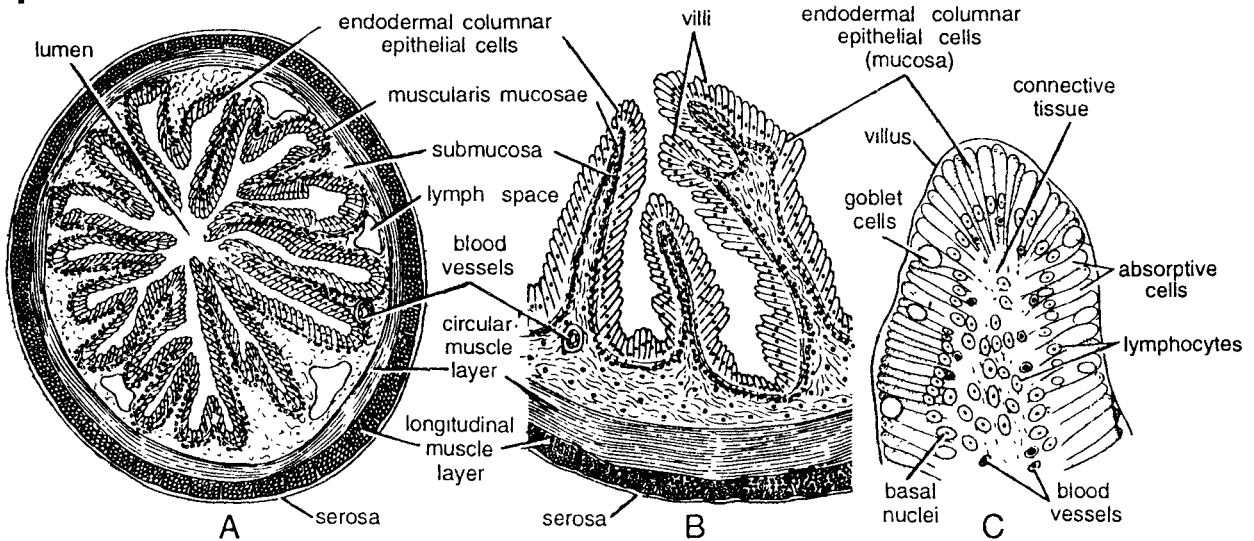

Fig. 34. Frog : A. T.S. passing through intestine. B. A portion of intestine magnified, C. A villus magnified.

- (6) Between longitudinal and circular layers, a network of the **lymphatic vessels** and plexus myentericus, consisting of plexus of **amyelinated** nerve fibres, is found. However this layer is indistinct even in high magnification.
- (7) Sub-mucosa is also well developed, made up of connective tissue and having nerves, rich lymph spaces and blood vessels.
- (8) Blood vessels and lacteals ramify before or after leaving the mucous membrane. Nerve plexus is called as plexus of Meissner.
- (9) Muscularis mucosa is not well developed.
- (10) Mucosa is thrown into villi of different sizes. In a complete cut section [Fig. 34, (A)] the villi occupy most of the space of the lumen. Very small lumen is left. The branching of the mucosa increases the surface area of absorption.

**B. Under high magnification** : (10 X eye-piece; 40 X objective).

The **mucosa** is best seen under this magnification. It is thrown into many simple villi consisting of tall elongated **endodermal columnar epithelial cells**. Each cell has basal nucleus. Intermingled with epithelial cells are **goblet cells** and **absorptive cells**. **Lymphocytes** are also seen. Tubular glands are absent. The substance of villi contains several nuclei.

**C. Magnified villus** shows **endodermal columnar epithelial cells**, **goblet cells** basal nuclei, blood vessels connective tissue and lymphocytes.

**Special features (functions)** : **Goblet cells** secrete mucous, while absorptive cells absorb food material. Intestinal enzymes are peptidases, maltase, lipase, invertase and lactase, which hydrolyse the food into amino acids sugar, fatty acids and **glycerol**, **glucose** and **fructose** and **glucose** and **galactose**, respectively.

**Identification** : Since it has goblet cells in mucosal folds, and all above features, hence it is T.S. of **intestine of frog**.

### 35. Frog : T.S. Passing Through Liver

#### Comments :

#### A. Under low magnification : (15 X eye-piece; 4 X objective).

- (1) Amphibian liver is **dark chocolate** coloured and large in proportion to the size of the body. The liver of frog contains three unequal lobes but connected with each other. T.S. passing through the liver shows the following histological details.
- (2) It is a solid **glandular** organ, made up of rounded **hepatic lobules** or **acini** in the form of branched columns, separated from one another by the connective tissue. Externally it is covered by serous coat.
- (3) Each acini or hepatic lobule contains roughly 5 to 10 **hepatic cells** which are penetrated by fine network of connective tissue and sinusoid vessels called as hepatic capillaries.
- (4) **Portal vein, afferent** blood vessel and **hepatic** artery enter its undersurface, where bile duct passes from the gland. Fine branches from above three form interlobular and intralobular vessels. Vessels are indistinct.
- (5) Bile ducts and **bile canaliculi** are also seen.
- (6) Each **hepatic cell** is rounded and nucleated.
- (7) **Glycogen** formation occurs in the middle of the lobule, while peripheral area secretes bile.
- (8) Large ducts drain bile capillaries and they unite to form hepatic duct.
- (9) Bile secreted by liver is stored into large pear-shaped saccular structure, called as gall bladder.

#### B. Under high magnification : (10 X eye-piece; 40 X objective).

Hepatic acini and hepatocytes are very distinct. Each hepatocyte is rounded and contains one or **two nuclei**. **Hepatocytes** with two nuclei appear to be in mitotic stage. Cytoplasm is granular. Wall of the sinuses contains spindle-shaped **Kupffer cells** of **phagocytic** nature.

**Special features (functions)** : Liver has the following functions : (i) It secretes bile juice, consisting of bile salts, bile pigments, **cholesterol** and lecithin, which act as fat emulsifier. (ii) It **stores glycogen**, **inorganic salts of iron and copper**. **Glycogenesis** and **glycogenolysis** take place in liver, (iii) Liver

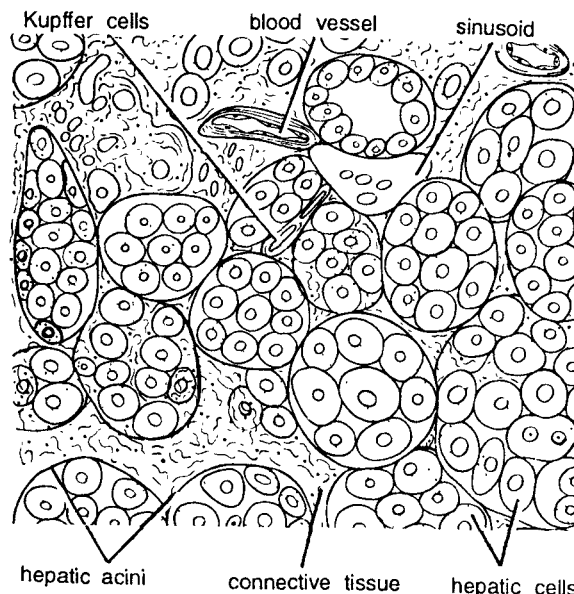

Fig. 35. Frog : T. S. passing through liver.

produces **fibrinogen** and **prothrombin**, which are essential components of clotting of blood. It produces heparin, which prevents blood clotting, (iv) Liver changes ammonia into urea. **Urea synthesis** takes place by **ornithine cycle**. This process is also called as **deamination**. (v) Liver also controls **oxidation** of sugar, (vi) It is excretory, (vii) In embryonic condition liver produces **blood corpuscles**, (viii) Various enzymes are synthesized in liver, (ix) Liver also stores and synthesizes **vitamins**, (x) Liver is a very important organ for **metabolism**.

**Identification :** Since it has rounded hepatic lobules, and all above features hence it is T.S. of **liver of frog**.

### 36. Frog : T.S. Passing Through Pancreas

**Comments :**

**A. Under low magnification :** (7 X eye-piece; 4 X objective).

- (1) Pancreas is noteworthy because in amphibians one or more pancreatic ducts open either directly into duodenum or indirectly through bile duct.
- (2) Pancreas is a large and yellow-coloured compound **tubulo-alveolar gland**, situated between duodenum and stomach, and covered with coelomic epithelium.
- (3) Histologically it is composed of several **lobules** or **acini**, connected by loose connective tissue, nerves and blood vessels. **Pancreatic acini** represent the secretory part of gland. Cut lobules may be rounded or tubular.
- (4) Under low magnification the **cellular** organization is not very clear but the same could be clearly studied under high magnification.
- (5) Large **veins** and **arteris** and several blood capillaries lie in the connective tissue.
- (6) Centre of the acinus communicates with the nearest duct and it secretes digestive enzymes.
- (7) Lightly coloured **islets of Langerhans** are scattered groups of cells surrounded by pancreatic acini.
- (8) Central mass is peculiar and contains special cells, called as **islets of Langerhans**.
- (9) Pancreas is very vascular and also innervated by **parasympathetic nerves**.

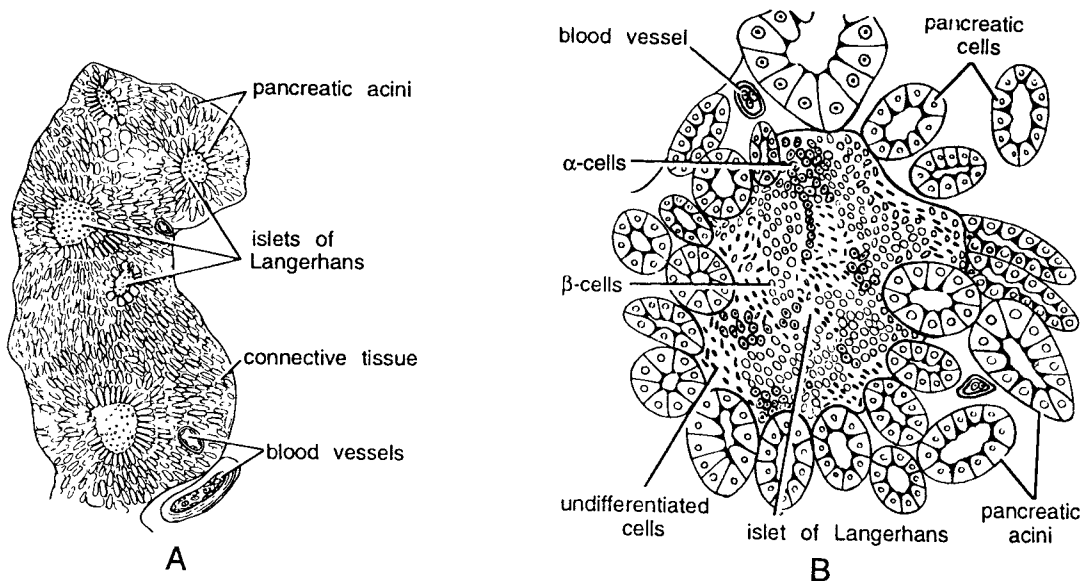

**Fig. 36.** Frog : **A.** T.S. passing through pancreas, **B.** T. S. of pancreas. A portion under high magnification.

**B. Under high magnification :** (15 X eye-piece; 40 X objective)

Each lobule or acinus is made up of 13 to 15 cells. Wall of each acinus is made up of **columnar** or **pyramidal** cells. Each cell is differentiated into two zones— a basal zone containing rounded nucleus and some basophilic coarse granules and luminal zone with fine granules. In the scattered group of islets of Langerhans 3 kinds of cells are clearly seen – (i) darkly stained **alpha ( $\alpha$ ) cells** secreting **glucagon**, (ii) lightly stained rounded **Beta ( $\beta$ ) cells** secreting **insulin** and (iii) dot-shaped **undifferentiated** cells of unknown function. Cells of lobules may be squamous or cuboidal.

**Special features (functions) :** Pancreas plays a dual role in the body, serving both as **exocrine** and **endocrine** glands. **Exocrine secretion** consists of digestive enzymes, such as **amyllopsin**, **trypsin** and **lipase**. Endocrine secretion is that of **islets of Langerhans** which produce **insulin** and **glucagon**, secreted by  **$\beta$ -cells** and  **$\alpha$ -cells**, respectively. Insulin plays an important role in **carbohydrate metabolism**. It regulates blood sugar level. Its deficiency causes a disease, called as **diabetes**. Glucagon increases the blood sugar level. Its deficiency causes **hypoglycemia**.

**Identification :** Since the above section contains pancreatic lobules and islets of Langerhans and all above, hence this is T.S. of **frog** passing through **pancreas**.

### 37. Frog : T.S. Passing Through Spleen

**Comments :**

- (1) **Spleen** is a small, rounded and dark brown structure, found above rectum.
- (2) Spleen is covered with a fibrous and muscular capsule and externally covered by visceral peritoneum.
- (3) **Capsule** sends bands or **trabeculae**, which ramify into the substance of the gland.
- (4) Into the network of the **trabeculae** there is a soft pulpy mass, called as **splenic pulp**.
- (5) Spleen T.S. shows presence of centrally located **red pulp** and **white pulp**.

**Special features (functions) :** (i) B-lymphocytes produce antibodies, (ii) Spleen stores and **synthesizes leucocytes** (W.B.C.). Spleen is dilatible and contractile, (iii) It contains **macrophages**, which are responsible for the destruction of old erythrocytes. (iv) In embryonic condition it produces **erythrocytes** but after birth **leucocytes** are produced.

**Identification :** Since the above section contains red pulp, white pulp and trabeculae and all above features, hence it is T.S. of **spleen of frog**.

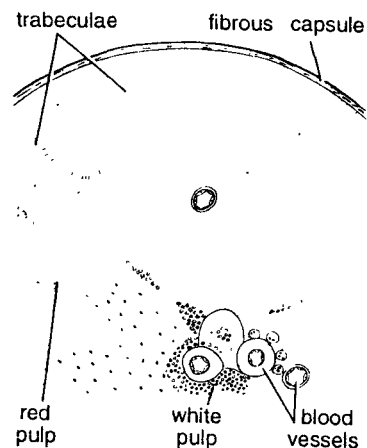

Fig. 37. Frog : T.S. passing through spleen.

### 38. Frog : T.S. Passing Through Lung

**Comments :****A. Under low magnification :** (7 X eye-piece; 4 X objective).

- (1) There is a pair of sac-like lungs, one on either side of heart. Lung of frog is not much elongated, but it is well developed having more alveolar spaces and rich blood supply.
- (2) T.S. of lung shows **peritoneal layer**, **lung wall**, **alveoli** and a **central cavity**.

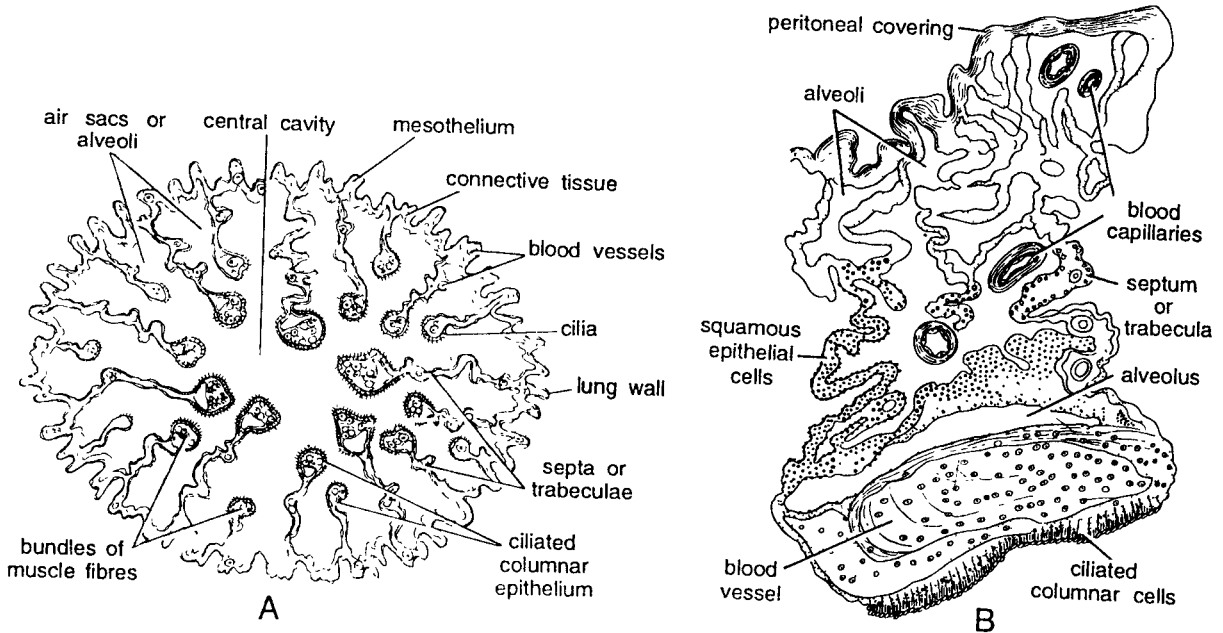

Fig. 38. Frog : A. T.S. passing through lung under low magnification, B. A portion highly magnified.

- (3) Lung wall is composed of outer peritoneum made-up of **squamous epithelial cells**, connective tissue and unstriped muscle fibres. Inner wall is composed of **ciliated epithelial cells**, mucous glands and **blood capillaries**. Mucous glands are indistinct.
- (4) **Blood capillaries** from network.
- (5) Central cavity is partly divided into numerous chambers or **alveoli**, partitioned by **trabeculae**.
- (6) Trabeculae partly contain flattened **squamous epithelium** and partly **ciliated columnar epithelial cells**. They are richly vascularised and contain several nuclei.
- (7) **Alveoli** and trabeculae increase the respiratory surface.

**B. Under slightly high magnification :** (7 X eye-piece; 10 X objective).

**Squamous epithelial lining on trabeculae** and expanded **ciliated epithelial cells** are very clear. Nuclei are concentrated on the sides of the trabeculae and the expanded cells. Other structures seen are mesothelium, connective tissue blood vessels, trabeculae, alveolis.

**Special features (functions) :** Lung is an important **respiratory organ** meant for **external respiration**, where oxygen from the atmosphere is taken to combine with haemoglobin forming **oxyhaemoglobin**. From the lungs oxyhaemoglobin is transported to cells for tissue or **cellular respiration**.

**Identification :** Since it has alveoli and air spaces and all above features, hence it is section of **lung of frog**.

### 39. Frog : T.S. Passing Through Spinal Cord

**Comments :**

**A. Under low magnification :** (7 X eye-piece; 4 X objective).

- (1) Medula oblongata after emerging from foramen magnum, and continues posteriorly as spinal cord.
- (2) T.S. of **spinal cord** shows that it is coated by outer durameter and inner piameter.
- (3) **Bioplasm** of the nerve cord is divided by dorsal and ventral fissures and is differentiated into **outer white matter** and **inner grey matter**.

- (4) White matter is devoid of nerve cells and represents lighter area.
- (5) Grey matter contains nerve cells and a **central canal**, which is continued with the ventricles of brain. It is lined by a single epithelial layer; called as **ependyma**.
- (6) **Grey matter** forms squarish area, but **dorsal and ventral horns** are not very much distinct.
- (7) In mid-dorsal axis, **dorsal and ventral fissures** are seen.

**B. Under high magnification :** (10 X eye-piece; 40 X objective).

Practically half of the outer peripheral portion of the spinal cord is occupied by the grey matter. **Neurons** are heavily concentrated. In mid dorsal axis, dorsal and ventral fissures are very clear.

**Special features (function) :** Spinal cord has the following functions : (i) It receives stimulus from dorsal and ventral roots, (ii) It transmits impulses to the brain, (iii) It causes reflex action.

**Identification :** Since it has white matter and grey matter and all above features, hence it is T.S. of **spinal cord of frog**.

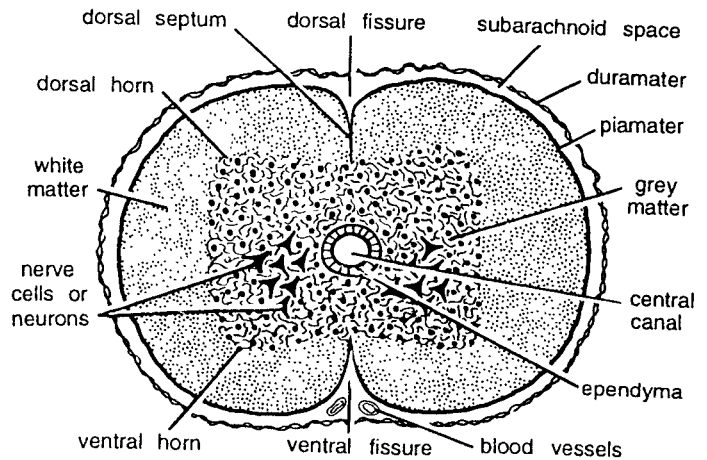

Fig. 39. Frog : T.S. passing through spinal cord.

## 40. Frog : T.S. Passing Through Kidney

**Comments :**

- A. Under low magnification :** (7 X eye-piece; 4 X objective).
  - (1) Kidney of adult frog is opisthonephros.
  - (2) There are two kidneys, each representing a compound tubular gland. T.S. passing through a kidney shows **nephrostomes**, **uriniferous tubules** and **Bowman's capsules**.
  - (3) Each kidney is bean-shaped structure covered by visceral **peritoneal layer**.
  - (4) Interior of the kidney is filled with large number of uriniferous tubules cut in various planes.
  - (5) **Nephrostomes** are funnel-like structures communicating with the coelom and to the vein of kidney.
  - (6) **Bowman's capsules** are cup-shaped structures, containing tuft of blood vessels called as **glomerulus**.
  - (7) Bowman's capsule and glomerulus are collectively called as **Malpighian body**. These capsules are concentrated towards ventral region.
  - (8) **Renal arteries** and renal veins are cut at several places in section.
- B. Under high magnification :** (10 X eye-piece; 40 X objective).
  - (9) **Nephrostome** or **coelomic funnel** is in the form of wide opening and it leads into collecting chamber and then into tubule. Other structures are Bowman's capsule, glomerulus, uriniferous tubules, renal arteries and peritoneal covering.
  - (10) Figure. 40, B shows a portion of kidney with uriniferous tubules which are very much convoluted and made up of **granular**, **ciliated** and **nucleated** epithelial cells. Various uriniferous tubules cut in transverse and longitudinal plane are seen.
  - (11) Figure. 40, C under high magnification shows double-walled Bowman's capsule and glomerulus with wide **afferent** and narrow **efferent** network of capillaries forming **glomerulus**. The capsule has several nuclei of different sizes, blood vessels and squamous epithelial cells.



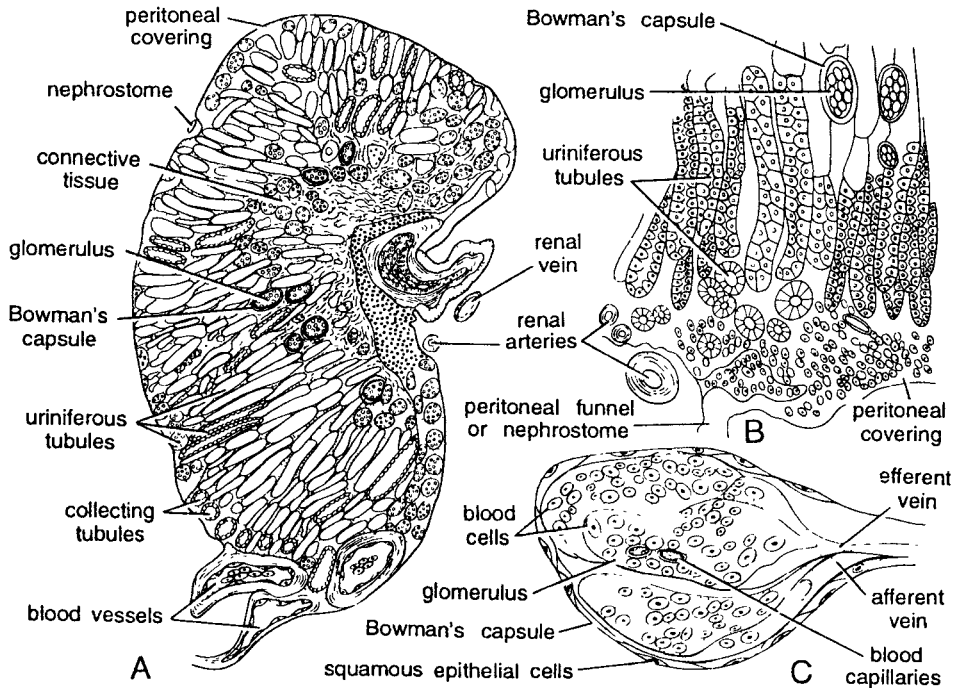

Fig. 40. Frog : A. T.S. passing through kidney under low magnification, B. A portion of uriniferous tubules under high magnification, C. Bowman's capsule.

**Function of kidney :** It functions to stabilize blood stream by filtration extracting water, urea, uric acid, phosphates and sulphates, etc. Various diseases associated with kidney are **glycosuria**, **albuminuria** and **nephritis**, etc.

**Identification :** Since the section has glomerulus and Bowman's capsule, hence it is T.S. of **kidney of frog**.

### 41. Frog : T.S. Passing Through Testis

**Comments :**

**A. Under low magnification :** (7 X eye-piece; 4 X objective).

- (1) T.S. passing through testis shows that it is made up of **peritoneal epithelium**, **tunica albuginea**, **blood vessels**, **intertubular connective tissue** and **mesorchium**.
- (2) Testis are attached with kidney with mesorchium.

**B. Under high magnification :** (15 X eye-piece; 40 X objective).

- (3) T.S. of a seminiferous tubule shows that it is composed of a **germinal epithelium** which gives rise to spermatogonia or sperm mother cells.
- (4) Other stages are spermatocytes, spermatids and sperms representing various stages of spermatogenesis are seen in the section.
- (5) Section shows cut blood vessels and inter-tubular connective tissue.
- (6) In section interstitial cells primary spermatocytes, secondary spermatocytes, spermatids and sperms are seen.

(Z-21)

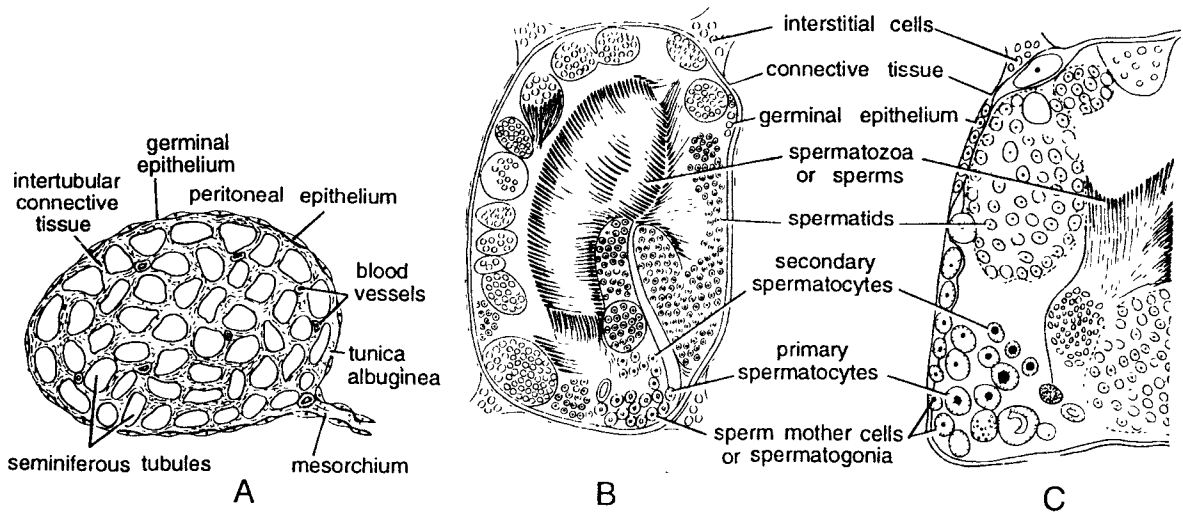

Fig. 41. Frog : A. T.S. passing through testis under low magnification, B. T.S. of seminiferous tubule, C. A portion of tubule high magnification.

- (7) **Interstitial cells** present in the section secrete male hormone **testosterone**, which is responsible for developing secondary sexual characters.
- C. **In high magnification** : Various stages during **spermatogenesis** are clearly seen. The sperms mother cell or **spermatogonia** lie at the peripheral surface of seminiferous tubules. The **primary spermatocytes** are the largest cells having large nuclei. **Secondary spermatocytes** are smaller than primary having deeply stained nuclei. The spermatids are darkly stained still smaller rounded structure. Deep blue haematoxylin-stained spermatozoa with tails are present in large number. Intertubular connective tissue contains blood vessels and **interstitial cells**. Testis is coated with fibrous **tunica albuginea** and then by **peritoneal epithelium**.

**Function** : It produces sperms.

**Identification** : Since sections contains sperms and above features, hence it is T.S. of **testis of frog**.

## 42. Frog : T.S. Passing Through Ovary

**Comments** :

**A. Under low magnification** : (10 X eye-piece; 4 X objective).

- (1) There are **two ovaries** attached to kidneys by **mesovarium**.
- (2) Each ovary is composed of several hollow lobules containing developing ova in various stages of development, connective tissues, young follicles, blood vessel, primary oocytes germinal epithelium and theca.

**B. Under high magnification** : (10 X eye-piece; 40 X objective).

- (3) Each lobule is surrounded by **theca externa**, **theca interna**, **germinal epithelium**, follicular cells and ova in various stages of development.
- C. An **ovum under high magnification** shows **theca externa**, **theca interna**, **yolk granules**, cytoplasm and nucleus.

**Identification** : Since A, B and C contains ova and above features, hence it is T.S. of **ovary of frog**.

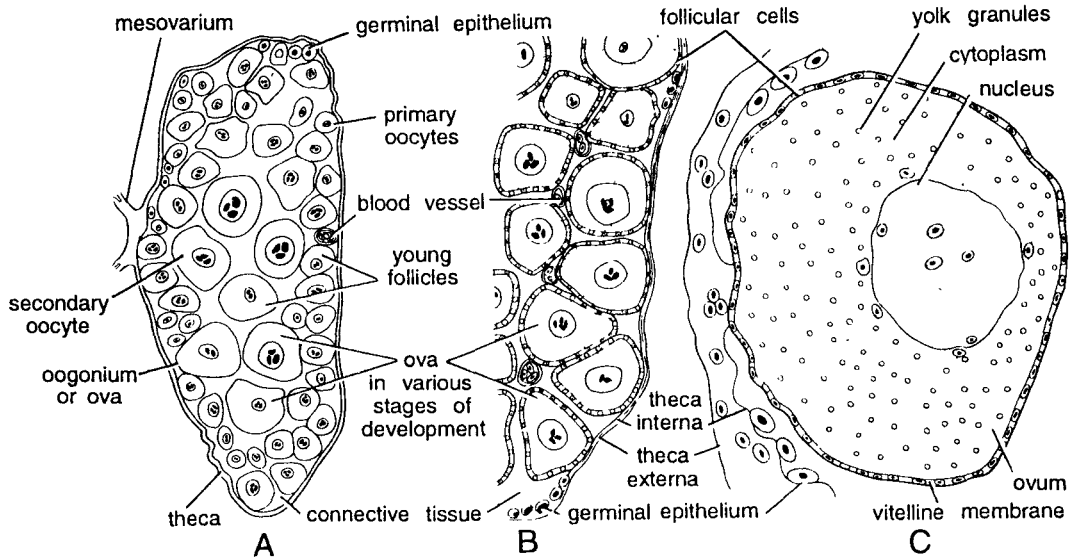

Fig. 42. Frog : A. T.S. passing through ovary, B. A portion of ovary under high magnification, C. An ovum under high magnification.

### 43. Frog : T.S. of Bone

#### Comments :

**A. Under low magnification :** (10 X eye-piece; 4 X objective).

T. S. bone shows outer **periosteum**, then **outer zone of bone layer**, **inner zone of bone layer**, **bone marrow** and **central narrow cavity or canal**.

**B. Under high magnification :** (10 X eye-piece; 40 X objective).

- (1) Outer most layer **periosteum**.
- (2) Below periosteum is outer **osteoblast layer**.
- (3) Beneath outer blast layer are lamellae **osteocyte cells** and **inner osteoblast layer**.
- (4) Innermost in **endosteum** enclosing bone marrow.

**Identification :** Since the above section has osteocyte cells and above features hence it is in T. S. of **bone of frog**.

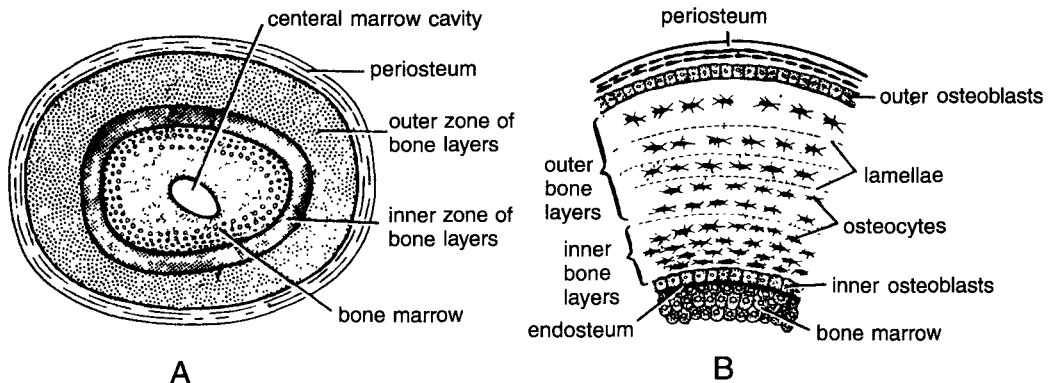

(Z-21)

Fig. 43. Frog : T.S. bone, A. Under low magnification, B. Under high magnification.

## E. REPTILE

### 44. Lizard : V.S. of Skin

#### Comments :

- (1) T.S. skin of lizard shows **outer epidermis** and **inner dermis**.
- (2) Epidermis contains **horny epidermal scales** characteristic of reptilian skin.
- (3) Various layers of epidermis are **stratum corneum** followed by **stratum germinatum** or **stratum malpighii** from which new skin develops.
- (4) Below **stratum germinatum** in loose connective tissue. **Dermal papilla** present beneath stratum germinatum.
- (5) **Dermis** is composed of **fibrous connective tissue** and conjunctiva tissues.
- (6) Dermis contains muscles, nerves blood vessels and chromatophores.

**Identification :** Since the section contains epidermal scales and above features, hence it is V.S. skin of lizard.

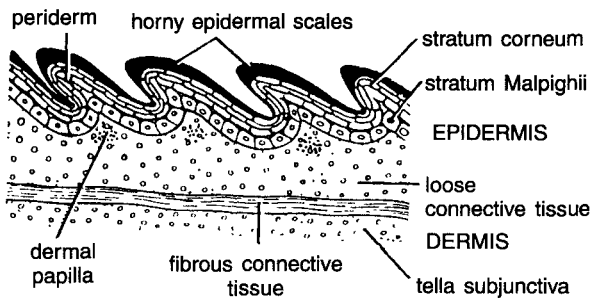

Fig. 44. Lizard : V.S. of skin.

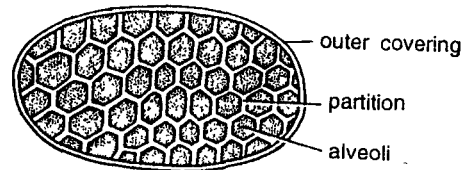

Fig. 45. Lizard : V.S. passing through lung.

### 45. Lizard : V.S. of Lung

#### Comments :

- (1) V.S. lung of lizard shows outer **serosa** enclosing lung **alveoli**.
- (2) Inner lining of lung is raised into number of septa like structures, enclosing air sacs or **alveoli**.
- (3) Lung contains rich **blood supply**.
- (4) Alveoli are separated by septa.
- (5) Anterior lung is more sacculated thicker and richly vascularised.
- (6) Lung cavity is continuous.
- (7) Bronchus entering into lung does not branches into bronchioles but it directly forms alveoli.
- (8) In lungs deoxygenated blood is brought by pulmonary artery and oxygenated blood carried away by pulmonary vein.

**Identification :** Since the lung shows alveoli and above features, hence it is V.S. of lung of lizard.

## F. BIRD

### 46. Bird : V.S. of Skin

#### Comments :

- (1) V.S. skin of pigeon shows main two layers : **Epidermis, Dermis.**
- (2) Epidermis contains the following layers : (i) Outermost layer is called as **epitrichium** made up delicate cells, (ii) Below epitrichium is cornified layer called as **stratum corneum**. (iii) Beneath stratum corneum is **stratum germinatum** or **stratum Malpighii** consisting dividing cylindrical and uninucleated cells.
- (3) Dermis is made up of following layers : (i) **Vascular spongy layer** just beneath stratum germinatum. It has such **blood supply, nerves, muscles, connective tissue**, (ii) Below spongy layer is **compact layer** of fat.
- (4) In the section **dermal papilla** for permanent feather, feather follicle, pulp, calamus of down feather with barbs are seen.
- (5) Only gland present is **preen gland** or uropygial gland near tail.

**Identification :** Since the section contains calamus and above features hence it is V.S. of **skin of pigeon** (bird).

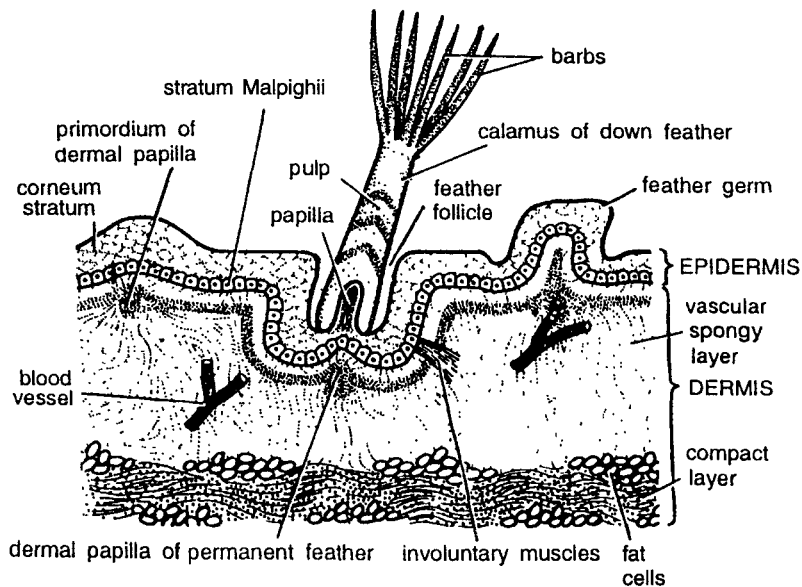

Fig. 46. Bird : V.S. of skin.

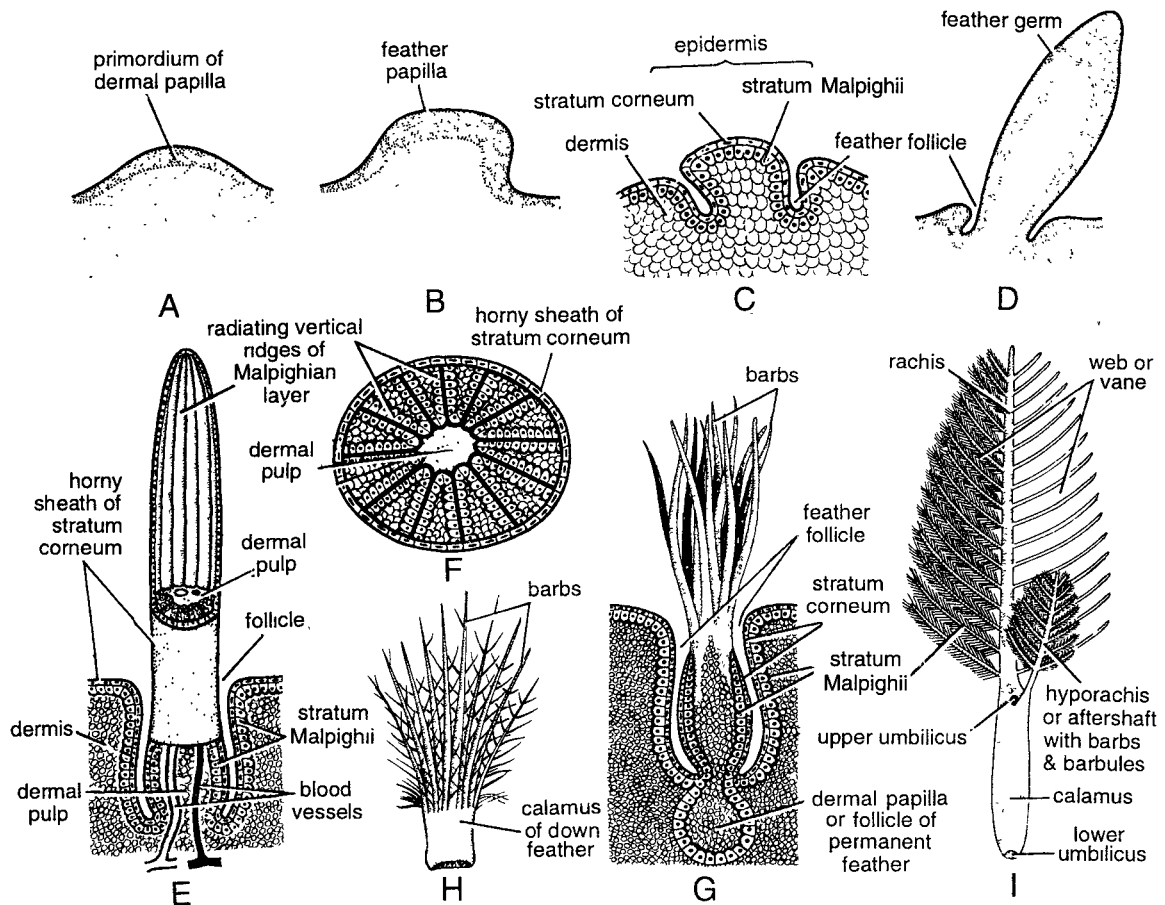

Fig. 47. Bird : Development of feather.

## 47. Pigeon : Development of Down and Contour Feather

### Comments :

- (1) At 5th or 6th day of incubation feather starts developing as primordium **dermal feather papilla** or **pimple** over the skin (A, B).
- (2) Each **papilla** arises as group of cells beneath delicate and transparent epidermis the papilla rudimentary **down feather** (C)
- (3) Base of **papilla** sinks and forms **feather follicle**. From feather follicle it grows as **feather germ** (D).
- (4) Base of feather germ lies in stratum germinatum which forms series of vertical radiating ridges which later on differentiate into **rami** or **barbs** lower part of feather forms thickened bare or **quill** (E, F).
- (5) A transparent sheath originating from **stratum germinatum** encloses growing feather. The central soft mass forms the pulp which is nutritive zone for the feather (G, H).
- (6) Later on **barbules** developed.
- (7) As the feather grows, it is peald off and feather with barbs emerges.
- (8) In case of contour feather fresh papilla is formed at a deeper level. In case of contour feather the ridges of Malpighian layer give rise to **rachis** or shaft containing barbs (I).

**Identification :** As the slide contains dermal papilla and above features, hence it is in V.S. **development of feather of pigeon.**

### 48. Pigeon : L.S. of Crop

**Comments :**

- (1) Section shows outer covering made up elastic thin layer.
- (2) Internally crop contains epithelial layer and crop glands.
- (3) During reproduction the glands secrete delicate nutritive substance called pigeon milk. The pigeon milk is secreted by both sexes. Pigeon milk is fed to young pigeons by beak. It is regurgitated into the mouth by parents until young are able to feed on grains.
- (4) The epithelial layer also contains mucus glands.

**Identification :** Since the section contains crop glands and above feature, hence it is L.S. of **crop of pigeon**.

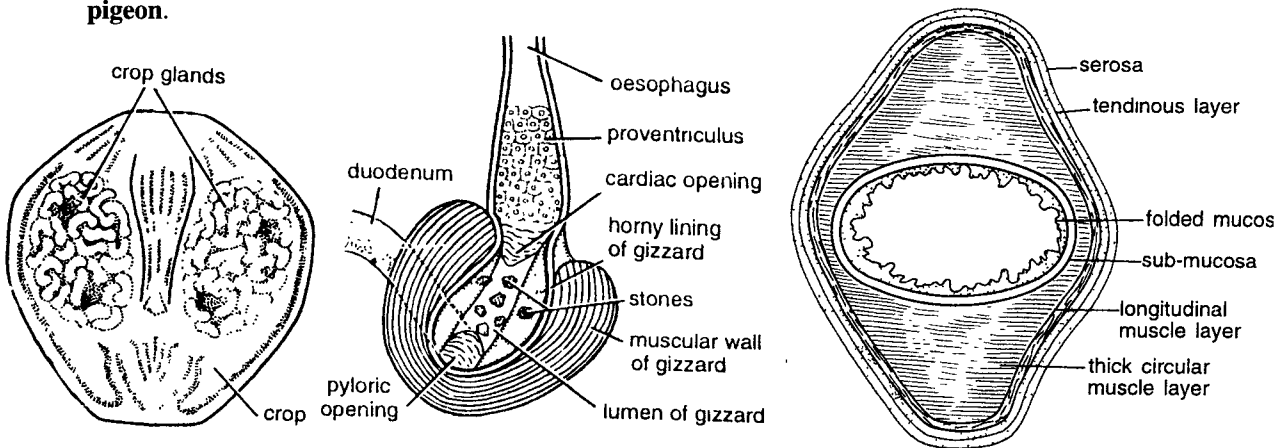

Fig. 48. Pigeon : T.S. passing through crop.

Fig. 49. Pigeon : V.L.S. of proventriculus.

Fig. 50. Pigeon : T.S. passing through gizzard.

### 49. Pigeon : V.L.S. of Proventriculus

**Comments :**

- (1) Part above gizzard is called is proventriculum. Section shows that proventriculus opens into gizzard by cardiac opening.
- (2) Interior of proventriculus contains thick mucous glands which secrete gastric juice.

**Identification :** Since the section contains thick mucous gland and above features, hence it is V.L.S. of **proventriculus of pigeon**.

### 50. Pigeon : T.S. Passing Through Hand Cut Section of Gizzard

**Comments :**

- (1) Gizzard is highly thick and muscular. T.S. passing through gizzard shows that it is composed of **serosa, tendinous layer, folded mucosa, longitudinal muscle layer and thick circular muscle layer**.
- (2) Lumen of gizzard is surrounded by thick rough, horny, yellow or green coloured epithelial linings which make gizzard very narrow.
- (3) Horny lining contains pieces of stones which help in grinding of food.

**Identification :** Since the lumen contains horny lining and stones, hence it is T.S. of **gizzard of pigeon**.

## G. MAMMALIA

### 51. Rabbit : V.S. of Skin

#### Comments :

- (1) Mammalian skin is characterized by having various **glands** and **hairs** in abundance.
- (2) T.S. through skin shows that it is an organ consisting of an **ectodermal epithelium**, the **epidermis**, and its supporting mesodermal connective tissue, the **dermis**.
- (3) **Epidermis** constitutes the investing cellular membrane of the organisms. It is a stratified **squamous epithelium** which represents peculiar metabolic end product in the form of fibrous protein, **keratin**. The epidermis consists of the following layers :
  - (a) **Stratum corneum** : Its cells are a nucleate broad flat scales. These cells are the end product of the process of epidermal keratinization. Cells are bi-refringent containing disulphide linkages.
  - (b) **Stratum lucidum** : Next layer consists of flat cells without granules and having eleidin.
  - (c) **Stratum granulosum** : Transition from the stratum germinativum to the stratum corneum is marked by the stratum granulosum, a layer of flattened cells whose nuclei become pycnotic and whose cytoplasm contains refractory granules, the **keratohyaline granules**.
  - (d) **Stratum malpighii** : This is innermost layer, consisting of **germinal layer**. New cells are budded off from this layer **mitotically** and move upwards.
- (4) **Hairs** are characteristic of mammalian skin only. Each hair is an elongated structure consisting of **hair shaft**, **hair follicle**, and hair pin.

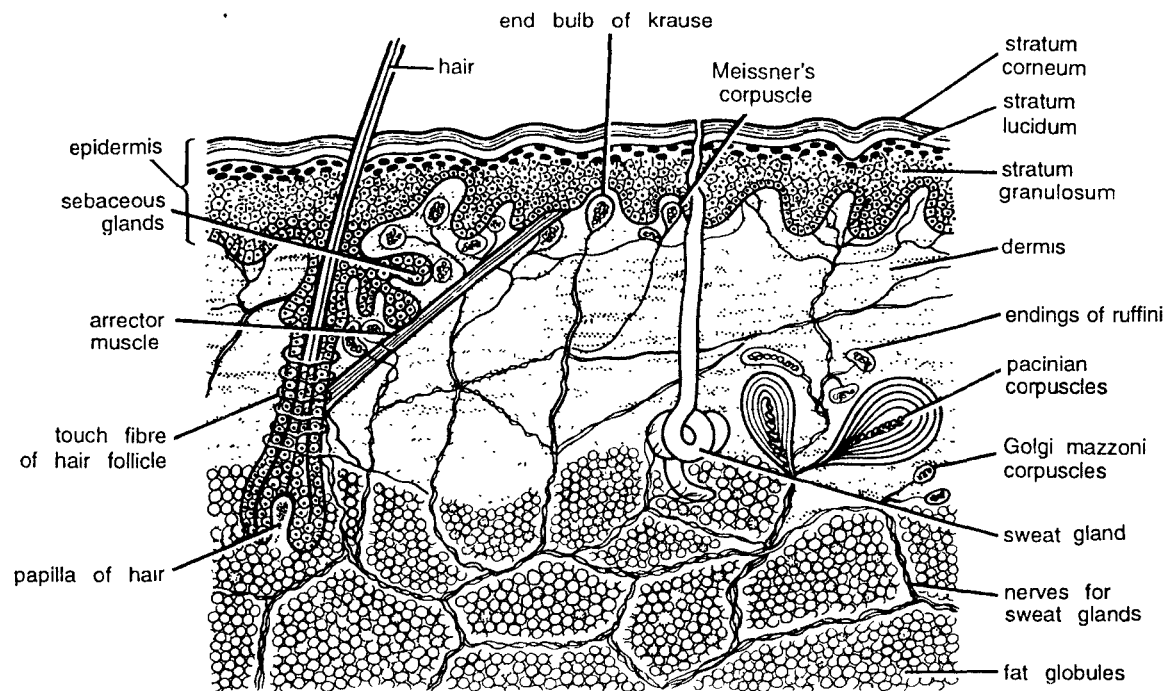

Fig. 51. Rabbit : V.S. of Skin.



- (5) Hair shaft projects obliquely on the body surface. Erector muscles move the hair involuntarily.
- (6) **Dermis** : Beneath epidermis is dermis. It is formed of areolar connective tissue. It originates from dermatome. It contains **sebaceous glands** and **sweat glands**.
- (7) Below dermis is a sub-cutaneous reticular layer, consisting of penniculus **adipose globules**.
- (8) **Golgi mazzoni corpuscles**, **Pacinian corpuscles** and endings of **ruffini** are also seen in the section.
- Special features** : Skin serves various functions such as—(i) **protective**, (ii) **defensive**, (iii) maintains shape, (iv) receives stimuli, (v) acts as insulators, (vi) prevents **loss of water** due to adipose tissue, (vii) **excretory** (sweat gland eliminates water and other waste products), (viii) **milk producing** (by mammary glands), etc.

**Identification** : Since section contains hair and above features, hence it is V.S. of **skin of mammal**.

## 52. Rabbit : T.S. Passing Through Cardiac Stomach

**Comments :**

**A. Under low magnification** : (7 X eye-piece; 4 X objective).

- (1) Stomach is an important, sac-like structure, functioning digestive and masticatory. It is composed of **serosa**, **muscle layer**, **sub-mucosa**, **muscularis mucosa**, and **mucosa**.

**B. Under high magnification** : (10 X eye-piece; 40 X objective).

- (2) **Serous coat** or serosa forms outer-most layer.
- (3) **Muscle layer** or muscular coat consists of outer thick longitudinal fibres, middle circular fibres and inner longitudinal and oblique fibres. Ganglionated nerve plexus is found between muscle layers.
- (4) **Longitudinal** muscles run longitudinally and form thick muscle layer. By their contraction, the stomach becomes shortened and the volume of its lumen is widened.
- (5) **Circular muscle** consists of circular fibers forming comparatively thinner layer than L.M.F. By the contraction of these muscles the stomach increases in size but its lumen is reduced.

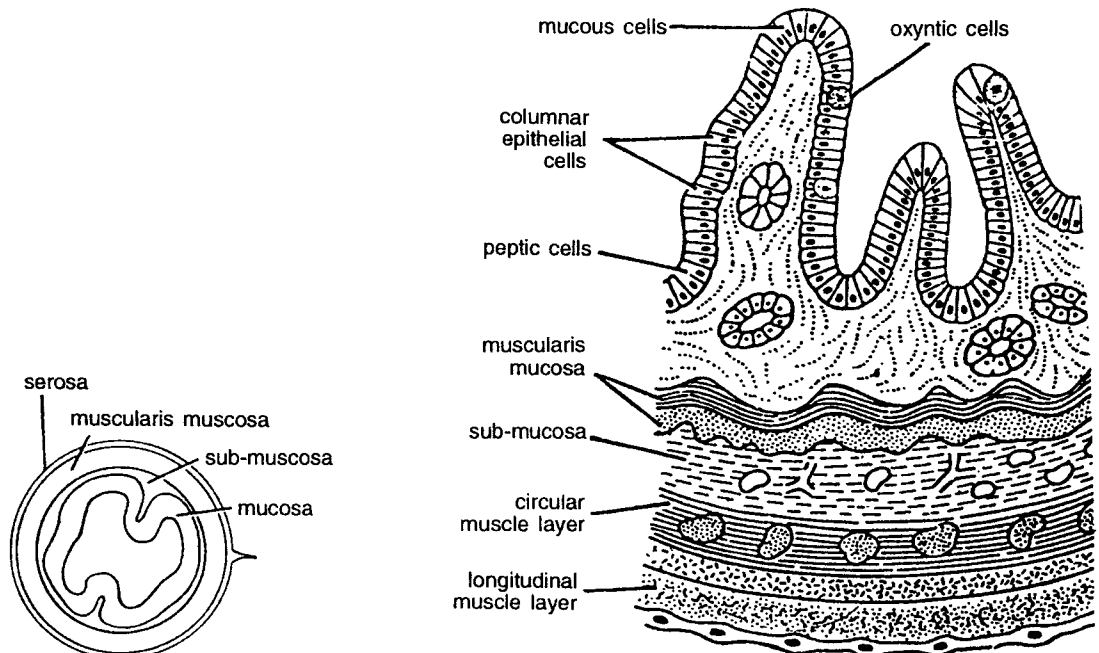

**Fig. 52.** Rabbit : **A.** T.S. passing through stomach under low magnification, **B.** T.S. of cardiac stomach under high magnification.

- (6) **Longitudinal** and **circular muscles** become thicker towards pylorus. The oblique fibres are best developed in cardiac stomach.
  - (7) **Sub-mucosa** is a loose areolar connective tissue present between circular muscle layer and muscularis mucosa.
  - (8) **Muscularis mucosa** is a thin layer consisting of **outer longitudinal** and **inner circular fibres**.
  - (9) **Mucosa** is thrown into villi. Mucosa is made up of **tall columnar epithelial cells**. Mucosa contains **peptic cells** secreting pepsin, **oxyntic cells** secreting HCl and **mucous cells** secreting mucous.
  - (10) Stomach produces gastrin, a hormone, which activates **gastric glands** to secrete digestive enzymes.
- Special features (functions) :** By alternate contraction and relaxation of stomach muscles, food is masticated and pushed forwards and digested. Pepsin breaks peptide bonds and converts proteins into derived proteins *i.e.*, peptones and proteoses. Lipase hydrolyses fats into glycerol and fatty acids.

**Identification :** Since it has thick longitudinal muscles and all above features, hence it is T.S. of **cardiac stomach of rabbit**.

### 53. Rabbit : T.S. Passing Through Ileum

**Comments :**

**A. Under low magnification :** (10 X eye-piece; 4 X objective).

- (1) The T.S. through ileum shows that it is composed of outer **serosa**, **muscular coat**, **sub-mucosa**, **muscularis mucosa** and **mucosa**.

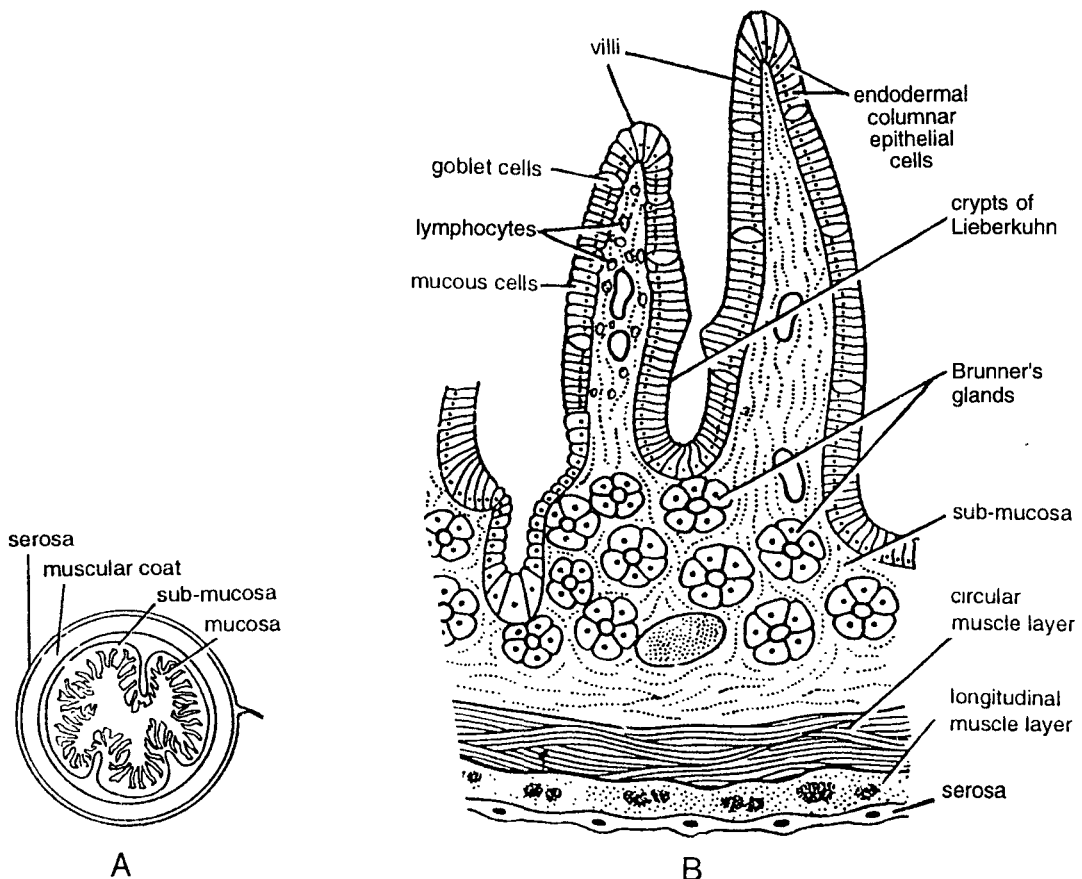

**Fig. 53.** Rabbit : A. T.S. passing through ileum under low magnification, B. T.S. passing through ileum under high magnification.

**B. Under high magnification :** (10 X eye-piece; 40 X objective).

- (2) Serosa forms outer thin layer covering containing squamous epithelial layer.
- (3) **Muscular** coat consists of **outer longitudinal** and **inner circular** fibres.
- (4) Longitudinal muscle layer is comparatively thinner. By their contraction intestinal tube is shortened but its lumen is widened.
- (5) Circular muscle layer is almost double in thickness than the L.M.L. On its (CML) contraction there is increase in the size of the intestine but decrease in the lumen.
- (6) **Sub-mucosa** is well developed and is composed of loose connective tissue.
- (7) Sub-mucosa is very thin layer consisting of outer longitudinal and inner circular muscle layer.
- (8) **Mucosa** is thrown into **villi** or folds composed of single-layered endodermal columnar epithelial cells. From the base of villi upto surface layer there are several tubular simple or branched glands called as **crypts of Lieberkuhn**. These glands are lined by epithelial cells containing **goblet cells**.
- (9) Above muscularis mucosa there are several nucleated rounded glands called as Brunner's glands. **Villi** are composed of tall simple columnar endodermal columnar epithelial cells or absorptive cells and rounded goblet cells. Several nuclei are seen. The inner substance of the villi contains connective tissue, lacteals and nuclei. Along with basal nuclei rounded **lymphocyte** cells are clearly seen.

**Special features (functions) :** Ileum receives three kinds of digestive enzymes – (a) pancreatic juice containing trypsin, amylase and lipase, (b) bile juice containing **bicarbonate**, **glycocholate** and **taurocholate**, and (c) succus entericus containing peptidase, lipase, invertase, maltase and lactase. These enzymes are secreted in response to two hormones secreted in duodenum : (i) **cholecystokinin** which stimulates liver to secrete bile juice, and (ii) **secretin** which stimulates pancreas to secrete pancreatic juice. In ileum food is converted into **amino acids**, **polypeptides**, **maltose**, **glycerols** and **fatty acids**.

**Identification :** Since villi contain Goblet cells and all above features, hence it is T.S. of **ileum (small intestine) of rabbit**.

## 54. Rabbit : T.S. Passing Through Liver

**Comments :**

- (1) Liver of rabbit is a five-lobed structure. T.S. passing through liver shows hepatic strands, bile ducts, blood vessels and central vein.
- (2) The liver is a solid **glandulo-reticular** organ made of **polyhedral** radiating column of cells called as laminae.
- (3) Bile canaliculi lie among the hepatic cells and connect in groups forming bile ductule or portal-tract consisting of **bile**, **duct hepatic artery** and **hepatic** vein.
- (4) Each **hepatic lobule** is pierced everywhere with a network of **sinusoid**.
- (5) Conspicuous cells occur at intervals on the walls of the sinuses. These are called as **stellate** or **Kupffer cells**. They are highly phagocytic and they ingest erythrocytes and other suspended particles. Kupffer cells could be best seen under high magnification presence of Kupffer cell indicates immune response.

**Special features (functions) :** (i) Liver is a very important organ for **metabolism** and has following functions, (ii) It secretes **bile juice** consisting of bile salts, **bile pigments** and **lecithin**, (iii) It stores **glycogen**, **inorganic** salts of iron, **copper** and **basophilic** ribo-nucleoprotein, (iv) **Glycogenesis** and **Glycogenolysis** take place in liver, (v) Liver produces **fibrinogen** and **prothrombin** which are essential components of blood clotting. It also produces **heparin**, an anticoagulant substance, (vi) Liver changes

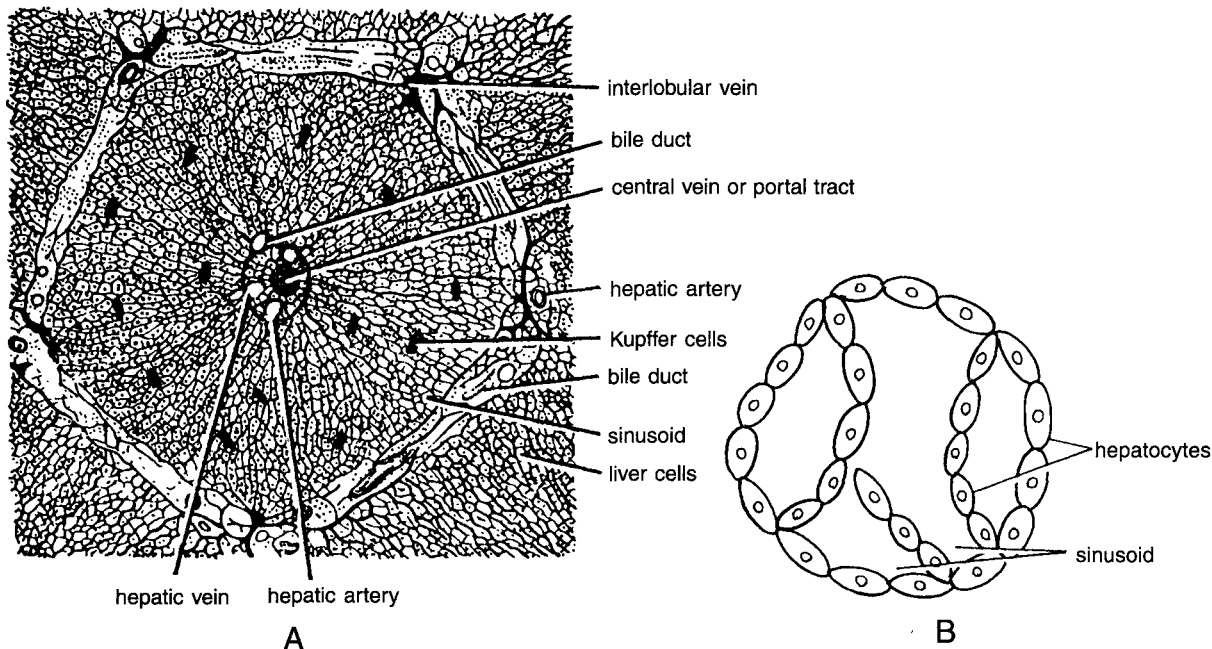

Fig. 54. Rabbit : A. T.S. passing through liver under low magnification, B. Few hepatocytes under high magnification.

ammonia into urea by **ornithine cycle**, (vii) It controls **oxidation** of sugar, (viii) Various enzymes are synthesized in liver, (ix) It also stores and synthesizes vitamins, (x) In embryonic condition it produces blood corpuscles.

**Identification :** Since the section shows radiating column of cells and above features, hence it is T.S. of **liver of rabbit**.

## 55. Rabbit : T.S. Passing Through Pancreas

**Comments :**

**A. Under low magnification :** (10 X eye-piece and 4 X objective).

- (1) Pancreas is a very important digestive gland. T.S. passing through it shows that it is composed of various **alveoli** or **pancreatic acini**. It is a compound tubulo-alveolar racemose gland consisting of both **exocrine** and **endocrine** parts.
- (2) The mammalian pancreas can be distinguished from that of frog in having distinct lobulations, **alveoli** or **pancreatic acini** and **islets of Langerhans**.
- (3) Each pancreatic lobe contains 10 to 20 secretory cells or acini which are nucleated. The central part has narrow to wide lumen. The pancreatic duct, large artery and vein are also seen in the section. Several cut blood vessels present in connective tissue.

**B. Under high magnification :** (10 X eye-piece; 40 X objective).

- (4) **Acini** and islets of Langerhans are very clearly seen. The wall of each acinus is made up of columnar or **pyramidal cells**. Each cell contains a central nucleus and coarse granules. Each acinus has wide lumen.
- (5) The region of islets of Langerhans reveals 3 or 4 kinds of cells- $\alpha$ ,  $\beta$  and undifferentiated cells.

**Special features (functions) :** Endocrine islets of Langerhans, in eosin-haematoxylin-stained sections, appear as rounded masses of cells with unstained cytoplasm and they contain 3 kinds of cells : (i) **Alpha cells**

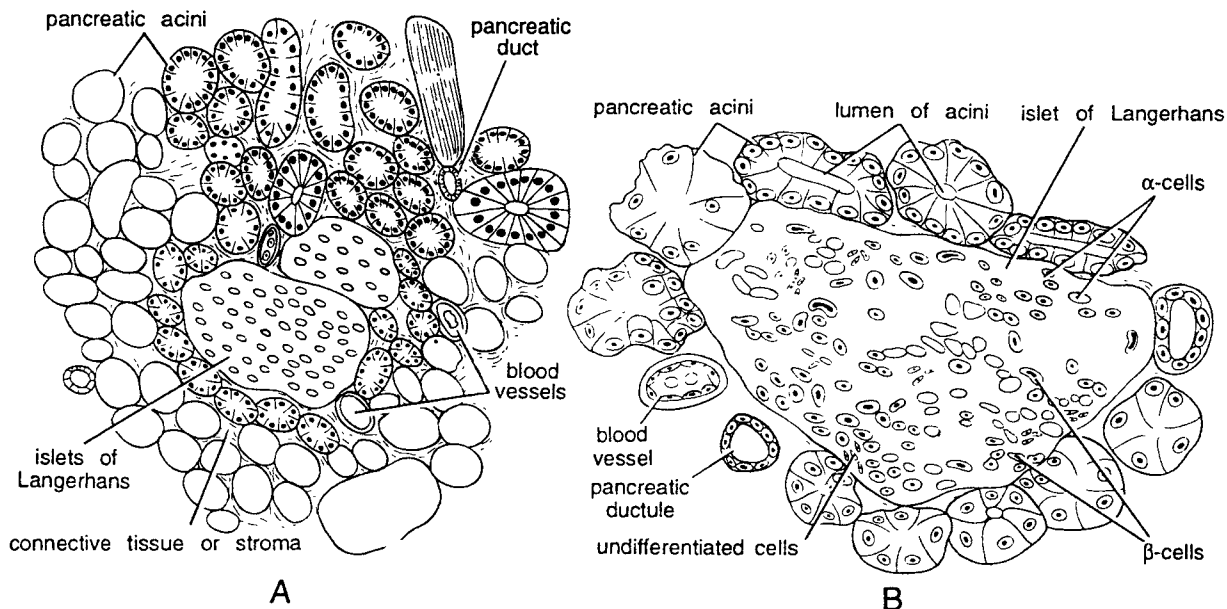

Fig. 55. Rabbit : A. T.S. passing through pancreas under low magnification, B. T.S. of pancreas under high magnification.

( $\alpha$ -cells) which secrete a **hormone** called as **glucagon**. It increases blood sugar level in the body and its deficiency causes **hypoglycemia**. (ii) **Beta cells** ( $\beta$ -cells) secrete another hormone, **insulin**, which plays an important role in **carbohydrate metabolism**. Its deficiency causes diabetes. It regulates blood sugar level, (iii) Some unknown undifferentiated cells of unknown function.

**Acini cells** secrete 3 kinds of pancreatic enzymes such as : (i) **Amylopsin** (amylase) which acts on **starch** and **glycogen** and changes them into **maltose**; (ii) **Tripsinogen** (trypsin) which acts on **peptones** and **proteoses** to change them into **aminoacids**; and (iii) **Lipase** which hydrolyses **fats** into **fatty acids** and **glycerols**.

**Identification** : Since the section contains acini and above features, hence it is T.S. of **pancreas of rabbit**.

## 56. Rabbit : T.S. Passing Through Spleen

### Comments :

**A. Under low magnification** : (10 X eye-piece; 4 X objective).

- (1) Spleen is the largest **lymphoid** gland.
- (2) It is dark brown in colour and composed of muscular and fibrous coat, **fibrous trabeculae**, **red pulp**, **white pulp** and is richly vascularised.
- (3) Capsule sends bands or trabeculae, which form a network in the substance of the gland.
- (4) In the interstices of the framework lies a soft pulpy substance, called as spleen **pulp** which may be **red** or **white**.
- (5) **Red pulp** forming the bulk gives red colour to spleen.
- (6) Section also contains blood corpuscles, **malpighian corpuscles**, **blood capillaries** venous sinuses and nerves.

**B. Under high magnification** : (10 X eye-piece; 40 X objective).

- (7) A portion of the spleen under high magnification shows clear distinction between **red** and **white pulp**.
- (8) Other structures seen are **penicilli of white pulp** and venous sinuses.

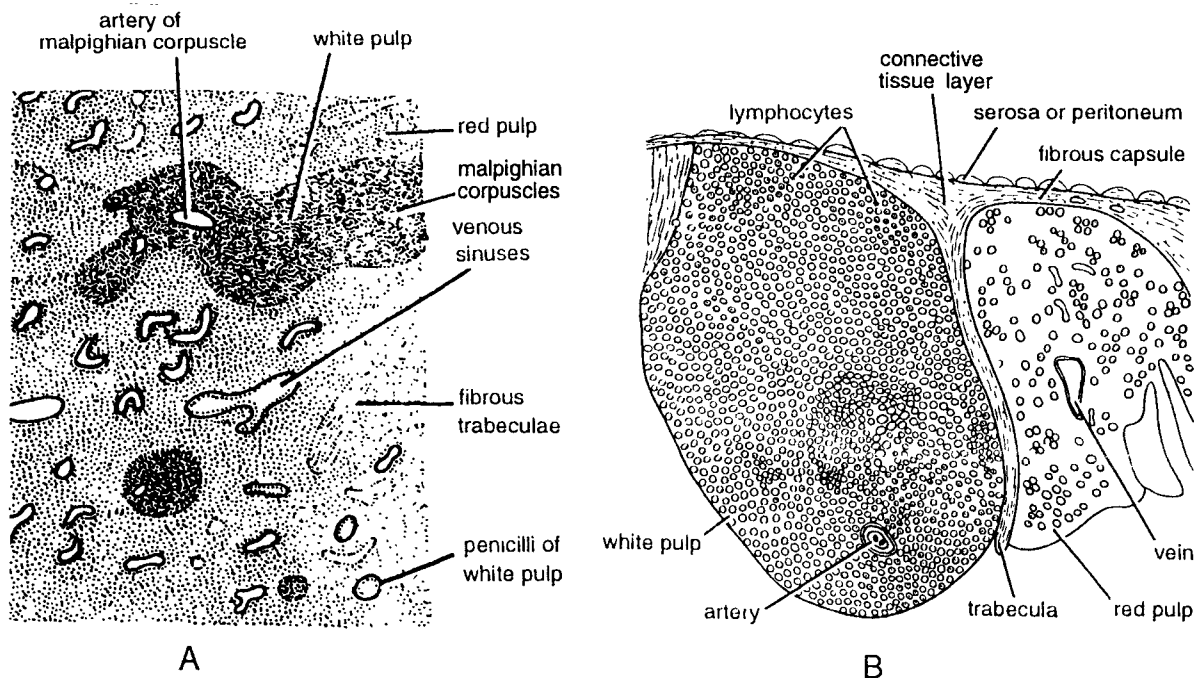

Fig. 56. Rabbit : A. T.S. passing through spleen under low magnification, B. T.S. of spleen under high magnification.

(9) **White pulp**, contains dense concentration of lymphocytes and looks darker while nuclei of **red pulp** are scattered. Indistinct reticular and phagocytic cells are also present.

**Special features (functions)** : Spleen has following functions – (i) Red and white pulp contain resident macrophages, T-lymphocytes, platelets and B-lymphocytes. It also contains plasmocytes secreting antibodies, (ii) It **stores** and **synthesizes leucocytes**, (iii) It contains **macrophages** which destroy old erythrocytes. (iv) In embryonic condition it produces erythrocytes but after birth leucocytes are produced.

**Identification** : Since the section contains red pulp, white pulp and all above features, hence it is T.S. of spleen of rabbit.

## 57. Rabbit : T.S. Passing Through Thyroid Gland

**Comments :**

**A. Under low magnification** : (10 X eye-piece; 4 X objective).

(1) It is the most familiar endocrine gland, consisting of right and left lobes connected across to the ventral side of trachea by isthmus.

(2) **Thyroid gland** comprises of a framework of connective tissue, enclosing numerous rounded or **oval follicles** or vesicles of different sizes and covered by capsule.

(3) Histologically it consists of a number of rounded **thyroid follicles** of various sizes, separated by one another by **connective tissue** strands.

(4) Thyroid is richly supplied with blood vessels and nerves. It is innervated from the **sympathetic nerves**.

(5) Thyroid secretes **thyroxin** ( $C_{15}H_{11}O_4N_4$ ) which contains an amino acid and 65% of iodine.

**B. Under high magnification** : (10 X eye-piece; 40 X objective).

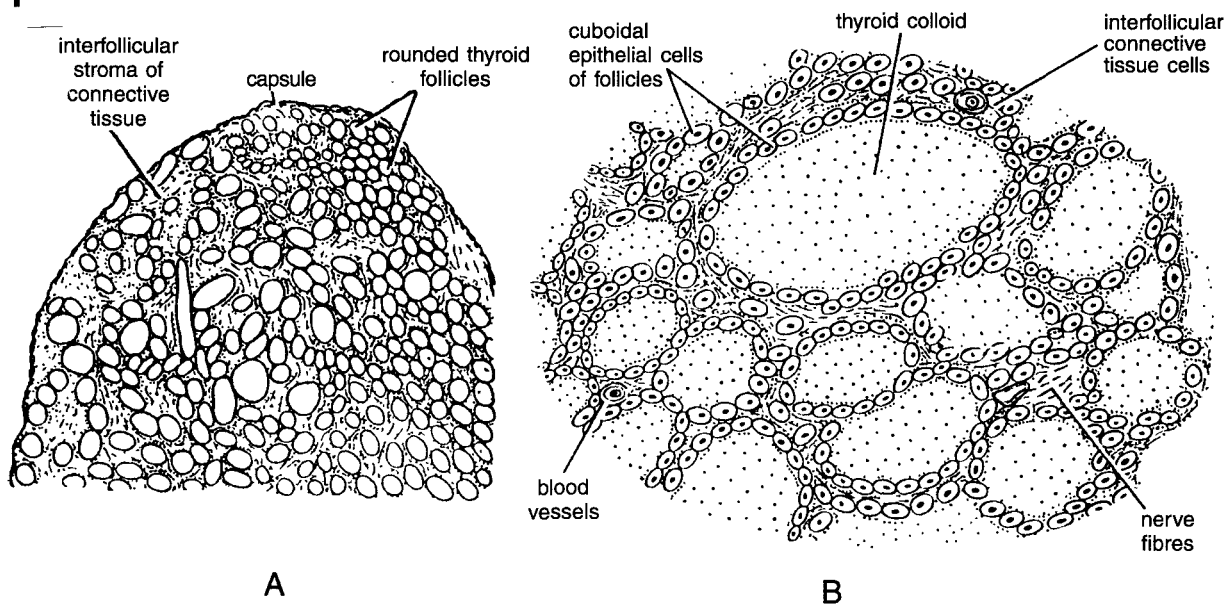

Fig. 57. Rabbit : A. T.S. passing through thyroid under low magnification, B. T.S. of thyroid under high magnification.

- (6) The **thyroid** is composed of **follicular** and **interfollicular** zones. Follicles are surrounded by single layered cuboidal epithelial cells. Lumen of each follicle, contains a viscous liquid called as **thyroid colloid**.
- (7) Interfollicular zone contains nerves, blood vessels and large number of nuclei : nerves, blood vessels and large number of nuclei.

**Special features (functions) : Thyroxin** controls entire metabolism. Its deficiency causes lowered metabolism.

**Hyperthyroidism** results in protrusion of **eye-balls**. Removal of thyroid from the frog tadpole stops metamorphosis. Thyroid gland is controlled by **TSH** (thyroid stimulating hormone) from pituitary.

**Identification** : Since the section shows rounded follicles and all above features, hence it is T.S. of **thyroid gland of rabbit**.

## 58. Rabbit : T.S. Passing Through Parathyroid Gland

### Comments :

- (1) Two **parathyroid** glands follicles are always found embedded in the substance of thyroid or found on each side of the thyroid gland.
- (2) Each parathyroid is enclosed within a **capsule**.
- (3) Each parathyroid is a glandular organ consisting of **columns of epithelial cells** and **blood vessels**.
- (4) The gland contains **chief cells**, **colloid** or **oxyphil cells**, separated by the connective tissue.
- (5) Parathyroid produces a hormone called as **parathormone**, which is devoid of iodine.
- (6) Removal of parathyroid causes **tetany** or **death**.
- (7) Numerous sinusoid blood channels run between the columns.
- (8) Parathyroid gland develops as epithelial outgrowth from the third and fourth branchial clefts of the embryo.

**Special features (functions) :** The secretion of parathyroid gland **controls calcium** and **phosphate**

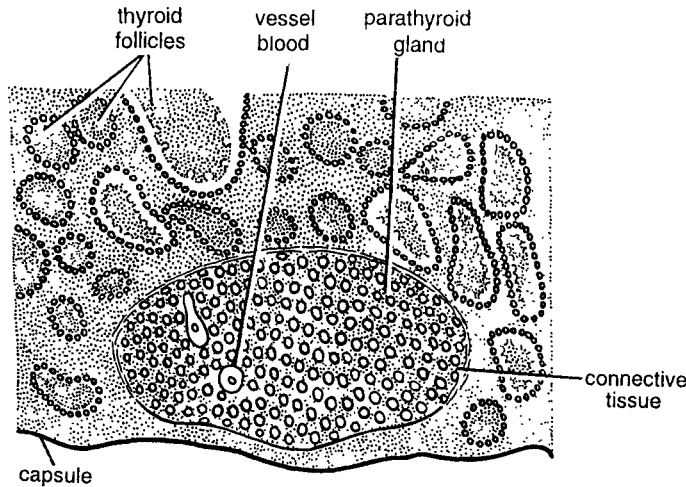

Fig. 58. Rabbit : T.S. passing through parathyroid gland.

concentrations in the blood plasma and it also controls their metabolism in the body.

**Identification :** Since the section contains column of cells and all above features, hence it is T.S. of parathyroid gland of rabbit.

## 59. Rabbit : T.S. Passing Through Adrenal Gland

### Comments :

- (1) **Adrenal glands** lie at the anterior end of kidneys and are two in number.
- (2) T.S. passing through the adrenal gland shows that it is composed of outer vertically striated, yellow coloured **cortex** and inner soft, highly vascular and dark brown **medulla**.
- (3) The entire gland is covered by **fibrous capsule**, which sends septa into the cortex and divides it into 4 zones : (i) **Zona glomerulosa**. This zone is found below the capsule. It comprises of columnar cells. This zone controls the mineral and water balance of the body and also fat and carbohydrate absorption. Active hormone is **deoxycorticosterone** which is not under pituitary control, (ii) **Zona fasciculata**. This zone consists of compressed cells which secrete **corticosterone** to control carbohydrate metabolism. This hormone also causes disintegration of lymphocytes and release of their antibodies, (iii) **Zona reticularis**. Next to medulla, this zone consists of pigmented reticular cells. This zone secretes sex hormones.
- (4) Medulla has irregularly disposed cells.
- (5) It contains elastic fibres and sinusoids (large blood spaces).
- (6) Medulla cells have granular cytoplasm which take dark stain with osmic vapour.
- (7) In some medulla cells are chromoffin bodies or paraganglia.
- (8) Cortex has mesodermal origin and medulla neuroectodermal, and have abundant blood supply.

**Special features (functions) :** Adrenal gland secretes important hormones both from medullary and cortical zones. The medullary hormones are **Epinephrine (Adrenaline)** and **Norepinephrine**. Epinephrine is hypoglycemic hormone, promotes **glycogenolysis** and increases blood pressure. The cortical region secretes corticoids which promote **gluconeogenesis** and marked effect on **protein metabolism**.



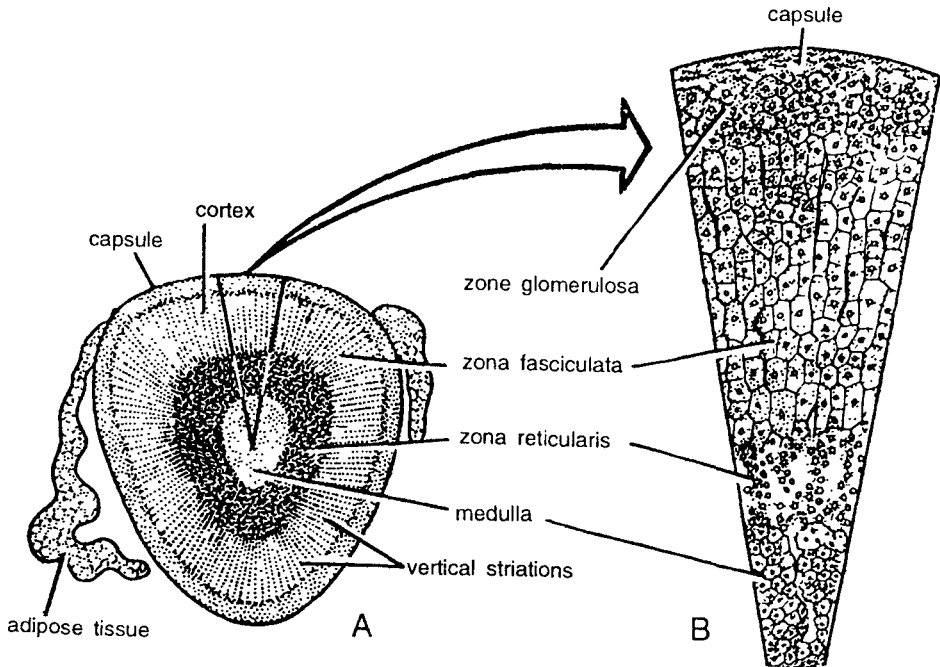

Fig. 59. Rabbit : A. T.S. passing through adrenal gland under low magnification, (10 X eye-piece; 4 X objective), B. T.S. of adrenal gland under high magnification (10 X eye-piece; 40 X objective).

**Identification :** Since the section shows 4-zones and all above features, hence it is T.S. adrenal gland of rabbit.

## 60. Rabbit : T.S. Passing Through Lung

### Comments :

**Under high magnification :** (10 X eye-piece; 40 X objective).

- (1) T.S. through lungs shows bronchioles, alveoli, blood vessels, lymphatic vessels and nerves.
- (2) Bronchi are lined by ciliated epithelium resting with basement membrane.
- (3) Ciliated columnar epithelial cells are surrounded by circular muscle fibres. Next to muscles are loose fibron spongy tissues containing bronchioles mucous glands and alveoli.
- (4) Alveoli contain 2 winds of (i) small cubical thick cells and (ii) very thin nucleated cells.
- (5) Bronchioles have lumen.
- (6) Several cut pulmonary veins and arteries are observed.

**Special features (functions) :** Lung is a very important respiratory organ, where atmospheric  $O_2$  combines with haemoglobin to form

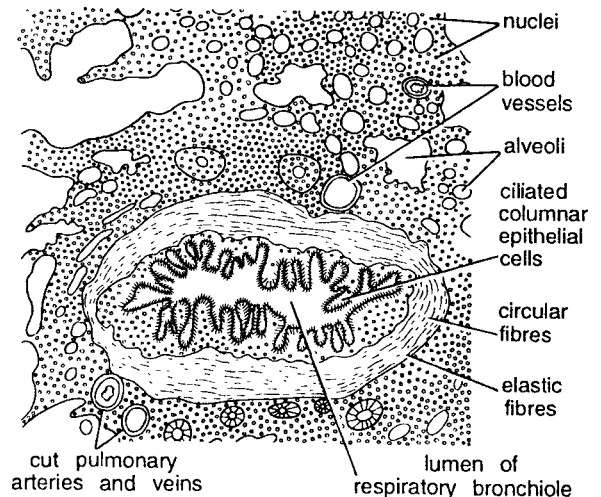

Fig. 60. Rabbit : T.S. passing through lung.

**oxyhaemoglobin** in blood capillaries. From the lungs oxyhaemoglobin is transported to body for cellular respiration. CO<sub>2</sub> is also expelled from the body through the lungs.

**Identification** : Since the section contains alveoli and all above features, hence it is T.S. lung of rabbit.

## 61. Rabbit : L.S. Passing Through Kidney

### Comments :

**A. Under low magnification** : (10 X eye-piece; 4 X objective).

- (1) **Kidney is metanephric**, compact, bean-shaped, retro-peritoneal, compound, tubular gland, attached to dorsal body wall. Covered by **retroperitoneal** covering and **fibroin capsule**.
- (2) Sagittal section of the kidney reveals two distinct portions—(i) **cortex**, and (ii) **medulla**. Between these two zones is undefined boundary zone characterized by large blood vessels.
- (3) Cortex has several rounded **Bowman's capsules**. Medulla is subdivided into conical portions called **pyramids**.
- (4) Cortex and medulla are entirely composed of uriniferous tubules, which have straight direction in the medulla and contorted arrangement in the cortex. Renal artery renal vein and ureter enter at the hilum.
- (5) Groups of straight tubules pass from the medulla through the thickness of the cortex forming medullary rays.
- (6) Between medullary rays are the deep cortical downgrowths, called as **renal column of Bertini**.

**B. Under high magnification** : (15 X eye-piece; 4 X objective).

- (7) Uriniferous tubules are lined with large granular ciliated epithelial cells and begin in the cortical part of the organ in dilation as **Bowman's capsules**, which enclose convoluted tufts of blood capillaries called **glomerulus** and several nuclei.
- (8) **Capsule** is lined by flattened epithelium. **Glomerulus** is formed by branches of afferent and efferent vessels. Tubule leaves the capsule by neck and it forms proximal convoluted ascending limb, descending limb and **loop of Henle**. Blood vessels are also seen in the section.

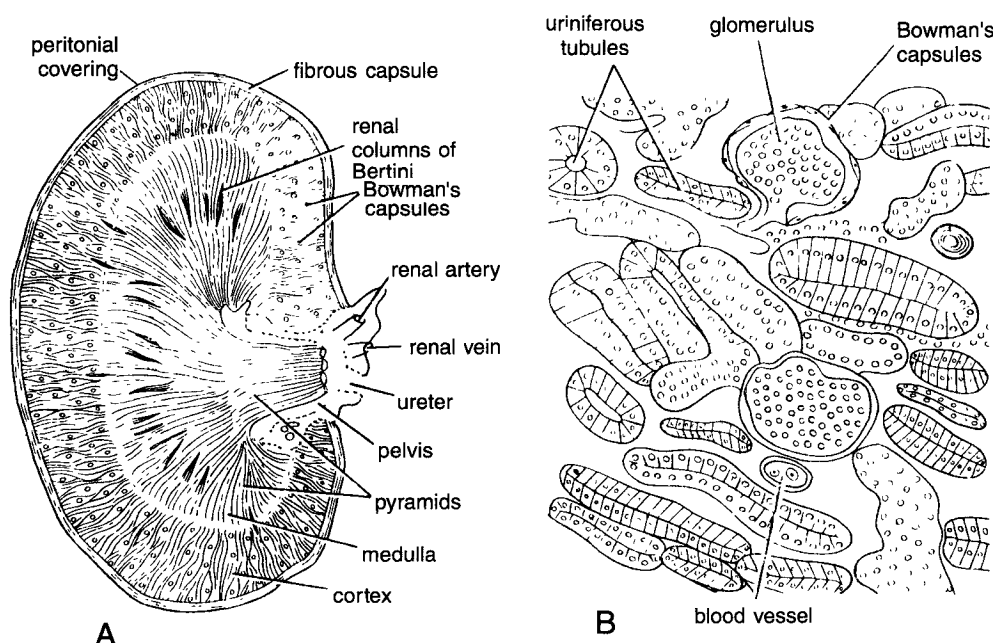

**Fig. 61.** Rabbit : A. L.S. passing through kidney showing cortex and medulla under low magnification, B. A portion of kidney under high magnification.

**Special features (functions).** Kidney is the important **excretory** organ. It **filters** from the **blood water, urea, uric acid and phosphates.**

**Identification :** Since section contains cortex medulla and all above features, hence it is V.S. **kidney of rabbit.**

## 62. Rabbit : T.S. Passing Through Testis

**Comments :**

**A. Under low magnification :** (10 X eye-piece; 4 X objective).

- (1) There is a pair of smooth, oval-shaped **testes**, each enclosed in a thin envelope, called as **tunica albuginea (A).**
- (2) Histologically each **testis** is internally divided into a number of lobules with occasional internal communications and separated by connective tissue.
- (3) Glandular substance of the testis is wholly made up of convoluted **seminiferous tubules.** Large **number** of cut seminiferous tubules are seen with varying diameter.
- (4) Section shows **tunica albuginea, cells, sperms, seminiferous tubules** and **lumen of seminiferous tubules (B).**
- (5) Interstitial cells which produce a hormone, called as **testosterone.** Which is responsible for the development of male **secondary sexual character.**

**B. Under high magnification :** (10 X eye-piece; 40 X objective).

- (6) **Testis** is covered by serosa and a fibrous coat or tunica albuginea.
- (7) At the interjunction of two seminiferous tubules, connective tissue, interstitial cells vacuoles and blood vessels are seen.
- (8) In the seminiferous tubules are some nutritive Sertoli cells.
- (9) Seminiferous tubules appear rounded or oval in section. Each tubule is surrounded by a thin basement membrane lined by germinal epithelium.
- (10) From basement membrane to inwards there are several kinds of cells : (i) **Spermatogonia** lie along periphery of tubule and appear closely packed together, (ii) **Primary spermatocytes** — They have the largest cells and large nuclei, (iii) **Secondary spermatocytes** — Smaller cells with deeply stained

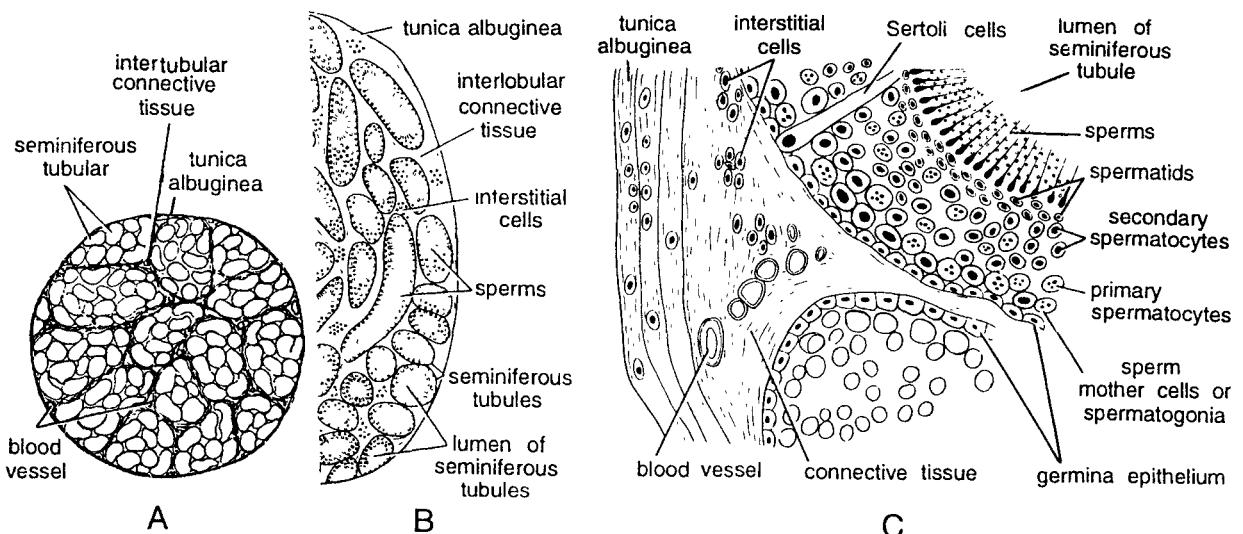

**Fig. 62.** Rabbit : **A.** T.S. passing through testis under low magnification, **B.** T.S. of testis, **C.** T.S. of testis under high magnification.

nuclei, (iv) **Spermatids** — Small clusters of cells with condensed nuclei, (v) **Spermatozoa** or sperms lie in the cavity of the tubule.

- (11) Sperm has head and tail.
- (12) The nucleus of the sperm lies in the head which is pointed as the acrosome.
- (13) Outer covering tunica albuginea interstitial cells and blood vessels etc. are seen in the section T.S. **testis of rabbit.**

**Identification :** Since the section contains sperms and all above features, hence it is T.S. **testis of rabbit.**

### 63. Rabbit : T.S. Passing Through Ovary

**Comments :**

**A. Under low magnification :** (10 X eye-piece; 4 X objective).

- (1) Outer most layer is of **peritoneum** which has **cupical** cells.
- (2) Just beneath peritoneum is **germinal epithelium** bounded by connective tissue called as **tunica albuginea**.
- (3) Germinal epithelium gives rise to **oogonia**, **developing follicles** and **Graafian follicle**.
- (4) Section shows young follicles and mature Graafian follicles and **corpus luteum**.
- (5) Interior of the section shows connective tissues, interstitial cells and blood vessels.

**B. Under high magnification :** (10 X eye-piece; 4 X objective).

- (6) Detailed structure of Graafian follicle is seen under high magnification. Follicle is surrounded by connective tissue or **stroma**.
- (7) Fully **mature oocyte** is surrounded by a thick transparent layer called **Zona pellucida** surrounded by another layer corona radiata.
- (8) Corona radiata is surrounded by mass of cells called as **discus proligerous** or **cumulus**.
- (9) Corona radiata is surrounded by **liquor folliculi** and then by membrane granulosa. Thick membrane granulosa is covered by thick layer called as **theca folliculi**.

**Identification :** Since the section contains Graafian follicle and all above features, hence it is T.S. **of ovary of rabbit.**

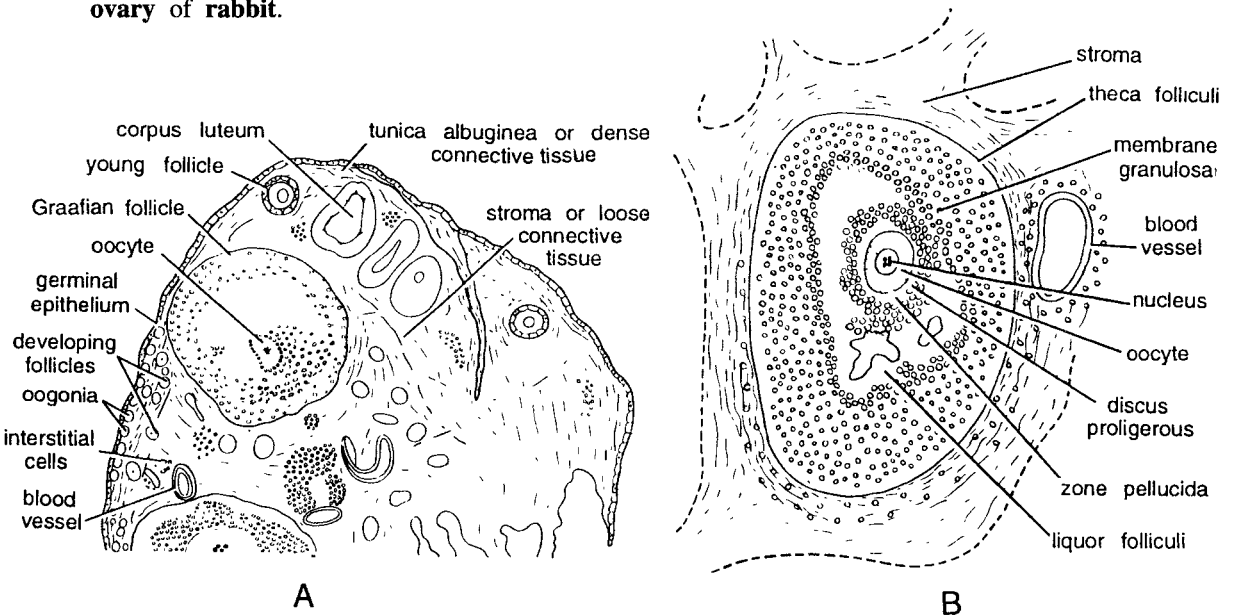

**Fig. 63.** Rabbit : **A.** T.S. passing through ovary under low magnification, **B.** T.S. of Graafian follicle under high magnification.

## 64. Rabbit : T.S. Passing Through Bone

### Comments :

- (1) Bone in T.S. is covered by thin layer called as **periosteum**.
- (2) Below periosteum is **endosteum**.
- (3) Space in endosteum is filled by matrix which contains **periosteal lamellae** and interstitial lamellae.
- (4) Interstitial lamellae contains **Haversian system**. Haversian system is composed of central **Haversian canal** surrounded by concentric rings of **lacunae** and **canaliculi**.
- (5) Each Haversian contains blood vessels, lymph vessels and nerves.

**Identification :** Since the above section contains Haversian canal and above features, hence it is T.S. of **bone of rabbit**.

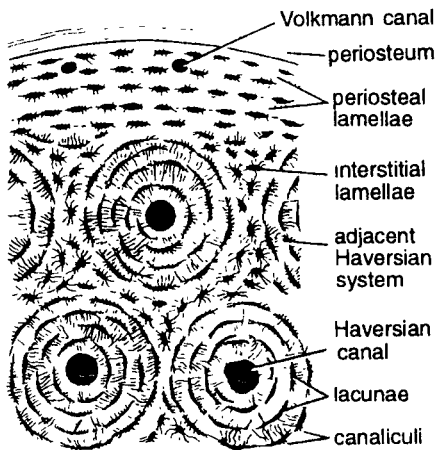

Fig. 64. Rabbit : T.S. passing through bone.

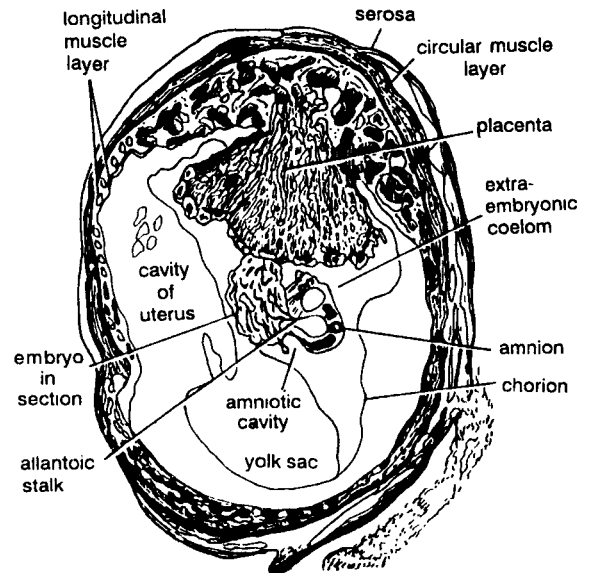

Fig. 65. Rabbit : T.S. passing through placenta.

## 65. Rabbit : T.S. Passing Through Placenta

### Comments :

- (1) Structure of placenta shows outer **serosa**, **longitudinal** and **circular muscle** fibres, **uterine crypts**.
- (2) In placenta **foetal villi** and uterine crypts are seen.
- (3) In section embryonic part is broad.
- (4) Chorion, amnion, amniotic cavity, yolk sac, allantoic stalk, embryo in section and cavity of uterus seen.
- (5) It is discoidal placenta of haemochorial type. In blood vessels of chorionic epithelium and foetal villi maternal blood directly flows.

**Identification :** Since the section contains embryo and all above features, hence it is of **placenta of rabbit**.

## 66. Rabbit : T.S. Passing Through Spinal Cord

### Comments :

- (1) Just after emergence from the foramen magnum, medulla continues as **spinal cord**.
- (2) T. S. of spinal cord shows that it is covered by three membranes **outer** piameter, **middle** arachnoide space and **inner** durameter.
- (3) Entire nervous tissue is divided into outer **white matter** and inner **grey matter**.
- (4) White matter and grey matter are made up of **nerve cells** and **nerve fibres** respectively.
- (5) **Grey matter** is H-shaped or **butterfly shaped** and is perforated by a central canal.
- (6) Grey matter projects dorsolaterally and ventrolaterally as paired dorsal and ventral horns respectively for attachment of nerve roots.
- (7) Dorsal and ventral horns penetrate deep into white matter as dorsal and ventral septums respectively.
- (8) Other structures seen are motor neurons and blood vessels.
- (9) Spinal cord gives spinal nerves which control reflex activities and also conduct impulses to and pro from brain.

**Identification :** Since the grey matter is H-shaped a butterfly shaped and shows above features, hence it is T.S. of **spinal cord of rabbit**.

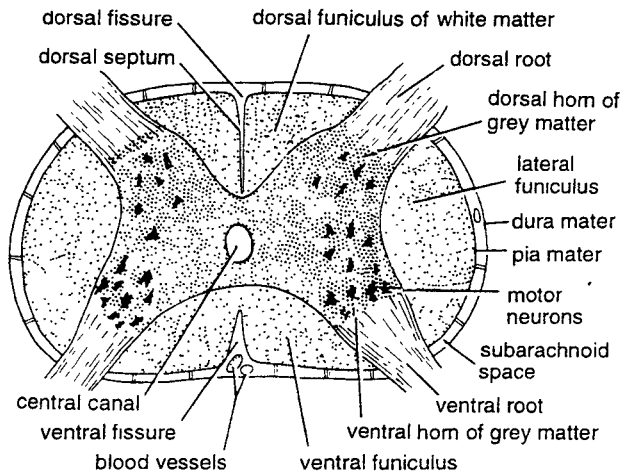

**Fig. 66.** Rabbit : T.S. passing through spinal cord.

## H. STUDY OF PHOTOGRAPHS OF ANIMAL TISSUES

### 67. Simple Cuboidal Epithelium

Simple cuboidal epithelial cells can be studied in a T. S. passing through the kidney. Prepare paraffin sections of kidney through **microtomy**. Stain the sections with haematoxylin, eosin and mount in DPX. Let sections become dry. Study the sections under the microscope and take microphotograph (Fig. 67).

### Comments :

- (1) Cuboidal epithelial cells are distinctly seen in collecting tubules.
- (2) Cuboidal cells are compactly placed.

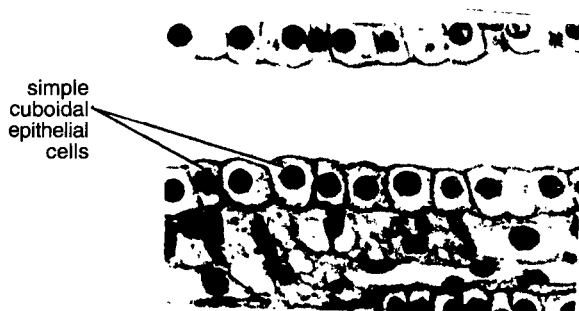

**Fig. 67.** Microphotograph. Rat T.S. of kidney. Simple cuboidal epithelium.

## 68. Simple Columnar Epithelial Cells

Simple columnar epithelial cells could be studied by paraffin sections of T. S. intestine of frog, rabbit or earthworm. Take a frog, anaesthetize, dissect and take small portion of intestine 2 to 4 cm. Fix it in 10% formalin for 24 hours. Wash the intestine in running tap water. Process the intestine for paraffin sectioning by microtomy. Stain sections in Haematoxylin-Eosin. Dehydrate, dealcoholize and mount in DPX. Study under microscope in high magnification. Take microphotograph (Fig. 68).

### Comments :

- (1) Internal lining of the intestine is made up of tall **simple columnar epithelial cells**.
- (2) These cells are **nucleated, ciliated** and are derived from **endoderm**.
- (3) Columnar epithelial cells of intestine are absorptive cells through which **amino acid, monosaccharides and fatty acids** are **absorbed** by blood besides other nutrients.



Fig. 68. Microphotograph. Rat T.S. of intestine. Simple columnar epithelium.

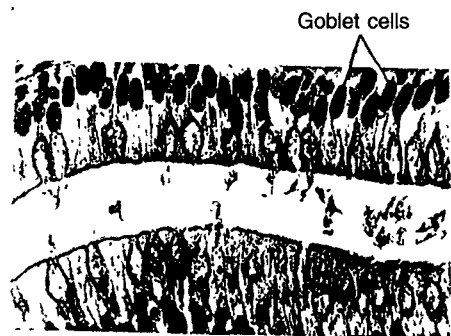

Fig. 69. Microphotograph. T.S. of intestine showing Goblet cells.

## 69. Goblet Cells

Goblet cells are also studied from the T.S. intestine of frog or rabbit. Process microtomy sections as in case of columnar epithelial cells. Study under microscope. Take microphotograph.

### Comments :

- (1) Goblet cells are found towards lumen of the intestine along columnar epithelial cells.
- (2) Goblet cells are rounded **nucleated** and **aggregated** together.
- (3) Goblet cells secrete mucous.
- (4) Nuclei of Goblet cells stain deep with haematoxylin.

## 70. Adipose Tissue

Take fat bodies from frog. Stain them in Sudan IV solution. Dissolve 0.1 gm of Sudan IV in 50 ml of acetone and add equal volume of 70% alcohol. Stains fat bodies in Sudan IV solution, dehydrate and mount in DPX. Take microphotographs. Study under microscope.

### Comments :

- (1) Cells of adipose tissues are **rounded** and **polygonal**.
- (2) Fat droplets aggregate and found fat bodies or **adipose tissues**.
- (3) Cells of adipose tissues have thin layer of cytoplasm and nucleus is displaced towards one side.

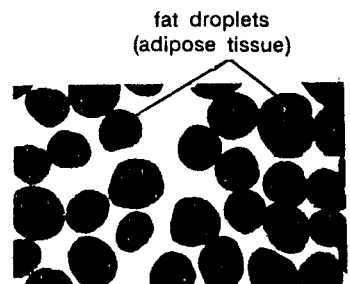

Fig. 70. Microphotograph. Frog. Adipose tissue.

## 71. Reticular Tissues

Reticular tissues can be studied by making a mount of **lymph vessels** or by making paraffin sections of spleen of frog. Take a frog, anaesthetize, dissect and take few lymph vessels. Fix in 10% formalin for 30 minutes, wash the tissues and stain in borax-carmin, dehydrate and mount in DPX. Study under microscope. Take microphotograph. Reticular tissues can also be studied in a T.S. of spleen of frog. Take a frog dissect, take out spleen, fix in 10% formalin, wash, prepare paraffin section (T.S.) of spleen, stain with haematoxylin. Eosin and mount in DPX. Study under microscope. Take microphotograph.

### Comments :

- (1) Reticular tissue consists of a **network of cells**.
- (2) Cells contain stiff interconnected cytoplasmic fibrils.
- (3) Spaces between reticular cells are filled with other kinds of cells, blood cells and nerve cells etc.



**Fig. 71.** Microphotograph. Rat. Lymph vessels showing Reticular tissue.

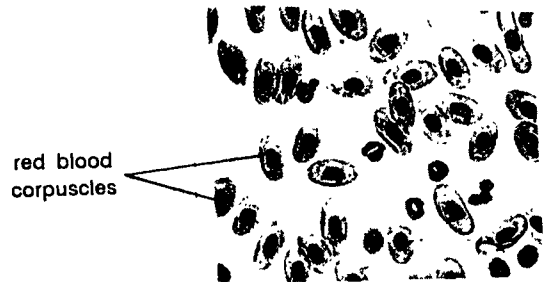

**Fig. 72.** Microphotograph. Frog. Blood smear showing blood corpuscles.

## 72. Blood Smear of Frog

Prepare a thin blood film. Take a freshly killed frog. Dissect frog and collect blood by cardiac puncture. Take a clean slide. Put a pin head size blood on a clean slide at a distance of about half an inch from its right edge. Hold another slide by right hand and apply over drop of blood at an angle of 45°, lower the angle to 30° and push the spreader slide forward till the blood is exhausted. Let the film dry. Keep the slide in 6" petridish. Flood the slide by Leishman stain for 30 seconds. Wash the slide and let the slide dry. Examine the slide under microscope.

### Comments :

- (1) Large number of nucleated biconvex **erythrocytes** are seen.
- (2) **Lymphocytes** with large nucleus rounded in shape present.
- (3) Monocytes and **polymorphonuclear leucocytes** are also present.

## 73. Blood Smear of Rabbit

Prepare thin blood film of Albino rat as in case of frog.

### Comments :

- (1) RBC or **erythrocytes** are rounded and non-nucleated.

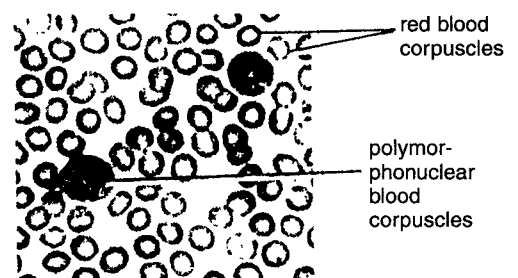

**Fig. 73.** Microphotograph. Rabbit. Blood smear showing blood corpuscles.



- (2) Other corpuscles are WBC (White Blood Corpuscles), **monocytes**, **lymphocytes**, and **polymorphonuclear leucocytes**.

### 74. Frog : T.S. Passing Through the Testis

For studying different types of cells testis is also very suitable organ. Take a frog, anesthetize it by chloroform. Dissect and take the two testes. Fix them in 10% formalin solution for 24 hours. Wash them with distilled water for 4.6 hours to remove formalin. Make paraffin sections through the process of microtomy stain the section with haematoxylin and eosin. Dehydrate, dealcoholize and mount in DPX. Study under microscope and also take microphotography of a portion of T.S. testes.

#### Comments :

- (1) T.S. through **testis** reveals that it is composed of outer **peritoneal layer**, **seminiferous tubules**, **interstitial cells** and blood vessels. Section is more or less rounded in outline.
- (2) Each seminiferous tubule contains **germinal epithelium** or **sperm** mother cell, which gives rise to **primary spermatocytes**, **secondary spermatocytes**, **spermatids** and **sperms** or **spermatozoa**.
- (3) Sertoli cells are absent.
- (4) Blood vessels and interstitial cells are seen in the photograph.

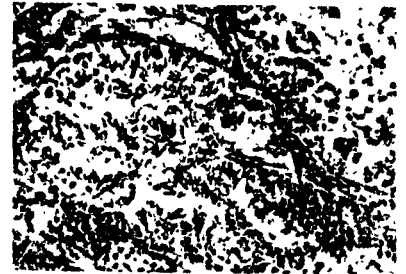

Fig. 74. Microphotograph. Frog. T.S. of Testis.

### 75. Frog : T.S. Through Ovary

In transverse section of ovary, ova could be seen in various stages of development. Make a permanent slide of ovary of frog by cutting paraffin sections through microtomy. Take a frog, anaesthetize it. Cut open abdomen and take out ovaries. Fix ovary in 10% **formalin** for 24 hours. Wash the ovary with running tap water for 4 to 6 hours to completely remove the **formalin**. Process ovary for paraffin sections stain with haematoxylin and eosin. Mount in DPX study the sections under microscope and take microphotographs.

#### Comments :

- (1) Various ova are seen in developing stage.
- (2) Primary **oogonium** gives rise to primary oocyte.
- (3) Primary oocyte changes into **secondary oocyte**.
- (4) Each ovum has centrally placed **nucleus** **egg shell** and granular cytoplasm.

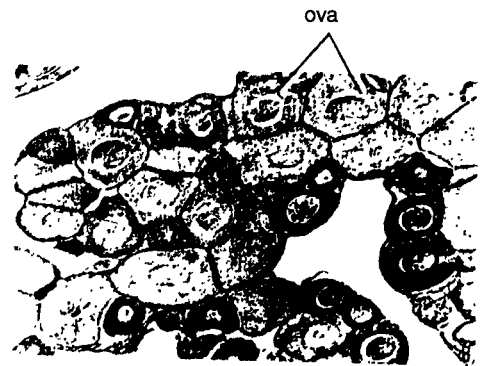

Fig. 75. Microphotograph. Frog. T.S. of ovary.

# Study of Embryology Slides

# 9

## SPERMATOGENESIS

**Spermatogenesis** can be studied through histological preparation of tissues (testis) or by **squash technique** or **heat dry Giemsa** technique. For histological studies, testis of Albino rat is taken out after chloroforming rat. After fixing testis in 10% formaline, its sections are cut through **microtomy process**. Stain sections in **haematoxylin** and **eosin**, dehydrate, clear in xylol and mount in DPX. Study various stages under the microscope. For spermatogenesis, various changes undertaken in chromosomes, slide can be made by squash technique and heat dry Giemsa technique. Study the slides under microscope for various stages as under.

### 1. Rabbit : T. S. Passing Through Testis and Spermatogenesis

#### Comments :

- (1) T. S. Testis shows various stages of spermatogenesis.
- (2) Serosa is a hard cellular layer called on **tunica albuginea**.
- (3) Each **seminiferous** tubule is covered by a thin basement membrane and lined germinal epithelium.
- (4) Germinal epithelium has **sperm mother cell** which undergoes **mitotic division** to give rise to **diploid spermatogonia**.
- (5) Each spermatogonium gives rise to two **primary spermatocytes**. Each primary spermatocyte gives rise to two **secondary spermatocyte** which are haploid after reduction division.
- (6) Each secondary spermatocyte undergoes second meiotic division or mitotic division and gives rise to two **spermatids**. These spermatids again divide and give rise to four spermatozoa.
- (7) In the first reduction division, **prophase-I, leptotene, zygotene, pachytene, diplotene** and diakinesis occurs followed by anaphase-I and telophase-I. Because of above stages this is longest stage.

**Identification** : Since the section has spermatids, spermatozoa and above feature, hence it is T. S. of **testis of rabbit**.

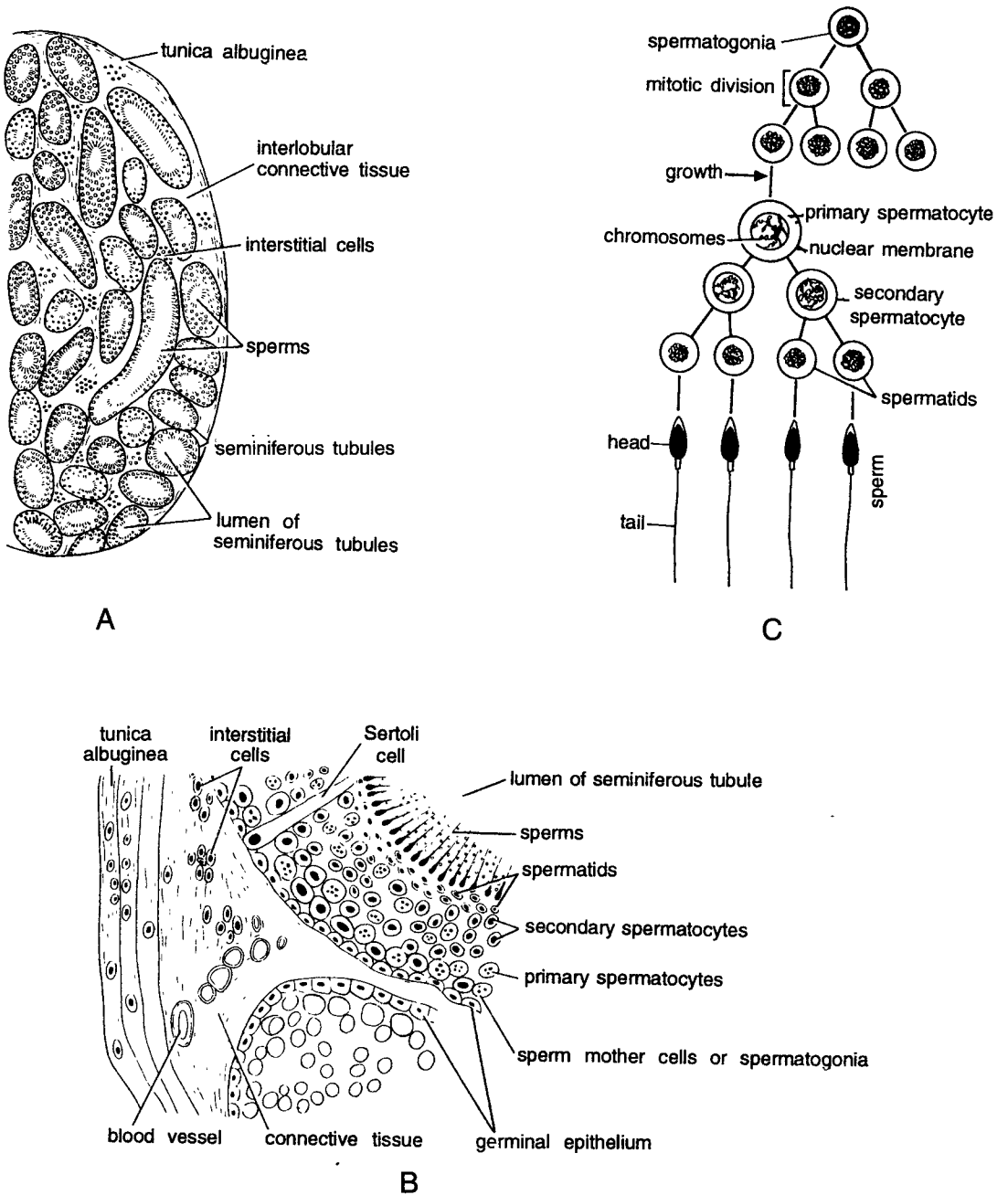

**Fig. 1.** Rabbit : T.S. passing through testis and spermatogenesis. **A.** Low magnification. **B.** High magnification, **C.** Stages of spermatogenesis.

## OOGENESIS

Development of fully mature oocyte is called as oogenesis. In males one spermatogonium gives rise to 4-spermatozoa. In female one oogonial mother cell gives rise to four oocytes. Out of four oocytes, three of them degenerate and only one develops into mature ovum. Ovum is always larger because it has to carry bulk of development and it is ovum which is transformed into adult individual either male or female. Oogenesis can be studied by **histological** studies of tissue or by **squash technique** or by **heat dry Giemsa** method. Take a albino rat, chloroform it, dissected and take out **ovaries** and fix is 10% formalin. Cut sections by microtomy process. Stain sections in Haematoxylin and eosin. Dehydrate, clear and mount is DPX. Study under high and low magnification.

### 2. Rabbit : T. S. Passing Through Ovary and Oogenesis

#### Comments :

- (1) T. S. through ovary shows **serosa**, oogonial mother cells and oogonial cells (Fig. 2).
- (2) Serosa is outer most layer lined by **oogonial mother cells**.
- (3) Oogonial mother cells divide mitotically forming oogonial cells which develop into **oocytes**.
- (4) Oogonial cells pass through growth phase and maturation phase.
- (5) Older oocytes contains yolk platelets, DNA, RNA, E.R. (endoplasmic reticulum), ribosomes, Golgi body and cortical granules.
- (6) Appearance of two polar bodies of maturation indicates ovum.
- (7) In ovary other structures seen are **tunica albuginea stroma**, blood vessels, **interstitial cells**, **oogenic**, developing **follicles**, **germinal epithelium**, **oocytes**, **Graafian follicles**, **young follicles** and **corpus luteum**.

**Identification :** Since the section has Graafian follicle and above features, hence it is T.S. of **ovary of rabbit**.

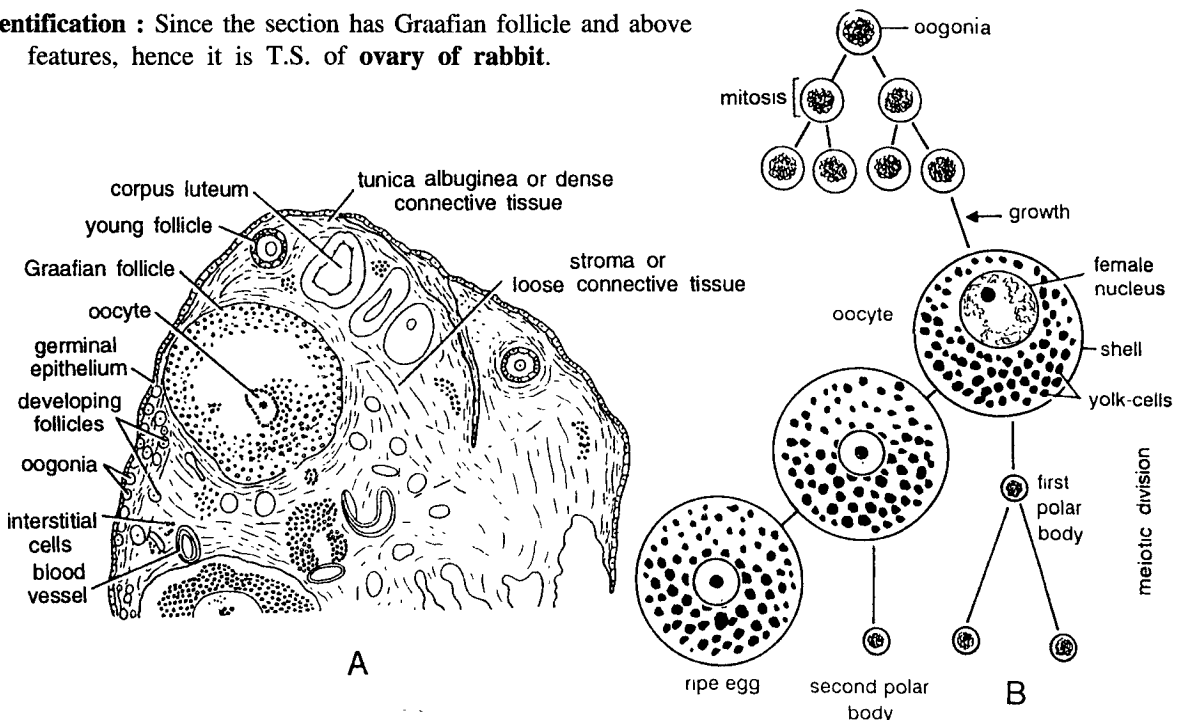

Fig. 2. Rabbit : T.S. passing through ovary and oogenesis. A. Low magnification, B. Stages of oogenesis.

### 3. Study of Fertilization Through A Model Diagram

**Comments :**

- (1) In the model diagram a **haploid ovum** fuses with a **haploid spermatozoa** to give genetically **diploid zygote** (Fig. 3).
- (2) In both internal and external fertilization on one egg one or several active sperm reach but only one fertilizes the ovum.
- (3) Sperm contains tail, mitochondria, nucleus and acrosome sperm first recognizes the plasmamembrane of female nucleus and then penetrates. Only head enters the egg after encountering cortical granule.
- (4) Plasma membrane of sperm fuses with egg plasma membrane through agglutination.
- (5) Fertilizin and antifertilizin help in fertilization and head nucleus fuses with female nucleus forming **zygote**.

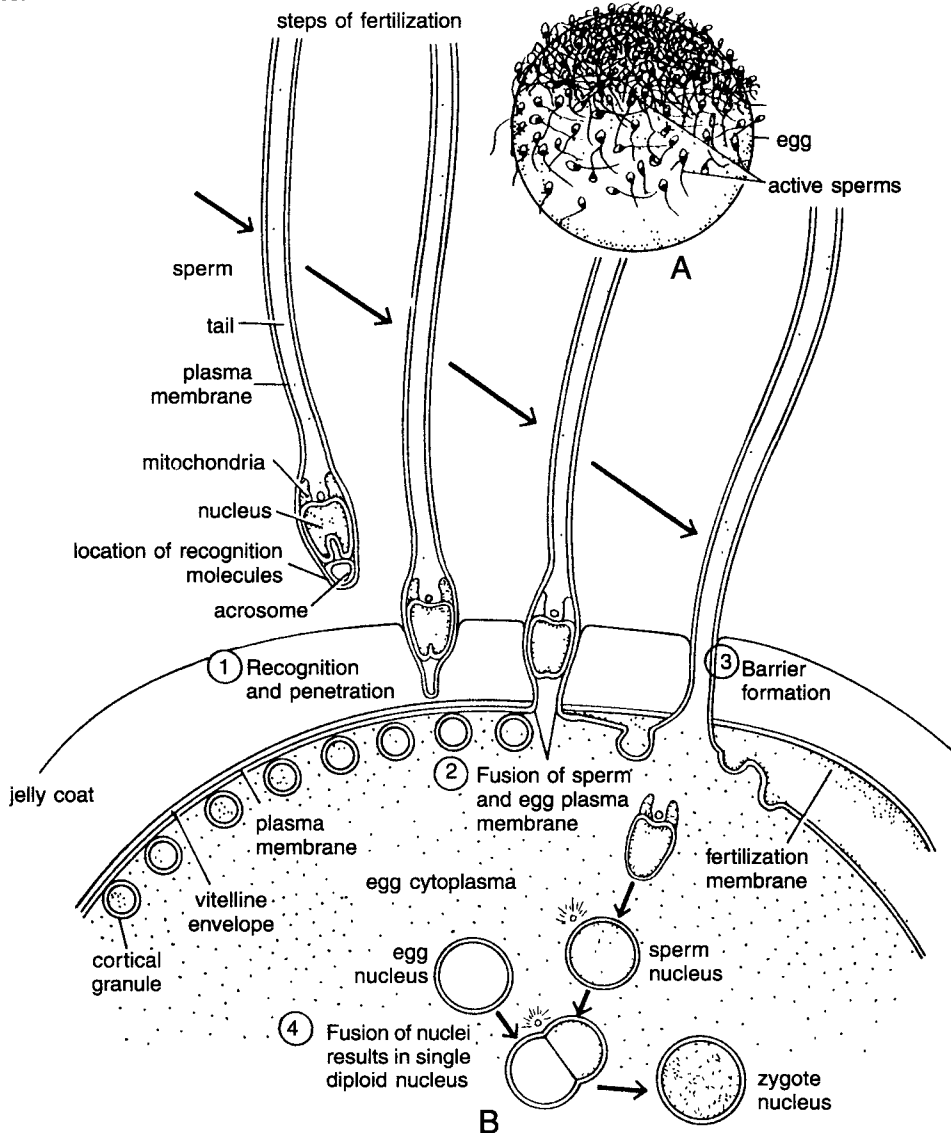

Fig. 3. Different stages of fertilization-Model.

- (6) Penetration of sperm head is helped by proteolytic **hyaluronidase enzyme**.
- (7) After fertilization and formation of zygote no other sperm enters as by chemical reaction a barrier membrane is formed to prevent entry of any other sperm.
- (8) In diagram **cortical granules**, **vitelline envelope**, fusion of sperm and egg plasma membrane fertilization membrane, sperm nucleus and diploid zygote is seen.

**Identification :** Since the figure has zygote and above features, hence it depicts model for **fertilization**.

## DEVELOPMENT OF FROG

### 4. Frog : Structure of Ovum

**Comments :**

- (1) The **ovum** is rounded in shape and covered by albumen layer, chorion and vitelline membrane.
- (2) It measures 1.6 mm in diameter (Fig. 4).
- (3) One half of the **zygote** is **pigmented black** called animal hemisphere and the remainder is almost **white**.
- (4) **Vitelline** membrane swells up on the exposure to water. The interspaces contain minute plants, which give oxygen by their manufacture of food to the embryo.
- (5) Cytoplasm of the egg contains **yolk**, **nucleus**, polar body and vitelline membrane.
- (6) Blackish brown pigment **granules of melanin** assemble at future animal hemisphere forming a superficial pigmented layer.
- (7) Centre of the pigmented area is the **animal pole** and the opposite end is the **vegetal pole**.
- (8) Soon after fertilization the embryo rotates within the **vitelline membrane** so that the animal hemisphere is the uppermost.

**Identification :** Since the egg contains pigmented hemisphere towards animal pole, hence it is **ovum of frog**.

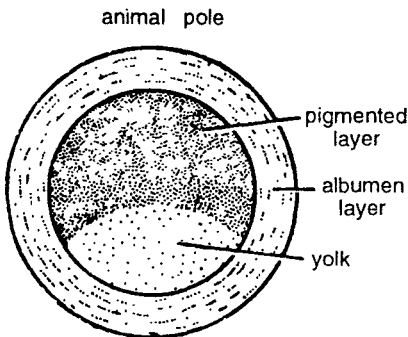

Fig. 4. Frog : Structure of ovum.

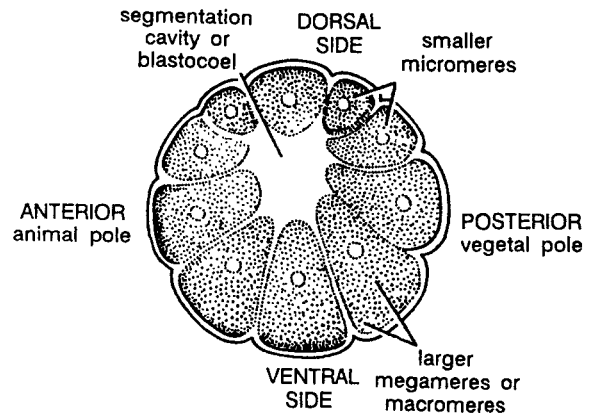

Fig. 5. Frog : V.S. through blastula.

### 5. Frog : V.S. Passing Through Blastula

**Comments :**

- (1) Egg cleaves and forms blastula at 8-cell stage (Fig. 5).
- (2) Blastula contains a **blastocoel** cavity surrounded by unequal blastomeres.
- (3) **Smaller** blastomeres are called as **micromeres**, found in upper half and contain dark pigments.

- (4) Larger blastomeres are called as **macromeres**, found in more than lower half and laden with yolk.  
 (5) Lower side or **vegetal hemisphere** is composed of large yolky megameres. Because of their large size the blastocoel is excentric lying towards the **animal pole**.

**Identification :** Since the egg contains blastocoel and above features hence it is V. S. through **blastula of frog**.

## 6. Frog : V.S. Passing Through Gastrula

### Comments :

- (1) **Gastrulation** is a rearrangement of cells already present in the blastula. This completely reorganizes embryo. During this process three **germinal layers** are formed (Fig. 6).  
 (2) Future prospective organ forming cells are organized at their proper places at gastrula stage.  
 (3) Gastrulation occurs by **epiboly**, **blastopore involution** and **invagination**. During this process mesodermal and notochordal cells migrate inside, forming roof of **archenteron**.  
 (4) Gastrula has three germinal layers-namely, **ectoderm**, **endoderm** and **mesoderm** from which various organs are derived. Section shows dorsal side, ventral side, animal pole and vegetal pole.  
 (5) Other structures seen in section are dorsal lip of **blastopore**, **yolk plug**, **ventral lip of blastopore**, **notochordal cells** and **neural plate**. The **blastocoel** is reduced due to the development of archenteron.  
 (6) **Ectoderm** gives rise to epidermis, cutaneous glands, **nervous system**, **eye parts** and **lining of mouth cavity and cloaca**.  
 (7) **Endoderm** forms lining of alimentary canal, liver, pancreas, lung and urinary bladder.  
 (8) **Mesoderm** gives rise to musculature, connective tissue, vascular system, genital organs, excretory organs, skeleton and notochord.

**Identification :** Since the section shows 3 germinal layers and above features, hence it is V. S. through **gastrula of frog**.

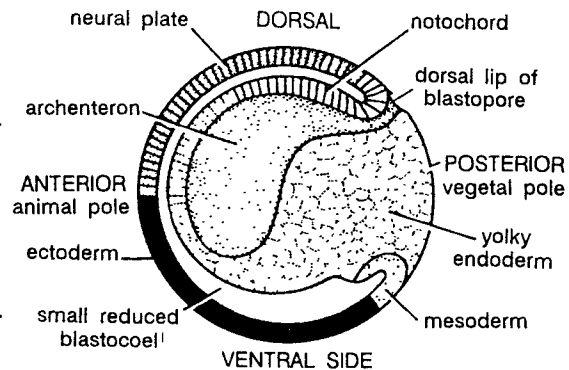

Fig. 6. Frog : V.S. through gastrula.

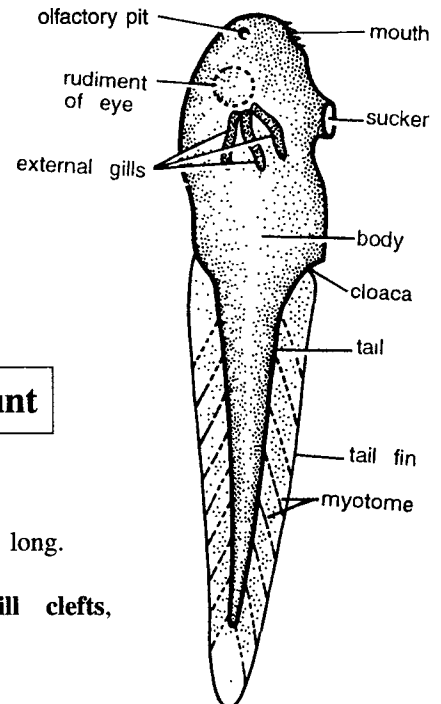

Fig. 7. Frog : Whole mount-Tadpole larva.

## 7. Frog : Tadpole Larva : Whole Mount

### Comments :

- (1) Egg hatches into **tadpole larva** within 48 hours (Fig. 7).  
 (2) It is whitish with dark pigment granules and 5 to 6.5 mm long.  
 (3) Larva is differentiated into **body** and **tail** with **tail fin**.  
 (4) Larva contains **rudiments of eyes**, **olfactory pit**, **gill clefts**, **stomodaeum**, **cloaca** and **myotomes**.  
 (5) **Mouth** contains horny jaws or **horny teeth**.  
 (6) Larva feeds on vegetation. Intestine is coiled.

- (7) There are three pairs of external **feathery gills** which act as functional respiratory organs.  
 (8) Tadpole larva **metamorphoses** into adult.

**Identification :** Since the larva contains 3 pairs of gills and above features, hence it is whole mount of **tadpole larva of frog**.

## 8. Frog : Tadpole T.S. Passing Through Eyes

### Comments :

- (1) Eyes are most conspicuous and portuberant structures and they begin to develop very early. Eyes develop from **optic vesicles**, which originate from a pair of diverticula given from **thalamencephalon** on each side. Below forebrain is trabecula.  
 (2) Section shows a pair of **large eyes** on the sides of forebrain. Each eye is composed of **eye muscles**, **lens** and sensory layer of **retina**.  
 (3) Other structures seen in section are **jaw muscles**, **large pharynx**, **palatoquadrate bar**, **Meckels cartilage**, **hyoid arch**, **connective tissue** and **epidermis**.

**Identification :** Since the section contains eye, hence it is T. S. **tadpole of frog through eyes**.

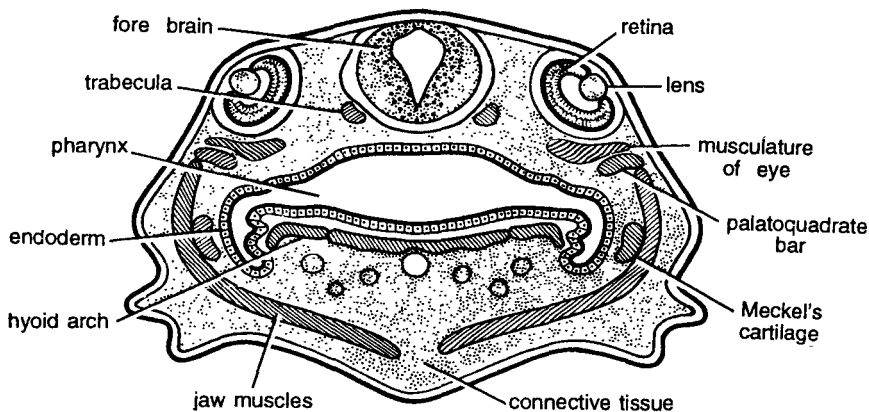

Fig. 8. Frog : T.S. of tadpole through eyes.

## 9. Frog : Early Tadpole T.S. Passing Through Ears

### Comments :

- (1) Ears develop as a pair of **auditory pits** from epiblast on sides of **hindbrain** (Fig. 9).  
 (2) Auditory pits become **vesicle like** called auditory vesicle and enclose the **middle ear**. **Semicircular canals** develop as outgrowths from the wall of auditory vesicles.  
 (3) Auditory vesicles develop at early tadpole stage and found on dorsal side of the section. Between two auditory vesicles is situated the **medulla oblongata**, enclosing **IV ventricle**. Beneath medulla oblongata the notochord is present.  
 (4) Lower portion of the section contains large **pharynx**, **laryngeal chamber**, **branchial arches** pericardial cavity and **pericardium**, enclosing developing **auricle** and **ventricle**.  
 (5) Other structures seen are first, second, third and fourth branchial arches, epidermis of operculum, news and ectoderm.

**Identification :** Since the section contains auditory vesicle and above features hence it is T.S. through **ear of early tadpole of frog**.



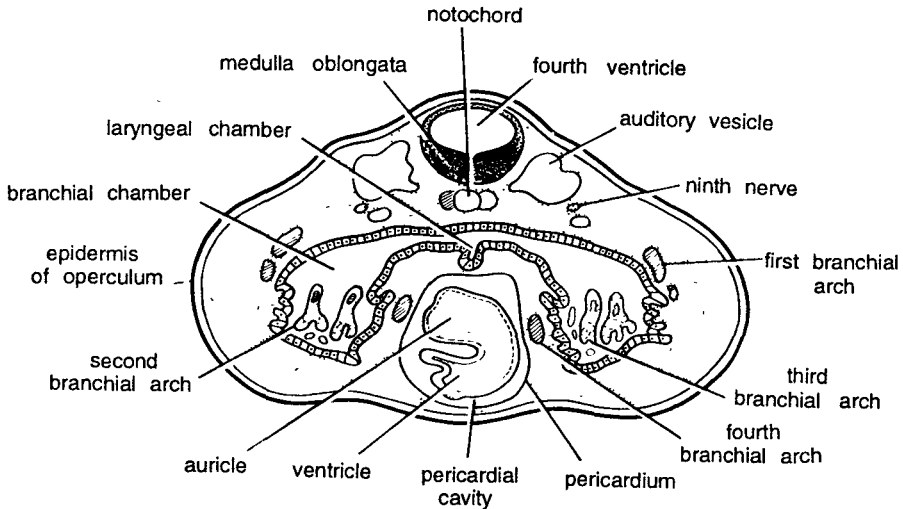

Fig. 9. Frog : T.S. of tadpole through ears.

## DEVELOPMENT OF CHICK

### 10. Chick Embryo : Whole Mount of 4 Hours of Incubation

**Comments :**

- (1) Four hours of incubation of the egg shows differentiation of the blastodisk into **area pellucida** and **area opaca**. Egg has cephalic end and caudal end (Fig. 10).
- (2) One quadrant of area pellucida becomes thickened, which marks the future caudal end of embryo.
- (3) After 7 to 8 hours, the thickening becomes more elongated and represents start of **primitive streak**.

**Identification :** Since embryo shows beginning of primitive streak, hence it is **chick embryo** whole mount **4 hours of incubation**.

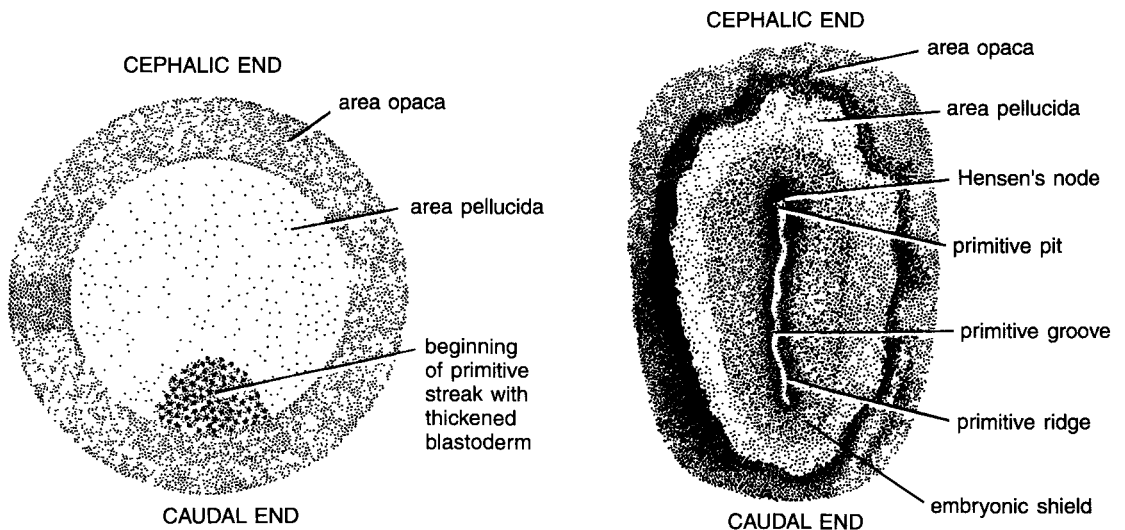

Fig. 10. Chick embryo : Whole mount. 4 hours of incubation.

Fig. 11. Chick embryo : Whole mount. 16 hours of incubation.

## 11. Chick Embryo : Whole Mount of 16 Hours of Incubation

### Comments :

- (1) By 16 hours of incubation the primitive streak becomes so distinct that embryos are characterized as being in **primitive streak stage** (Fig. 11).
- (2) In fixed and stained slide, w.m. primitive streak is composed of **central furrow**, called as **primitive groove** lined by thickened **primitive ridges** and ending in primitive pit.
- (3) At the cephalic end of the primitive streak, closely-packed cells form thickened area, called as **Hensen's node**. Part of area pellucida adjacent to the primitive streak shows increased thickness and forms embryonic area or **embryonic shield**.
- (4) Area pellucida assumes **elliptical shape**.
- (5) Elongated **primitive streak** represents long axis of future embryonic body.
- (6) Caudal and cephalic ends are demarcated by Hensen's node and end of primitive streak respectively.

**Identification :** Since it has primitive streak, hence it is whole mount of **chick embryo** after **16 hours of incubation**.

## 12. Chick Embryo : L.S. of 17 Hours of Incubation

### Comments :

- (1) L.S. through 17 hours embryo represents the stage shortly after primitive streak formation and it also marks the beginning of **morphogenetic movement** of cells to form **notochord**.
- (2) The section shows **ectoderm**, **Hensen's node**, **primitive pit**, **primitive groove**, **notochord** and **primitive gut** and endoderm.
- (3) The **mesoderm** extends on either side between **ectoderm**.

**Identification :** Since the section shows primitive pit and above features, hence it is L. S. of **chick embryo** of **17 hours of incubation**.

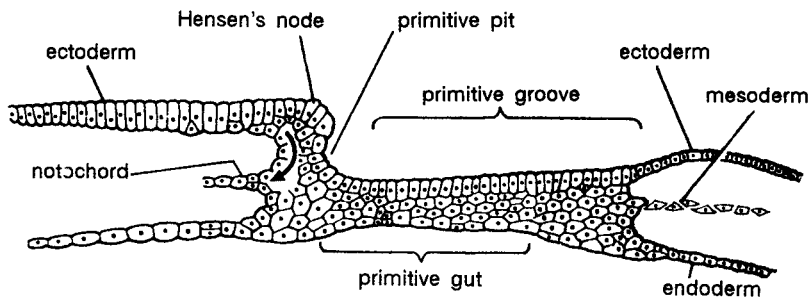

Fig. 12. Chick embryo : L.S. of 17 hours of incubation.

## 13. Chick Embryo : Whole Mount of 18 Hours of Incubation

### Comments :

- (1) After 18 hours of incubation the **notochord** has become markedly elongated, forming a prominent structure (Fig. 13).
- (2) **Notochord** extends towards cephalic region in the mid-line from Hensen's node.
- (3) 18 hours incubated embryo is spoken of as being in the **head process stage**.

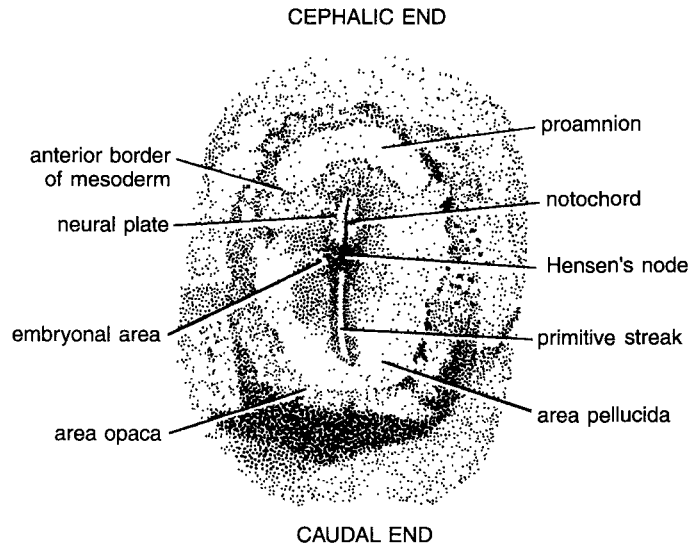

Fig. 13. Chick embryo : Whole mount. 18 hours of incubation.

- (4) At the tip of the notochord **neural plate** develops. Caudal and cephalic ends are seen.
- (5) In front of notochord and neural plate there is a space called as **pro-amnion**.
- (6) **Embryonic area**, anterior border of mesoderm **area pellucida** and **area opaca** become more prominent.
- (7) Primitive streak gradually decreases in size.

**Identification :** Since it has proamnion hence it is whole mount of **chick embryo after 18 hours of incubation.**

**14. Chick Embryo : L.S. of 18 Hours of Incubation**

**Comments :**

- (1) Incubated embryo shows advanced inner structure.
- (2) **Ectoderm** is shown by striated lines, the cells of **mesoderm** are represented by heavy angular dots and endoderm is represented by stippling backed by a single line.

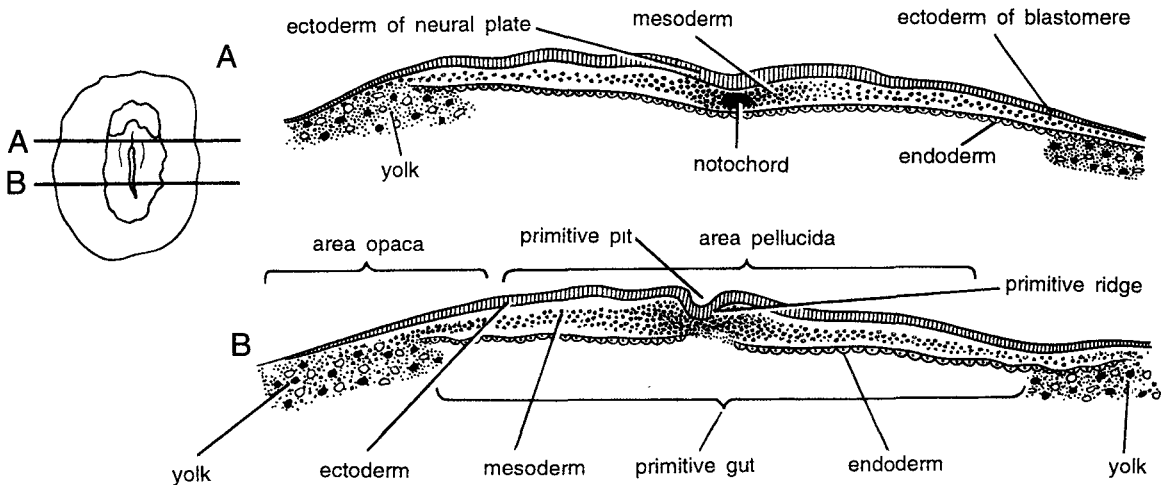

Fig. 14. Chick embryo : (A) and (B), L.S. of 18 hours of incubation.

- (3) Section A shows yolk, ectoderm of neural plate, notochord, mesoderm, ectoderm and endoderm of blastoderm. Section B shows yolk, endoderm, primitive pit, primitive ridge, mesoderm and primitive gut, area pellucida and area opaca.

**Identification :** Since the sections shows neural plate (A) and primitive pit (B) hence they are sections of chick embryo L.S. after 18 hours of incubation.

## 15. Chick Embryo : Whole Mount of 24 Hours of Incubation

### Comments :

- (1) At 24 hours of incubation the folding of the neural plate is much more clearly marked. In stained and transparent preparation of entire embryo neural folds appear as a pair of dark bands forming neural groove (Fig. 15).
- (2) Neural folds at cephalic end are more prominent than at caudal end.
- (3) Foregut is also established at this stage and the gut caudal to foregut called as midgut and the opening from midgut into foregut, namely anterior intestinal portal, also appears.
- (4) In the middle, four pairs of somites are seen. The Hensen's node is pushed caudally and primitive streak is further reduced.
- (5) Other structures seen are area opaca vitellina, ectoderm of head, area pellucida, mesoderm, blood island, area vasculosa, notochord, mesenchyme, proamnion, Hensen's node, sub-cephalic pocket and unsegmented mesoderm.

**Identification :** Since it has neural fold and above features hence it is whole mount of chick embryo of 24 hours of incubation.

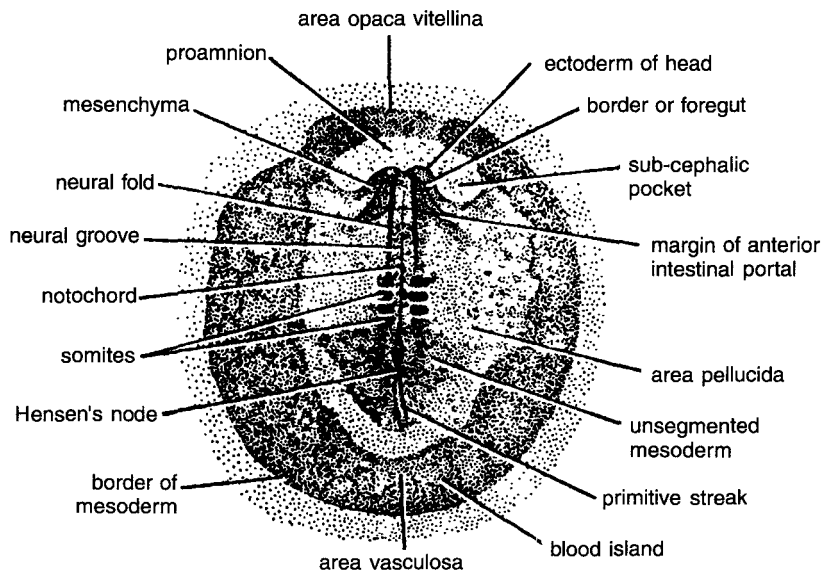

**Fig. 15.** Chick embryo : Whole mount. 24 hours of incubation.

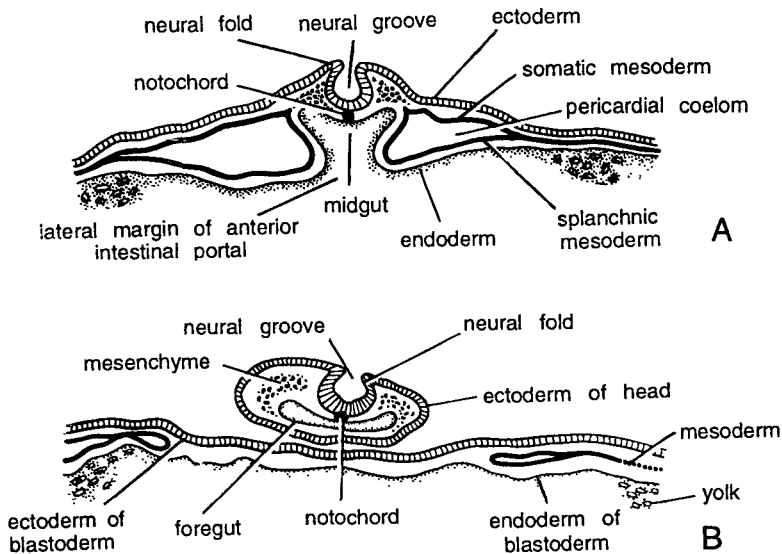

Fig. 16. Chick embryo : (A) and (B) T.S. 24 hours of incubation.

## 16. Chick Embryo : T.S. Passing Through 24 Hours of Incubation

### Comments :

#### [A] T.S. passing through head

- (1) T.S. passing through head region shows neural plate folded to form a complete neural tube.
- (2) Beneath neural fold is **notochord**.
- (3) Other structures seen in section are **mesenchyme**, **foregut**, **ectoderm of head**, **mesoderm** and **endoderm of blastoderm** and **ectoderm of blastoderm**.

#### [B] T.S. through mid-body

- (1) Shows formation of **somites** and changes in mesoderm.
- (2) **Mesoderm** is differentiated into dorsal mesoderm, intermediate mesoderm and lateral mesoderm.
- (3) Dorsal **mesoderm** forms somites, lateral mesoderm differentiates into **somatic** and **splanchnic** layers and **intermediate mesoderm** forms nephrotomic plate.
- (4) Other structures seen are **ectoderm**, **endoderm**, **lateral margin of anterior intestinal portal**, **midgut** and **pericardial coelom**.

**Identification :** Since sections (A) has neural groove, (B) has somatic and splanchnic mesoderms and above features hence they are transverse sections of **chick embryo after 24 hours of incubation**.

## 17. Chick Embryo : Whole Mount of 28 Hours of Incubation

### Comments :

- (1) Entire embryo of 28 **hours** of incubation shows marked advance in the development of cephalic region (Fig. 17).
- (2) **Neural folds** completely fuse forming **neural tube**, which becomes completely separated from superficial ectoderm.

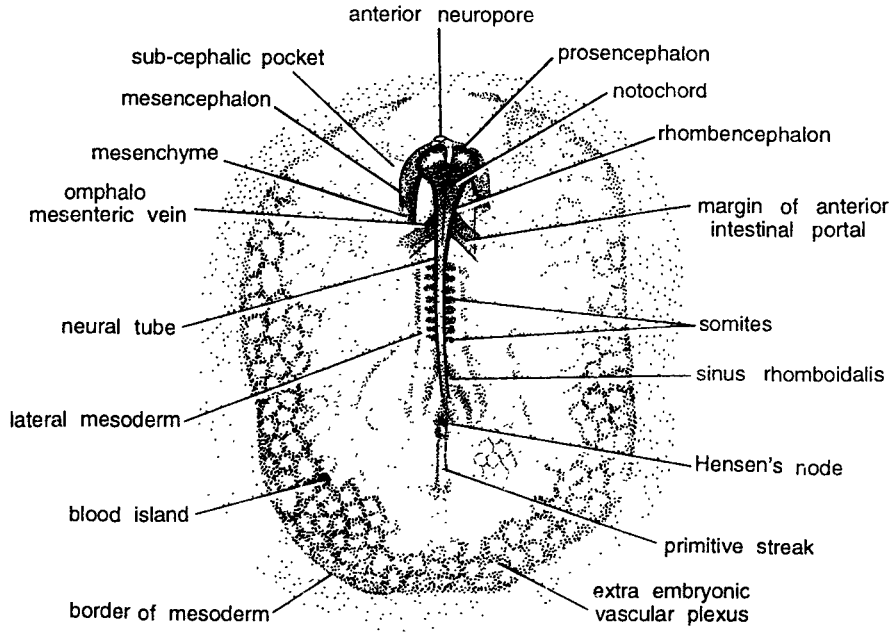

Fig. 17. Chick embryo : Whole mount. 28 hours of incubation.

- (3) **Head** projects free from blastoderm.
- (4) Three primary brain vesicles, namely **prosencephalon** (forebrain), **mesencephalon** (mid-brain) and **rhombencephalon** (hind brain) are differentiated.
- (5) Eight pairs of somites develop.
- (6) Anterior **neuropore** still remains open.
- (7) **Hensen's node** still pushed back and **primitive streak** becomes much smaller.
- (8) Other structures seen in section are anterior **intestinal portal**, **extra-embryonic vascular plexus**, **blood island**, **omphalomesenteric vein** and **sub-cephalic pocket**, **blood island**, **lateral mesoderm** **border of mesoderm** and **mesenchyme**.

**Identification :** Since the embryo shows divisions of brain cavities and above features, hence it is whole mount of **chick embryo of 28 hours of incubation**.

## 18. Chick Embryo : T.S. Passing Through 28 Hours of Incubation

### Comments :

- (1) T.S. through 28 hours of incubation shows formation of **heart** from mesoderm (Fig. 18).
- (2) **Epi-myocardium**, **endocardial primordium** and cardiac jelly are seen.
- (3) The section also shows closed **neural canal**, **notochord**, line of fusion of margins of anterior **intestinal portal**, **somatopleure**, **splanchnopleure**, **pericardial coelom**, **foregut**, **dorsal mesocardium** and ventral mesocardium are seen.

**Identification :** Since the section contains endocardial primordium and above structure hence it is T.S. of **chick embryo of 28 hours of incubation**.

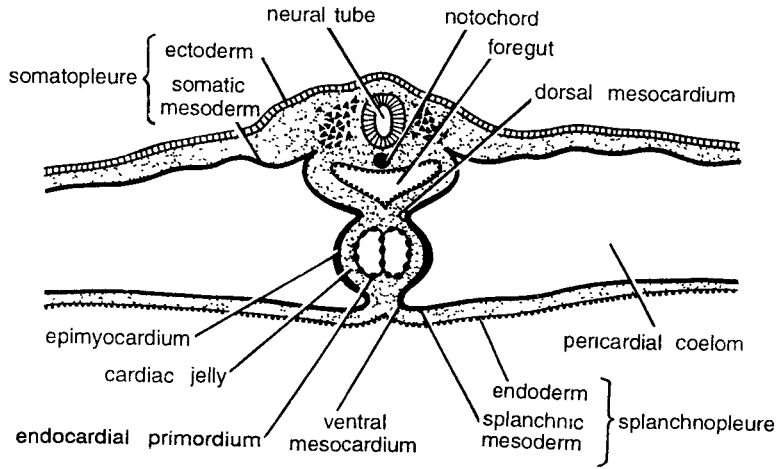

Fig. 18. Chick embryo : T.S. 28 hours of incubation.

## 19. Chick Embryo : Whole Mount of 33 Hours of Incubation

**Comments :**

- (1) Thirty-three hours incubated embryo shows some of the fundamental steps in the formation of **central nervous system** and **circulatory system**.

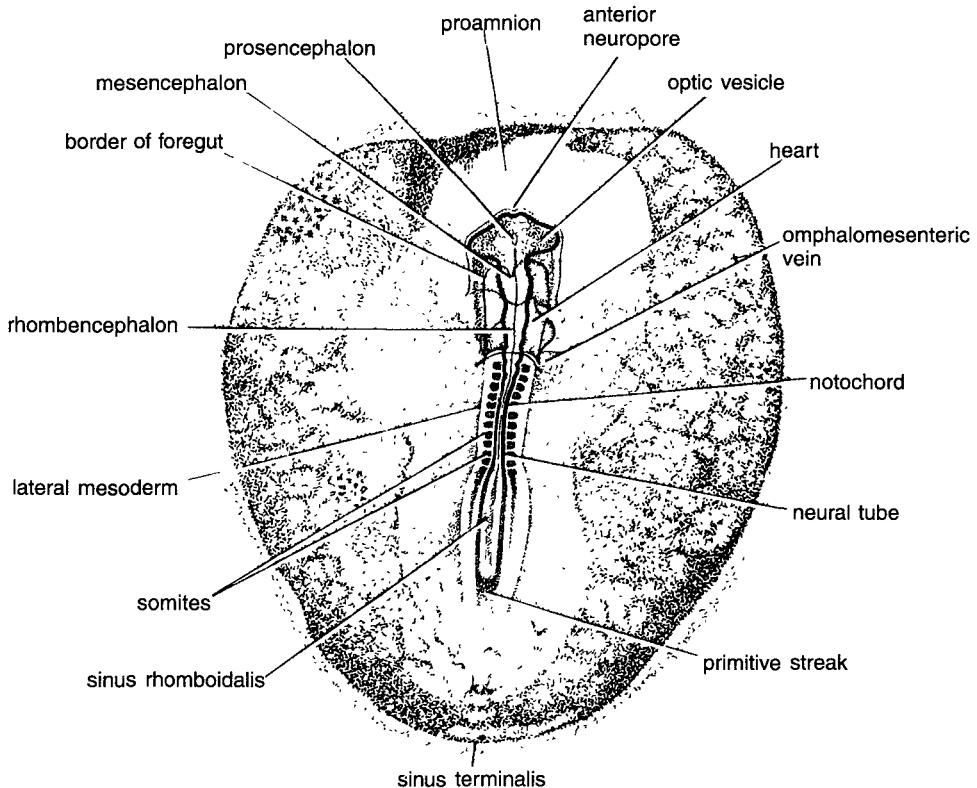

Fig. 19. Chick embryo : Whole mount. 33 hours of incubation.

- (2) Various **neuromeric** enlargements form brain regions.
- (3) Brain is differentiated into **prosencephalon** (fore brain), **mesencephalon** (mid brain) and **rhombencephalon** (hind brain).
- (4) Optic vesicles are established as paired lateral outgrowths of the prosencephalon.
- (5) **Infundibulum** is formed as a sort of depression in the floor of the prosencephalon.
- (6) **Twelve pairs of somites** are formed.
- (7) Mid-region of the **heart** is considerably dilated and bent to the right.
- (8) Anterior **omphalomesenteric** veins have developed. Border of foregut is formed.
- (9) **Primitive streak** becomes shorter because of the lengthening of the neural tube.
- (10) **Proaminon, neural tube, notochord, sinus rhomboidalis** and **sinus terminalis** are also present.

**Identification :** Since it has 12 pairs of somites and above feature hence it is whole mount of **chick embryo of 33 hours of incubation.**

## 20. Chick Embryo : T.S. Passing Through 33 Hours of Incubation

### Comments :

- (1) This section shows **ectoderm, prosocoel, opticoel, mesenchyme, somatic mesoderm, splanchnic mesoderm** and **endoderm** and **yolk** (Fig. 20).
- (2) It shows mid-structures namely, **mesocoel, anterior cardinal vein, dorsal aortic root, somatopleure, splanchnopleure, foregut, notochord** and ventral aortic root.

**Identification :** Since the section shows somatopleure, splanchnopleure and above features hence it is T.S. of **chick embryo passing through 33 hours of incubation.**

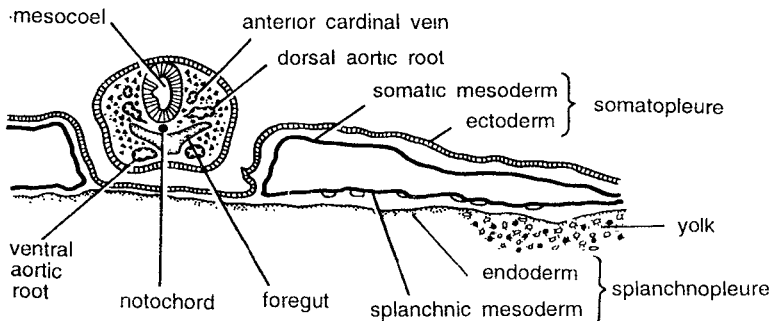

**Fig. 20.** Chick embryo : T.S. 33 hours of incubation.

## 21. Chick Embryo : Whole Mount of 43 Hours of Incubation

### Comments :

- (1) 43 hours incubated embryo shows **cranial flexure** and **torsion** (Fig. 21).
- (2) Cephalic region of embryo is **twisted** in such a way that left side comes to lie next to the yolk and right side away from yolk.
- (3) Brain is differentiated into **prosencephalon, mesencephalon, metencephalon** and **myelencephalon**.
- (4) **Heart** becomes 4 chambered. It is differentiated into **ventricular, arterial** and **sinus regions**. **Truncus arteriosus** also develops.
- (5) **Auditory pit** also makes its appearance.



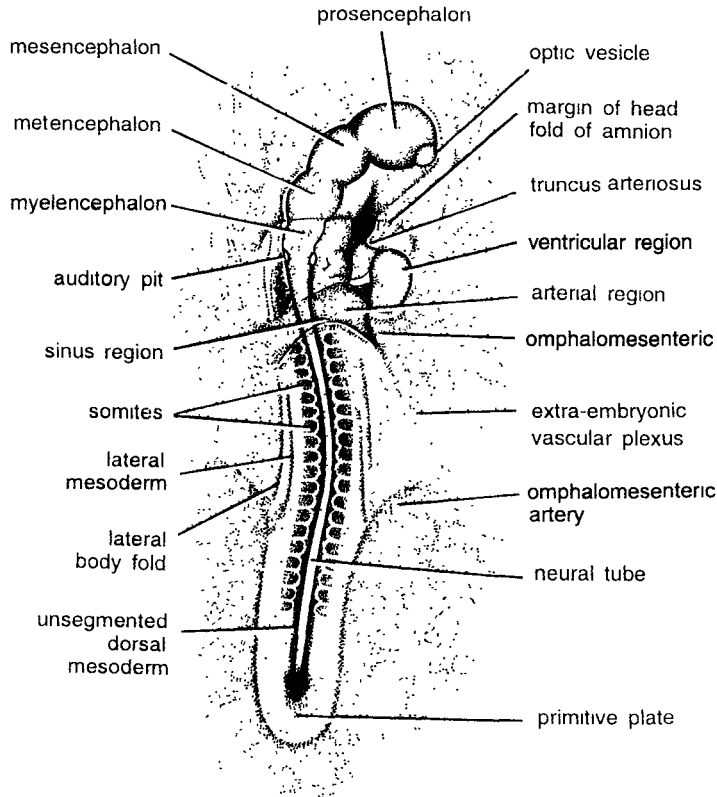

Fig. 21. Chick embryo : Whole mount. 43 hours of incubation.

- (6) Vitelline vessels communicate with **omphalomesenteric vein**. Omphalomesenteric arteries and extra-embryonic vascular plexus are well developed.
- (7) **Nineteen pairs of somites** are formed.
- (8) **Primitive streak** diminishes to a small primitive plate. Head fold margin develops.
- (9) **Neural plate** becomes well developed.
- (10) **Lateral mesoderm** insegmented mesoderm is seen. After 43 hours of incubation, the embryo develops rudiments of most of the organs.

**Identification :** Since it has 10 pairs of somites and above features, hence it is whole mount of **chick embryo of 43 hours of incubation**.

## 22. Chick Embryo : Whole Mount of 72 Hours of Incubation

### Comments :

- (1) After 72 hours of incubation, body is affected throughout by torsion and entire body is turn to 90°.
- (2) **Torsion** is complete, well posterior to the level of heart, but caudal portion of embryo is not turned on its side (Fig. 22).
- (3) Due to the **cranial** and **cervical** flexures, the long axis of the embryo shows nearly right angled bends in the mid brain and in the neck region.
- (4) **Mid-body** becomes concave.
- (5) **Visceral arches** develop.
- (6) **Mandibular arch** forms caudal boundary of oral depression and becomes more distinct.

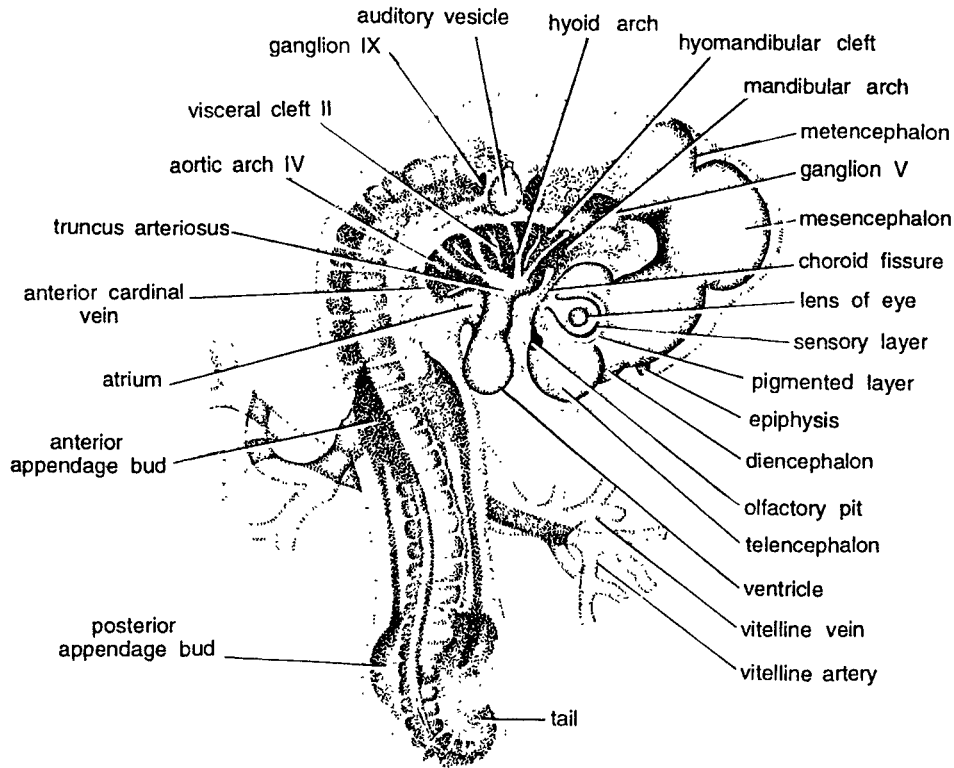

Fig. 22. Chick embryo : Whole mount. 72 hours of incubation.

- (7) **Nasal pits** appear as shallow depressions.
- (8) **Appendage rudiments** also make their appearance.
- (9) **Cephalization** is going on. Telencephalon also develops **anterior appendage bud** near mid body and posterior appendage near the tail.
- (10) In the **eye**, **lens**, **sensory** and **pigmented** layers are differentiated.
- (11) Number of somites increases to 36 pairs. Vitelline arteries and vitelline veins also make their appearance.

**Identification :** Since it contains 36 pairs of somites and above features, hence it is whole mount of **chick embryo of 72 hours of incubation.**

### CHICK EMBRYO : PRESERVED

Take one dozen fertilized eggs and incubate them in a incubator. Take out incubated eggs after 3, 6, 12, 18 and 21 days and preserved them in formaline. Study the developing embryos.

### 23. Chick Embryo : Three Days Old Formalin Preserved Whole Embryo from Ventral Side

**Comments :**

- (1) After 3 days to embryo after torsion becomes like telephone receiver. It bends at 90°.
- (2) Body divided into broad head and narrow tail (Fig. 23).

- (3) Three divisions of brain namely **prosencephalon**, **mesencephalon** and **metencephalon** are clearly seen.
- (4) Optic and auditory capsules have developed.
- (5) Sinus venosus has started developing.
- (6) Vitelline and allantoic vessels have started appearing. Right vitelline artery, posterior **vitelline artery**, **left vitelline artery** and **left vitelline vein** have appeared.

**Identification :** Since the embryo has shape of telephone receiver and above features, hence it is **chick embryo 3 days old**.

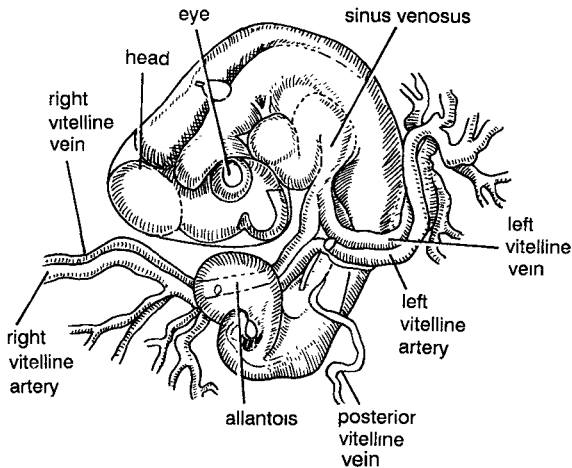

**Fig. 23.** Chick embryo : Formalin preserved 3 days old specimen.

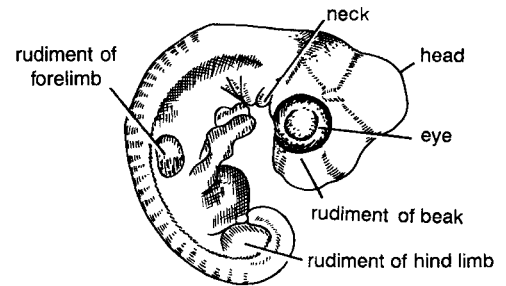

**Fig. 24.** Chick embryo : Formalin preserved 6 days old specimen.

## 24. Chick Embryo : 6 Days Old Formalin Preserved Whole Embryo from Dorsal Side

### Comments :

- (1) After 6 days embryo has considerably grown with **broad head** and narrow bluntly ending tail.
- (2) **Prosencephalon**, **mesencephalon** and **metencephalon** have distinctly developed.
- (3) Optic vesicle has developed more.
- (4) Rudiments of anterior and posterior limbs are seen.
- (5) Toes contain **claw**.
- (6) Near head beak is also appearing.

**Identification :** Since above specimen has beak rudiment and above features, hence it is **chick embryo 6 days old**.

## 25. Chick Embryo : 12 Days Old Formalin Preserved Whole Embryo from Dorsal Side

### Comments :

- (1) After 12 days chick embryo take the shape of a bird (Fig. 25).
- (2) Body is distinctly divided into **head**, **neck**, **trunk** and **tail**.
- (3) Head contains **eyes** with developing **eyelids**.
- (4) Upper and lower **beaks** develop.
- (5) Forelimbs **develop** into **wings**.

(6) Hind limbs develop clawed toes.

**Identification :** Since the embryo has beak and above feature hence it is **chick embryo 12 days old**.

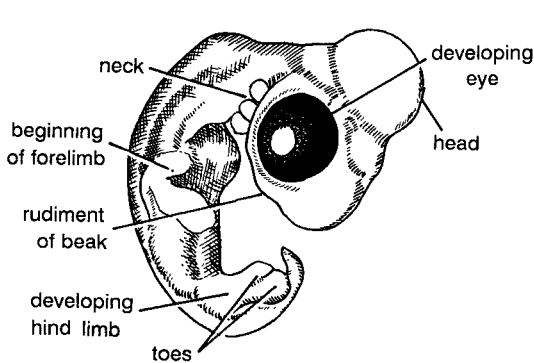

**Fig. 25.** Chick embryo : Formalin preserved 12 days old specimen from dorsal side.

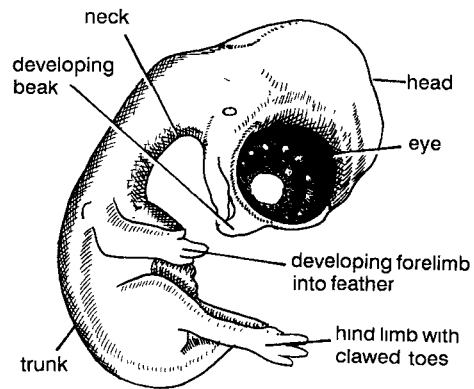

**Fig. 26.** Chick embryo : Formalin preserved 18 days old specimen from dorsolateral side.

## 26. Chick Embryo : 18 Days Old Formalin Preserved Whole Embryo from Dorsolateral Side

### Comments :

- (1) At this stage young chick considerably acquires features of adult bird (Fig. 26).
- (2) Body divided into **head, neck, trunk and tail**.
- (3) Eyes become well developed along with eyelids.
- (4) Pointed beak develops like pig.
- (5) Entire body is covered with down feathers called as plumes.
- (6) **Wings** develops. **Hind limb** develop **claw**.

**Identification :** Since the specimen contains down feathers and above features, hence it is **18 days old chick embryo**.

## 27. Chick Embryo : 21 Days Just Hatched Chick

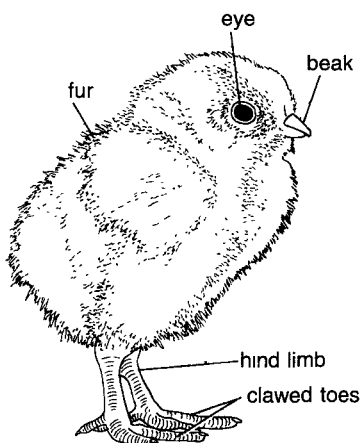

**Fig. 27.** Chick embryo : 21 days old just hatched chick.

### Comments :

- (1) After **21 days** chick comes out of the egg (Fig. 27).
- (2) Except beak and toes, entire body is covered with soft whitish **down feathers** which are called as plumes. **Plumes** are softer than silk and they do not contain **rachis**.
- (3) Plumes form **natal covering** over young chick.
- (4) Body is divided into **head, neck, trunk and tail**.
- (5) **Eyes and beak well developed**.
- (6) Rudiments of developing flying feathers distinct.

**Identification :** Since the chick contains over, feather all over body except beak and claws hence it is **just hatched chick**.

# Comparative Osteology = Study of Bones

# 10

Although the term **skeleton** denotes the bones inside the body for a layman, yet for students of science we refer the internal framework as **endoskeleton**, which is derived from mesoderm. The endoskeleton is an important system inside the body. On the basis of endoskeleton, two distinct divisions in the Fauna have been made—one **Chordata** and the other **Non-chordata**—with and without notochord respectively.

## Division of Endoskeleton

Broadly, the endoskeletal system is differentiated into two parts as follows :

### [I] Axial skeleton

It includes (1) **skull**, (2) **vertebral column**, (3) **ribs**, and (4) **sternum**.

### [II] Appendicular skeleton

Consisting of (1) **girdles** and (2) **limb bones**.

The variation in structure and disposition of skeleton in different classes of vertebrates is very wide. In case of fishes endoskeleton of *Scoliodon* has been described. Comparative osteology has been taken up in case of **Frog** (Amphibia), **Varanus**

(Reptilia), **Fowl** (Aves) and **Rabbit** (Mammalia). For convenience, the following arrangement has been followed :

- (1) **Skull** (dorsal, ventral and lateral views) and skull bones.
- (2) **Vertebral column**—different vertebrae.
- (3) **Girdles**—pectoral and pelvic.
- (4) **Limb bones** —Forelimb and hind limb.

## Osteological Terms

The following terms are frequently used in the study of osteology :

- (1) **Endoskeleton**. Internal framework of bones derived from mesoderm.
- (2) **Axial skeleton**. Endoskeleton found along the axis of the body.
- (3) **Appendicular skeleton**. Endoskeleton appended or added to axial skeleton and chiefly meant for **limbs** and **girdles**.
- (4) **Vertebral column**. The original notochord in all vertebrates is broken into different units, called *vertebrae*, which are segmentally arranged.
- (5) **Centrum, neural spine, neural arch and neural canal** are found in a vertebra.

- (6) **Pre-zygapophyses.** Articular processes by which vertebrae articulate with each other. Pre-zygapophyses are a pair of processes on the anterior face of vertebra.
- (7) **Post-zygapophyses.** A pair of processes present on the posterior face of vertebra.
- (8) **Transverse processes.** These are processes arising from the body of a vertebra or its neural arch. These are of the following types according to their mode of origin.
- (i) **Diapophyses.** Transverse processes arising from the base of neural arch.
  - (ii) **Parapophyses.** Transverse processes arising from the centrum.
  - (iii) **Basapophyses.** Transverse processes arising from ventro-lateral sides of centrum.
  - (iv) **Pleurapophyses.** Transverse processes arising from the middle of arch.
  - (v) **Hypapophyses.** Processes arising from the median ventral position of centrum.
  - (vi) **Metapophyses.** These are the two outgrowths arising just above pre-zygapophyses.
  - (vii) **Anapophyses.** Slender processes arising from just below the post-zygapophyses.
  - (viii) **Zygapophyses.** A pair of wedge-shaped processes present anteriorly on neural arch.
- (9) **Acetabulum.** A cup-shaped cavity in pelvic girdle.
- (10) **Acrocoracoid.** Found in birds, an additional process present dorsally on the coracoid.
- (11) **Acromian.** Found in mammals, a vertical process of scapular spine.
- (12) **Synovial cavity.** Cavity between two articulating bones or cartilages.
- (13) **Articular disc.** A pad of fibro-cartilage separating two articulating bones.
- (14) **Joints.** Gap between two articulating bones or cartilages.
- (15) **Immovable joints.** Joints between skull bones of fibrous nature.
- (16) **Movable joints.** Ball and socket joints.
- (17) **Condyle.** A ball-like swelling at the end of a bone for articulation.
- (18) **Deltoid ridge.** A triangular and flattened outgrowth near head of humerus for muscle attachment.
- (19) **Asterospondylous.** The calcified area, star-like in centra.
- (20) **Cyclospendylous.** The calcified area, centrally placed in centra.
- (21) **Tectospondylous.** The central calcified area alternates with fibrous material.
- (22) **Procoelous.** Centrum concave in front and convex behind.
- (23) **Opisthocelous.** Centrum convex in front and concave behind.
- (24) **Chondrocranium.** Comprises of cartilaginous cranium and cartilages of sense capsules.
- (25) **Splanchnocranium.** Series of cartilaginous arches supporting visceral clefts forming jaw skeleton.
- (26) **Dermocranium.** Dermal bones of skull.
- (27) **Amphistylic.** Double suspension. Upper jaw is directly attached to the otic region of cranium and the hyomandibular cartilage is movably attached to the otic region.
- (28) **Autodistylic.** It was found in extinct fishes in which upper jaw was attached to cranium by ligaments.
- (29) **Autostylic.** Upper jaw fused with cranium. It is of the following types :
- (i) **Holostylic.** Upper jaw fused with cranium and hyoid arch free from cranium, *e.g.*, Holocephali.
  - (ii) **Autostylic.** Lower jaw articulates with quadrate part of upper jaw. Hyoid arch and hyomandibular do not take part in suspensorium, *e.g.*, Lungfishes.
  - (iii) **Methystylic.** The symplectic bone derived from hyomandibular is attached to quadrate bone.
  - (iv) **Craniostylic.** Lower jaw directly articulates with a membrane bone, the squamosal of osteocranium. The quadrate forms incus and articular forms malleus of ear ossicles, *e.g.*, mammals.
- (30) **Hyostylic.** Upper jaw suspended by ligament to cranium and hyomandibular is movably articulated to otic region of cranium.

While comparing special features of skulls of **amphibians, reptiles, birds and mammals**, the skulls of amphibians and mammals are compared together, being **dicondylic**, while those of reptiles and birds are put together, being **monocondylic**.

## SCOLIODON : ENDOSKELETON (OSTEOLOGY)

The endoskeleton of dogfish is entirely cartilaginous. Axial skeleton consists of skull and vertebral column. Appendicular skeleton includes pectoral girdle, pelvic girdle and fin skeleton.

### 1. *Scoliodon* : Skull

**Skull.** Skull consists of : (A) Cranium and sense capsules, and (B) Visceral skeleton.

**Comments :**

#### [I] Cranium and sense capsules

Made up of a single piece of cartilage and divisible into 4 regions.

- (1) **Occipital region.** Posterior-most part having a median opening, the foramen magnum. Lateral sides contain occipital condyles and occipital crest in the middle.
- (2) **Auditory region.** Lies in front of occipital, in the form of two **auditory capsules** one on each side. Each capsule encloses internal ear. Protuberances for semicircular canals can be seen. This region dorsally contains openings for **endolymphatic duct** and **perilymphatic foramen**. Below **postorbital process**, **articular surface** for **hyomandibula** of hyoid arch is seen.

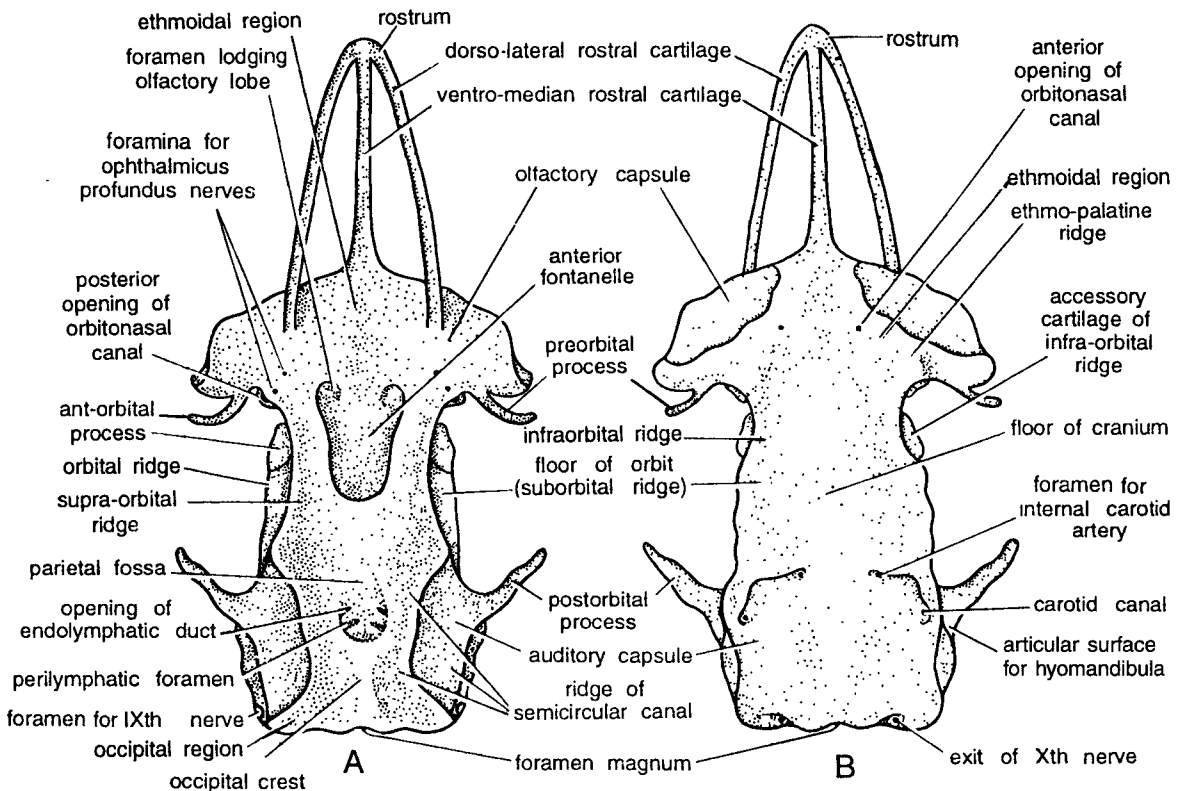

Fig. 1. *Scoliodon* : Skull A. Dorsal view, B. Ventral view.

- (3) **Orbital region.** Orbital region contains eye during life time. Each orbital region is made up dorsally by **supra-orbital** ridge, ventrally by **infra-orbital** ridge, anteriorly by **pre-orbital process** and posteriorly by post-orbital process. Number of foramina or nerves are found within orbit.
- (4) **Ethmoidal region.** It includes the anterior part of cranium, two nasal or **olfactory capsules** and **rostrum**. **Rostrum** is made by a **ventro-median rostral-cartilage** and two **dorsolateral rostral cartilages**.
- (5) Other structures seen in dorsal view are foramen lodging olfactory lobe, foramen for ophthalmicus profundus nerves, posterior opening of orbitonasal canal, anterior orbital process, parietal fossa, foramen for IXth nerve. Occipital crest, ridge of semicircular canal and anterior fontenelle.
- (6) Structures seen in ventral view are rostrum, anterior opening of orbitonasal canal ethmopalative ridge, accessory cartilage of infra-orbital ridge, floor of cranium, foramen for internal carotid artery, carotid canal, and exit of IXth nerve.

### [III] Visceral skeleton

It forms **jaws**, **skeleton of pharynx** and a series of **U-shaped visceral arches** around buccal cavity and pharynx. Important arches are :

- (1) **First or mandibular arch.** It is made up of two segments. Dorsal segment is called as palatopterygoquadrate forming upper jaw. Lower segment is called as Meckel's cartilage forming lower jaw.
- (2) **Second or hyoid arch.** It consists of basihyal, ceratohyal and hyomandibular. Jaws are suspended through hyomandibula and this is called as **hyostylic suspensorium**.
- (3) **Branchial arches.** Remaining 5 visceral arches are known as branchial arches. Each branchial arch consists of 4 rod-like pieces : dorsal pharyngobranchial, lateral epibranchial and ceratobranchial and ventral hypobranchial. Only epibranchials and ceratobranchials bear gill rays supporting gills.

## 2. *Scoliodon* : Vertebral Column

### Comments :

It consists of 130 vertebrae divided into **trunk** and **caudal regions**. Vertebrae are amphicoelous.

- (1) **Trunk vertebra.** It consists of neural spine, neural canal, neural arch, passage for notochord and transverse processes a ventral, thick, cylindrical centrum, transverse processes.
- (2) **Caudal vertebra.** It differs from trunk vertebra because its transverse processes meet and fuse to form below a haemal arch enclosing a haemal canal, spine. Upper section shows neural spine, neural canal, neural arch and uncalcified area in centrum.

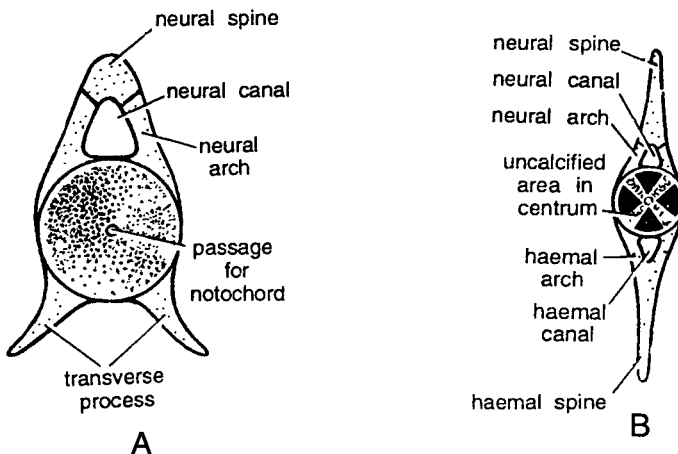

Fig. 2. *Scoliodon* : A. Complete trunk vertebra, B. Caudal vertebra in T.S.



### 3. *Scoliodon* : Pectoral Girdle and Fins

#### Comments :

- (1) **Pectoral girdle.** U-shaped structure made up of right and left halves united mid-ventrally. Each half is made up of **coracoid portion**, **scapular portion** and **suprascapular portion**. Pectoral girdle is embedded in lateral and ventral body wall posterior to gills in the region of heart. Pectoral girdles provide attachment to myotomes, pectoral fins and other muscles. Pectoral girdle also supports and protects heart.
- (2) **Pectoral fins.** A pectoral fin is made up of basal and radial cartilages. Basal cartilages are **propterygium**, **mesopterygium** and **metapterygium**. Proximally these cartilages articulate with scapular and coracoid portions of pectoral girdle. From basal cartilages extend numerous radial cartilages or somactidia, each made up of 2 or 3 segments.
- (3) Distal somactidia contain two sets of long numerous thread-like stiff and horny fin rays or **ceratotrichia** which support the peripheral membranous part of pectoral fin.
- (4) Coracoid portion contains foramina for **branchial artery and nerves**.

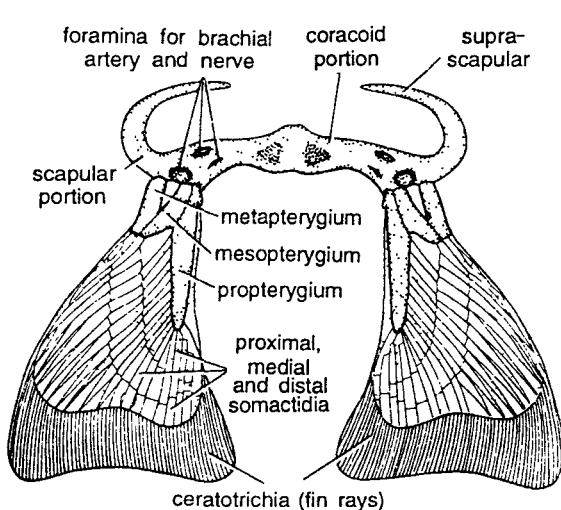

Fig. 3. *Scoliodon* : Pectoral girdle and fins.

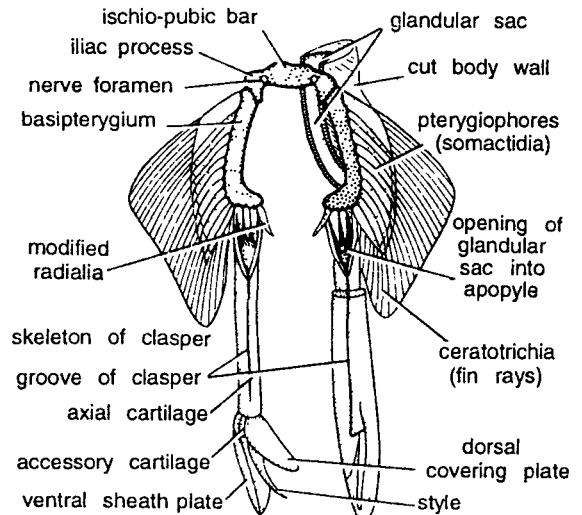

Fig. 4. Pelvic girdle and fins.

### 4. *Scoliodon* : Pelvic Girdle and Fins

#### Comments :

- (1) **Pelvic girdle.** Made up of a simple flattened and transverse cartilaginous rod called **ischio-pubic bar**, having a small blunt iliac process on either side projecting above the acetabular facet for articulation of the basal cartilage of pelvic fin.
- (2) **Pelvic fins.** Skeleton of a pelvic fin has a single large and curved basal cartilage called as **basipterygium**. From basipterygium 15 or more slender radials or **somactidia** are given. Associated with pelvic girdle in male dog-fish are claspers. Each clasper contains **accessory piece**, **dorsal covering plate**, **ventral sheath plate** and **style**.
- (3) **Median fins.** Skeleton similar to paired fins.

Other structures seen are modified radials, skeleton of clasper, groove of claspers, axial cartilage ceratotrichia cut body wall glandular sac nerve foramin and opening of glandular sac into apophyle.

## SKULL BONES

### 1. Skull of Frog

- (1) **Dorsal view.** Various structures seen are septo-maxillary, external nares, vomer maxilla, orbital fossa, pterygoid, quadratojugal, quadrate cartilage, exoccipital, occipital condyle, foramen magnum, auditory capsule, fenestra ovalis, prootic, squamosal, fronto-parietal, diamond-shaped area sphenethmoid, nasal, cartilaginous nasal or olfactory chamber and premaxilli.
- (2) **Ventral view.** Various structures seen are premaxilla, cartilaginous nasal capsule, vomer, sphenethmoid, fronto parietal, parasphenoid, squamosal, columella, quadratojugal, auditory capsule, fenestra ovalis, occipital condyle, foramen for IX and X nerves, exoccipital quadrate cartilage, prootic, pterygoid, foramen for V and VII nerves, foramen for VI nerve, foramen for II nerve, orbital fossa, maxilla, palatine, foramen for V nerve and internal nares.

### 2. Skull of Rabbit

- (1) **Dorsal view.** Skull bones seen in dorsal view are anterior nares, pre-maxilla, nasal, maxilla, frontal, jugal, parietal, squamosal, tympanic bulla, interparietal, supraoccipital, external auditory meatus, zygomatic process of squamosal, supra-orbital process of frontal, zygomatic arch, zygomatic process of maxilla, maxillary process of frontal, nasal or frontal process of premaxilla and I incisor tooth.
- (2) **Ventral view.** Skull bones seen in ventral view are incisor tooth, palatine process of pre-maxilla, anterior palatine foramen, palatine process of maxilla, premolar teeth, zygomatic process of frontal, zygomatic process of squamosal, eustachian canal, external auditory meatus, para-occipital process of exoccipital, supraoccipital, foramen magnum periotic, occipital condyle, exoccipital, mastoid process, tympanic bulla, basioccipital, alisphenoid, basisphenoid, pterygoid, pituitary foramen, presphenoid, palatine, vomer, maxilla, pre-maxilla, nasal and II incisor tooth.
- (3) **Lateral view.** Skull bones seen in lateral view consists of premaxilla, I-incisor, II-incisor, zygomatic process of maxilla, premolars, molars, jugal, palatine, pterygoid, basisphenoid, basioccipital, tympanic bulla, paraoccipital process of exoccipital, occipital condyle, stylomastoid foramen for facial nerve, external auditory meatus, periotic, supraoccipital, interparietal, post tympanic process of squamosal, squamosal, zygomatic process of squamosal, parietal, alisphenoid, sphenoid fissure, supraoccipital process of frontal, frontal, optic foramen, orbitosphenoid, lacrymal, maxillary process of frontal, nasal or frontal process of premaxilla.

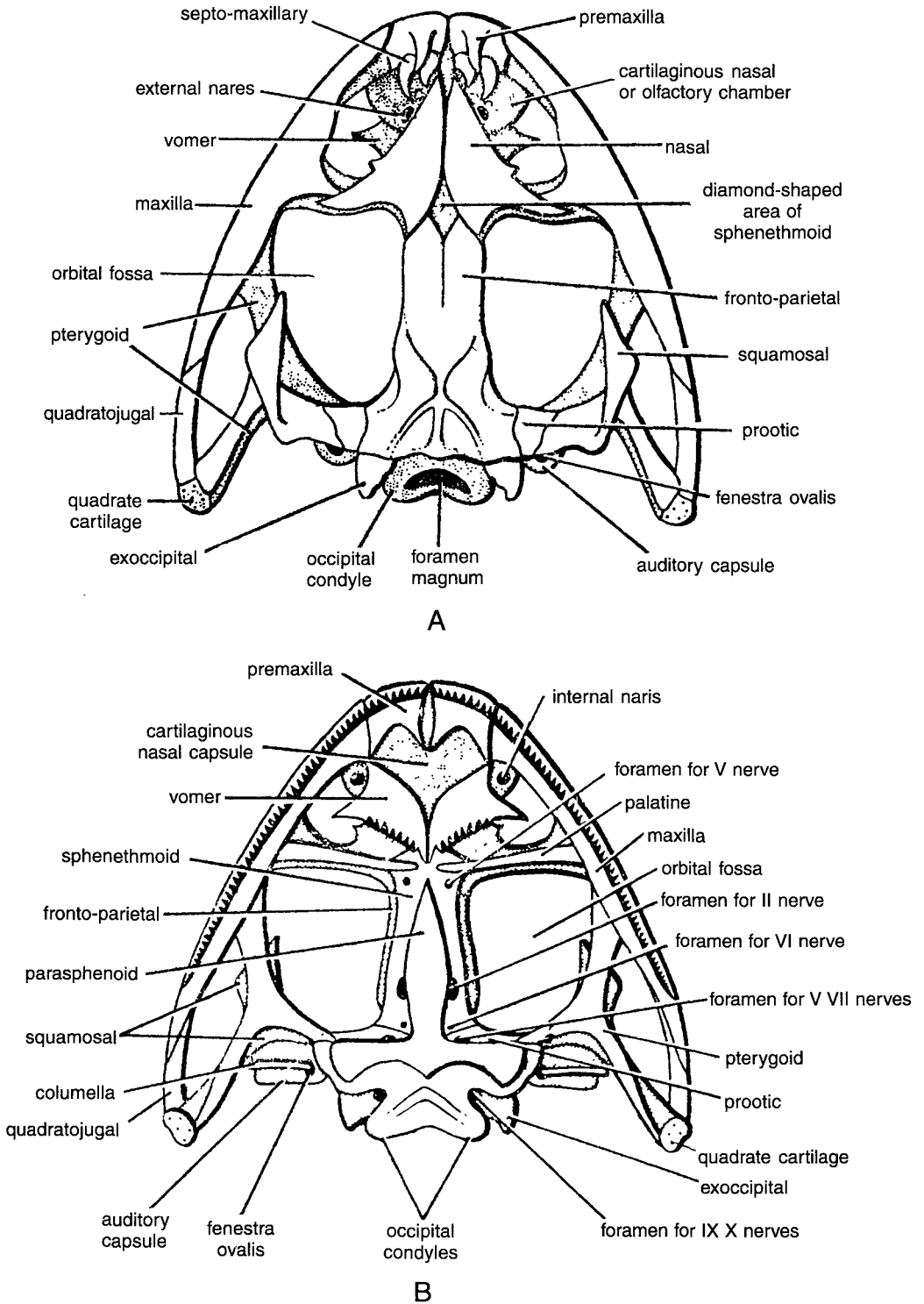

Fig. 5. Skull of Frog : A. Dorsal view, B. Ventral view.

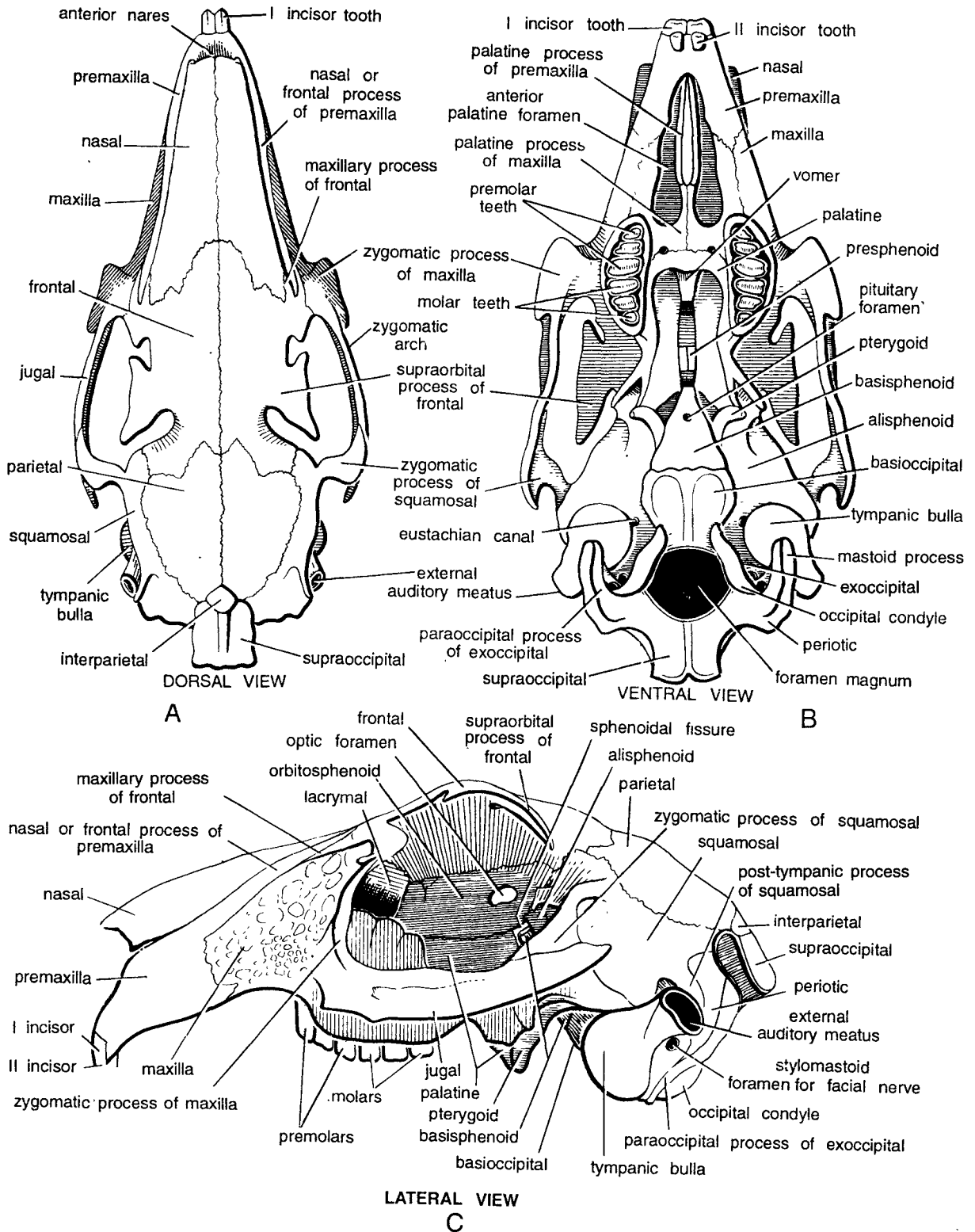

Fig. 6. Skull of Rabbit.

### 3. Skull of *Varanus*

- (1) **Dorsal view.** Various skull bones seen are as follows— Dorsal premaxillary foramen, septomaxillary nasal, prefrontal, lacrymal, supraorbital fossa, frontal parietal foramen, parietal, epipterygoid, prootic, supratemporal arch, supratemporal, prootic, supraoccipital, foramen magnum, columella, squamosal, quadrate, supratemporal fossa, postorbital, pterygoid jugal, transverse, palatine, ventral bogeler of inter orbital septum, vomer, maxilla, nasal process of premaxilla, premaxilla and paraoccipital process of exoccipital.
- (2) **Ventral view.** Various skull bones in ventral view consists of premaxilla, maxilla, vomer, ventral bogeler of inter orbital septum, palatine, transverse, jugal, sub-orbital fossa, pterygoid, postorbital, quadrate, squamosal, columella, basioccipital, paraoccipital process of exoccipital, occipital condyle, exoccipital, basisphenoid, parasphenoid, orbitosphenoid, ventrolateral process of frontal, position of posterior nare, vomer, vomerine aperture, apparatus for Jacobson's organ and vomeromaxillary process of premaxilla.
- (3) **Lateral view.** Various skull bones seen in lateral view consists of premaxilla, nasal process of premaxilla, nasal, prefrontal, interorbital septum, frontal, supraorbital, parietal, postorbital, supratemporal fossa, supratemporal arch, squamosal, supratemporal, prootic, epipterygoid, quadrate, occipital condyle, exoccipital, basisphenoid, pterygoid, orbitosphenoid, parasphenoid, transverse, palatine, jugal, lacrymal, maxilla, septomaxillary, dorsal premaxillary foramen, premaxilla.

### 4. Skull of Fowl

- (1) **Dorsal view.** Various skull bones seen are as under-premaxilla, external nares, nasal, maxilla lacrymal, jugal, orbit, quadratojugal, quadrate, parietal, supraoccipital, zygomatic process of frontal, frontal, maxillary process of premaxilla, palatine process of premaxilla and nasal process of premaxilla.
- (2) **Ventral view.** Various skull bones seen are nasal process of premaxilla, palatine process of premaxilla, maxillary process of premaxilla, frontal zygomatic process of frontal, zygomatic process of temporal basitemporal, basioccipital, occipital condyle, exoccipital, paramastoid process, tympanic cavities, pterygoid, common eustachian opening, parasphenoid rostrum, palatine vomer and internal naris.
- (3) **Lateral view.** Various skull bones seen in lateral view consists of maxillopalatine process of maxilla, nasal chamber nasal lacrymal, inter-orbital septum, frontal, olfactory frontal, optic foramen, zygomatic process of frontal parietal lamboidal crest, supraoccipital foramen of V nerve, occipital condyle, fenestra ovalis, tympanic cavity, fenestra rotundum, paramastoid process, eustachian opening, quadratojugal, quadrate, zygomatic process of temporal, pterygoid, jugal, palatine, maxilla, vomer and premaxilla.

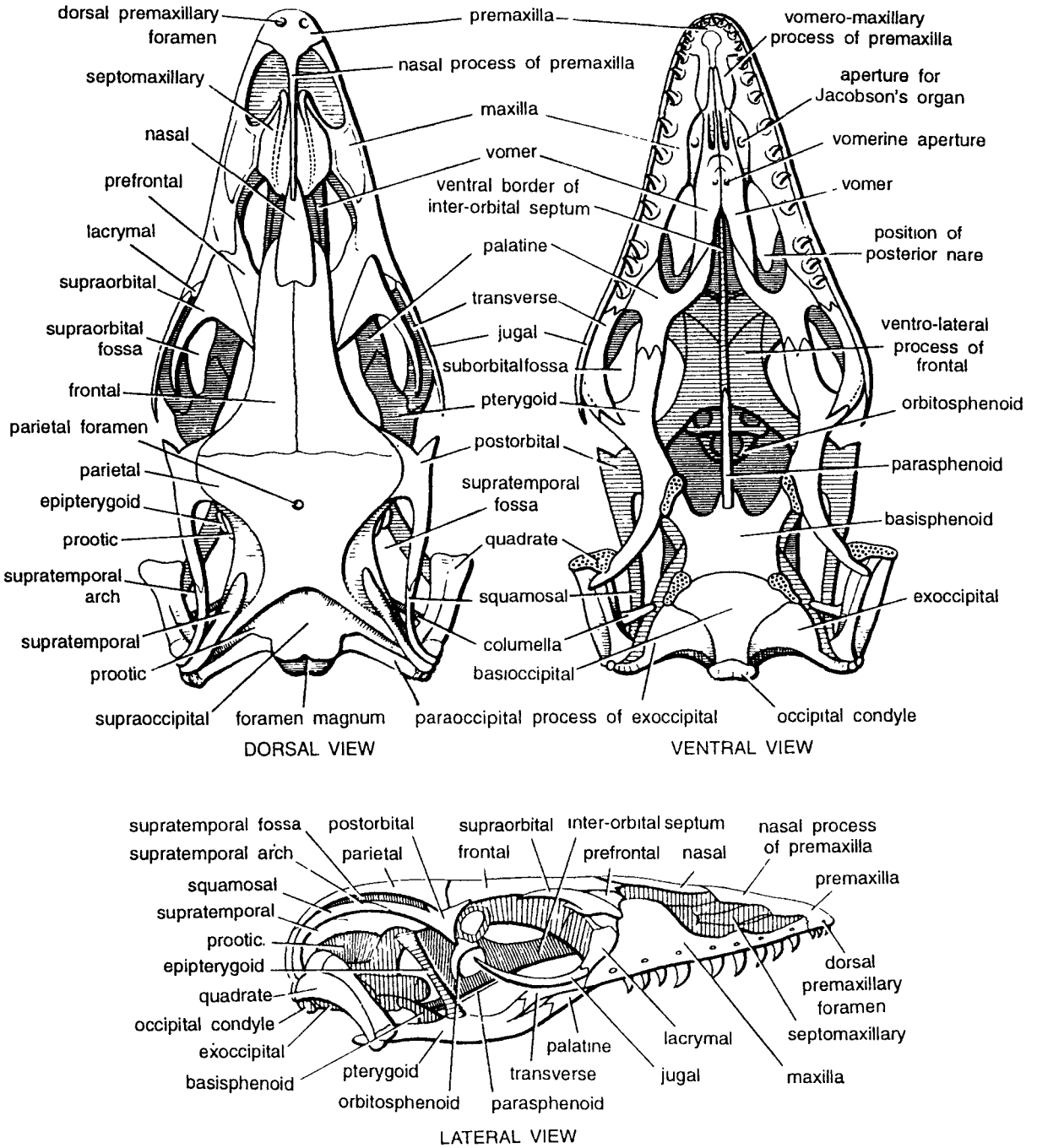
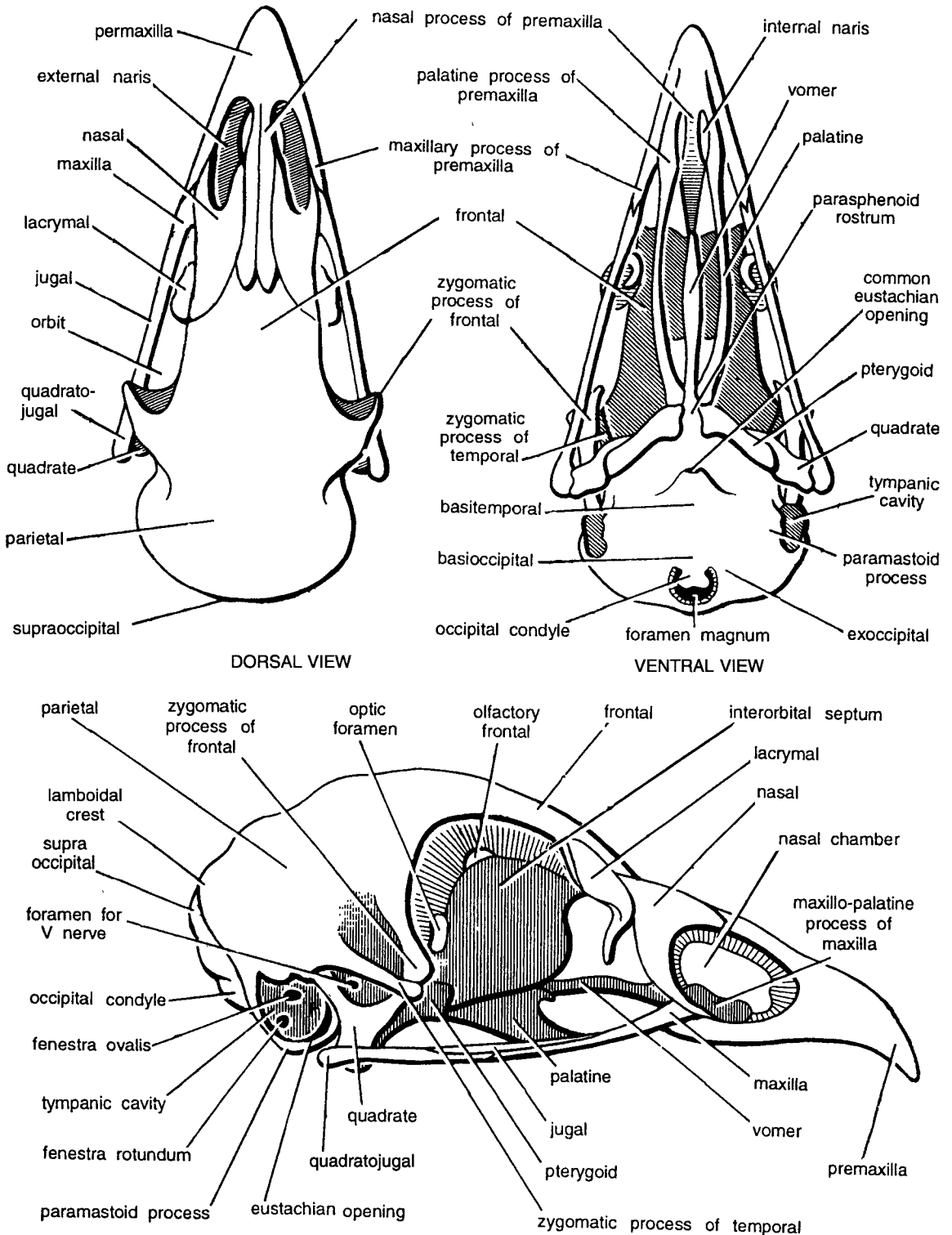

Fig. 7. Skull of *Varanus*.



LATERAL VIEW

Fig. 8. Skull of Fowl.

Table 1. Comparison of Skulls of Frog and Rabbit.

Skull of Frog	Skull of Rabbit
1. Skull is triangular in shape, broad and dorso-ventrally flattened.	1. Skull has narrow anterior and broad posterior end. No dorso-ventral flattening.
2. Tadpole <b>chondrocranium</b> persists in adult to a greater extent. Sense capsules and cranium largely made up of cartilage.	2. Original <b>chondrocranium</b> completely replaced by ossified bones in adult. Cranium and sense capsules made up of bones.
3. <b>Cranium</b> is smaller due to small size of brain and dorsally-placed orbits.	3. <b>Cranial</b> part is smaller but facial part is elongated. The orbits are laterally placed.
4. <b>Dicondylic</b> . Two occipital condyles.	4. <b>Dicondylic</b> . Two occipital condyles.
5. <b>Platybasic skull</b> . The inter-orbital septum is absent and so the cranium extends beyond orbits.	5. <b>Tropibasic skull</b> . The inter-orbital septum is present and so the brain box does not extend into orbits.
6. Sphenoid constitutes posterior wall of olfactory chambers. Basi, ali, orbito and pre-sphenoids, and supra and basioccipitals are absent.	6. Prefrontal, postfrontal, parasphenoid, quadratojugal absent, while pterygoids are much reduced.
7. Floor of brain box is formed by parasphenoid and roof by frontoparietals.	7. Floor of brain box formed by basisphenoid and presphenoid while roof by parietals and frontals.
8. Vomers and vomerine teeth present. Premaxillae and maxillae bear thecodont, polyphyodont and homodont teeth.	8. Vomers present, vomerine teeth absent. Premaxillae, maxillae and dentaries bear thecodont, diphyodont and heterodont teeth.
9. Occipital region made of exoccipitals.	9. Occipital region made of two exoccipitals, one basioccipital and one supraoccipital.
10. <b>Tympanic bulla</b> absent. Tympanic is ring-like.	10. <b>Tympanic</b> bone forms a flask-shaped tympanic bulla.
11. <b>Jaw suspensorium</b> is autostylic, in which lower jaw is attached to skull through a rod-like cartilaginous quadrate.	11. <b>Jaw suspensorium</b> is craniostylic in which the mandible articulates with squamosal of cranium.

Table 2. Comparison of Skulls of Varanus and Fowl.

Skull of Varanus	Skull of Fowl
1. <b>Chondrocranium</b> is well ossified. Skull is complicated and possesses several <b>replacing</b> and <b>investing bones</b> . It has considerable weight.	1. Skull compact, devoid of teeth and very light due to spongy bones and presence of air cavities. Lightness is in accordance with flying habit.
2. Beak absent. <b>Jaw bones possess teeth</b> .	2. <b>Distinct</b> feature of skull is the presence of a long pointed <b>beak without teeth</b> .
3. Skull bones are several, unpolished and with <b>distinct sutures</b> .	3. Skull bones very compact, closely fused, polished and with <b>obliterated sutures</b> .
4. <b>Cranium</b> is small.	4. <b>Cranium</b> greatly enlarged to accommodate the large brain.
5. <b>Monocondylic</b> skull. Single occipital condyle on the basioccipital, which articulates with atlas vertebra.	5. <b>Monocondylic</b> . Single occipital condyle articulates with atlas in such a way that skull can move freely sidewise.
6. Skull <b>tropibasic</b> . Vertical interorbital septum separates comparatively smaller orbits.	6. Skull <b>tropibasic</b> . The definite interorbital septum separates large-sized orbits.
7. Pre-frontal, supra-orbital, post-orbital and transverse bones present.	7. These bones absent.
8. Parietals fuse together forming a single bone and perforated by a parietal foramen. No occipital ridge.	8. Supra-occipital joins with parietals forming a large prominent ridge known as occipital or lamboidal ridge.
9. <b>Tympanic cavity</b> is small containing a single ear ossicle, the columella.	9. <b>Tympanic cavity</b> is large, hemispherical and having a single columella.
10. Teeth are polyphyodont, homodont, pleurodont and found on pre-maxillae, maxillae and dentaries.	10. Teeth absent. Palate <b>schizognathous</b> formed by vomers, palatines, pterygoids and palatal prolongations of maxillae.
11. <b>Suspensorium autostylic</b> .	11. <b>Suspensorium autostylic</b> .



## DISARTICULATED SKULL BONES

### 1. Disarticulated Skull Bones of Frog

The disarticulated skull bones comprise of occipital region, fronto-parietals, sphenethmoid, parasphenoid, columella, nasals, septo-maxillaries, vomers, premaxillae, maxillae, quadratojugals, quadrates, palatines, squamosals and pterygoids.

#### Comments :

- (1) **Occipital region.** (i) It is the posteriormost part of skull. It is formed by frontoparietals on dorsal side, parasphenoid on ventral side and a pair of bony exoccipitals on lateral sides, which enclose a large opening called **foramen magnum**. (ii) The spinal cord passes through the foramen magnum. (iii) Each exoccipital contains a condyle which articulates with a facet on atlas vertebra. (iv) Supraoccipital and basioccipital absent. (v) Externally each exoccipital is fused with cartilaginous auditory capsule, which is perforated by a minute opening, called **fenestra ovalis**. (vi) Anteriorly each auditory capsule is formed by a cartilaginous bone, called **prootic**.
- (2) **Frontoparietals.** (i) These form a pair of long and broad membranous bones, which are united in mid-dorsal line and cover entire brain box. (ii) In embryonic condition, frontals and parietals are separate; in adult they are completely fused. (iii) They extend up to sphenethmoid anteriorly and up to exoccipitals posteriorly.
- (3) **Sphenethmoid.** (i) It is a hollow tubular bone surrounding anterior end of the cranial cavity and can be seen only on sides. (ii) It is demarcated into anterior **ethmoidal portion** and posterior **sphenoidal portion** by a transverse partition. Ethmoidal region is further divided into right and left parts by a longitudinal division and each part encloses an olfactory sac. Sphenoidal region contains the forebrain. (iii) Major part of the bone is covered dorsally by 2 nasals and fronto-parietals and ventrally by parasphenoid.
- (4) **Parasphenoid.** (i) Parasphenoid is like a dagger, in the form of an inverted 'T' covering entire floor of cranium. (ii) The upper blade-like part extends up to the sphenethmoid, while side portion or handle extends up to auditory capsules.
- (5) **Columella.** (i) **Tympanic** cavity has a rod-like bone, the **columella auris**. Its outer end is attached to the tympanic membrane and inner end is attached to **fenestra ovalis**. (ii) Columella conducts sound vibrations up to the inner ear located inside the auditory capsule. Other structures seen are mediostapedal, extra-stapedal and supra-stapedal.
- (6) **Nasals.** (i) These form a pair of large triangular, flattened and membranous bones, which serve as roof of olfactory capsules. (ii) Nasals are united in median line. (iii) Anteriorly, they extend up to premaxillae and posteriorly they meet with frontoparietals and leave a diamond-shaped area before meeting.
- (7) **Septo-maxillary.** It is an irregularly-shaped small bone, associated anteriorly with nasal. It is composed of a basal plate and two unequal processes.
- (8) **Vomers.** (i) They are membranous bones covering the floor of the olfactory capsules. (ii) Each vomer is triangular in shape, lining the posterior nostril and containing 6 to 7 minute **vomerine teeth** along its postero-lateral margin. It has dorsal process and outer notches.
- (9) **Premaxilla.** (i) It is found in upper jaw at the tip of snout. (ii) It articulates with maxilla on each side. (iii) It is a small irregular bone, having a few conical **premaxillary teeth** along anterior lower margin. (iv) Dorsally a backwardly directed process partly forms inner boundary of external nostril.

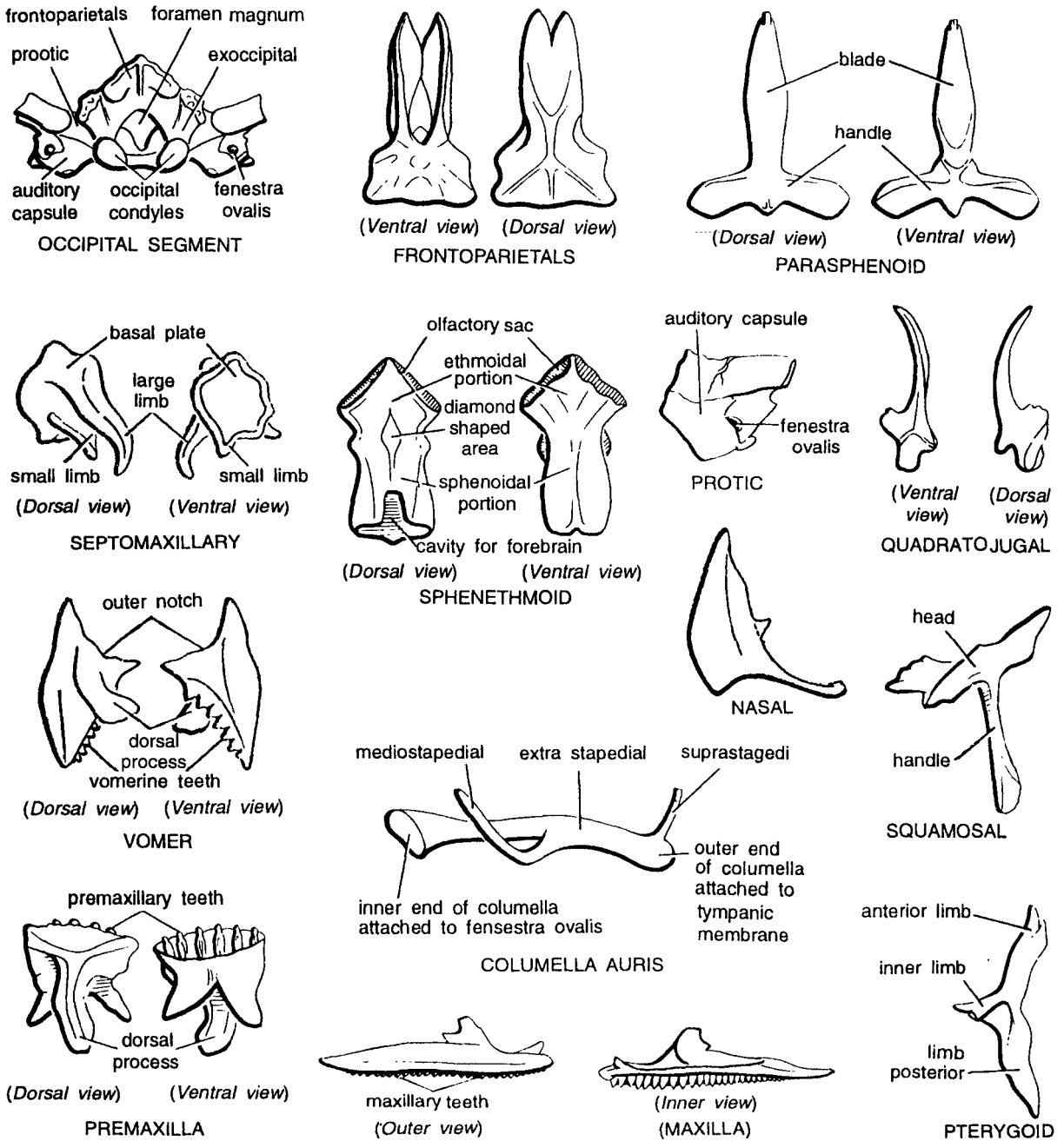

Fig. 9. Disarticulated skull bones of Frog.

- (10) **Maxilla.** (i) It constitutes major part of upper jaw. (ii) It is a thin, elongated, slightly curved bone joined behind by quadratojugal. (iii) It articulates partly with palatine and pterygoid. (iv) Maxilla is provided with several backwardly-directed conical and pointed maxillary teeth.
- (11) **Quadratojugal.** (i) It is easily recognized by being comma-shaped. (ii) It is found behind maxilla, forming posterior outer region of upper jaw. (iii) Its posterior region is broadened and articulates with quadrate cartilage.

- (12) **Quadrate.** (i) It is a rod-shaped suspension cartilage, which connects mandible with skull. (ii) Internally it is fused with auditory capsule and posteriorly attached to hind end of quadratojugal. (iii) It is completely concealed under pterygoid and squamosal.
- (13) **Palatine.** (i) It lines the antero-ventral side of each orbit. (ii) It is a long, delicate, transverse and rod-shaped bone, connecting anterior cranium with middle maxillae.
- (14) **Squamosal.** (i) It attaches with the posterior end of cranium on dorso-lateral side above pterygoid and it also forms postero-dorsal margin of the orbit, (ii) It is a hammer-shaped bone, having a free anterior limb, a short inner limb attached to auditory capsule and prootic and a larger outer limb attached to the quadratojugal.
- (15) **Pterygoid.** (i) It is a Y-shaped or three-rayed bone attached laterally to the posterior end of cranium. (ii) It also forms postero-ventral margin of orbit. (iii) The anterior ray joins with outer end of palatine and maxilla, the posterior ray joins with quadratojugal and quadrate and the inner ray articulates with parasphenoid and auditory capsule.

## 2. Disarticulated Skull Bones of Rabbit

The disarticulated skull bones of Rabbit include occipital region, squamosal, parietal, interparietal, basisphenoid and alisphenoids, presphenoid and orbitosphenoids, frontal, nasal, vomer, turbinals, periotic and tympanic bulla.

### Comments :

- (1) **Occipital segment.** (i) It encloses a large **foramen magnum** and is made up of **supraoccipital**, **exoccipitals** and **basioccipital** cartilaginous bones. (ii) Supraoccipital forms a squarish bulging and gives a pair of processes for muscle attachment and articulates with interparietals, squamosal and periotics. (iii) **Exoccipitals** bear **occipital condyles** and also give downwardly-directed paraoccipital processes. (iv) **Basioccipital** forms the floor and it articulates with basisphenoid in front and with prootic laterally.
- (2) **Squamosal.** (i) It is a more or less rectangular membrane bone found ventral to parietal. (ii) It gives a backward process, called **post-tympanic process**, over periotic and external auditory meatus. (iii) The outer surface contains a **zygomatic process** and undersurface contains a mandibular facet for articulation with condyle of lower jaw.
- (3) **Parietal.** (i) It forms major part of posterior cranial roof. (ii) Parietals are demarcated from alisphenoids by squamosals and they remain united mid-dorsally by a distinct suture. (iii) Posteriorly each parietal gives a **ventral process**.
- (4) **Interparietal.** It is a triangular membrane bone between parietals and supraoccipital.
- (5) **Basisphenoid and alisphenoids.** (i) Both constitute a compound bone. (ii) Basisphenoid is a flattened, triangular and median cartilaginous bone articulating with basioccipital. It also contains a depression meant for pituitary gland and is perforated by a minute **pituitary foramen**. (iii) Basisphenoid articulates with presphenoid in front and laterally with alisphenoid. (iv) The alisphenoids are closely and obliquely applied on either side of basisphenoid. They are wing-shaped and contain free parts. Alisphenoid contains external pterygoid process. On the side of pituitary foramen in sphenoidal fissure.
- (6) **Presphenoid and orbitosphenoids.** (i) They form a compound bone. (ii) Presphenoid is small laterally compressed median cartilaginous bone, forming floor of the frontal region of skull and anterior to basisphenoid. (iii) **Orbitosphenoids** are found on the sides of the presphenoid. They are partially fused and leave a central area, called **optic foramen**, intervened by interorbital foramen. They articulate with palatines anteriorly, with frontals dorsally, and with squamosals and alisphenoids posteriorly. They also form lateral walls of orbits and cranium.

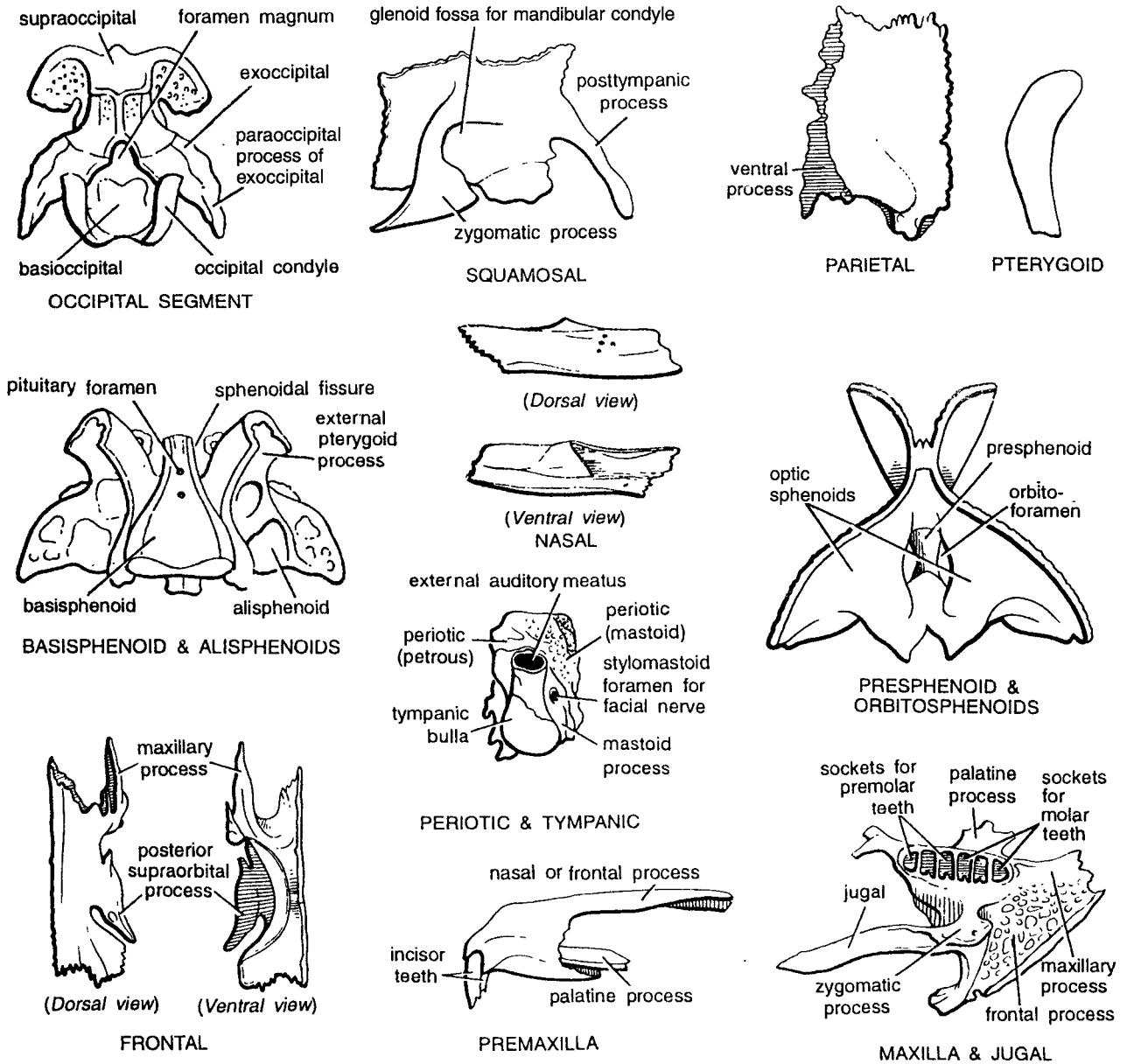

Fig. 10. Disarticulated skull bones of Rabbit.

- (7) **Frontals.** (i) They are two in number forming the roof and sides of frontal cranium. They unite together in mid-dorsal axis and with parietals posteriorly. (ii) Externally each frontal contains posters **supraorbital process** and ventrally articulated with orbitosphenoid.
- (8) **Nasals.** (i) They are narrow membrane bones forming roof of the olfactory chambers. (ii) The anterior ends form upper boundaries of external nostrils. (iii) Externally each nasal articulates with premaxilla.
- (9) **Turbinals.** **Olfactory** chambers contain irregularly-shaped compound bones consisting of ethmo-turbinal, maxillo-turbinal and naso-turbinal, which increase sensory area.

- (10) **Vomers.** (i) They are blade-like and slender bones, situated ventrally to olfactory capsules. (ii) They are fused and attached to nasal septum.
- (11) **Periotic and tympanic bulla.** (i) It is an irregularly shaped cartilaginous bone of auditory capsule and is composed of three ossifications (**pro**, **epi** and **opisthotic**). It is loosely fitted between squamosal and occipital ring. (ii) Periotic is differentiated into inner strong petrous portion enclosing membranous labyrinth, and outer porous mastoid portion produced into mastoid process. (iii) Tympanic bulla is a flask-shaped membrane bone, containing ear ossicles namely malleus, incus, and stapes.
- (12) **Premaxilla.** (i) Each premaxilla forms anteriormost part of upper jaw. It is elongated and united medially with the other. (ii) At its tip, it contains two **incisors** meant for food biting. (iii) Premaxilla also gives two processes posteriorly, namely dorsal processes which extends backwards up to frontal, and ventral nasal process which divides anterior palatine foramen into two lateral halves. It has nasal process.
- (13) **Maxilla.** (i) A pair of irregular maxillae constitutes major part of upper jaw, sides of face and orbits. (ii) Ventrally each maxilla contains six **sockets** for **molar** and **premolar** teeth and anteriorly a **maxillary process** which joins with premaxilla. (iii) From the mid-plane of each maxilla arises a horizontal palatine process, which meets its fellow process forming hard palate. (iv) Externally a strong **zygomatic process** originates which runs behind to meet jugal forming zygomatic arch. The latter forms below the boundary of the orbit.
- (14) **Jugal.** It is a laterally compressed bone forming major part of the **zygomatic arch**.
- (15) **Pterygoid.** It is a small and scale-like bone, attached vertically to the junction of palatine, alisphenoid and basisphenoid.
- (16) **Palatine.** (i) It is an irregularly-shaped bone on the mid-ventral region of skull. (ii) Anteriorly it forms part of hard palate and posteriorly it meets alisphenoid and pterygoid.

### 3. Disarticulated Skull Bones of *Varanus*

The disarticulated skull bones of *Varanus* include occipital region, basisphenoid, parietals, frontals, prefrontal, lacrymal, supraorbital, postfrontal, squamosal, quadrate, nasal, vomer, premaxilla, jugal, transverse, septomaxillary, palatine and pterygoid.

#### Comments :

- (1) **Occipital segment.** (i) It is posteriormost region of skull enclosing the large foramen magnum and composed of **supraoccipital**, **exoccipitals** and **basioccipital**. (ii) Supraoccipital is situated on the roof of cranium articulating with parietals and prootics. (iii) Basioccipital forms floor of the cranium, contains a rounded **occipital condyle** and articulates with basisphenoid, exoccipitals and prootics. (iv) Exoccipitals form lateral walls of cranium and articulate with supratemporal, squamosal, parietal and quadrate. Other structures seen are combined jugular and condyler foramen, foramen magnum, bulging of auditory capsules into cranial cavity and paraoccipitals process of exoccipital.
- (2) **Basisphenoid.** (i) It is a broad, flat and nearly rectangular bone, on the floor of cranium in front of basioccipital. (ii) Anteriorly, it contains a pair of **basipterygoid processes**, which articulate with pterygoids of respective sides, (iii) Between basipterygoids processes is a reduced knob-like process, which corresponds with parasphenoid of frog. (iv) Posteriorly, it articulates with basioccipital and is free laterally.
- (3) **Parietals.** The roof of cranial cavity in parietal region is formed by two completely fused parietals, which articulate with quadrates, squamosals, exoccipitals, postorbitals, prootics, supraoccipitals, exoccipitals and epipterygoids. It contains parietal foramen.

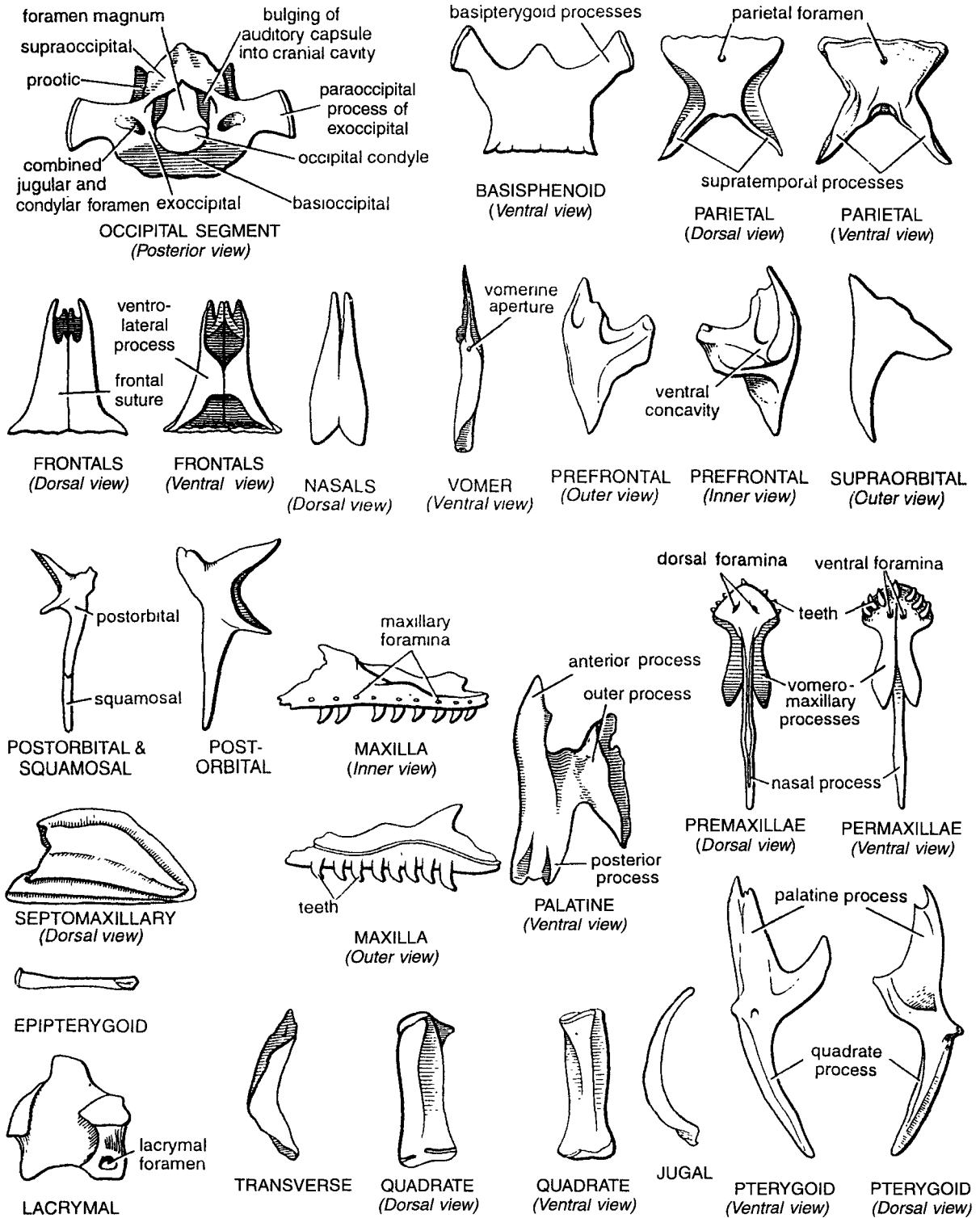

Fig. 11. Disarticulated skull bones of *Varanus*.

- (4) **Frontals.** (i) The roof of frontal cranium is formed by a pair of **ventro-lateral processes**, which are separated by **suture**. (ii) Due to the absence of sphenoid, the lateral side of frontal is free, while anteriorly it articulates with nasal, antero-laterally with prefrontal, posteriorly with postorbital, behind with parietal and beneath with parasphenoid.
- (5) **Prefrontal.** (i) It is a small and triangular bone between frontal and maxilla, (ii) Ventrally it contains a cup-like **ventral concavity** and it articulates with supraorbital and lacrymal.
- (6) **Lacrymal.** (i) It is a small bone found within margin of orbit and containing a small opening for the lacrymal duct. (ii) It articulates with maxilla in front, with jugal behind and with prefrontal above.
- (7) **Supraorbital.** (i) It is a small anchor-shaped bone found at the anterior portion of orbit. (ii) Its broad base articulates with prefrontal.
- (8) **Postorbital or postfrontal.** (i) It forms postero-dorsal boundary of orbit behind frontal. (ii) It has four processes. Two inner processes articulate with parietal and frontal. The long posterior process articulates with squamosal, while fourth short process remains free.
- (9) **Squamosal.** (i) It is a rod-shaped bone, forming posterior portion of supratemporal arcade. (ii) Anteriorly, it articulates with postorbital while posteriorly with quadrate, supratemporal, parietal and exoccipital. (iii) Its lower end articulates with articular bone of lower jaw.
- (10) **Quadrate,** (i) It is a stout rod-shaped bone, obliquely attached to postero-lateral side of cranium, (ii) It helps in suspensorium. (iii) Upper end articulates with squamosal, supratemporal, parietal and exoccipital. (iv) Lower end articulates with articular bone of lower jaw.
- (11) **Nasals,** (i) A pair of nasal bones are fused medially forming roof of olfactory chambers. (ii) Its anterior narrow part articulates with nasal process of premaxilla and **septomaxillary**.
- (12) **Vomers.** (i) There are two vomers forming anterior roof of mouth and inner margins of posterior nares. (ii) Each vomer is perforated centrally by a vomerine aperture. (iii) Vomers are fused anteriorly and separated posteriorly. (iv) Anteriorly, they articulate with premaxillae and maxillae while posteriorly with palatines.
- (13) **Premaxillae.** (i) The two premaxillae are fused together, forming the anterior extremity of upper jaw. (ii) Dorsally it contains a pair of premaxillary foramina, ventrally it has 6 to 8 small teeth and posteriorly it gives three processes, namely a dorsal process articulating with nasals and two ventral processes articulating with vomers and maxillae.
- (14) **Maxilla.** (i) A maxilla forms anterior half of upper jaw on either side. (ii) It contains 8 to 10 small, conical and curved, pleurodont teeth and several small maxillary foramina. (iii) Maxilla articulates with palatine, premaxilla, prefrontal, supraorbital, lacrymal, jugal and transverse.
- (15) **Jugal.** (i) It is a slender bone constituting ventrally outer boundary of orbit. (ii) Anteriorly, it articulates with maxilla and lacrymal, inwardly with transverse and remains free posteriorly.
- (16) **Transverse.** It is found internal to jugal extending backwards to form floor of orbit.
- (17) **Septomaxillary.** (i) It is an irregularly-shaped bone above vomers in nasal region, (ii) It articulates with maxilla and premaxilla anteriorly and with nasal posteriorly.
- (18) **Palatine.** (i) Each palatine is a small irregularly flattened bone forming roof of buccal cavity and posterior boundary of inner nare. (ii) It has three processes; anterior process articulates with vomer, posterior with pterygoid and outer with maxilla and transverse.
- (19) **Pterygoid.** (i) A pair of pterygoid bones also forms roof of mouth. They are of irregular shape containing three processes; **anterior palatine processes** articulate with palatine and transverse and posterior process with basipterygoid and quadrate called as quadrate process. (ii) A slender epipterygoid bone extends between pterygoid and prootic.

### 4. Disarticulated Skull Bones of Fowl

The disarticulated skull bones of fowl consist of occipital segment, premaxilla, maxilla, jugal, quadrato-jugal, quadrate, nasal, lacrymal, pterygoid and palatine.

**Comments :**

- (1) **Occipital segment.** (i) It is the posteriormost region of skull, containing a large **foramen magnum** and is composed of **basioccipital**, **exoccipitals** and **supraoccipital**. (ii) Beneath foramen magnum is a single occipital condyle. Other structures seen are **occipital** foramen external acoustic meatus, paramastoid process, basioccipital, foramen for spinal accessory nerve, foramen magnum, external occipital and protuberance.
- (2) **Premaxillae.** (i) Two premaxillaries are completely fused together forming anteriormost region of upper jaw and entire upper beak. (ii) Each premaxilla contains three processes; **nasal process** ascends to join with frontal forming boundary of external nare, **maxillary process** extends backwards and outwards to join with maxilla and palatine process, joins with palatine to form palate. Other structures seen are median ridge, palatine foramen and lateral ridge.
- (3) **Maxilla.** (i) It is a rod-shaped bone of anterior upper jaw. (ii) Anteriorly it articulates with premaxilla and nasal and is expanded into laminated spongy horizontal **maxillopalatine process** which articulates with palatine ventrally. (iii) Posteriorly the **posterior process** of maxilla constitutes anterior part of suborbital bar.
- (4) **Jugal.** It is a rod-shaped bone forming middle region of suborbital bar and is found dorsal to maxilla and quadratojugal.

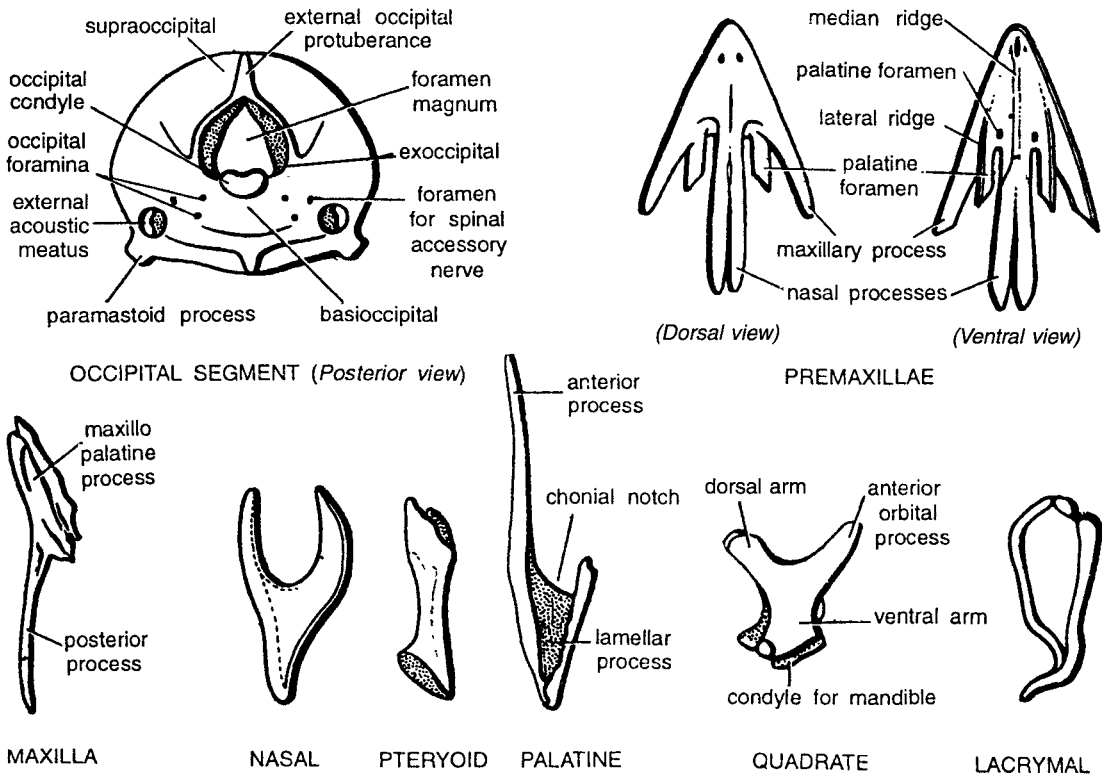

Fig. 12. Disarticulated skull bones of Fowl.



- (5) **Quadratojugal.** It forms posteriormost part of **suborbital bar** and is thickened posteriorly to articulate with quadrate.
- (6) **Quadrate.** (i) It is a tough triradiate bone, situated in front of tympanic cavity. (ii) It takes part in suspensorium. (iii) It has three arms; anterior orbital arm extends above pterygoid and terminates freely, **dorsal arm** is movable and articulated with squamosal, **ventral arm** gives rise to **condyle** which articulates with mandible.
- (7) **Nasal.** (i) The nasals form sides and roof of olfactory chambers and are separated by nasal processes of premaxilla. (ii) Each nasal is a thin triangular plate-like bone having three processes; two anterior processes form posterior boundary of external nare and join premaxillary processes, posterior process articulates with frontal and lacrymal.
- (8) **Lacrymal.** (i) A pair of lacrymals forms anterior boundary of orbits. (ii) It contains a curved process and a characteristic foramen.
- (9) **Pterygoid.** (i) A pair of pterygoids forms posterior boundary of mouth cavity, (ii) Each pterygoid articulates with inner surface of ventral arm of quadrate and in front with palatine and parasphenoid rostrum of its side.
- (10) **Palatine,** (i) It is a slender and rod-shaped bone forming inner arcade of upper jaw. (ii) Anteriorly palatine joins with maxillary and premaxillary processes and it movably articulates with pterygoid. (iii) Posterior end is broadened to articulate with parasphenoid rostrum. Structure seen are anterior process. Chonial notch and lamellar process.

## LOWER JAWS OR MANDIBLES

### 1. Lower Jaw or Mandible of Frog

#### Comments :

The lower jaw of frog is devoid of teeth and the **mandible consists** of **Mento-meckelian, dentary, angulosplenic** coronary process and articular facet for quadrate.

- (1) **Mento-meckelian.** (i) The anterior extremity of **Meckel's cartilage** becomes ossified forming a small cartilage bone called **Mento-meckelian**. (ii) It is found at anterior symphysis of mandibles.
- (2) **Angulo-splenic.** (i) It is a long, curved lower jaw bone, forming major part of posterior region of each mandible. (ii) It has a small projection called the **coronary process**. (iii) Its anterior end is pointed, while posterior end contains an **articular surface** for quadrate cartilage.
- (3) **Dentary.** (i) It is closely applied anteriorly to angulo-splenic and is a dagger-shaped bone. (ii) It extends up to Mento-meckelian bone. It is dagger shaped both in outer and inner.

### 2. Lower Jaw or Mandible of *Varanus*

#### Comments :

[I] Mandible in inner view comprises of following parts

- (1) **Articular.** (i) It is the posteriormost bone of the lower jaw ramus, articulating with quadrate dorsally. (ii) It extends behind angular process which terminates into articular cartilage.
- (2) **Angular.** (i) Small splint-like bone, found between dentary and articular. (ii) Perforated by **angular foramen**.
- (3) **Supra-angular.** It is an elongated, nearly rectangular bone, found in the middle of each ramus and contains a pair of **mandibular foramina**.

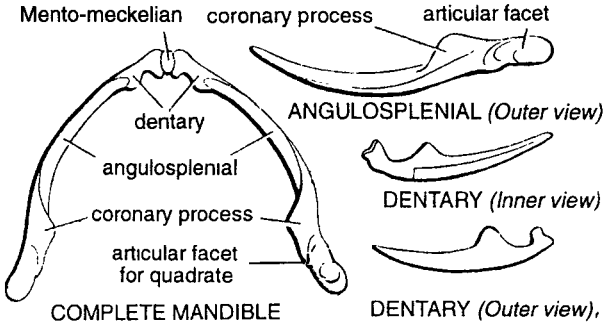

Fig. 13. Mandible of Frog.

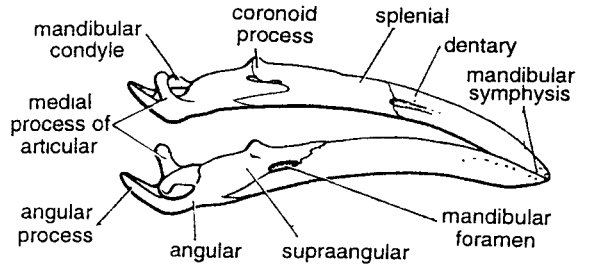

Fig. 14. Mandible of Fowl.

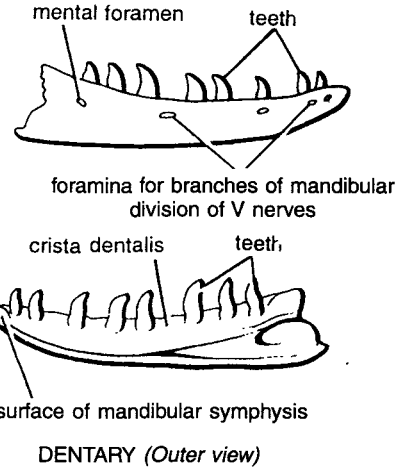
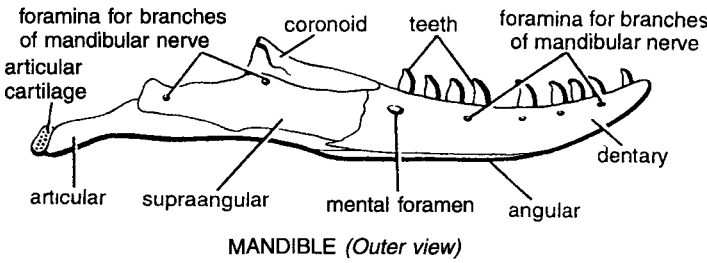

Fig. 15. Mandible of *Varanus*.

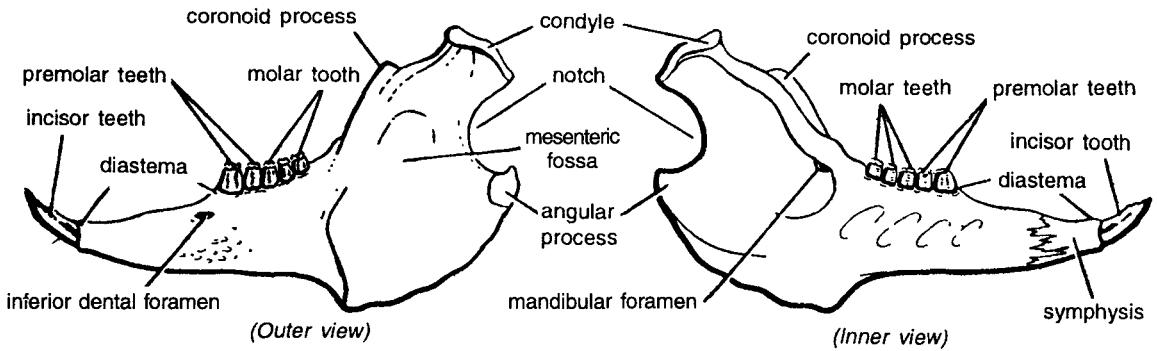

Fig. 16. Mandible of Rabbit.

- (4) **Coronoid.** It is a small process constituting dorsal side of middle ramus and gives rise to backwardly directed coronoid process.
- (5) **Splenial.** It is a membranous bone in a groove on the inner side of dentary.

### [III] Mandible (Outer view)

- (6) Mandible (outer view) consists of, foramina for branches of mandibular nerve, a tests, coronoid, foramina for branches of mandibular nerve, articular cartilages articular suprangular, mental foramen angular and dentary.
- (7) **Dentary.** It forms major part of lower jaw ramus and contains 8 to 10 small, conical, pleurodont teeth, along dorsal edge in inner view. While dentary in outer view consists of 8 teeth, mental form and foramina for branches of mandibular divisions of V nerves.

## 3. Lower Jaw or Mandible of Fowl

### Comments :

The lower jaw of fowl is devoid of teeth. Each ramus is made of the following bones :

- (1) **Articular.** (i) It expands from posterior end of each ramus and is continued with Meckel's cartilage, (ii) It contains **mandibular condyle** dorsally.
- (2) **Angular.** It lies below articular and forms lower border of jaw.
- (3) **Supra-angular.** It forms upper margin of posterior mandible and contains a small **coronoid process**.
- (4) **Splenial.** It is a thin bone found along the inner surface of middle of mandible.
- (5) **Dentary.** (i) It forms anterior half of mandible and joins with fellow dentary at an **anterior symphysis**. (ii) It is devoid of teeth and contains a **mandibular foramen**.

## 4. Lower Jaw or Mandible of Rabbit

### Comments :

In rabbit, the lower jaw of each side is made of a single dentary bone. The two dentaries are joined together at a mandibular symphysis.

### [I] Mandible (Outer view)

- (1) Postero-lateral surface contains large mesenteric fossa for attachment of masseter muscle.
- (2) Condyle and angle are separated by a deep notch posteriorly.
- (3) Teeth are incisor, premolars and molars.
- (4) Several processes such as condyle, angular process and coronoid process present.

### [II] Mandible (Inner view)

Consists of incisor tooth, diastema, premolar teeth, molar teeth, coronoid process, condyle, angular process and mandibular foramen.

# BONES OF VERTEBRAL COLUMN

## 1. Vertebrae of Frog

**Comments :**

- (1) **Atlas (Dorsal view).** (i) It is a ring-shaped bone with reduced **centrum** on one face only. (ii) Anteriorly centrum contains two large concave facets for articulation with **occipital condyles**. (iii) **Pre-zygapophyses** absent, neural spine reduced, **post-zygapophyses** present and neural arch present.
- (2) **Atlas vertebra (Ventral view).** It shows neural canal, post-zygapophysis centrum and anterior facet for occipital condyle.
- (3) **Typical vertebra-2nd to 7th (Lateral view).** (i) It is a typical vertebra. (ii) It is also nearly a ring-shaped bone. (iii) **Centrum procoelous** with anterior **concave face** and **posterior convex** faces. (iv) **Neural spine** is **blunt** and **transverse processes** are long and tapering on their side of centrum. (v) **Pre-zygapophyses** (pre-zygp) are inwardly and upwardly directed, while **post-zygapophyses** (post-zygp) are downwardly and outwardly directed. (vi) The **second vertebra** is like other typical vertebrae except that its neural spine is short and transverse processes broad.

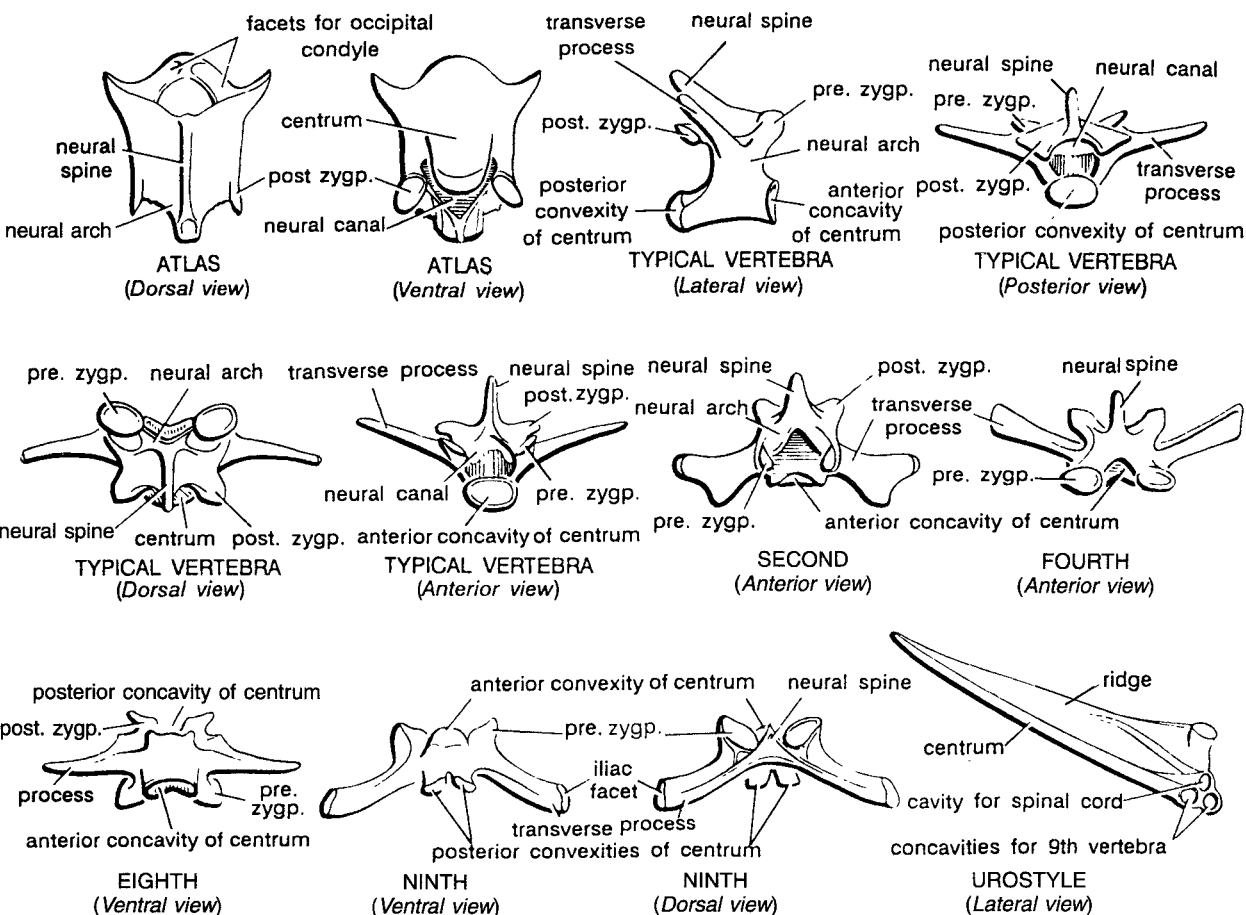

Fig. 17. Vertebrae of Frog.

- (4) **Typical vertebra (Posterior view)**. It shows **neural spine, neural canal, pre-zygapophysis transverse processes** and post-zygapophysis.
- (5) **Typical vertebra (Dorsal view)**. Structures seen are **pre-zygapophysis, neural arch, post zygapophysis centrum** and **neural spine**.
- (6) **Typical vertebra (Anterior view)**. It has transverse process, neural spine, post-zygapophysis, pre-zygapophysis, anterior concavity of centrum and neural canal.
- (7) **Second vertebra (Anterior view)**. Structures seen are neural spine, post-zygapophysis, transverse process, anterior concavity of centrum pre-zygapophysis and neural arch.
- (8) **Fourth vertebra (Anterior view)**. It shows neural spine, transverse process, anterior concavity of centrum and pre-zygapophysis.
- (9) **Eighth vertebra (Ventral view)**. (i) Centrum in **amphicoelus** or biconcave. (ii) Anterior part of centrum receives **posterior concavity** of seventh vertebra and **posterior part** receives **anterior convexity** of ninth vertebra. (iii) Other structures are transverse processes, pre-zygapophysis and post-zygapophysis.
- (10) **Ninth vertebra (Ventral view)**. It has anterior convexity of centrum, pre-zygapophysis, iliac facet, transverse process and posterior convexity of centrum.
- (11) **Ninth vertebra (Dorsal view)**. Structures seen are neural spine, pre-zygapophysis, iliac facet, transverse process and posterior convexity of centrum.
- (12) **Urostyle**. (i) It is the last part of vertebral column and quite elongated. (ii) **Centrum** is rod-shaped which contains two **concavities anteriorly** for articulation with the ninth vertebra, and a **cavity** for the terminal part of the spinal cord.

## 2. Vertebrae of *Varanus*

### Comments :

- (1) **Atlas (Anterior view)**. (i) It is also a ring-shaped bone, composed of three pieces, two **dorso-lateral** and one ventral. (ii) **Centrum** and transverse processes are absent. (iii) During living condition, the **neural canal** is divided into **dorsal** and **ventral** neural canals by a **ligament**. (iv) It contains anterior **concavity** for **occipital condyle**.
- (2) **Atlas (Posterior view)**. Structures seen are **dorso-lateral piece, dorsal neural canal, ligament, ventral neural canal** and facet for odontoid process.
- (3) **Axis (Lateral view)**. (i) It is the **second cervical** vertebra. (ii) Transverse processes are absent. (ii) **Pre-zygapophyses** reduced, while **post-zygapophyses** well developed. (iv) **Neural spine large** and crest-like (v) **Centrum** contains a spine-like process below **odontoid process** and a hypapophysis.
- (4) **Typical cervical (Lateral view)**. (i) **Centrum** elongated and strongly procoelous. (ii) It contains a ventral backwardly-directed **hypapophysis**. (iii) Neural spine is crest-like. (iv) **Neural arch** contains a pair of anterior upwardly-directed **pre-zygapophyses** and a pair of posterior backwardly-directed **post-zygapophyses**. (v) Behind third vertebra, each cervical contains a pair of lateral facets for articulation of ribs.
- (5) **Thoraco-lumber (Lateral view)**. (i) They are larger than cervical with strongly **procoelous centrum** and well developed **pre- and post-zygapophyses**. (ii) Hypapophysis absent. (iii) At the junction of neural arch and centrum a distinct capitular facet is present to articulate with rib.
- (6) **Thoracolumber (Dorsal view)**. Structure seen are neural arch, pre-zygapophysis, capitular facet for rib, neural spine, post-zygapophysis and centrum.
- (7) **First sacral**. (i) It supports pelvic girdle. (ii) **Centrum** is procoelous. (iii) **Pre- and post-zygapophyses** well developed. (iv) **Neural spine** slightly crest-like. (v) Transverse processes greatly expanded and notched to articulate with ilia.

Table 3. Vertebrae of four Vertebrate Types.

Frog	Varanus	Fowl	Rabbit
1. Atlas	1. Atlas	1. Atlas	1. Atlas
2. Typical (2-7)	2. Axis	2. Axis	3. Axis
3. 8th vertebra	3. Typical cervical	3. Typical cervical	3. Typical cervical
4. 9th vertebra	4. Thoraco-lumber	4. Fused thoracic	4. Anterior thoracic
5. Urostyle	5. First sacral	5. Free thoracic	5. Posterior thoracic
	6. Second sacral	6. Synsacrum	6. Anterior lumbar
	7. Anterior caudal	7. Free caudal	7. Posterior lumbar
		8. Pygostyle	8. Sacrum
			9. Caudal

(8) **Second sacral (Lateral view).** (i) It resembles first sacral in having procoelous centrum, low crest-like neural spine neural notch and well-developed pre- and post-zygapophyses. (ii) It differs from first sacral in the absence of a notch in transverse processes.

(9) **Anterior caudal.** (i) It is like sacral superficially, but it contains a **long centrum**, slender **neural spine** and **transverse processes** and fairly developed pre- and post-zygapophyses. (ii) Specific feature of the vertebra is the presence of a Y-shaped **chevron bone** beneath centrum.

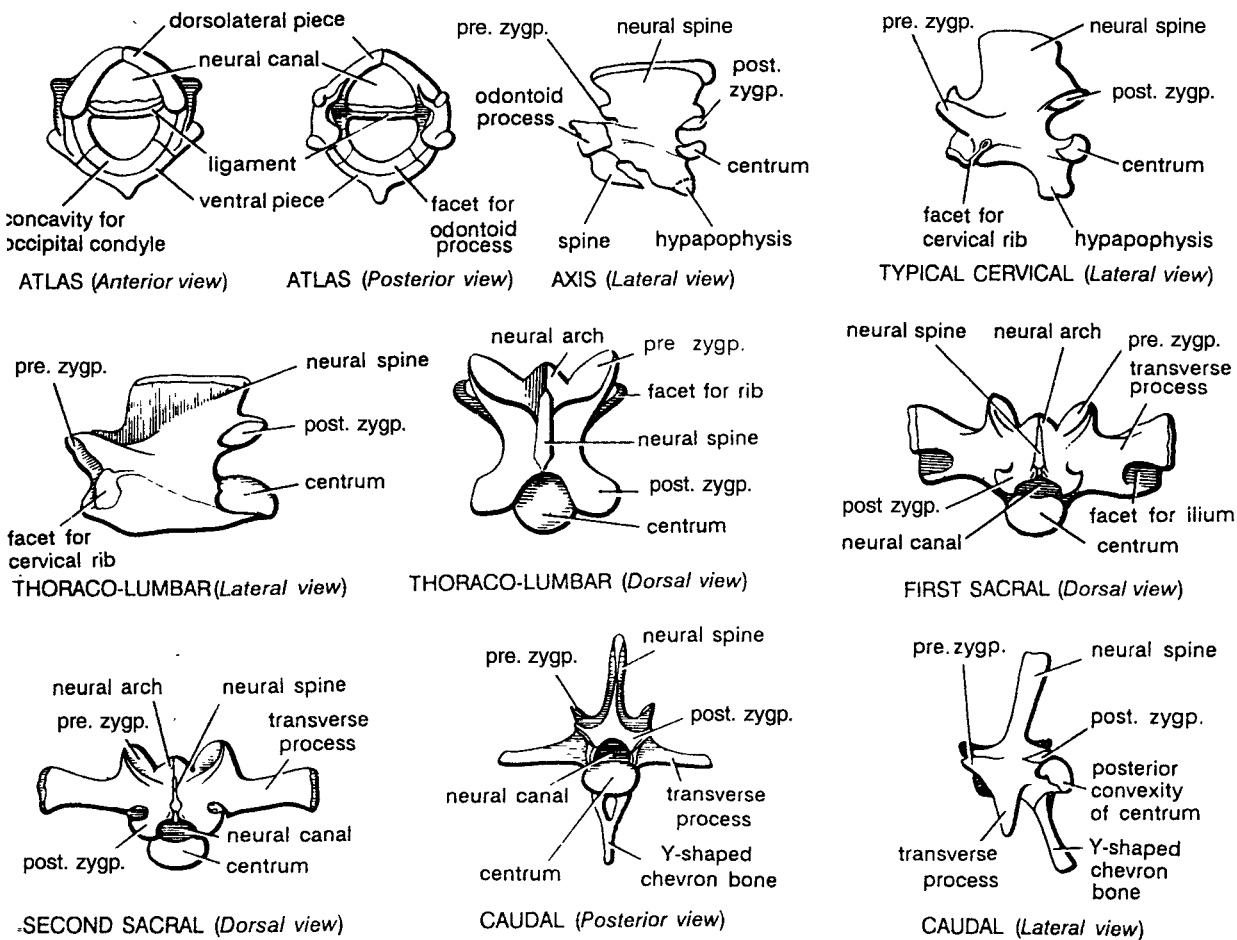

Fig. 18. Vertebrae of Varanus.

### 3. Vertebrae of Fowl

#### Comments :

- (1) **Atlas.** (i) Atlas or first cervical is ring-shaped, roughly triangular bone, composed of two dorso-lateral and one ventral pieces. (ii) Concavity for occipital condyle and a notch for odontoid process. (iii) Centrum, neural spine, ribs, transverse processes and pre-zygapophyses are absent.
- (2) **Atlas (Ventral view).** Structures seen are **post-zygapophyses, neural canal, ventral piece**, cavity for occipital condyle and facet for **odontoid process**.
- (3) **Axis or epistropheus.** (i) It is also called as second cervical which is without transverse processes, ribs and vertebral canals. (ii) Neural spine, pre-zygapophyses and post-zygapophyses present. (iii) Centrum heterocoelous and produced into an anterior odontoid process.
- (4) **Typical cervical (Dorsal view).** (i) 14 in number. (ii) Centrum heterocoelous. (iii) Neural arch short and neural spine rudimentary. (iv) Transverse processes short and irregular and fused with thin, backwardly directed reduced cervical ribs. (v) Pre-zygapophyses flat while post-zygapophyses project downwards and outwards.
- (5) **Typical cervical (Ventral view).** Structures seen are **heterocoelous centrum, transverse process, cervical rib** and **post-zygapophyses**.  
**Fused thoracic.** (i) Second to fifth 7 thoracic vertebrae are fused. (ii) Due to complete fusion, neural spines, transverse processes and hypapophyses look like plates which are perforated by intervertebral gaps.
- (6) **Free thoracic.** (i) First and sixth thoracic vertebrae are free. (ii) Each vertebra has heterocoelous centrum, hypapophysis and it also carries double-headed thoracic ribs.
- (7) **Posterior cervical (Anterior view).** Structures seen are neural spine, **neural canal**, transverse hypophysis, **heterocoelus centrum**, vertebral enterial foramen, pre-zygapophysis neural arch and post-zygapophysis.
- (8) **Free thoracic (Anterior view).** (i) First and sixth vertebral are free. (ii) Each vertebrae contains **neural arch, post-zygapophysis, pre-zygapophysis, hypophysis, heterocoelus centrum transverse process**, neural canal and neural spine.
- (9) **Fused thoracic (Lateral view).** (i) Second, third, fourth, fifth and seventh vertebrae are fused together. (ii) Due to complete fusion, neural spines, transverse processes and hypophysis look like plates which are perforated by intervertebral gap.
- (10) **Synsacrum (Dorsal view).** (i) **Synsacrum** in formed by last thoracic, 6 lumber, 2 sacral and 7 caudal vertebrae. (ii) Thoracic vertebrae contain a pair of thoracic ribs. (iii) Lumber vertebrae are firmly fused together with free transverse process and without hypophysis. (iv) Sacral vertebral fused together to form bony plate. (v) Other structures seen are pre-zygapophysis centrum, fused neural spine and caudal vertebra.
- (11) **Synsacrum (Ventral view).** Structures seen are pre-zygapophysis, thoracic vertebra, transverse process, lumber vertebra, fused transverse process of sacral vertebrae and bifurcated transverse processes and caudal vertebra.
- (12) **Free caudal.** It has bifurcated neural spine, neural canal, centrum and transverse process.
- (13) **Pygostyle.** It shows upper surface and fused caudal vertebrae.

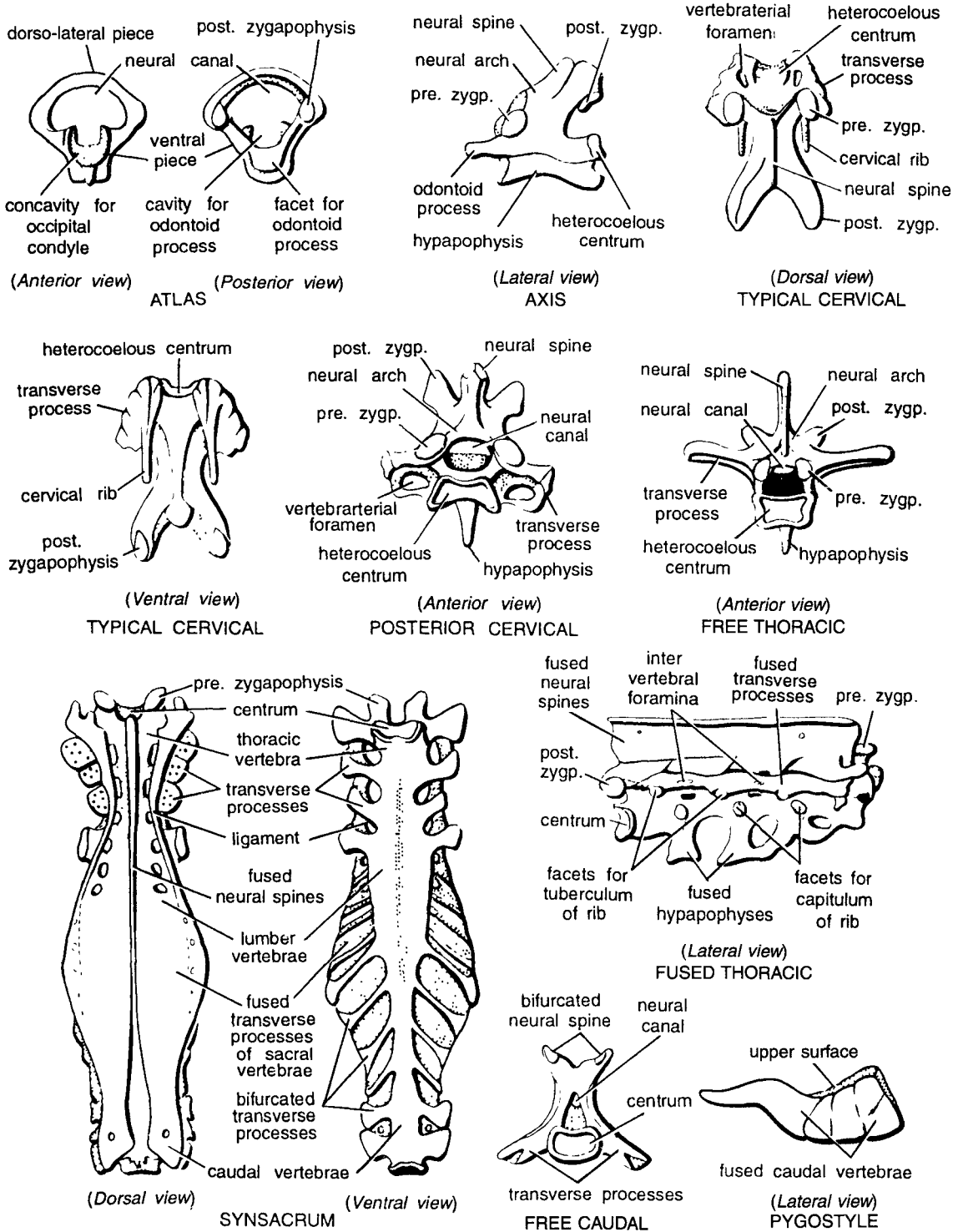

Fig. 19. Vertebrae of Fowl.



## 4. Vertebrae of Rabbit

### Comments :

- (1) **Atlas.** (i) It is first cervical and signet-ring like. (ii) Centrum, zygapophyses absent and neural spine rudimentary. (iii) On the sides are present flattened cervical ribs, the so-called transverse processes.
- (2) **Atlas (Anterior view).** (i) It has 2 anterior facets feroccipital condyle, (ii) Other structures are **neural spine, neural canal, vertebral arterial canal, transverse process and neural arch.**
- (3) **Atlas (Posterior view).** (i) Posteriorly it has facets for odontoid processes and articular facet for axis. (ii) Other structures are neural arch, neural spine, neural canal and vertebrarterial canal. (iii) During living condition neural canal is divided into dorsal and ventral parts by a ligament.
- (4) **Axis (Lateral view).** (i) It is second cervical. (ii) **Neural spine** is flattened, antero-posteriorly elongated and ridge-like. (iii) Cervical ribs or so-called transverse processes are small. (iv) **Centrum** contains peg-like **odontoid** process. (v) Pre-zygapophyses absent. Other structures are neural arch, articular surface for atlas and post-zygapophysis.
- (5) **Typical cervical (Anterior view).** (i) Rest of the cervicals are typical having small **neural spine, large neural arch, flattened centrum, pre-zygapophyses and post-zygapophyses.** (ii) **Transverse process** bifurcated and perforated by a vertebrarterial canal and facet for cervical rib present.
- (6) **Anterior thoracic (Anterior view).** (i) It contains a backwardly-oriented neural spine. (ii) Neural arch has upwardly-directed **pre-zygapophyses** and downwardly-directed **post-zygapophyses.** (iii) **Transverse processes** short and contain facets for **tuberculum of ribs.** (iv) **Centrum** short.
- (7) **Anterior thoracic (Lateral view).** Structures seen are long tilted neural spine, facets of tuberculum of rib post-zygapophysis, centrum, post-zygapophysis, intervertebral notch, centrum and pre-zygapophysis.
- (8) **Posterior thoracic (Lateral view).** (i) Last 4 or 5 thoracic vertebrae differ from anterior ones in having a **long centrum, short neural spine, distinct zygapophyses** and reduced **transverse processes.** (ii) It contains capitular facets, **metapophyses** and **anapophyses.** It has invertebral notch.
- (9) **Anterior lumbar (Anterior view).** (i) Out of 7, first two called as anterior lumbar vertebrae. (ii) Neural arch on either side contains an anteriorly-directed process called metapophysis which bears pre-zygapophysis, and a posteriorly and backwardly-directed anapophysis which bears post-zygapophysis. Hypophysis present.
- (10) **Posterior lumbar (Lateral view).** (i) 3rd to 7th vertebrae are called as posterior lumbar. (ii) The resemble anterior lumbar in all respects except that a ridge-like hypapophysis is present below centrum.
- (11) **Sacrum (Lateral view).** (i) Sacral vertebrae (4 in number) are fused to form a compact bone supporting pelvis. (ii) The neural spines, zygapophyses and intervertebral foramina are peculiar.
- (12) **Sacrum (Dorsal view).** Structures seen as neural spine, post-zygapophyses intervertebral foramen, 1st sacral vertebra, centrum, pre-zygapophysis and articular facet for ilium.
- (13) **Caudal (Dorsal view).** Structures seen, are neural spines, vertebral, post-zygapophysis, and pre-zygapophysis.

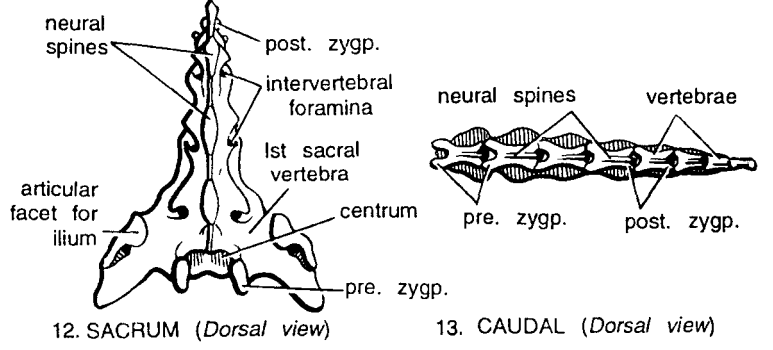
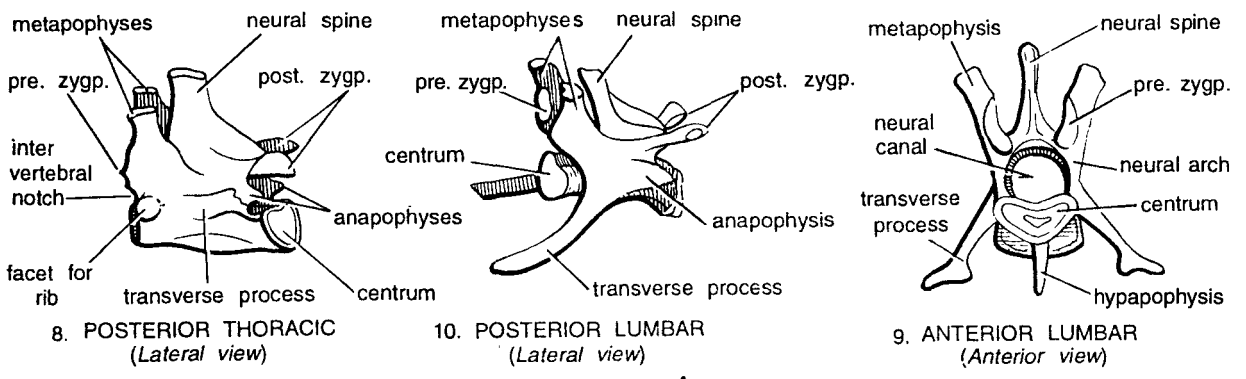
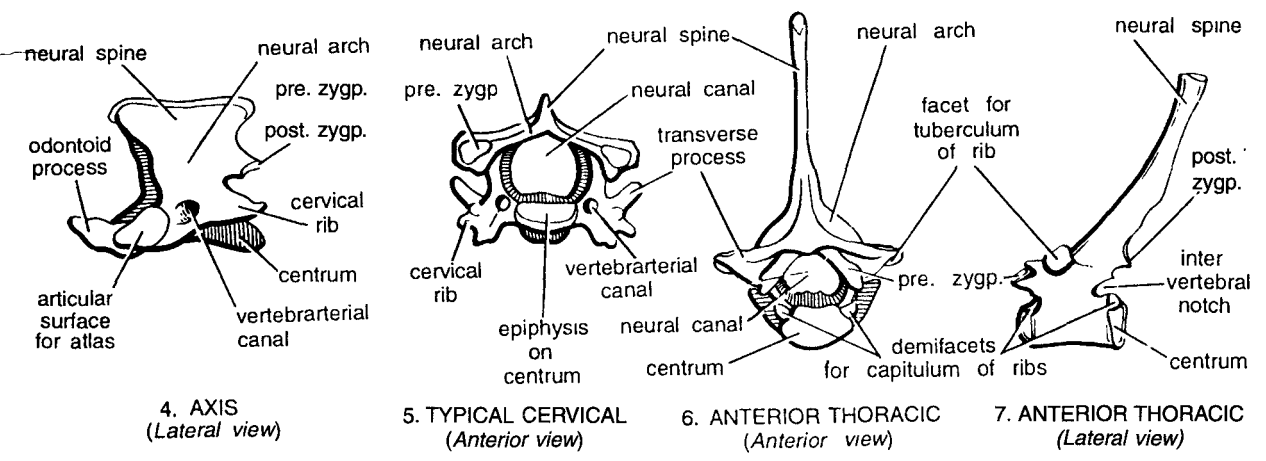
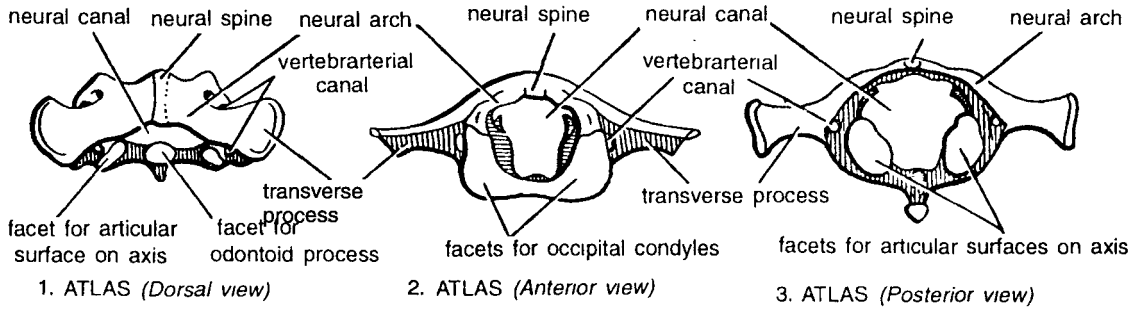

Fig. 20. Vertebrae of Rabbit.

Table 4. Comparison of Sterna of Vertebrate.

Frog	Varanus	Fowl	Rabbit
1. <b>Sternum</b> of frog is fused between two halves of pectoral girdle 2. It is composed of the following four parts : (a) <b>Episternum</b> . It is a cartilaginous flat disc, anteriorly situated, forming head of Comosternum. (b) <b>Omosternum</b> . It is bifurcated behind and connects clavicles, below clavicle is precoracoid, coracoid and epicoracoid. (c) <b>Mesosternum</b> . It is a cartilaginous rod projecting behind epicoracoids. (d) <b>Xiphisternum</b> . It is the cartilaginous head of mesosternum.	1. <b>Sternum</b> of <i>Varanus</i> is in the form of a rhomboidal calcified cartilaginous plate. 2. Antero-laterally it articulates with coracoids and epicoracoids of pectoral girdle. 3. Posteriorly it bears three notches for sternal ribs. 4. It is attached with a T-shaped interclavicle.	1. <b>Sternum of fowl</b> is well developed and called breast bone. 2. It is boat-shaped and composed of the following structures— (a) <b>Metasternum</b> . Main part, concave dorsally and convex ventrally. (b) <b>Manubrium</b> . Antero-ventral vertical process of metasternum processes. (c) <b>Keel</b> . Median sagittal ridge from ventral surface of metasternum. (d) <b>Metasternal processes</b> . Anterior coastal processes and posterior metostea of xiphoid.	1. <b>Sternum of rabbit</b> is segmented, consisting of 7 cylindrical bones embedded in the thoracic wall. 2. First bone is called <b>manubrium</b> , 2nd to 6th called <b>sternebrae</b> , and last called <b>xiphisternum</b> which bears a cup-shaped <b>xiphoid cartilage</b> . 3. Costal bones and sternal ribs present.

## RIBS

### 1. Thoracic Rib of *Varanus*

#### Comments :

All the thoracic vertebrae bear one pair of thoracic ribs. They are slender, curved rods of bone and cartilage. Each rib is differentiated into a dorsal bony **vertebral portion** and ventral cartilaginous **sternal portion**. Ribs are unicephalous or single-headed, that is, the vertebral end bears a single facet, or **capitulum**, which articulates with the centrum of the vertebra. The sternal parts of the anterior three thoracic ribs reach ventrally to join the **sternal plate**.

### 2. Thoracic Rib of Fowl

#### Comments :

There are 7 pairs of thoracic ribs in fowl, one pair articulating with each thoracic vertebra. Normally each rib is made of a dorsal **vertebral portion** and a ventral **sternal portion**. The **vertebral end** is **bicephalous**, that is consisting of two heads, a **capitulum** for the centrum and a **tuberculum** for the transverse process of the thoracic vertebra. The vertebral part bears a prominent backwardly-directed **uncinate process**, which overlaps the next rib behind and is characteristic of birds.

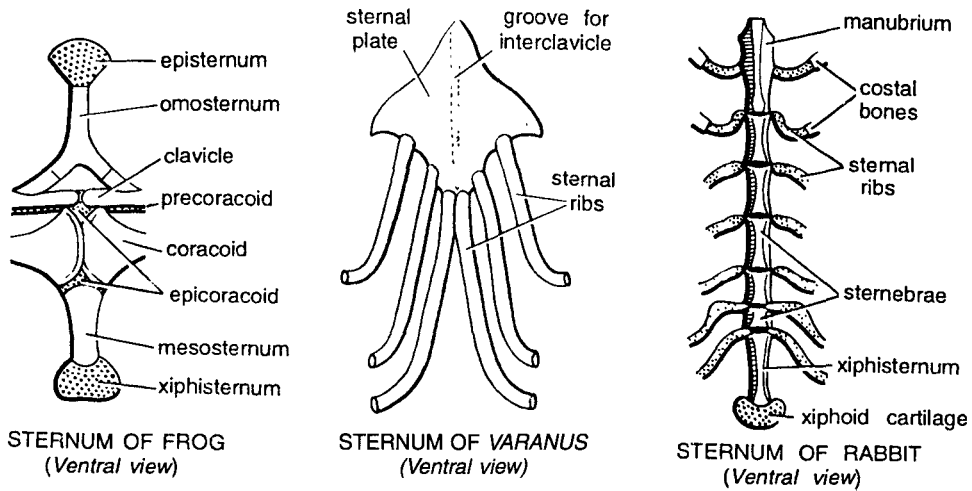

Fig. 21. Sternum of Frog *Varanus* and Rabbit.

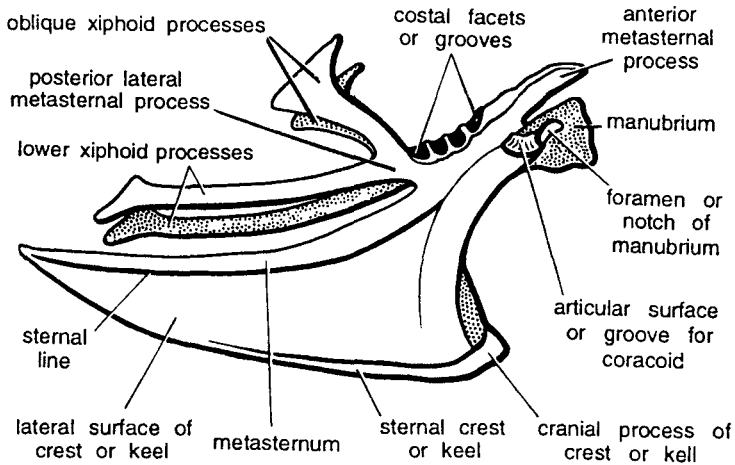

Fig. 22. Sternum of Fowl.

### 3. Thoracic Rib of Rabbit

**Comments :**

The thoracic vertebrae carry each one pair of thoracic ribs. The ribs are slender, curved and each differentiated into dorsal bony **vertebral portion** and a ventral cartilaginous **sternal portion**. The vertebral end is bicephalous or two-headed, bearing two facets, the **capitulum** and the **tuberculum**, articulating with the centrum and transverse process of the thoracic vertebra, respectively.

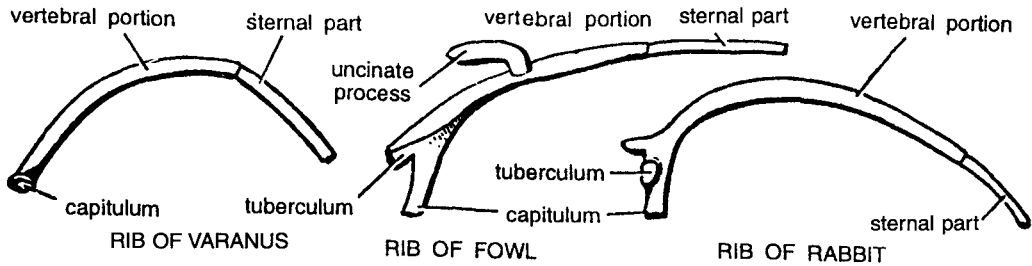

Fig. 23. Thoracic ribs of *Varanus*, Fowl and Rabbit.

## PECTORAL GIRDLES

### 1. Pectoral Girdle and Sternum of Frog

#### Comments :

- (1) Pectoral girdle is found embedded in the body wall in thoracic region. It is composed of two identical halves which are permanently attached with sternum (Fig. 24).
- (2) Each half is composed of **scapular** and **coracoid** regions.
- (3) **Scapular** region consists of **suprascapula** and **scapula**. Suprascapula is a broad, flat and rectangular bone having free calcified cartilaginous margin. Scapula is also flat and contains a cup-like **glenoid cavity** for humerus.
- (4) **Coracoid** region is made up of two bones, namely **clavicle** and **coracoid**, and two cartilages viz. **epicoracoid** and **precoracoid**.
- (5) Pectoral girdle protects viscera and gives support to limbs. Other structures seen regarding sternum are episternum, **omosternum** **xiphisternum** and **mesosternum**.

### 2. Pectoral Girdle of *Varanus*

#### Comments :

- (1) Pectoral girdle of *Varanus* is also made up of two identical halves, firmly attached with a T-shaped **interclavicle** or **episternum** (Fig. 24).
- (2) Each half is composed of **suprascapula**, **scapula**, **coracoid**, **interclavicle** and **clavicle**.
- (3) **Suprascapula**. It is flattened, calcified and cartilaginous plate, articulating ventrally with scapula. Its dorsal margin is free and curved.
- (4) **Scapula**. It is completely ossified, flattened and unfenestrated plate, articulating with suprascapula and coracoid.
- (5) **Coracoid**. It is a flat bone partly ossified and partly cartilaginous. It contains two large fenestrae, which divide ossified region into three parts, namely **anterior procoracoid**, **middle mesocoracoid** and **posterior broad coracoid proper**. Inner end of coracoid lying over fenestrae is cartilaginous and termed epicoracoid. At the posterior junction of scapula and coracoid is a cup-shaped **glenoid cavity** for the head of humerus.
- (6) **Interclavicle or episternum**. T-shaped investing bone between two halves.
- (7) **Clavicle**. Short, curved dermal bone, articulating with suprascapula and interclavicle.

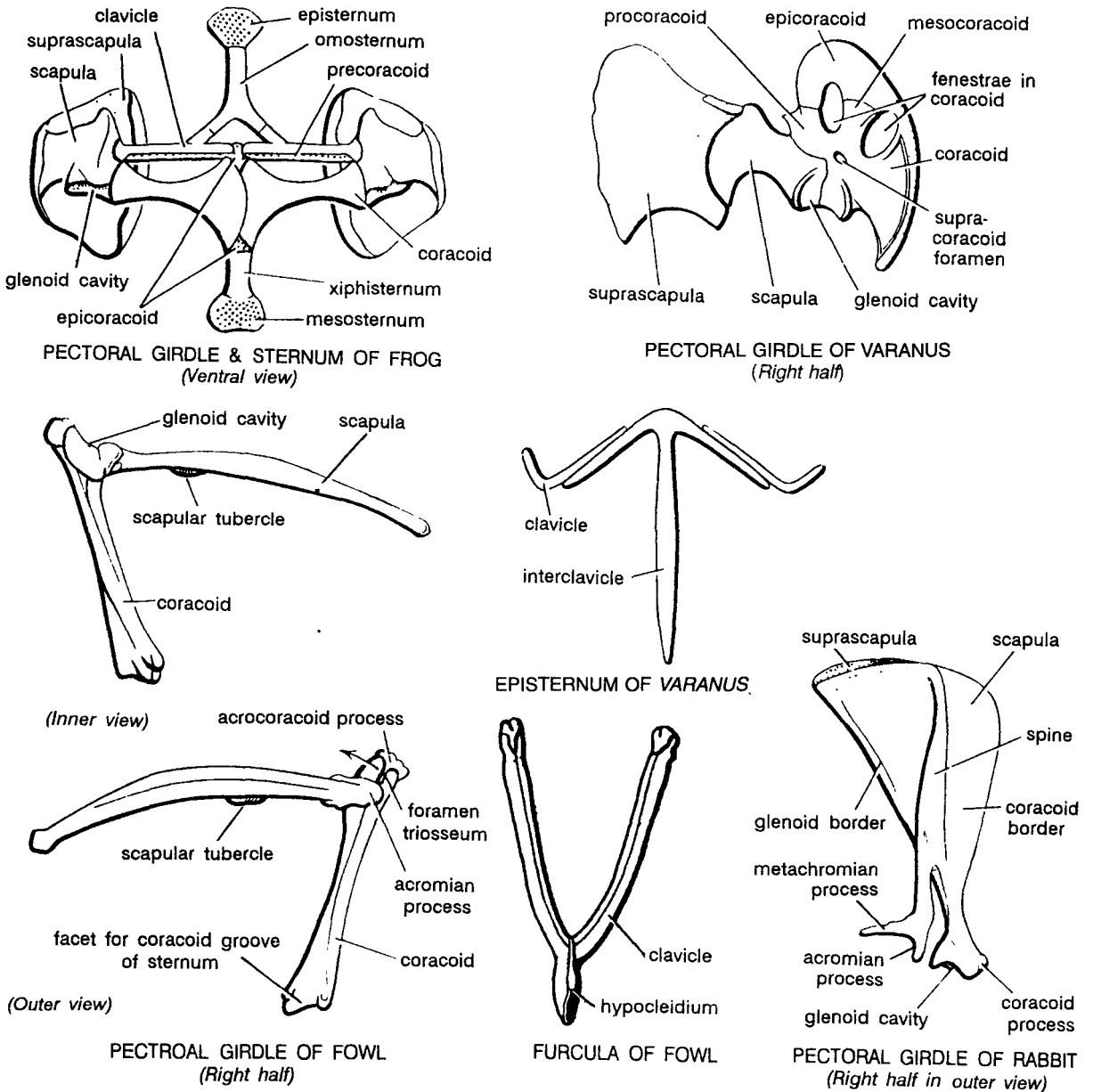

Fig. 24. Pectoral girdle of Frog, *Varanus*, Fowl and Rabbit.

### 3. Pectoral Girdle of Fowl

**Comments :**

- (1) Pectoral girdle is peculiarly inverted L-shaped (7) and composed of **coracoid**, **scapula** and **clavicle**.
- (2) **Coracoid.** (i) It is a large, stout and rod-shaped bone. (ii) Distal end is produced into a hook-like **acrocoracoid process**, while proximal end is flattened to articulate with **coracoid** groove on the antero-lateral border of sternum. (iii) Below acrocoracoid process, the inner surface of coracoid articulates with scapula, while outer surface contains a cup-shaped **glenoid cavity** for humerus head.

- (3) **Scapula.** (i) It is a sabre-like bone. (ii) Anteriorly it contains a cup-shaped depression, forming part of glenoid cavity and on inner side it has an **acromian process**.
- (4) **Clavicles.** (i) They fuse to form a V-shaped **furcula** or **merrythought** or **wishbone**. (ii) Each clavicle is a rod-shaped bone. (iii) Ventrally both clavicles unite to form interclavicle or **hypocleidium**.

#### 4. Pectoral Girdle of Rabbit

**Comments :**

- (1) Each half of pectoral girdle is made up of **clavicle** and **scapula-coracoid** (Fig. 24).
- (2) **Scapula-coracoid.** (i) It is a triangular replacing bone. (ii) The apex contains a concavity called **glenoid cavity** for humerus head. (iii) Over **glenoid cavity** hangs a **coracoid process**. (iv) A distinct vertical **spine** divides outer surface of scapula and it terminates below into an **acromian process**, which further gives posteriorly a **metacromian process**.

### PELVIC GIRDLES

#### 1. Pelvic Girdle of Frog

**Comments :**

- (1) Two pelvic girdles form a V-shaped structure. Each half of girdle or **innominatum** is composed of **ilium**, **ischium** and **pubis** which unite posteriorly into a vertical disc bearing a cup-shaped cavity, called **acetabulum**, on either side (Fig. 25).
- (2) **Ilium.** (i) It is a long bone meeting with transverse process of ninth vertebra. (ii) Dorsally it contains a distinct **iliac crest**. (iii) Two ilia meet posteriorly at an **iliac symphysis**.
- (3) **Pubis.** It is a reduced calcified cartilage forming major part of acetabulum. The pubic cartilages of both sides are completely fused.
- (4) **Ischium.** Two ischia give rise to one-third of disc and completely fuse together at an ischiatic symphysis.

#### 2. Pelvic Girdle of *Varanus* : Left Innominate : Lateral View

**Comments :**

- (1) (i) It is composed of usual three bones, namely **ilium**, **pubis** and **ischium**. (ii) Three bones are very hard and solid. (iii) Externally, at the junction of three bones is a large **acetabulum** for head of femur. (iv) Joints are distinct (Fig. 25).
- (2) **Ilium.** (i) It is a rod-shaped bone constituting major part of **acetabulum**. (ii) It articulates with sacral vertebrae. (iii) It has a **pre-acetabular process**.
- (3) **Pubis.** (i) It is a curved bone. (ii) Two pubes meet at a **pubic symphysis**, which contains a cartilage called **epipubis**. (iii) Pubis gives out a small rod-like process called **prepubis**. (iv) Pubis contributes to one-third of **acetabulum** and is perforated by a small foramen for **obturator nerve**.
- (4) **Ischium.** (i) Two ischia are flat and curved bones meeting at an **ischiatic symphysis**. (ii) From ischiatic symphysis, a rod-shaped hypoischium extends backwards to support ventral wall of cloaca.

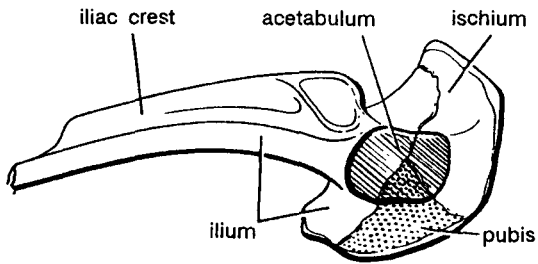

LEFT HALF OF PELVIC GIRDLE OF FROG  
(Lateral view)

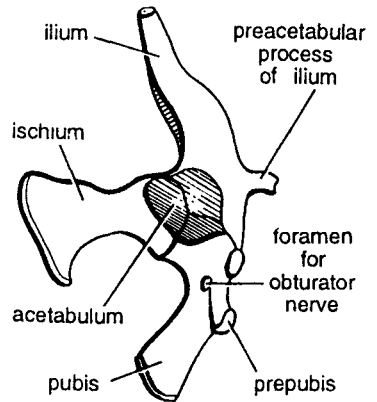

PELVIC GIRDLE OF VARANUS  
LEFT INNOMINATUM (Ventral view)

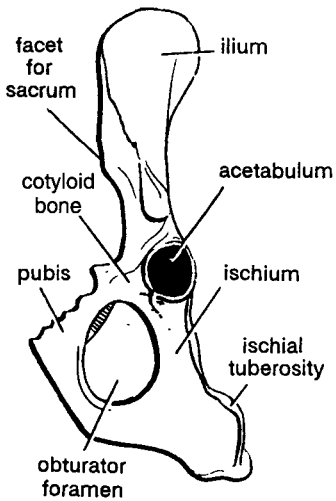

PELVIC GIRDLE OF RABBIT  
(Left half in lateral view)

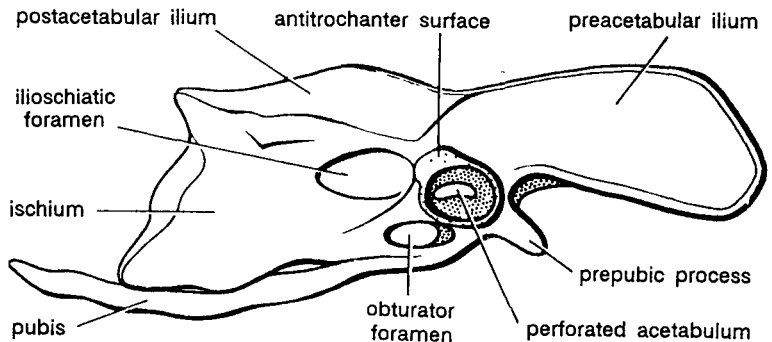

RIGHT INNOMINATUM OR PELVIC GIRDLE OF FOWL  
(Outer view)

Fig. 25. Pelvic girdle of Frog, *Varanus*, Rabbit and Fowl.

### 3. Pelvic Girdle of Fowl : Outer View

**Comments :**

- (1) Although pelvic girdle of fowl contains usual three parts, namely **ilium**, **ischium** and **pubis**, yet it is noteworthy because of (i) absence of ventral symphysis due to large eggs, (ii) firm union with vertebral column, and (iii) incomplete ossification of acetabulum.
- (2) **Ilium.** (i) Ilium is a long lamellar bone differentiated into **pre-acetabular** and **postacetabular parts**. (ii) Ilium forms dorsal part of the perforated acetabulum.
- (3) **Ischium.** (i) It extends behind **acetabulum**. (ii) It is fused with ilium posteriorly and separated anteriorly by an **ilio-ischiatic** foramen.
- (4) **Pubis.** (i) It is a slender bone forming ventral part of acetabulum. (ii) Behind acetabulum pubis is separated from ischium by an **obturator foramen**. (iii) Anteriorly it gives a small **prepubic process**.



## 4. Pelvic Girdle of Rabbit : Left Half : Lateral View

### Comments :

- (1) Two halves of pelvic girdles are united at a **pubic symphysis**. Each half or innominatum contains **ilium, ischium** and **pubis**. Three bones are fused together forming hip bone. External to hip bone is a cup-shaped **acetabulum** (Fig. 25).
- (2) **Ilium.** (i) It is a blade-like bone. (ii) It articulates with **sacrum**.
- (3) **Ischium.** (i) It forms postero-dorsal part of innominate bone. (ii) Posteriormost part is thickened forming an **ischial tuberosity**.
- (4) **Pubis.** (i) It is a small bone forming ventro-lateral part of girdle. (ii) A small **cotyloid bone** prevents pubis from reaching upto acetabulum. (iii) Pubis is separated from ischium by a large **obturator foramen**.

## FORELIMB BONES

### 1. Forelimb Bones of Frog

Humerus, radio-ulna and hand bones constitute bones of forelimb.

### Comments :

- (1) **Humerus.** (i) It is a short, cylindrical and slightly curved bone of upper arm. (ii) Proximal end fits into glenoid cavity of pectoral girdle. It is swollen forming **head**, which is covered by calcified cartilage. (iii) Below head is a **deltoid ridge** for muscle attachment. (iv) Distal end has a prominent **trochlea** or **capitulum** and a **condylar ridge** for articulation with radio-ulna.
- (2) **Radio-ulna.** (i) It is the compound bone of forearm formed by fusion of **radius** and **ulna**. (ii) Proximal end contains a concavity for articulation with **capitulum** of humerus and an **olecranon process**. (iii) A groove divides radius and ulna distally; each terminating into a facet to articulate with **carpal bones**.

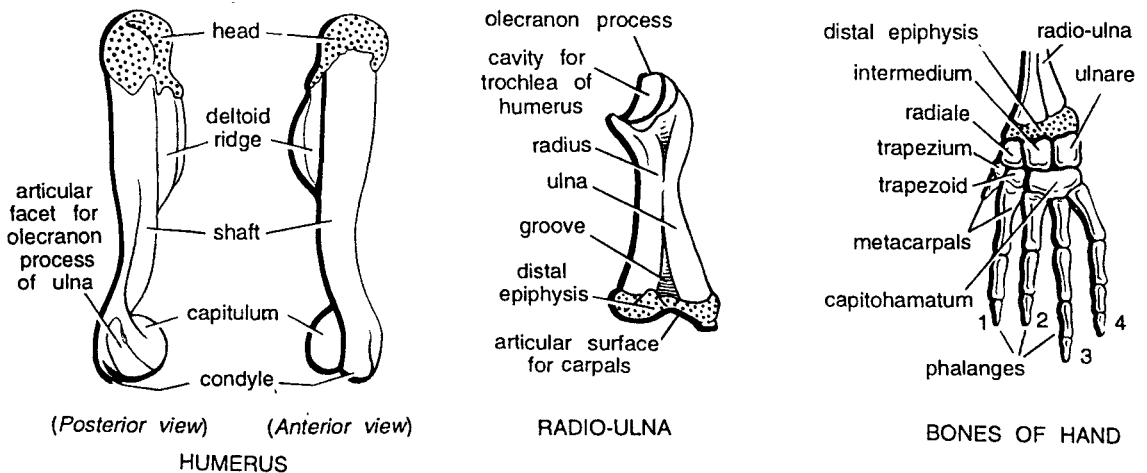

Fig. 26. Forelimb bones of Frog.

- (3) **Bones of hand.** (i) Wrist bones are called as **carpals**, which are 6 in number and arranged in two rows of 3 each. (ii) Bones of proximal row, namely **radiale**, **intermedium** and **ulnare**, articulate with radio-ulna. (iii) Bones of distal row, namely **trapezium**, **trapezoid** and **capitohamatum**, articulate with **metacarpals**. (iv) First metacarpal is rudimentary and without a digit and **phalanges**. Besides metacarpals, digits are internally supported by short bony rods, known as **phalanges**. First and second digits contain two phalanges each, while third and fourth digits have 3 phalanges each. (v) Claws are absent.

## 2. Forelimb Bone of *Varanus*

### Comments :

Forelimb is constituted by **humerus**, **radius** and **ulna** and bones of forefoot or **hand**.

- (1) **Humerus.** (i) It is upper arm, single bone, with both ends expanded. (ii) Proximal end contains **head** which fits into **glenoid cavity**. (iii) The head and a **medial process** enclose a **bicipital fossa**. (iv) **Deltoid ridge** present. (v) Distal end pulley-like and **trochlea** contains two articular facets for radius and ulna.
- (2) **Radius and ulna.** (i) Unlike frog, radius and ulna are not **fused**. (ii) **Radius** is slender and made up of a shaft and two epiphyses. Distal end contains a concave articular facet and a pre-axial styloid process; (iii) **Ulna** is stouter. Proximal end contains **olecranon process** and distal end has a convex articular surface for carpus.
- (3) **Bones of forefoot or hand.** (i) Wrist is made up of 10 small polyhedral rounded bony carpals arranged in two rows. (ii) Proximal row contains **three carpals**, namely **radiale**, **ulnare** and **intermedium**. (iii) Distal row has 5 carpals. (iv) A **centrale** is found between two rows and a **pisciform** is attached to the distal epiphyses of ulna. (v) **Manus** contains five elongated metacarpals and bears 5 digits made up of 2, 3, 4, 5 and 3 phalanges, respectively. (vi) Each terminal phalanx contains a horny claw.

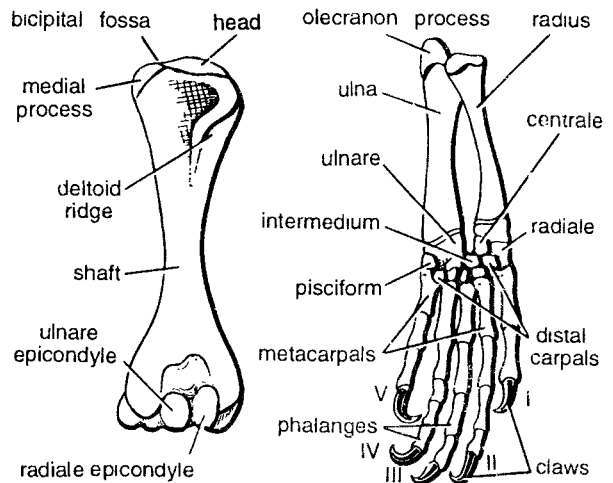

HUMERUS      RADIUS-ULNA & BONES OF HAND

Fig. 27. Forelimb bones of *Varanus*.

## 3. Forelimb Bones of Fowl

The forelimb is adapted for flight with the result radius and ulna do not move upon each other, distal carpals fuse with the metacarpals forming **carpometacarpus** and only three digits are present. Forelimb is composed of humerus, radius, ulna, carpals, **carpometacarpus** and phalanges.

### Comments :

- (1) **Humerus.** (i) It is **pneumatic** upper arm bone expanded at both ends. (ii) Proximal end contains a convex **head**, which bears one smaller pre-axial tuberosity or **deltoid ridge** for pectoral muscles and other greater post-axial tuberosity, which contains a large **pneumatic foramen** communicating with air space in shaft of bone. (iii) Distal end contains two trochlear articular surfaces for **radius** and **ulna**. **Anterior view** **deltoid ridge condyles** and intercondylar groove. **Posterior view** shows **pneumatic foramen** and **olecranon fossa**.

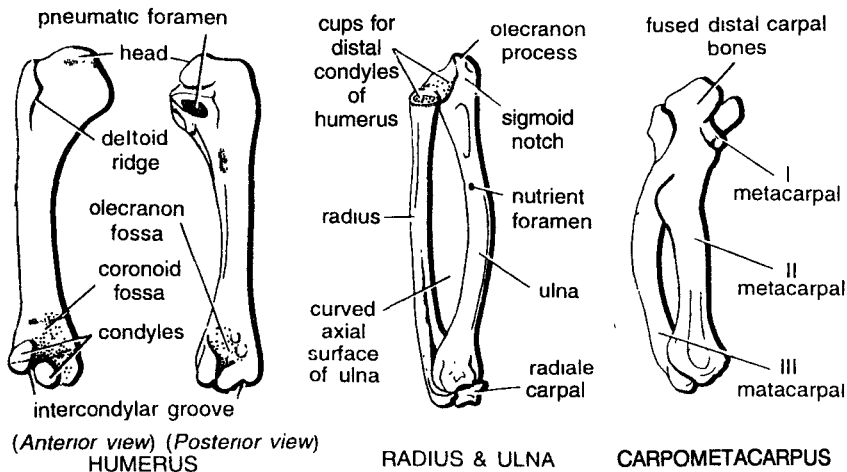

Fig. 28. Forelimb bones of Fowl.

- (2) **Radius-ulna.** (i) **Radius** and **ulna** constitute separate bones. (ii) Radius is straight and slender. Proximal end has a cavity for **outer condyle of humerus**, while distal knob-like end fits into **radiale carpal**. (iii) Ulna is longer and curved. Proximal end contains a facet for **inner condyle** of humerus and is produced as **olecranon** process. Distal end articulates with **carpals** and **radius**. Ulna also has sigmoid notch and nutrient foramen.
- (3) **Carpals.** **Radiale** articulating with radius and **ulnare** articulating with ulna form proximal carpals.
- (4) **Carpo-metacarpus.** (i) Three metacarpals fuse with distal row of carpals to form **carpometacarpus**. (ii) First metacarpal is stumpy, second in the form of a straight bone and third slightly curved outwardly.
- (5) **Phalanges.** Three digits only. Pox or first digit has a single phalanx, index or second digit has two phalanges, while third digit has only one phalanx.

#### 4. Forelimb Bones of Rabbit

Forelimb comprises of **humerus, radius, ulna** and **bones of forefoot or hand**.

**Comments :**

- (1) **Humerus.** (i) It is a rod-shaped bone. (ii) **Head** articulates with glenoid cavity. (iii) Close to head are outer greater and inner lesser **tuberosities** and **bicipital fossa**. (iv) Deltoid ridge present. (v) Distally humerus contains a pulley-like **trochlea** to articulate with ulna. (vi) Just above **trochlea** are **coronoid** and **olecranon** fossae.
- (2) **Humerus** in posterior view shows **bicipital fossa, lesser tuberosities, greater tuberosity, shaft, supratrochlear lumen head and trochlea**.
- (3) **Radius and ulna (Side view).** (i) **Radius** and **ulna** are separate but united firmly at both ends. (ii) Radius is smaller and curved. (iii) At the proximal end of ulna is an **olecranon process** which articulates with **olecranon fossa** of humerus. (iv) At the base of olecranon process is a **sigmoid notch** which fits into **trochlea** of humerus.
- (4) **Bones of forefoot or hand.** (i) Wrist contains nine small bones in two rows, namely **radiale, intermedium** and **ulnare** in proximal row and **single centrale, trapezium, trapeziod, magnum, and unciform** in distal row. (ii) A sesamoid bone or **pisciform** is found on ventral side of carpus. (iii) Manus has five digits with 2, 3, 3, 3 and 3 phalanges, respectively. (iv) Terminal phalanx bears a horny claw.

(Z-21)

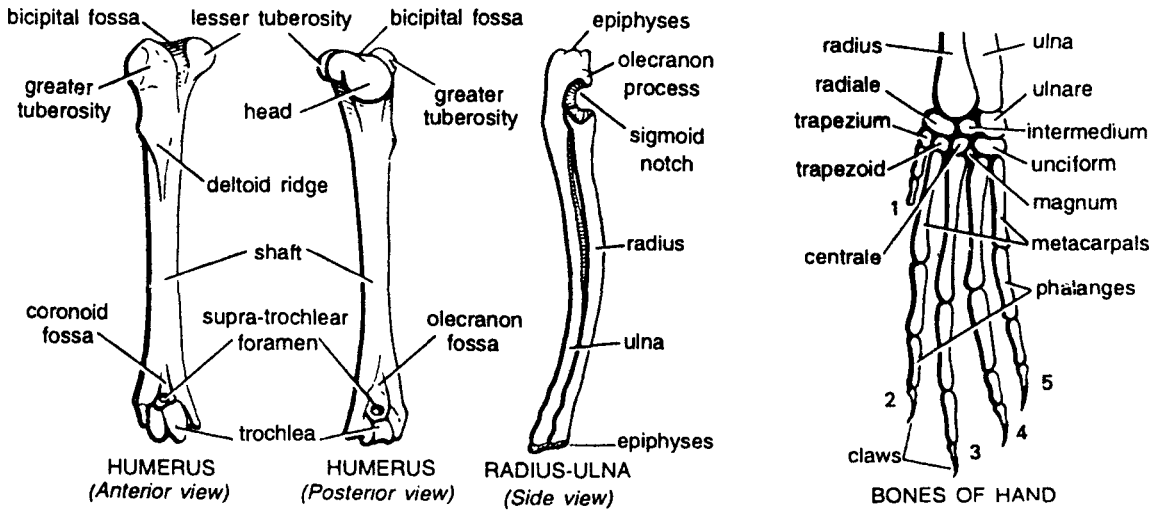

Fig. 29. Forelimb bones of Rabbit.

## HIND LIMB BONES

### 1. Hind Limb Bones of Frog

Hind limb constitute the femur, tibio-fibula, astragalus-calcaneum and bones of foot.

Comments :

- (1) **Femur.** (i) It is thigh bone having expanded ends, covered with calcified cartilages. (ii) Proximal end or **head** articulates with **acetabulum** while distal end with **tibio-fibula**.
- (2) **Tibio-fibula.** (i) These are shank bones and are elongated. (ii) Tibia is inner and fibula is outer, both fused together to form a compound bone. (iii) Proximally tibia contains a **tibial crest**. (iv) At proximal

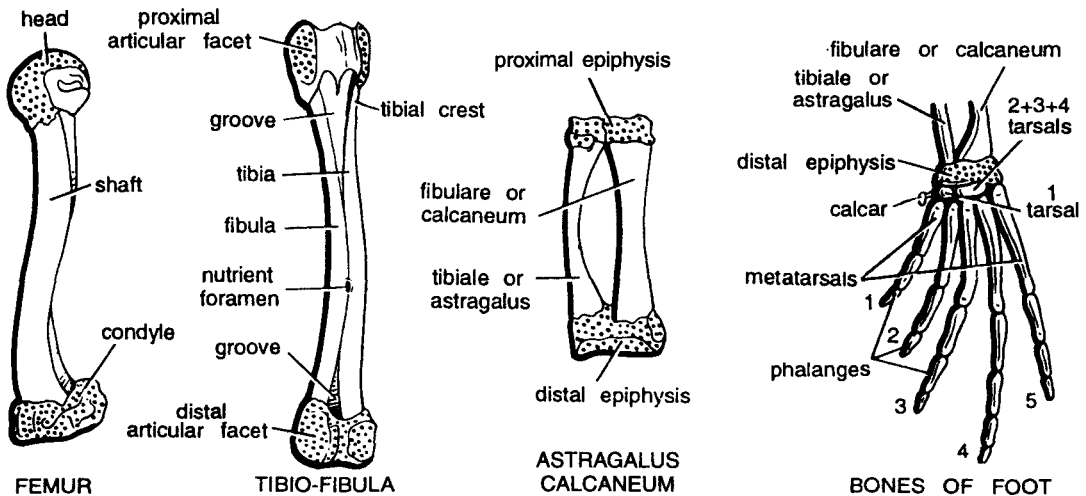

Fig. 30. Hind limb bones of Frog.

end tibio-fibula articulates with femur, and at distal end with astragalus-calcaneum. Structures seen are proximal articular facet, groove, tibia, fibula, nutrient foramen, distal groove and distal articular facet.

- (3) **Astragalus-calcaneum.** (i) These are proximal ankle bones united at both ends and covered by proximal and distal epiphyses of calcified cartilages at proximal and distal ends respectively. (ii) Outer thicker straight bone is calcaneum of fibulare, while inner thinner and slightly curved bone is astragalus or tibiale.
- (4) **Bones of foot.** (i) Foot contains 5 long, slender bones, known as metatarsals, having five true toes. (ii) First, second, third, fourth and fifth digits contain 2, 2, 3, 4 and 3 phalanges respectively. (iii) Sixth toe is very small having 2 or 3 bones and is called as pre-hallux or calcar.

## 2. Hind Limb Bones of *Varanus*

Hind limb consists of femur, tibia, fibula and bones of hind foot.

### Comments :

- (1) **Femur.** (i) It is thigh bone having two epiphyses. (ii) Proximal end contains head, which fits into acetabulum, while distal end is pulley-shaped, having two tuberosities or condyles for articulation with tibia and fibula. (iii) Femur has lesser trochanter and greater trochanter on pre-axial and post-axial sides, respectively.
- (2) **Tibia and fibula and bones of hind foot.** (i) These are shank bones, (ii) Tibia is stout, curved and on pre-axial side, while fibula is slender and on post-axial side.
- (3) **Bones of hind-foot.** (i) It is made up of 5 tarsal bones. (ii) First, second, third, fourth and fifth toes contain 2, 3, 4, 5 and 3 phalanges, respectively. (iii) Each toe bears a terminal horny claw.

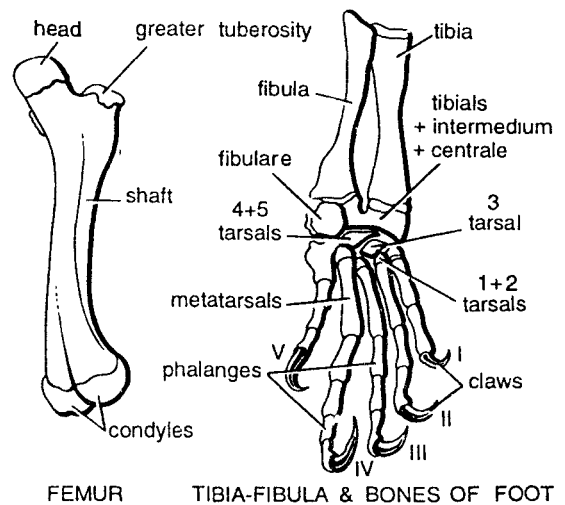

Fig. 31. Hind limb bones of *Varanus*.

## 3. Hind Limb Bones of Fowl

Hind limb comprises of femur, tibio-tarsus and fibula, tarsals, tarso-metatarsus and phalanges. Hind is modified for bipedal locomotion.

### Comments :

- (1) **Femur (Anterior view).** (i) It is cylindrical, short and curved thigh bone. (ii) Head fits into acetabulum and outwardly it contains greater trochanter. (iii) Distal end is pulley-shaped for patella bone and bounded by two condyles to articulate with tibia namely outer condyles and inner condyle with intercondylar fossa.

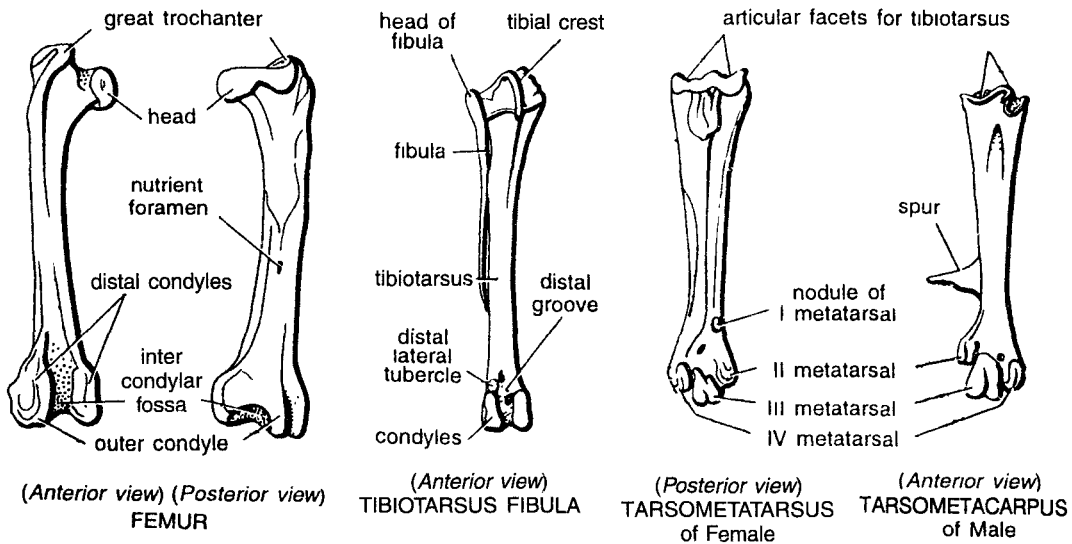

Fig. 32. Hind limb bones of Fowl.

- (2) **Femur (Posterior view)**. Contains **nutrient foramen**, **head**, **inter condylar fossa**, **outer condyle** and **inner condyle**.
- (3) **Tibio-tarsus and fibula (Anterior view)**. (i) **Tibio-tarsus** and **fibula** form shank bones. (ii) Tibio-tarsus is a straight and long bone formed by fusion of tibia with proximal row of tarsals (astragalus and calcaneum). (iii) Proximally, it articulates with femur and distally with tarso-metatarsus. (iv) **Fibula** is reduced to a small slender bone. Other structures are **tibial crest** **distal lateral tubercle**, **distal groove**.
- (4) **Tarso-metatarsus female (Posterior view)**. (i) It is a compound bone formed by fusion of distal row of tarsals with second, third and fourth metatarsals. Other structures seen at proximal end are **articular facets for tibiotarsus**, **nodule of I metatarsal**, **II metatarsal**, **III metatarsal** and **IV metatarsal**.
- (5) **Tarso-metatarsus. Male (Anterior view)**. In males tarsometatarsus contains a **spur**.
- (6) **Phalanges**. (i) Four toes. (ii) First or **hallux** is directed backwards and remaining three forwards. (iii) First, second, third and fourth toes have 2, 3, 4 and 5 phalanges respectively; each one is clawed.

#### 4. Hind Limb Bones of Rabbit

Hind limb is formed by **femur**, **tibio-fibula** and bones of **hindfoot**.

**Comments :**

- (1) **Right femur (Back view)**. (i) It is thigh bone. (ii) Proximal **head** articulates with acetabulum. (iii) **Lesser**, **greater** and **third trochanters** present for muscle attachment. (iv) Distally it has pulley-shaped structure, having two **lateral condyles** which enclose an intercondylar groove.
- (2) **Right femur (Front view)**. It shows **head**, **greater trochanter**, **lesser trochanter**, **shaft**, **patellar groove** and **condyles**.

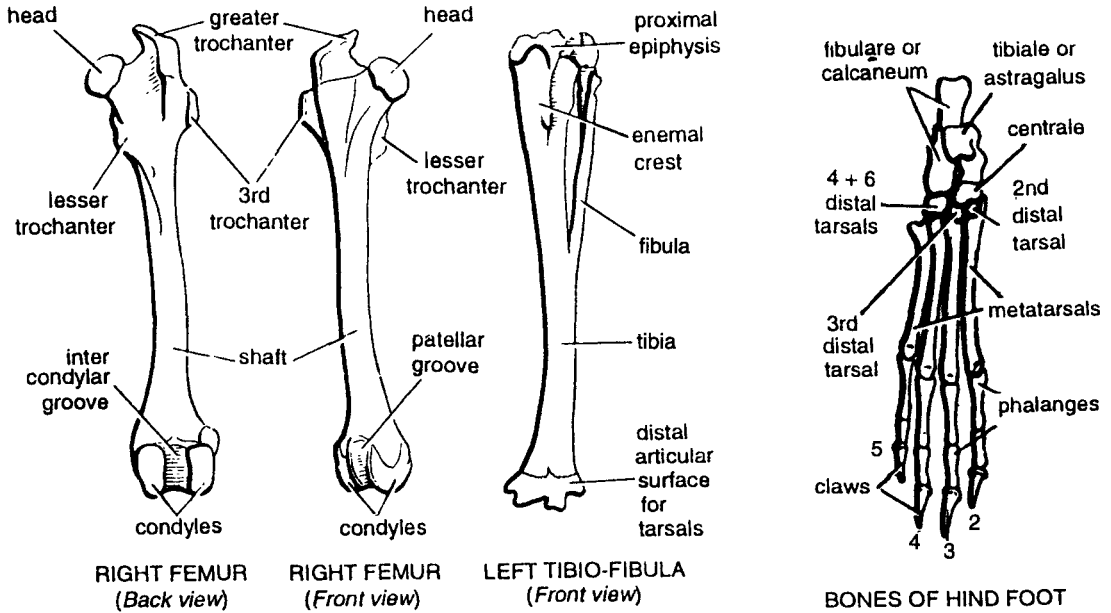

Fig. 33. Hind limb bones of Rabbit.

- (3) **Bones of hind foot.** (i) It contains **tarsal** bones in two rows. (ii) **Tibiale** and **intermedium** of the proximal row are fused to form **astragalus** on pre-axial side, while **fibulare** or **calcaneum** is the largest tarsal bone produced into a **spur** on post-axial side. (iii) Distal row contains three bones—**mesocuneiform**, **ectocuneiform** and **cuboid**. (iv) Only four toes each having three **phalanges**, the terminal one bearing a **claw**.

# Dissections : Major and Minor

# 11

## General Instructions for Dissection

While dissecting the animal keep in mind the following points :

- (1) **Listen** and **follow** carefully the instructions given by the teacher in your practical class.
- (2) Study well about the internal structures of the animal to be dissected.
- (3) Keep all the instruments in your dissecting box clean and sharp.
- (4) Always keep with you a A text book of practical zoology vertebrate and also hand-drawn diagram of the dissection.
- (5) Remember that **all vertebrates are dissected from ventral side**.
- (6) Wash the animal before dissection to remove excess of formalin or other fixing or killing chemical.
- (7) Keep a white sheet below the animal in dissecting dish.
- (8) Fix the animal in dissecting dish properly. Insert the pins obliquely.
- (9) While opening the animal never make deep incisions.
- (10) Remove the body wall layers in such a manner that all the internal organs are fully exposed.
- (11) Keep your dissection submerged in water.
- (12) Remove unwanted tissue by cutting with scissors.
- (13) **Blackpaper** your dissection. For example, keep small glazed black or blue paper below the nerves and nerve cord in dogfish.
- (14) Flag label only when asked by the teacher. While doing it cut small flags, write the name of the organ or tissue and pin it with needle. Keep the flag near the blunt end of the needle and pin near the organ or tissue by pointed end of the needle obliquely.
- (15) Always leave the dissection after cleaning the tissues in the dish.
- (16) **Display** nicely the dissection.



## SCOLIODON : DOGFISH

### 1. *Scoliodon* : External Features

**Procedure.** Take a formalin-preserved or freshly-killed *Scoliodon*, wash in tap-water and examine the external features. Draw lateral view of the specimen. Observe and note the following features :

- (1) **Size.** Females are larger than males. Size in both specimens varies from 30 to 60 cm.
- (2) **Shape.** Spindle-shaped. Head is dorso-ventrally flattened, while rest of the body is laterally compressed.
- (3) **Colouration.** The back and sides of body are brownish in colour, while under-surface is yellowish white.
- (4) **Texture.** The body surface is rough to touch due to backwardly-directed spines of the placoid scales.
- (5) **Divisions.** The entire body is regionated into **head, trunk** and **tail**.
  - (a) **Head.** It is flattened and produced into **snout** in front of mouth. Note the following structures in head :
    - (i) **Mouth.** It is crescentic in shape, found on the ventral surface and is guarded by the upper and lower jaws which contain backwardly-directed conical teeth.
    - (ii) **Nostrils.** These are obliquely-placed small apertures on either side of body, anterior to the mouth.
    - (iii) **A pair of eyes.** Each eye is large and situated on the lateral side of head. It contains upper eyelid, lower eyelid and a thin transparent **nictitating membrane**.
    - (iv) **Pores.** Several **ampullary** pores are present on the upper and lower surfaces of the head. Each pore opens into the lateral line canal.
    - (v) **Gill-slits.** There are five gill slits on either side, a little behind the head.
  - (b) **Trunk.** This region constitutes major part of the body starting from behind the gill-slits up to cloacal aperture. Trunk contains **median unpaired fins** and **paired lateral fins**.
  - (c) **Median fins** include :
    - (i) **First dorsal fin.** It is found anterior to middle part of the body.
    - (ii) **Second dorsal fin.** It is found a little behind the first dorsal fin and is a bit smaller than the first.
    - (iii) **Ventral fin.** It is found on ventral side, little distance to the position of second dorsal fin.
  - (d) **Paired fins** are :
    - (i) A pair of pectoral fins. These are large fins found just behind the gill-slits and in horizontal plane.
    - (ii) A pair of pelvic fins. These are very small and found on either side of cloacal aperture.
  - (e) **Tail.** The portion of the body behind the cloaca is called **tail**. It propels the fish through the water by **caudal fin**. The caudal fin contains **epicaudal** and **hypocaudal lobes**. At the junction of caudal fin and tail is a caudal pit.

A pair of **claspers** are found attached to the pelvic fins in males only. Sides of the fish contain faintly-marked **lateral lines**.

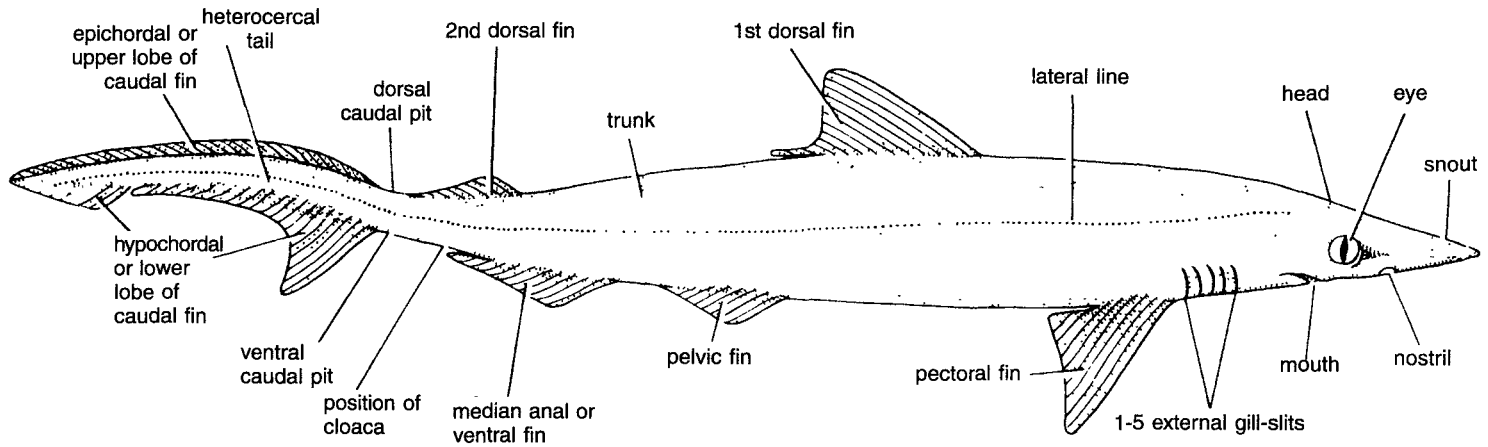

Fig. 1. Dogfish (*Scoliodon*) : External features.

## 2. *Scoliodon* : General Anatomy

**Procedure.** Take a preserved specimen, wash in water and lay down on the dissecting board with the ventral surface upwards or facing towards you and fix the animal by pinning the pectoral fin. Make a mid-longitudinal incision in body wall from the cloacal aperture up to the pectoral girdle and also cut transversally at each end of the longitudinal incision. Reflect and pin down the cut flaps. Examine the following organs :

- (1) **Pharynx and oesophagus.** Behind the pharynx is a short oesophagus which leads into the stomach.
- (2) **Stomach.** It is J-shaped and divided into the proximal **cardiac stomach** and distal **pyloric stomach** joined by a **blind sac**.
- (3) **Intestine.** Pyloric stomach opens into the wide intestine, which is internally folded into the **scroll valve**, which can be seen by cutting transversally or longitudinally.
- (4) **Rectum.** The intestine leads into cloaca. A large **rectal** or **caecal gland** opens on the dorsal surface of rectum.
- (5) **Liver.** It consists of two large and elongated lobes ventral to cardiac stomach. The two lobes are anteriorly jointed. **Gall bladder** is found on the dorsal lobe.
- (6) **Pancreas.** It is a bilobed compact gland, situated in the angle between two limbs of stomach.
- (7) **Spleen.** It is found in the coils of the pyloric stomach.
- (8) **Vascular organs.** Structures seen are the **pericardium**, **heart (auricle and ventricle)**, **conus arteriosus**, **ventral aorta** and **septum transversum** and hepatic portal vein.
- (9) **Male urinogenital organs.** These include **testes**, **vasa deferentia**, **vesiculae seminales**, **sperm sacs**, **caecal gland**, **kidneys**, **ureters** and **cloaca**.
- (10) **Female urinogenital organs.** The female specimen has **ovaries**, **oviducts** with **oviducal funnels**, **epigonal organs**, **shell glands**, **uterus**, **caecal gland**, **kidneys**, **ureters** and **cloaca**.

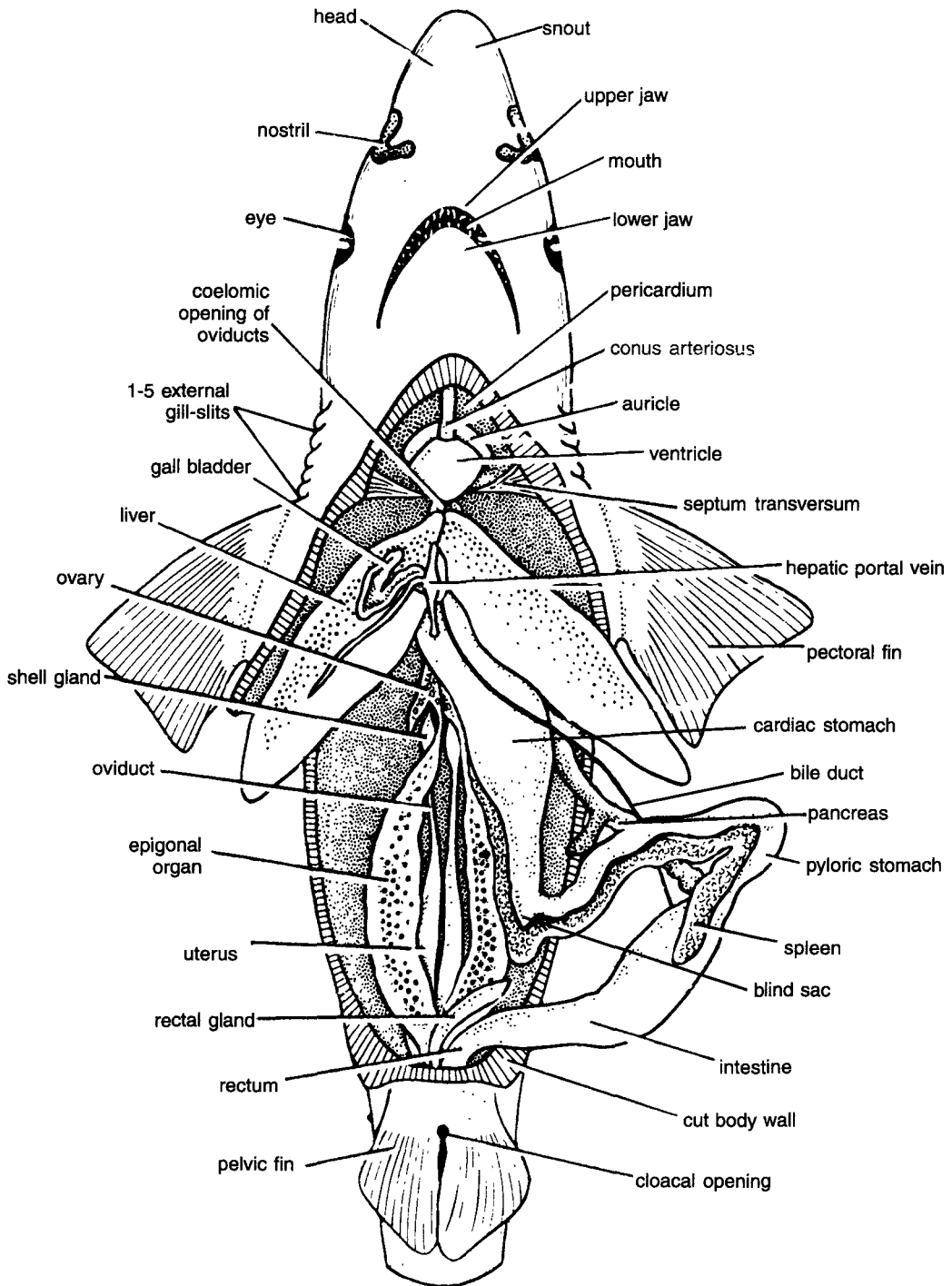

Fig. 2. Dogfish (*Scoliodon*) : General anatomy of female.

### 3. *Scoliodon* : Heart and Afferent Branchial Arteries

**Procedure.** For exposing heart and afferent branchial arteries, cut through the pectoral girdle and remove its middle portion. Take care not to injure the heart below. Remove the pericardium.

- (1) **Heart.** It is a dorso-ventrally bent muscular tube containing four chambers, namely **sinus venosus**, **auricle**, **ventricle** and **conus arteriosus**.
- (2) **Afferent branchial arteries.** The **conus arteriosus** is continued forward as **ventral aorta** which gives rise to **afferent branchial arteries**.

The **ventral aorta** runs up to the posterior border of the pharynx. Distally it divides into two **innominate arteries**. Each innominate artery again divides into **I afferent branchial artery** and **II afferent branchial artery**. **III, IV and V afferent branchial arteries** originate directly from the **ventral aorta** at equal distances from each other. Five pairs of afferent branchial arteries supply to five pairs of gills.

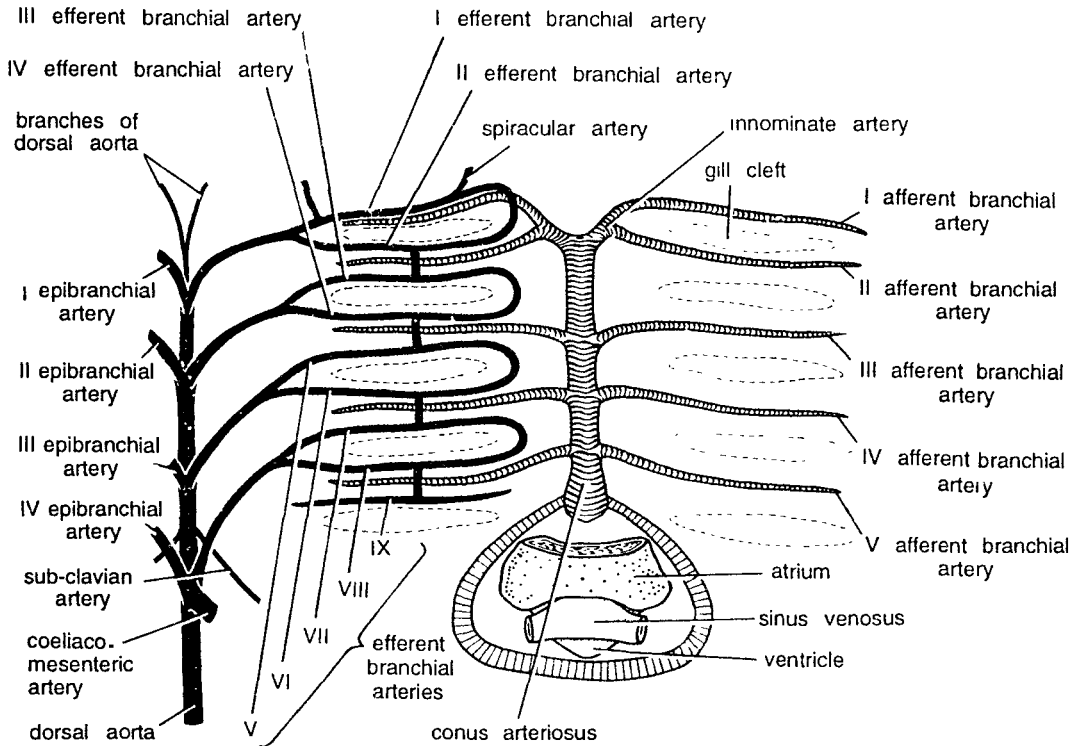

Fig. 3. Dogfish (*Scoliodon*) : Afferent and Efferent branchial arteries.

### 4. *Scoliodon* : Efferent Branchial Arteries

**Procedure.** For efferent branchial arteries dissect the fish from the roof of the pharynx.

There are 9 efferent branchial arteries on each side. The **I+II, III+IV, V+VI and VII+VIII efferent branchial artery** form four pairs of **loops**. The **ninth efferent branchial artery** joins with the **VIII** branchial artery. The four loops are connected together by longitudinal vessels. Each loop is continued as an **epibranchial artery**. Such as **I epibranchial artery, II-epibranchial artery, III epibranchial artery and IV-epibranchial artery**. These four pairs of epibranchial arteries unite to form **dorsal aorta**.

Also examine some main arteries supplying the head such as the **afferent spiracular artery**. Subclavian artery, coeliacomesenteric artery and branches of dorsal aorta.

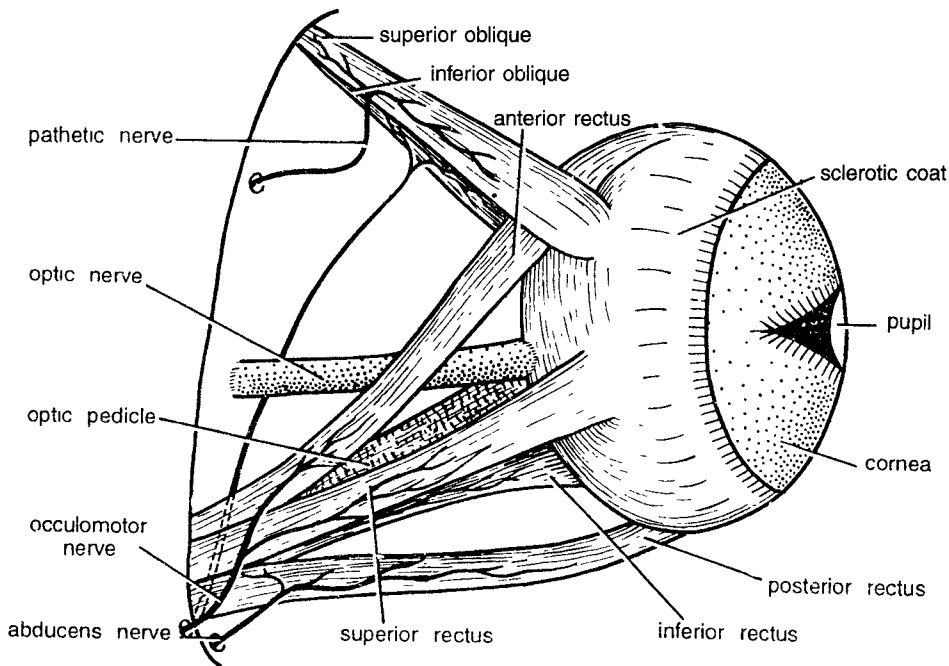

Fig. 4. Dogfish (*Scoliodon*) : Dissection of eye muscles.

### 5. *Scoliodon* : Eye Muscles

**Procedure.** Remove the eyelids and nictitating membrane to expose the eye-ball and its muscles. The eye muscles are inserted into the eye-ball in two groups. Note the following six eye muscles :

- (1) **Superior rectus.** Inserted on the dorsal surface of the eye-ball.
- (2) **Inferior rectus.** Inserted on the ventral surface of the eye-ball.
- (3) **Anterior rectus.** Inserted on the anterior surface of the eye-ball.
- (4) **Posterior rectus.** Inserted on the posterior surface of the eye-ball.
- (5) **Superior oblique.** Inserted on the dorsal surface of the eye-ball.
- (6) **Inferior oblique.** Inserted on the ventral surface of eye-ball.

**Optic peduncle.** It is a cartilaginous stalk holding eye in the orbit.

### 6. *Scoliodon* : Internal Ear

**Procedure.** The internal ear of membranous labyrinth lies in the auditor capsule just behind the orbit on either side. The auditory capsules are seen as bulgings on either side. Remove the skin over auditory capsules. Careful observation shows ridges of anterior vertical, horizontal and posterior vertical semicircular canals. The cartilage capsule can be gently broken by forceps. Take care not to injure the canals of membranous labyrinth. Locate the vertical canals and proceed.

The internal ear consists of **anterior vertical canal, posterior vertical canal, horizontal canal, ampullae of anterior vertical canal, horizontal canal and posterior vertical canal, lagena cochlea, recessus utriculi, utriculus and nerve supplies.**

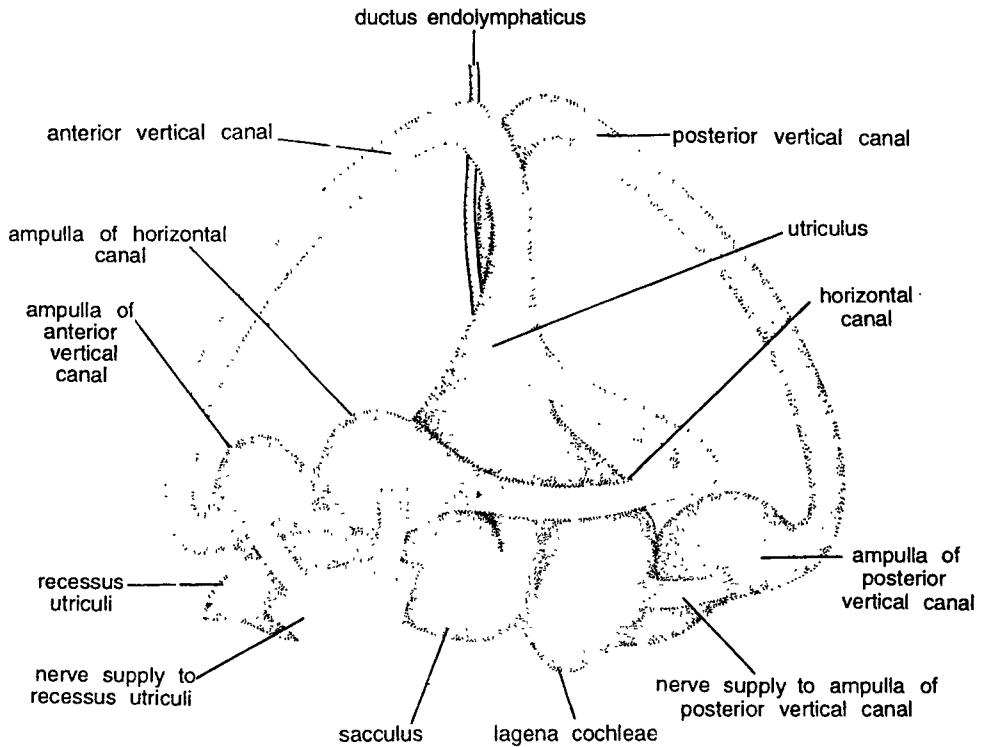

Fig. 5. Dogfish (*Scoliodon*) : Internal ear.

## 7. *Scoliodon* : Cranial Nerves

**Procedure.** Make a longitudinal incision in the middle of head from the gill cleft region up to the snout and also make transverse incisions on one side up to the lower edges. Remove the flap of skin. There are 10 pairs of cranial nerves emerging from the cranium as given in the following table :

**Table 2. Cranial Nerves of *Scoliodon*.**

Name of the Nerve	Originates from	Nature	Innervation
<b>I. Olfactory</b>	Olfactory lobe	Sensory	Nose epithelium
<b>II. Optic</b>	Optic thalamus	Sensory	Retina
<b>III. Oculomotor</b>	Ventral surface of mid-brain	Motor	Eye muscles (anterior rectus, superior and inferior rectii and inferior oblique)
<b>IV. Pathetic</b>	Dorso-lateral side of mid-brain	Motor	Superior oblique muscle of eye
<b>V. Trigeminal</b>	Side of medulla just below corpora restiformis	Mixed	
It has 5 branches :			
(a) <i>Ophthalmicus profundus</i>	—	—	Olfactory capsule and dorsal skin of snout
(b) <i>Ophthalmicus superficialis</i>	—	—	Skin of snout

(Contd....)

Name of the Nerve	Originates from	Nature	Innervation
(c) <i>Maxillaris superior</i>	—	—	Skin of upper jaw
(d) <i>Maxillaris inferior</i>	—	—	Posterior part of upper lip
(e) <i>Mandibularis</i>	—	—	Muscles of lower jaw
<b>VI. Abducens</b>	Ventral side of medulla	Motor	Posterior and external rectus muscles of eyes
<b>VII. Facial</b>			
It has the following branches :	Cranium		
(a) <i>Ophthalmicus superficialis</i>	—	—	Sense organs of snout
(b) <i>Ramus buccalis</i>	—	—	Infra-orbital lateral line organ
(c) <i>Ramus hyomandibularis</i>	—	—	
It has 3 branches :			
(i) <i>Mandibularis externus</i>	—	—	Mandibular canal
(ii) <i>Mandibularis internus</i>	—	—	Mucous membrane of buccal floor
(iii) <i>Hyoidean</i>	—	—	Muscles of hyoid arch
(d) <i>Ramus palatinus</i>	—	—	Roof of pharyngeal and buccal cavity
<b>VIII. Auditory</b>	Side of Medulla close to V and VIII cranial nerves	Sensory	Internal ear
<b>IX. Glossopharyngeal</b>	Ventro-lateral side of medulla		
It has 2 branches :			
(a) <i>Pre-trematic</i>	—	—	Mucous membrane 1st gill-slit & pharynx
(b) <i>Post-trematic</i>	—	—	Muscles of pharynx
<b>X. Vagus</b>	Side of medulla		
It has 3 branches :			
(a) <i>Branchialis</i>	—	—	Gills
(b) <i>Visceralis</i>	—	—	Visceral organs
(c) <i>Lateralis</i>	—	—	Lateral line of trunk

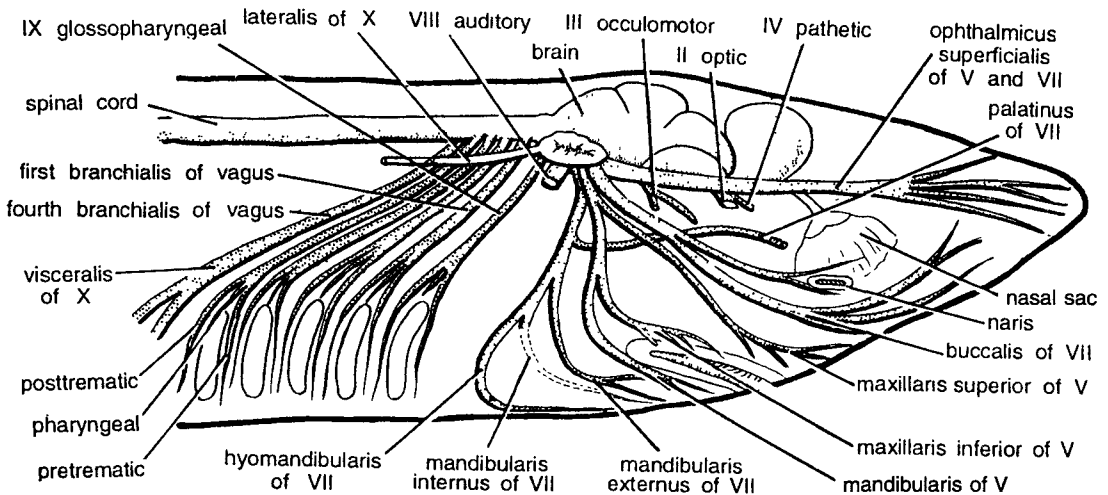

Fig. 6. Dogfish (*Scoliodon*) : Cranial nerves dissected in lateral view.



## HOPLOBATRACHUS TIGRINUS : FROG OLD NAME : RANA TIGRINA

### 1. Frog : External Features

**Procedure.** Note and examine the following in the living frog :

- (1) General body colour (adaptive colouration).
- (2) Absence of neck and tail (helps in swimming).
- (3) Hind limbs longer than forelimbs, which help in leaping and hopping.
- (4) Up and down movements of the floor of the buccal cavity, showing respiratory movements.
- (5) Distinguish between male and female frogs by copulatory pads in the hand of male.

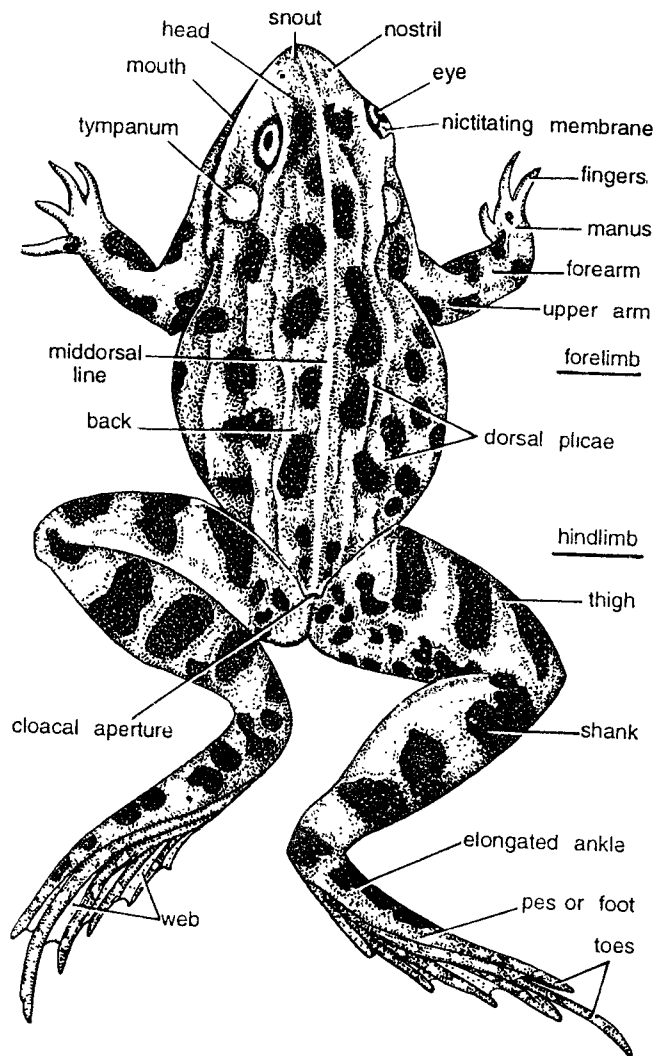

**Fig. 7.** Frog (*Hoplobatrachus tigrinus* = Old name *Rana tigrina*) : External features in dorsal view.

For detailed external morphology, take a frog freshly killed with chloroform vapour. Draw a lateral or dorsal view of the frog. Examine and note the following :

- (1) **Size.** *Hoplobatrachus tigrinus* (*Rana tigrina*) measures 12 to 20 cm in length.
- (2) **Shape.** Roughly it is on triangular plane and adapted for swimming.
- (3) **Texture.** Skin is smooth, moist and slippery.
- (4) **Colouration.** The dorsal skin is green or olive coloured with dark patches, while ventral is whitish.
- (5) **Division.** Body is divided into two regions — **head** and **trunk**.
  - (a) **Head.** Note the following structures in head which is conical and having blunt snout :
    - (i) **External nares.** These are two small openings lying near the anterior tip of snout.
    - (ii) **Eyes.** They are the most distinct parts of the head. Each eye is large, bright, protuberant, having golden **iris** and black rounded **pupil**. Each eye has an upper large and stationary **eyelid** and a lower small mobile **eyelid**.
    - (iii) **Nictitating membrane.** The upper part of lower eyelid forms a transparent **nictitating membrane**.
    - (iv) **Tympanum or tympanic membrane.** It is in the form of a circular area found posterior to each eye. It forms external boundary of the middle ear. The external ear is absent in frog.
    - (v) **Vocal sacs.** Found in males only under the head.
  - (b) **Trunk.** It forms major portion of the body. Note the characteristic raised hump. Trunk contains anterior forelimbs and posterior hind limbs.
    - (i) **Forelimbs.** Each comprises of **upper arm**, **forearm** and **hand** containing **wrist**, **palm** and **four digits** provided with **copulatory** and **articular pads**.
    - (ii) **Hind limbs.** These are folded at rest and each comprises of **thigh**, **shank** and **foot**. Foot is made up of **ankle**, **sole** and five digits.

## 2. Frog : Bucco-pharyngeal Cavity

**Procedure.** Open the mouth of the frog as much as you can and note the various structures in the buccopharyngeal cavity.

- (1) **Mouth** leads into **buccal cavity**, which is not sharply divided from **pharyngeal cavity** behind and hence they form common **bucco-pharyngeal** cavity formed by upper and lower jaws.
- (2) **Maxillary teeth** are found in single row in the upper jaw.
- (3) **Vomerine teeth** are found on the roof of upper jaw as two patch-like structures.
- (4) **Internal nares** are found anteriorly in the mouth cavity as two small openings.
- (5) **Eye-balls** bulge in from the roof of the upper jaw as two hemispherical structures.
- (6) **Openings of eustachian tubes** are in the form of two circular openings found at the rear of buccal cavity.
- (7) **Tongue** is long and bifid, attached anteriorly and free posteriorly.
- (8) **Gullet** is found between two jaws and another opening called **glottis** which is found below the gullet.
- (9) **Vocal sacs** are found in males having two lateral openings into the mouth cavity.

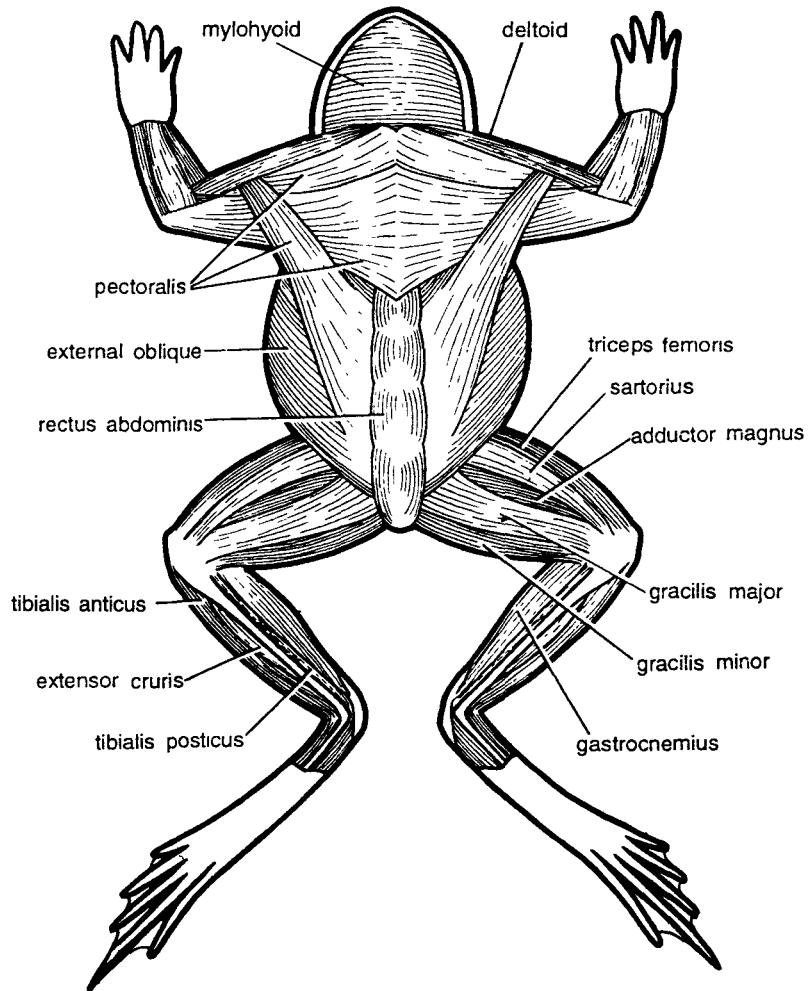

Fig. 8. Frog (*Hoplobatrachus tigrinus* = Old name *Rana tigrina*) : Dissection of muscles.

### 3. Frog : Muscular System

**Procedure.** Remove the skin of the dorsal surface and note the following muscles :

**Muscles on left side.** Deltoid, triceps femoris, sartorius, adductor magnus, gracialis major, gracialis minor and gastronemius.

**Muscles on right side.** Mylohyoid, pectoralis, external oblique, rectus abdominis, tibialis anticus, extensor cruris and tibialis posticus.

## 4. Frog : General Anatomy

**Procedure.** Kill the frog with chloroform vapours and lay it on its back in dissecting dish. Wash the frog, pin the limbs and press the pins with the base of forceps. Add water in the dish so that frog is completely submerged. Lift the abdominal skin with the forceps and make a mid-longitudinal incision from cloacal region up to the xiphoid cartilage and the pectoral girdle. Cut the skin of thighs to

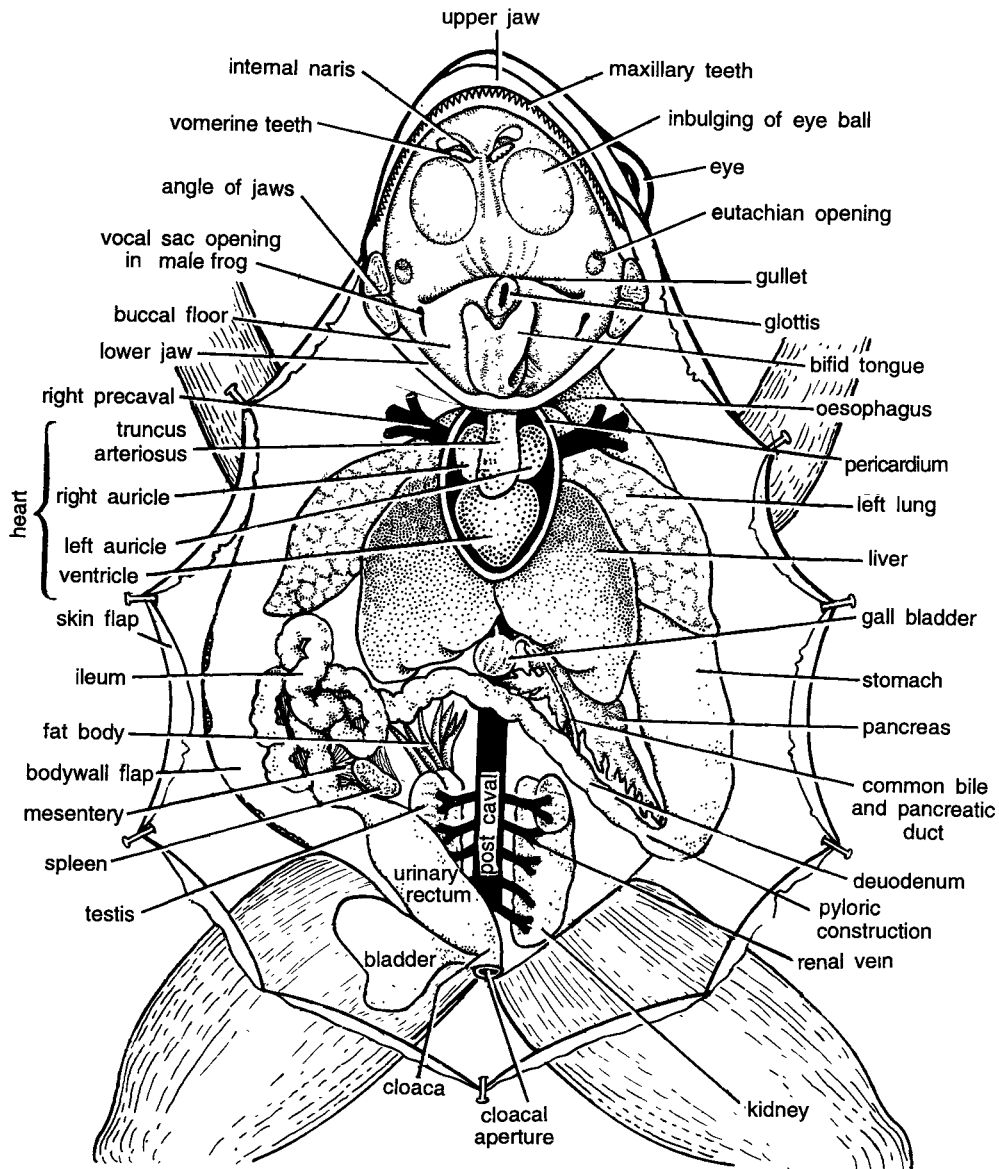

**Fig. 9.** Frog (*Hoplobatrachus tigrinus* = Old name *Rana tigrina*) : Dissection of buccal cavity and general anatomy (male frog).

*expose the muscles. Students generally cut or puncture the anterior abdominal vein, for which make two incisions on the sides of the abdominal skin. Ligate the anterior abdominal vein near the thighs and at its entrance into the liver and then cut between two ties. Examine and draw general viscera. Note that all the organs are connected by thin membranes called mesenteries. Study musculature, lungs, heart, liver, gall bladder, stomach, intestine, spleen, kidneys, fat-bodies, testes in male, ovaries and oviducts in female and urinary bladder.*

**Digestive system.** The inlet and outlet of the alimentary canal are mouth and cloaca. The **mouth** opening leads into the **bucco-pharyngeal** cavity which is followed by a short cylindrical **oesophagus**. The oesophagus opens into the **stomach**, which is muscular and curved lying on the left side of the abdominal cavity. It has **cardiac** and **pyloric** ends. The stomach opens into the intestine which comprises of **small intestine** and **large intestine**. The small intestine is called **ileum** and is thrown into several loops bound by mesenteries. The large intestine is short and straight and consists of the **rectum** which extends backwards and opens into the **cloaca**. The **urinary bladder** also opens into the cloaca. The accessory glands consist of **liver** having two unequal lobes. The two lobes are connected together by a median lobe or **isthmus**. The **gall bladder** lies between the two lobes. The **hepatic ducts** from the liver and **cystic ducts** from the gall bladder unite to form the **common bile duct**, which pierces the pancreas and accompanies the **pancreatic duct**, to open with it into the duodenum by a short common **hepato-pancreatic** duct near the pyloric end of the stomach.

## 5. Frog : Circulatory System

Circulatory system of frog comprises of three units (i) a pumping organ or **heart**, (ii) the distributing vessels or **arteries**, and (iii) the collecting vessels or **veins**.

### [I] Heart of frog

**Procedure.** *Remove pericardium to study the heart.* The heart is S-shaped, triangular, conical and highly muscularised organ with broad anterior and narrow posterior regions. It is three-chambered, containing two **auricles** above and a conical **ventricle** below. The dorsal side of the heart is characterized by pulmonary veins, post-caval vessel and a reduced thin-walled **sinus venosus**. The ventral side contains a tubular **truncus arteriosus**.

### [II] Venous system of frog

**Procedure.** *Take preferably a freshly-chloroformed or killed frog, Pin it in the dissecting dish and open it with ventral surface upwards. The veins, in the dissecting or operating position, lie above arteries. Don't pull unduly skin covering the thorax to the outside so as not to damage the musculo-cutaneous veins. Separate the anterior abdominal vein, tie it at both the ends and cut it in between. Separate alimentary canal from neighbouring organs by cutting mesenteries.*

**For renal portal system.** *Dissect the frog in the usual way. Separate the anterior abdominal vein and keep it intact. It is formed by the union of two pelvic veins lying in the anterior part of the pelvis. Try to separate the two pelvic veins from the thigh muscles by gently pulling the anterior abdominal vein forwards. Remove the vastus internus muscle lying on the outer side of the thigh to expose femoral vein. By scalpel cut through the pubic symphysis between the two thighs in order to expose the cloaca and two sciatic veins.*

De-oxygenated blood from all parts of the body is collected by the following :

- (1) **Pulmonary veins.** These collect oxygenated blood from lungs and open into left auricle.
- (2) **Caval veins.** The blood from rest of the viscera is poured by **caval veins** into the sinus venosus which, in turn, opens into the right auricle by a sinu-auricular aperture. The 3 caval veins are :

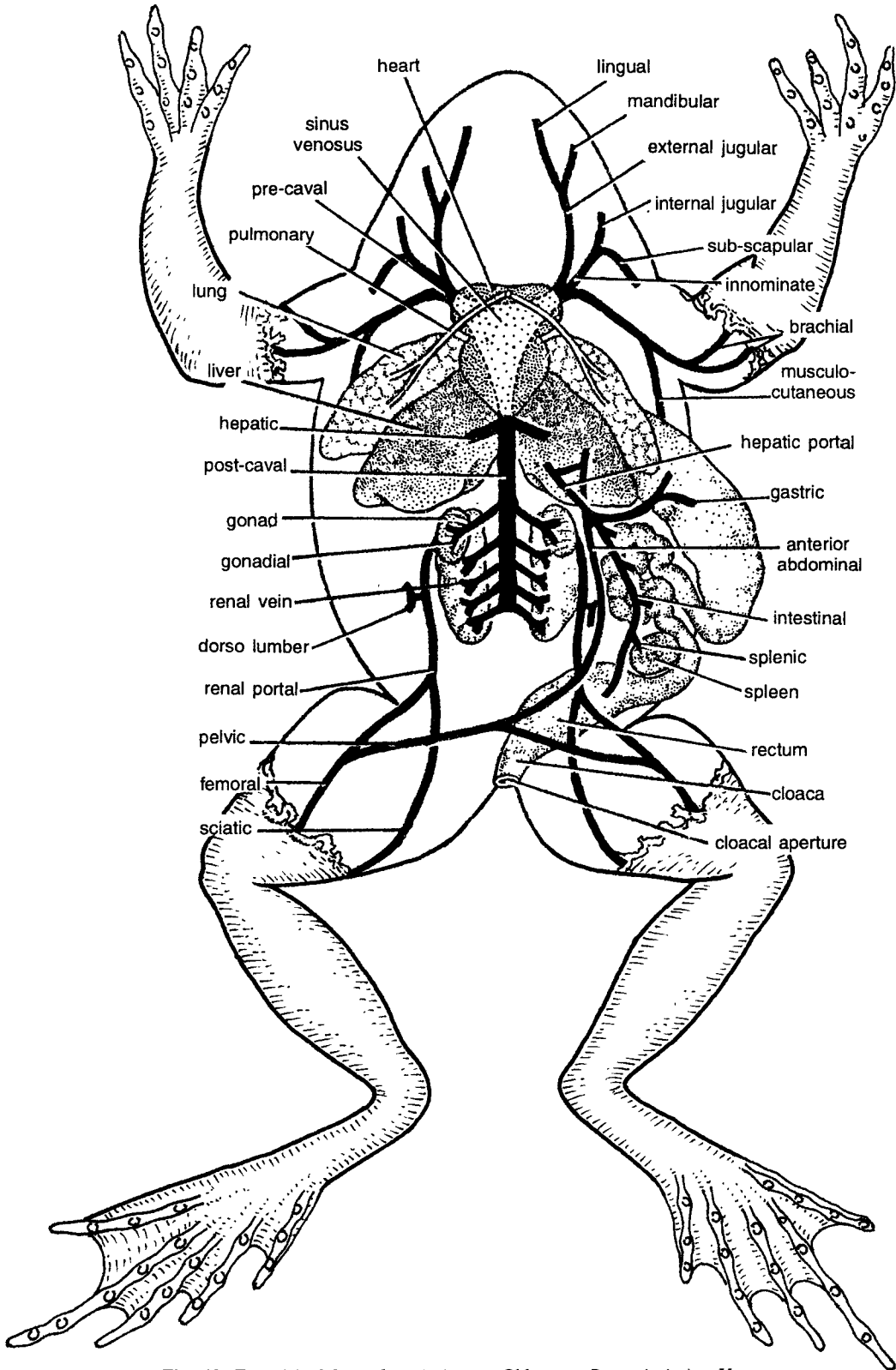

Fig. 10. Frog (*Hoplobatrachus tigrinus* = Old name *Rana tigrina*) : Venous system.

- (a) **Pre-cavals.** Two pre-cavals collect blood from anterior part of the body. Each pre-caval comprises of the following branches :
- (i) **External jugular.** It divides into two veins. The **lingual vein** collects blood from tongue and floor of the mouth. The **mandibular vein** collects blood from lower jaw.
  - (ii) **Innominate.** It also divides into two veins. The **internal jugular** collects blood from brain and orbit, while **sub-scapular** collects blood from shoulder and back arm.
  - (iii) **Sub-clavian.** It has two branches. The **branchial** collects blood from the arm. The **musculo-cutaneous** collects blood from muscles of abdomen and mucous membrane.
- (b) **Post-caval vein.** It receives blood from legs, kidneys, gonads and liver. It comprises of the following vessels :
- (i) **Femoral vein.** It collects blood from outer side of the leg.
  - (ii) **Sciatic vein.** It collects blood from inner side of the leg.
  - (iii) **Renal portal system.** **Femoral vein** divides into a **renal portal vein** and a **pelvic vein**. The sciatic vein joins with the renal portal vein, which runs on the outer side of kidney and enters kidney to break into several capillaries. The capillaries on emergence from kidney form 4 or 5 **renal veins**. The renal veins of two sides unite with post-caval vein. The double system of blood filtration, one in leg and another in kidneys, is called **renal portal system**. The renal portal vein also receives the **dorso-lumbar vein**, which collects blood from the back muscles.  
The two pelvic veins unite to form an **anterior abdominal vein**, which opens into the left lobe of the liver.
  - (iv) **Gonadial veins.** Each vein collects blood from a gonad and receives a small branch from the kidney. The gonadial veins join with the post-caval vein.
  - (v) **Hepatic veins.** A pair of these, from the liver, joins with the post-caval vein.
  - (vi) **Hepatic portal system.** This system comprises of veins which collect blood from the alimentary canal and communicate with the large **hepatic portal vein**. A **gastric vein** collects blood from stomach, an **intestinal vein** from intestine, a **duodenal vein** from duodenum, a **pancreatic vein** from pancreas, and a **splenic vein** from spleen.

### [III] Arterial system of frog

The arteries distribute the oxygenated blood to various parts of the body.

**Procedure.** *Dissect the freshly-killed frog as usual. Separate and tie both the ends of the anterior abdominal vein. Shift the alimentary canal to left hand side and pin it on the dissecting dish. Keep all the mesenteries intact. Tie the anterior vena cava. Lift the heart vertically, the anterior vena cava is seen on the dorsal side of the heart crossing over the three aortic arches of the same side. Insert a fine thread on the anterior vena cava and after encircling it tie with the thread. Cut this vein a little ahead of the tied portion. Cut the pubic symphysis between the two thighs in order to expose the iliac arteries. Follow the branches of the truncus arteriosus.*

**Truncus arteriosus** divides into branches and each branch on each side gives rise to three main vessels :

- (1) **Pulmo-cutaneous arch.** It divides into two arteries :
  - (a) **Pulmonary artery.** It supplies to lung in which de-oxygenated blood is carried.
  - (b) **Cutaneous artery.** It supplies to skin and buccal cavity.
- (2) **Carotid arch.** It divides into two arteries :
  - (a) **External carotid.** It supplies to tongue and hyoid.
  - (b) **Internal carotid.** It has a swollen **carotid labyrinth** and supplies to orbit and brain.
- (3) **Systemic arch.** The two systemic arches encircle around the heart and join together to form the **dorsal aorta**.

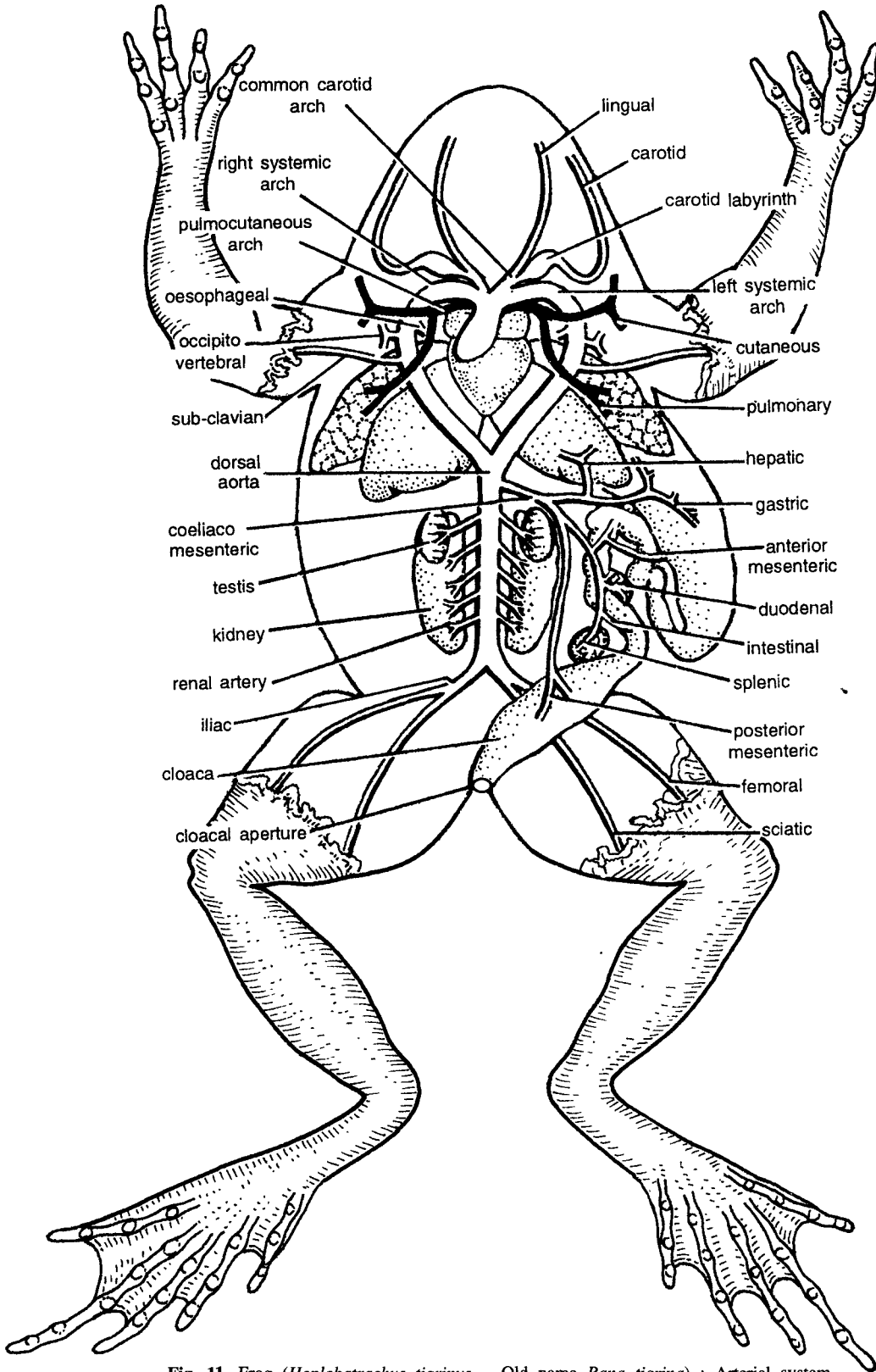

Fig. 11. Frog (*Hoplobatrachus tigrinus* = Old name *Rana tigrina*) : Arterial system.



Each systematic arch gives the following branches :

- (a) **Oesophageal artery.** It supplies to oesophagus.
  - (b) **Occipito-vertebral artery.** It supplies to head, backbone and spinal cord.
- (4) **Dorsal aorta.** The dorsal aorta proceeds backwards and gives the following vessels :
- (a) **Coeliaco-mesenteric artery.** It divides into two. The **coeliac artery** supplies to stomach by **gastric artery** and to liver by **hepatic artery**. The **anterior mesenteric** vessel has 4 branches—a duodenal supplying to duodenum, a **splenic** supplying to spleen, an **intestinal**, and intestine, and a **posterior mesenteric** supplying to large intestine.
  - (b) **Gonadal artery.** It supplies to gonad.
  - (c) **Renal arteries.** They supply to kidneys.
  - (d) **Pelvic artery.** It supplies to urinary bladder.
  - (e) **Iliac arteries.** Each iliac divides into two—a **femoral artery** supplying to outer side of the leg, and a **sciatic artery** supplying to inner side of the leg.

## 6. Frog : Urinogenital System

**Procedure.** *Dissect the frog as usual. Separate the alimentary canal from oesophagus up to the rectum by cutting mesenteries and also cut pubic symphysis to expose the cloaca.*

- (1) **Male frog.** The urinary and genital organs function together. **Urinary system** includes :
- (a) **Kidney.** It is elongated and dark-red coloured with notched edges.
  - (b) **Ureter.** It arises from outer side of kidney and opens into the cloaca. Upper part of seminal vesicle is called as ureter.
  - (c) **Seminal vesicle.** It is formed by the dilation of ureter below kidney. Seminal continues backwards as urinogenital duct and opens into **rectum** and then into **cloaca** which opens to outside as cloacal aperture.
  - (d) **Adrenal gland.** Ventral surface of each kidney has this yellow coloured, elongated gland.
  - (e) **Urinary bladder.** It is a bilobed and thin-walled sac, opening into the floor of the cloaca.
- Genital system** comprises of :
- (a) **A pair of testes.** Attached to anterior end of kidney by mesorchium.
  - (b) **Fat bodies.** Finger-like bodies attached to each testis.
  - (c) **Vasa efferentia.** About a dozen sperm ductules arise from each testis and communicate with collecting tubule of kidney, which opens into the ureter. Other structures seen are fat body, post-caval veins and renal veins.
- (2) **Female frog.** The urinary and genital systems function independently and without any communication with each other. The urinary system is like that of male frog except that there is no dilation of ureter in the form of seminal vesicle. The genital system is on bilateral pattern. On each side it comprises of :
- (a) **Ovary.** Each ovary is lobulated and attached to the kidney by mesovarium. It contains countless ova.
  - (b) **Ostium.** It is funnel-like opening of oviduct into coelom. The ostium leads into a swollen structure called as infundibulum which leads into oviduct.
  - (c) **Oviduct.** Oviduct is coiled tube and it opens into dilated **uterus**.
  - (d) **Uterus.** It is formed by posterior dilated oviduct. Uterus opens into the rectum. Rectum opens outside through cloacal aperture. Other structures seen are lung, urinary bladder and fat bodies.

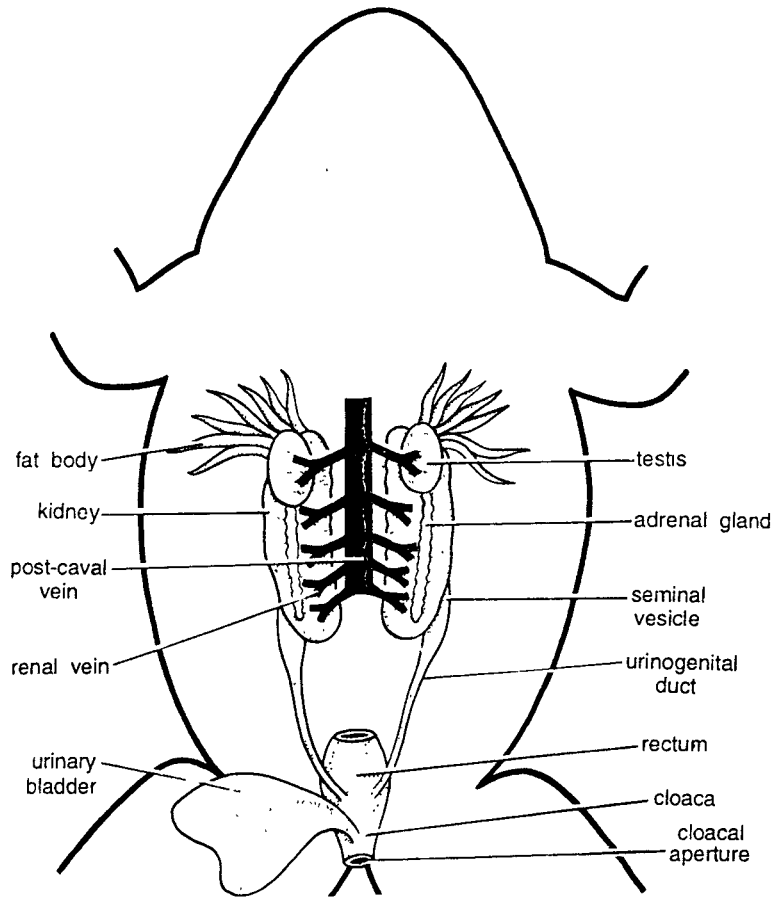

**Fig. 12.** Frog (*Hoplobatrachus tigrinus* = Old name *Rana tigrina*) : Male urinogenital system.

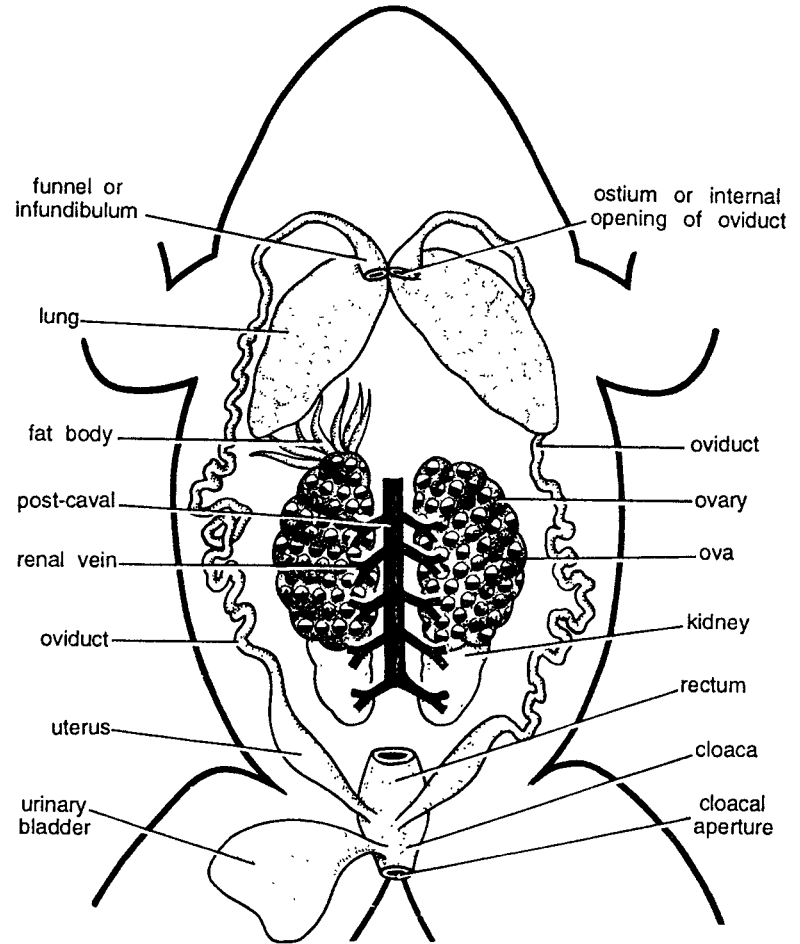

**Fig. 13.** Frog (*Hoplobatrachus tigrinus* = Old name *Rana tigrina*) : Female urinogenital system.

## 7. Frog : Cranial Nerves

**Procedure.** Take anaesthetized frog. On one side remove the flap of skin around cranium upto lower jaw. From cranium 10 pairs of cranial nerves originate and innervate various organs as illustrated in the following chart. Trace the origin and innervation of the cranial nerves around optic lobe.

**Table 1. Cranial Nerves of Frog.**

Name of the Nerve	Originates from	Nature	Innervation
<b>I. Olfactory</b>	Olfactory lobe	Sensory	Nasal sac epithelium
<b>II. Optic</b>	Mid-brain ventrally	Somatic sensory	Retina of eye
<b>III. Oculomotor</b>	Floor of midbrain	Somatic motor	Eye muscles
<b>IV. Pathetic</b>	Between optic lobes and cerebellum.	Somatic motor	Eye muscles
<b>V. Trigeminal</b> It has 3 branches :	Medulla	—	—
(a) <i>Ophthalmicus super facialis</i>	—	Somatic sensory	Skin and snout
(b) <i>Maxillaris internus of V</i>	—	Somatic sensory	Skin and upper jaw
(c) <i>Mandibularis of V</i>	—	Visceral motor	Muscle of lower jaw
<b>VI. Abducens</b>	Floor of medulla	Somatic sensory	Eye muscles
<b>VII. Facial</b> It has 2 branches :	Medulla	—	—
(a) <i>Palatine</i>	—	Visceral motor	Roof of buccal cavity
(b) <i>Hyomandibular</i>	—	Visceral motor	Tongue, lower jaw muscles and face
<b>VIII. Auditory</b>	Medulla	Somatic sensory	Internal ear
<b>IX. Glossopharyngeal</b>	Medulla	Mixed nerve	Tongue, pharyngeal wall
<b>X. Vagus</b>	Medulla	Mixed nerve	General viscera

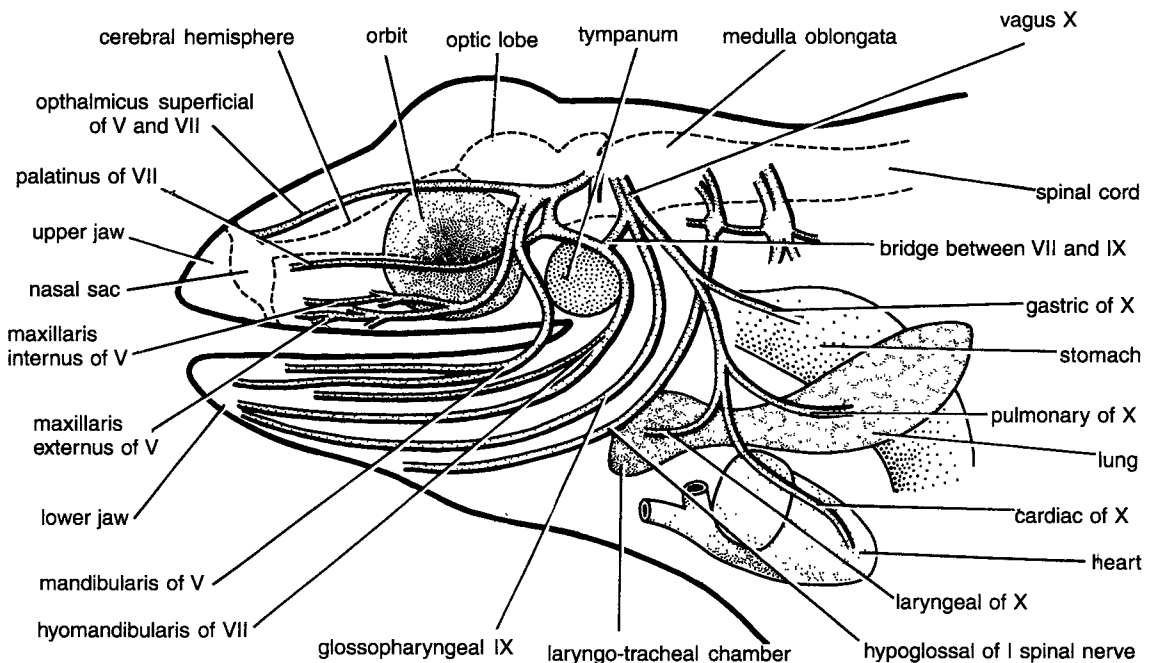

**Fig. 14.** Frog (*Hoplobatrachus tigrinus* = Old name *Rana tigrina*) : Dissection of cranial nerves.

## UROMASTIX : LIZARD

### 1. Lizard : External Features

**Procedure.** Take a freshly-killed specimen and examine the external characters. *Uromastix* is commonly called as 'Sanda'.

- (1) **Size.** It measures 20 to 30 cm in length.
- (2) **Shape.** Typically lizard like.
- (3) **Division.** Body is covered by epidermal scales and regionated into head, neck, trunk and tail.
  - (a) **Head.** It is small with a short snout and contains the following structures :
    - (i) **Nostrils.** The tip of the snout contains two large nostrils.
    - (ii) **Mouth.** It is a large opening, guarded by upper and lower jaws which contain cutting teeth, one in former and two in latter.
    - (iii) **Eyes.** Eyes have two movable eyelids and a nictitating membrane.
    - (iv) **Openings of external ears.** Behind the eyes there are two sunken pits marking openings of external ears. Below each pit is a tympanic membrane, which shows beginning in reptiles of external auditory meatus.
  - (b) **Neck.** It is short.
  - (c) **Trunk.** It is elongated forming major part of the body. It contains 2 pairs of limbs – fore and hind limbs. They are short and primitive and project laterally ending in 5 digits. Each digit contains a horny claw. The thigh region in males contains 12 to 18 pores of femoral glands on ventral surface. These glands produce a secretion, which hardens into temporary **spines** which are used for holding female during copulation.
  - (d) **Tail.** The portion of the body behind cloaca is called tail. The tail is thick and contains about **27 rows of transversely arranged spiny scales**.
- (4) **Hemipenis.** The cloaca has a pair of copulatory hemipenis in male lizard only.

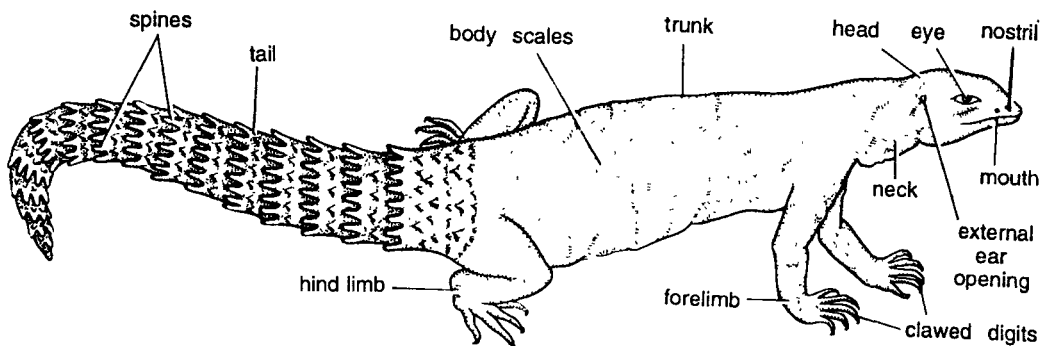

Fig. 15. Lizard (*Uromastix*) : External features.

## 2. Lizard : Arterial System

**Procedure.** Take a *Uromastix* freshly-killed with chloroform, wash it in water and lay it on its back in the dissecting dish. Pin the limbs of the lizard. Cover the dish with water. Make a longitudinal incision through the ventral body wall from the cloacal aperture up to the tip of the snout. Cut the sternum and the pectoral girdle. Also make four cuts, two a little posterior to forelimbs and two opposite the hind limbs. Fix the flaps of the skin by pins. Cut very carefully the connecting membranes so as not to injure any organ and blood vessels. Cut the pericardium and trace the blood vessels, first veins and then arteries.

The blood is distributed to all parts of body by the following arteries:

- (1) **Pulmonary arteries.** The pulmonary aorta originates from the right side of the ventricle and it divides into two pulmonary arteries, each going into a lung. They carry impure blood to lungs.
- (2) **Systemic arches.** The truncus arteriosus divides into right and left systemic arches. Right arch originates from the left side of the ventricle and left arch from the right side. Systemic arches give various arteries.
  - (a) **Innominate artery.** It originates from the right systemic arch, which divides into the **right carotid** and **left carotid arteries**. Each carotid divides into an **internal carotid** and an **external carotid**.
  - (b) **Ductus caroticus.** It joins the internal carotid artery with systemic arch of its side.
  - (c) **Subclavian artery.** It originates from the right systemic arch and divides into right and left **subclavian arteries** which supply to arms. A **vertebral** branch from right subclavian supplies to vertebrae.
- (3) **Dorsal aorta.** The right and left systemic arches unite together forming dorsal aorta, which proceeds backwards to supply by several arteries to viscera as follows :
  - (a) **Oesophageal artery** to oesophagus.
  - (b) **Posterior mesenteric artery** to caecum.
  - (c) **Paired gastric arteries** to stomach.
  - (d) **Gonadial artery** to gonad.
  - (e) **Coeliac artery** to stomach.
  - (f) **Cloacal arteries** to cloaca.
  - (g) **Pancre-hepatic artery** to pancreas and liver.
  - (h) **Renal arteries** to kidneys.
  - (i) **Anterior mesenteric artery** to ileum.
  - (j) **Caudal artery** to tail.
  - (k) **Iliac arteries** to legs.

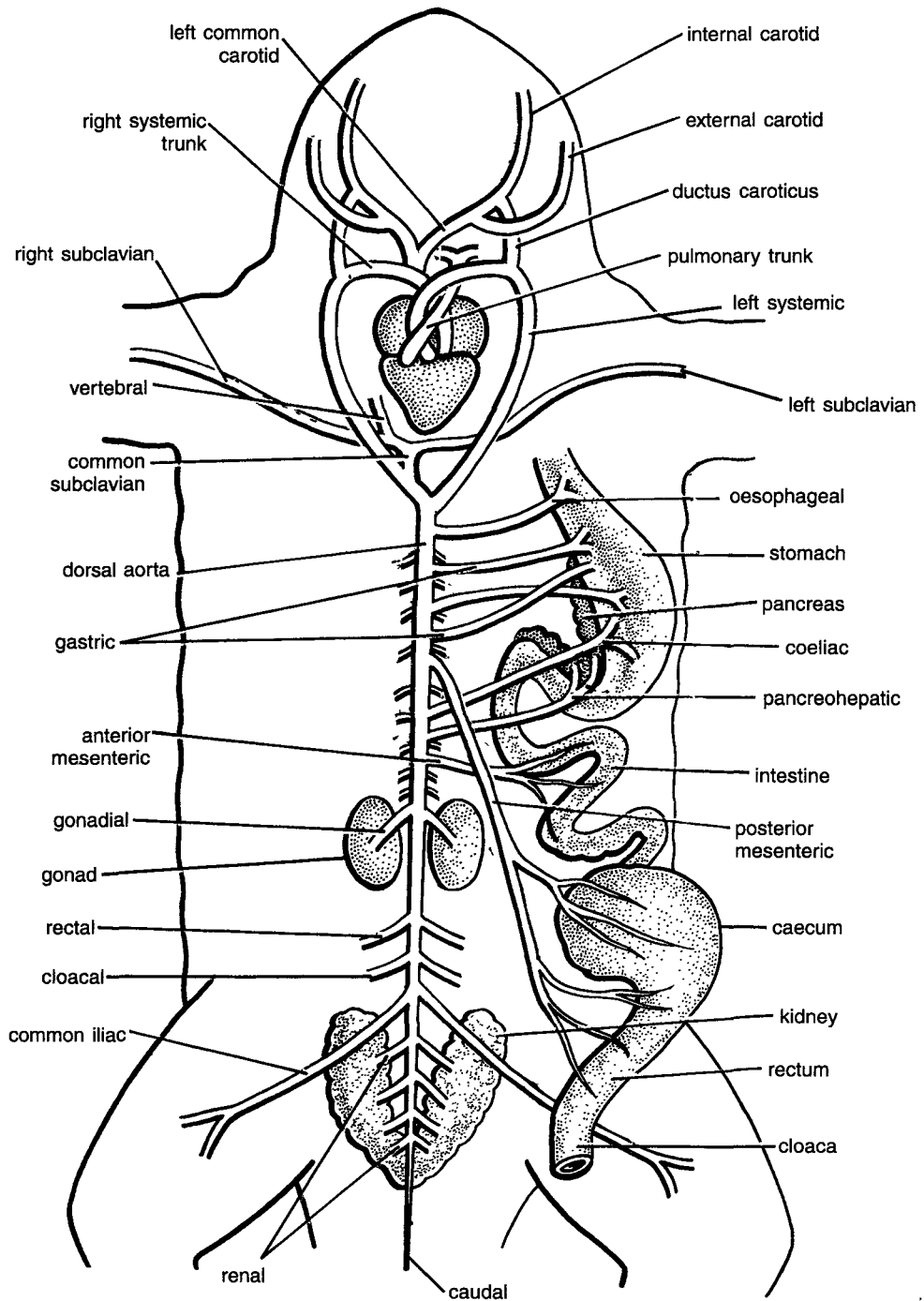

Fig. 16. Lizard (*Uromastix*) : Arterial system.

### 3. Lizard : Venous System

The blood from the entire body is collected by the following veins :

- (1) **Pulmonary veins.** Collect oxygenated blood from lungs. They unite and open into the left auricle.
- (2) **Pre-caval veins.** Each pre-caval vein collects blood from the anterior end, by the following veins :
  - (a) **External jugular.** Collects blood from head.
  - (b) **Internal jugular.** Collects blood from head.
  - (c) **Subclavian.** Collects blood from the arm.

*Note that there is no external jugular on the left side and left pre-caval contains only internal jugular and subclavian. The two pre-cavals enter the bilobed sinus venosus.*

- (3) **Post-caval vein.** The blood from the posterior region is collected by post-caval vein, which pours blood into the sinus venosus. The posterior veins are :
  - (a) **Caudal vein.** Collects blood from tail.
  - (b) **Renal portal vein.** The caudal vein divides into kidney to form **renal portal veins.**
  - (c) **Femoral vein.** Collects blood from outer side of leg.
  - (d) **Sciatic vein.** Collects blood from inner side of leg.
  - (e) **Iliac vein.** It is formed by the union of femoral and sciatic veins.
  - (f) **Pelvic vein.** On each side renal portal and iliac veins unite to form a pelvic vein. It also receives adipose vein from fat bodies.
  - (g) **Anterior abdominal vein.** The two pelvis imperfectly unite together to form anterior abdominal vein, which opens into the left lobe of the liver. Anterior abdominal continues towards heart as post abdominal and collects blood from heart by **cardiac vein.**
  - (h) **Renal sinus vein.** The capillaries in the kidney unite to form renal sinus vein, which extends forwards as **efferent renal trunk.**
  - (i) **Post-caval vein.** The two efferent renal trunks unite together below gonad and form the post-caval vein. The post-caval vein, after receiving a wide **hepatic vein** from the liver, is continued upwards and opens into the sinus venosus.
- (4) **Hepatic portal system.** It is formed by the following veins :
  - (a) **Gastric vein** from stomach.
  - (b) **Intestinal vein** from intestine.
  - (c) **Duodenal vein** from duodenum.
  - (d) **Splenic vein** from spleen.
  - (e) **Pancreatic vein** from pancreas.

These veins unite to form the hepatic portal vein, which joins with abdominal vein and enters the liver, where it breaks into capillaries forming hepatic portal system.

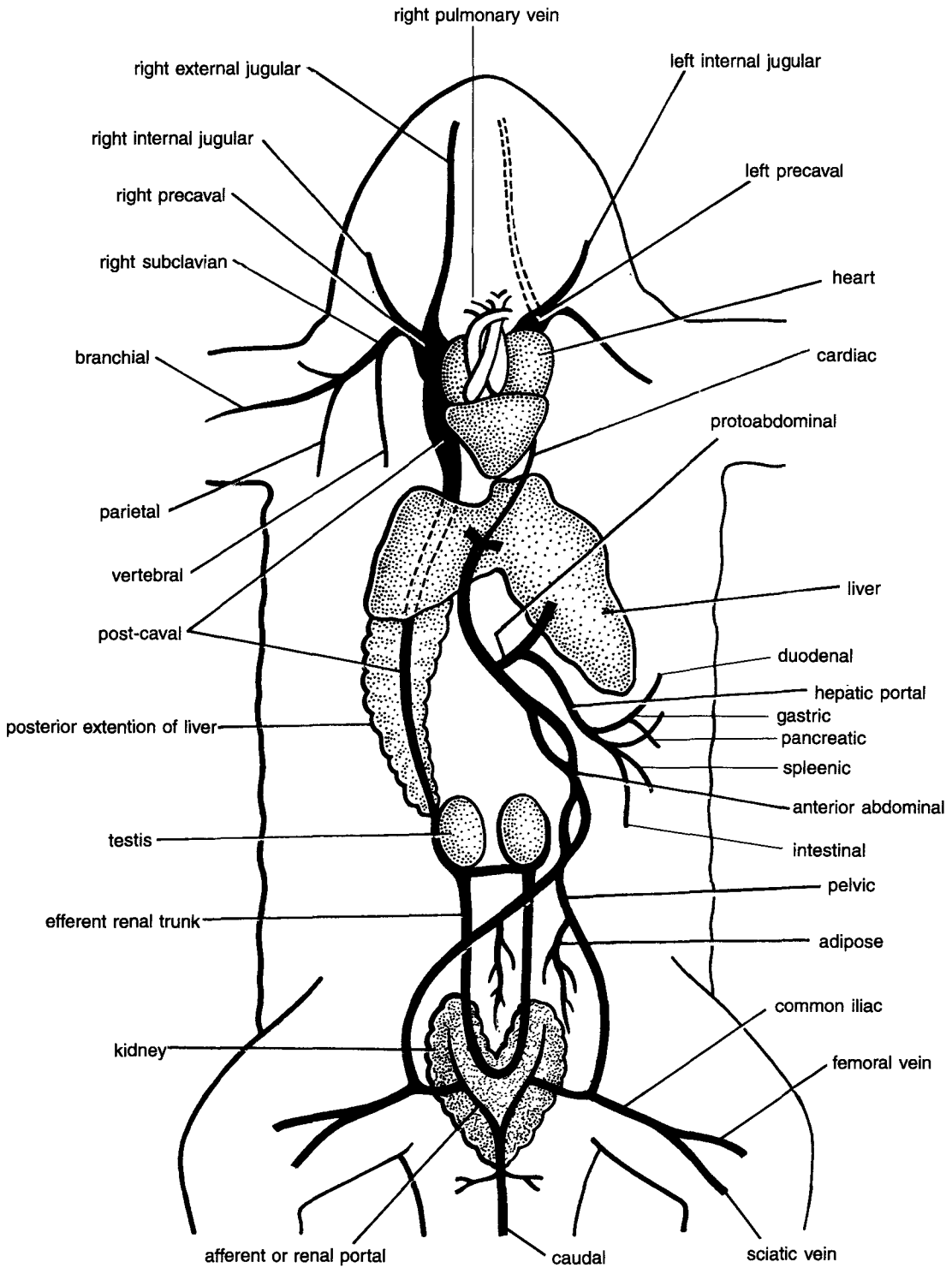

Fig. 17. Lizard (*Uromastix*) : Venous system.



## SNAKE : BITING MECHANISM IN VIPER

### Comments :

- (1) Biting mechanism involves two main events : (i) Erection of fangs and (ii) Injection of poison into victim's body. For instance when a viper wants to strike, a series of movements occur in a chain.
- (2) **Digastric muscles contract, mandible** is lowered, mouth opens and lower end of **quadrate** thrusts forward.
- (3) **Pterygoid** is pushed forward with the contraction of **sphenopterygoid muscles**.
- (4) Pterygoid in turn pushes **ectopterygoid** upwards on to which maxilla bearing **fangs** and accessory fangs rotates through 90° at the hinge joint with lacrimal protractor pterygoid muscles help in biting mechanism.
- (5) As a result of above movements, **fangs** become **erect** and in most effective position to strike. During bite, fangs embed in victim's skin and tissues. Simultaneously stretching of constrictor muscles around the poison gland forces its poison into the victim through poison duct and fang.
- (6) After injection of poison, **temporal muscles** contract and all movements are reversed. Fangs rotate and become horizontal and withdrawn into mouth cavity. Mouth of the snake is closed.
- (7) Other bones seen are premaxilla, nasal parietal, frontal, squamosal, columella and palatine.
- (8) Best treatment of snake bite is injection of antivenom serum (= antivenin) into the victim to counteract ill effects of snake poison (venom).

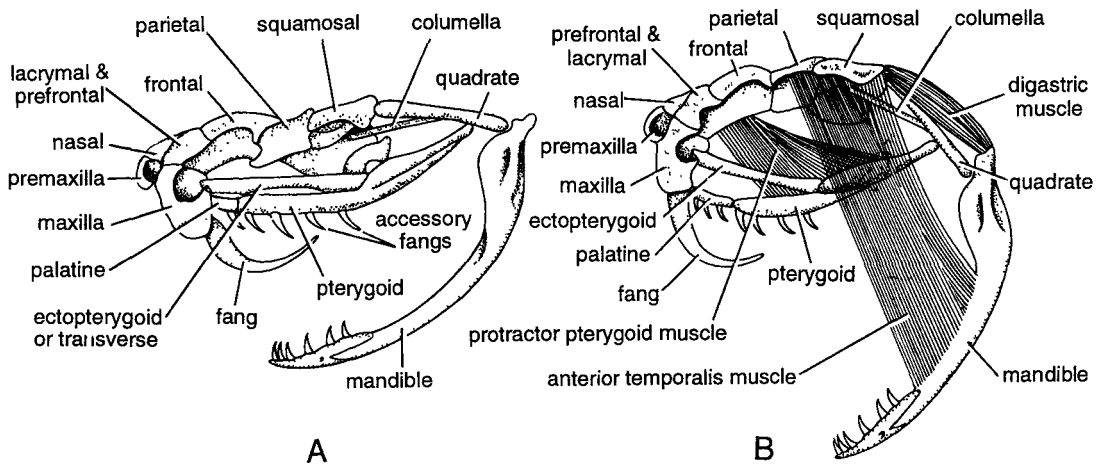

**Fig. 18.** Viper : Biting mechanism.

## COLUMBA LIVIA DOMESTICA : ROCK PIGEON

### 1. Rock Pigeon : External Features

In order to study external morphology, take freshly chloroformed pigeon. Note that entire body, except the beak and feet, is covered by feathers. Body is regionated into **head, neck, trunk and tail**. The size and colour of the body vary in different species and varieties.

(1) **Head.** It contains several structures :

- (a) **Beak or bill.** It is strong, horny, straight and pointed. At the base of the beak is a naked swollen portion of sensitive skin called **cere**.
- (b) **External nares or nostrils.** These are obliquely situated in the cere.
- (c) **Eyes and eyelids.** Each eye is large and rounded.
- (d) **External auditory aperture.** It is posterior to each eye and is covered by backwardly directed feathers, the **auriculars**.

(2) **Neck.** It is long, flexible and S-shaped. Ventral part of neck is called as throat.

(3) **Trunk.** It constitutes major part of the body. It is divided into a large **thorax** and a small **abdomen**. The thorax is strengthened ventrally by the large **sternum**, from which projects **carina** or **keel**. The keel is seen and felt as a prominent ridge. Trunk contains 2 pairs of **limbs**.

(a) **Forelimbs.** These are modified into **wings**. Each wing is divided into the **upper arm, forearm and hand**.

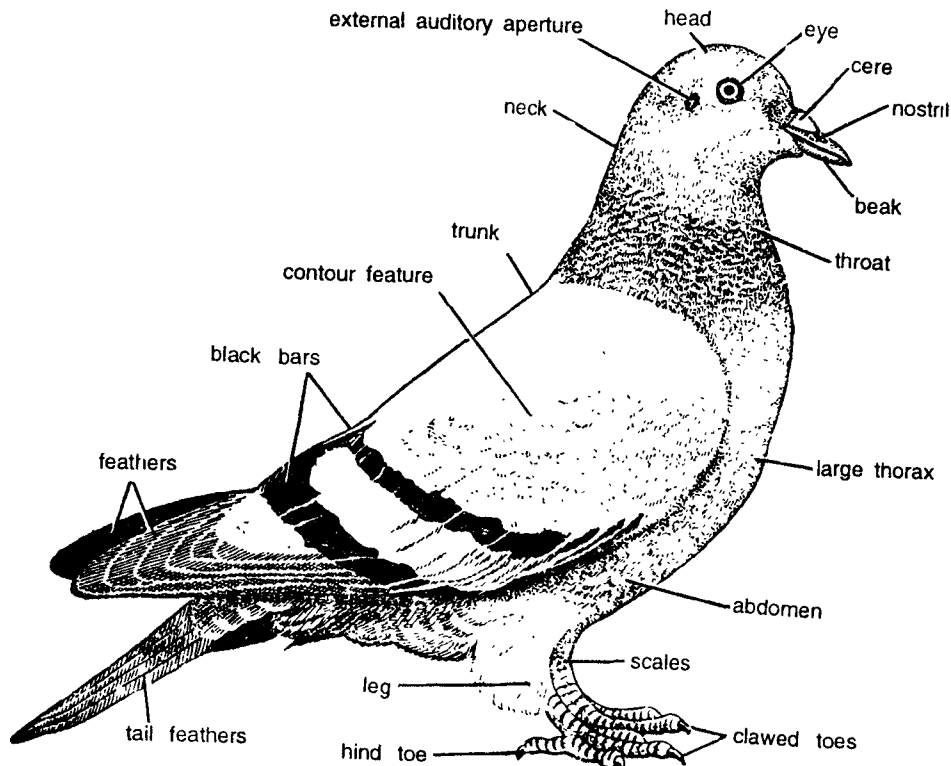

Fig. 19. Rock pigeon (*Columba livia*) : External feature.

(Z-21)

- (b) **Hind limbs.** They support the body and are modified for bipedal locomotion. The hind limbs contain horny scales and each digit has a horny **claw**.
- (4) **Tail.** The region behind **cloaca** is called tail. The dorsal surface of the tail contains a **uropygial gland** secreting **oil**. Squeeze this gland and note oil oozing from it. The oil is used to dress or preen its feathers.
- (5) **Feathers.** Feathers cover more or less the entire body. They are of three kinds :
- (a) **Contour feathers.** They cover the surface of the body consisting of **wing feathers** and **contour feathers**. The strongest contours are the **quill feathers**. The quill feathers of wings are called **remiges** and of tail as **rectries**. The remiges attached to bones of **hand** are called **primaries** and to **ulna** as **secondaries**. A small bunch of feathers is attached to the first pre-axial digit called **alaspuria** or **bastard wing**.
- (b) **Hair-feathers or filoplumes.** These are very thin, hair-like and degenerate feathers, situated at the base of the contour feathers.
- (c) **Down feathers.** They are found below contour feathers and do not contain hooks on the barbules.

## 2. Rock Pigeon : General Anatomy

**Procedure.** Kill the pigeon by chloroform. Remove the feathers by plucking them. After complete defeathering, lay the pigeon on its back on the dissecting dish. Cut longitudinally the abdominal wall from the cloaca. By strong scissors make a cut through the sides of sternum along its attachment to the ribs and lift the sternum with the fingers, so as not to injure the internal organs. Disarticulate the coracoids from the sternum and also cut the furcula at the two clavicles. The sternum can be detached to expose fully the underlying organs. Draw diagrams of organs seen in situ.

- (1) **Bucco-pharyngeal cavity.** It consists of :
- (a) **Horny beak.** Consisting of upper and lower beaks enclosing mouth.
- (b) **Internal nares.** These are slit-like openings, lying close together in the roof.
- (c) **Eustachian opening.** It is a single aperture found just behind the internal nares.
- (d) **Tongue.** It is triangular and pointed.
- (e) **Glottis.** It lies posterior to the tongue.
- (2) **Digestive system.**
- (a) **Oesophagus.** It is large, wide and elongated and it opens into stomach. It extends through neck dorsal to trachea and forms a **crop** in the middle.
- (b) **Stomach.** It comprises of a small digestive **proventriculus** and a large mechanical **gizzard** which is highly muscular.
- (c) **Intestine.** Stomach leads into the intestine, which is differentiated into the **duodenum**, **ileum** and **rectum**. Rectum opens to outside by cloacal aperture.
- (d) **Associated glands and other structures.** These comprise of **liver**, **pancreas** and **spleen dorsal aorta**, **bile ducts**, **pancreatic ducts**, **Bursa Fabricii**, **ureter**, **left kidney**, **gizzard**, **proventriculus**, **spleen**, **left lung**, **heart pectoralis major muscles** and **thymus gland**.
- (3) **Respiratory system.** It consists of :
- (a) **Upper larynx.** It opens into the pharynx by glottis.
- (b) **Trachea.** It is situated ventral to the oesophagus and is supported by partially ossified rings. The trachea leads into **right** and **left lungs** and **air sacs** by bronchii. .
- (4) **Air sacs.** Insert a blow pipe in trachea and inflate the air sacs. Tie a thread in trachea and examine the following in air sacs :
- (a) **Cervical air sacs.** Two, found at the base of the neck.
- (b) **Interclavicular air sac.** It is a single air sac, found between the two clavicles.

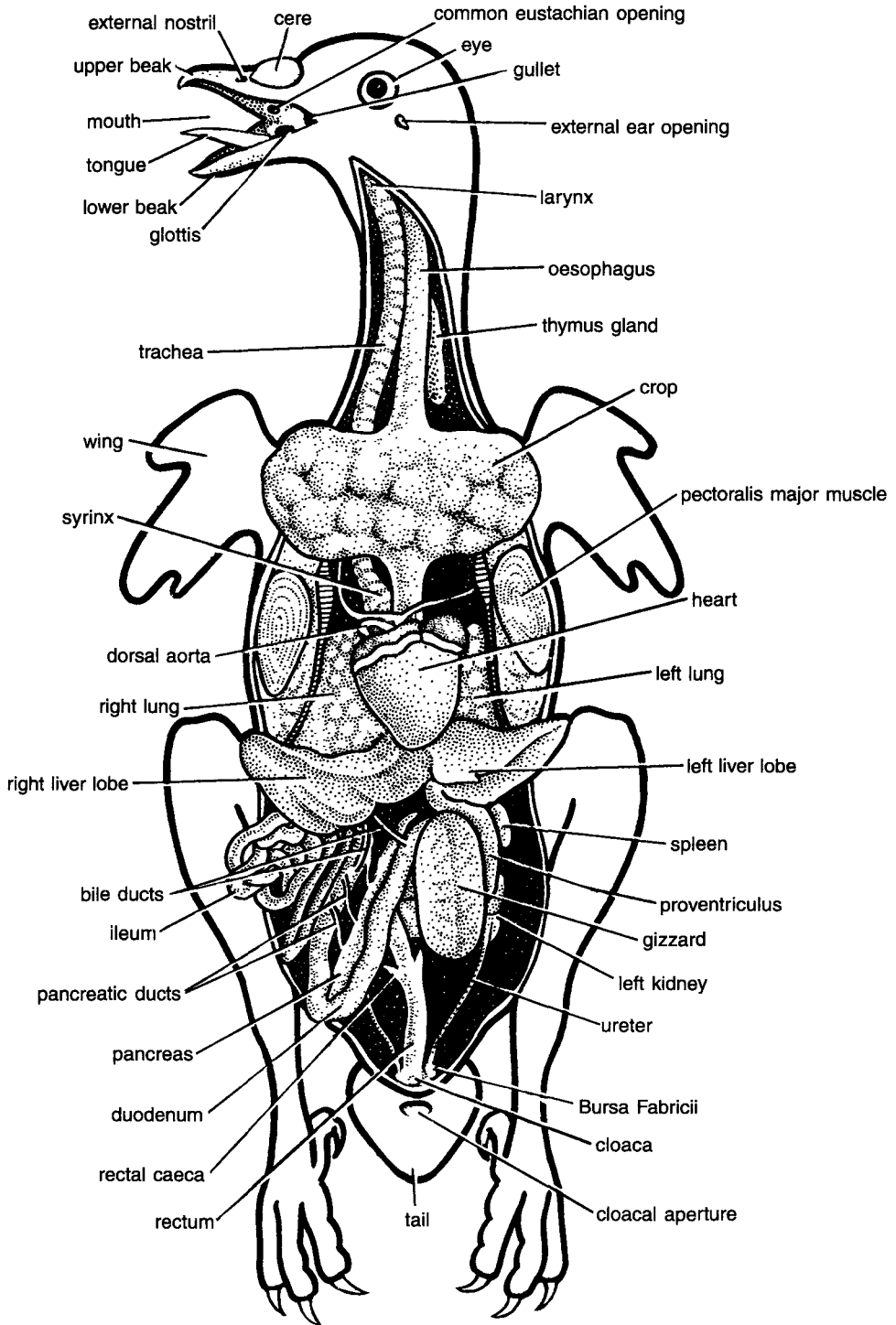

Fig. 20. Rock pigeon (*Columba livia*) : Dissection of general anatomy.

- (c) **Anterior thoracic air sacs.** Two in number, covering the ventral surface of the anterior parts of the lungs.
- (d) **Posterior thoracic air sacs.** Two in number, lying on the posterior parts of the lungs.
- (e) **Abdominal air sacs.** Two in number. These are the largest and found dorsal to intestine.

### 3. Rock Pigeon : Flight Muscles

**Procedure.** In a defeathered pigeon, fixed in a dissecting dish, make a longitudinal incision in the skin from the cloacal aperture up to the lower beak. From the ends of the longitudinal incision cut the skin along the wings and pin up the flaps of skin or remove it by cutting. Also cut through the origin of pectoralis major by the side of keel, the posterior edge of sternum and the clavicle and from the underlying muscles. Study the following flight muscles :

- (1) **Pectoralis major.** It originates from whole of the keel from the posterior part of the sternum and clavicle. Its flat tendon is inserted on the deltoid ridge of the humerus. Pectoralis major lowers the wing during flight. Hold the pigeon in your hand, pull the pectoralis major muscle and see how the wing is lowered.
- (2) **Pectoralis minor.** It overlaps the pectoralis from the dorsal part of the keel of sternum and the inner part of the ventral surface of the sternum. The **tendon**, formed by its fibres, passes through the **foramen triosseum** and is inserted on the dorsal surface of the humerus. Pectoralis minor raises the wings.

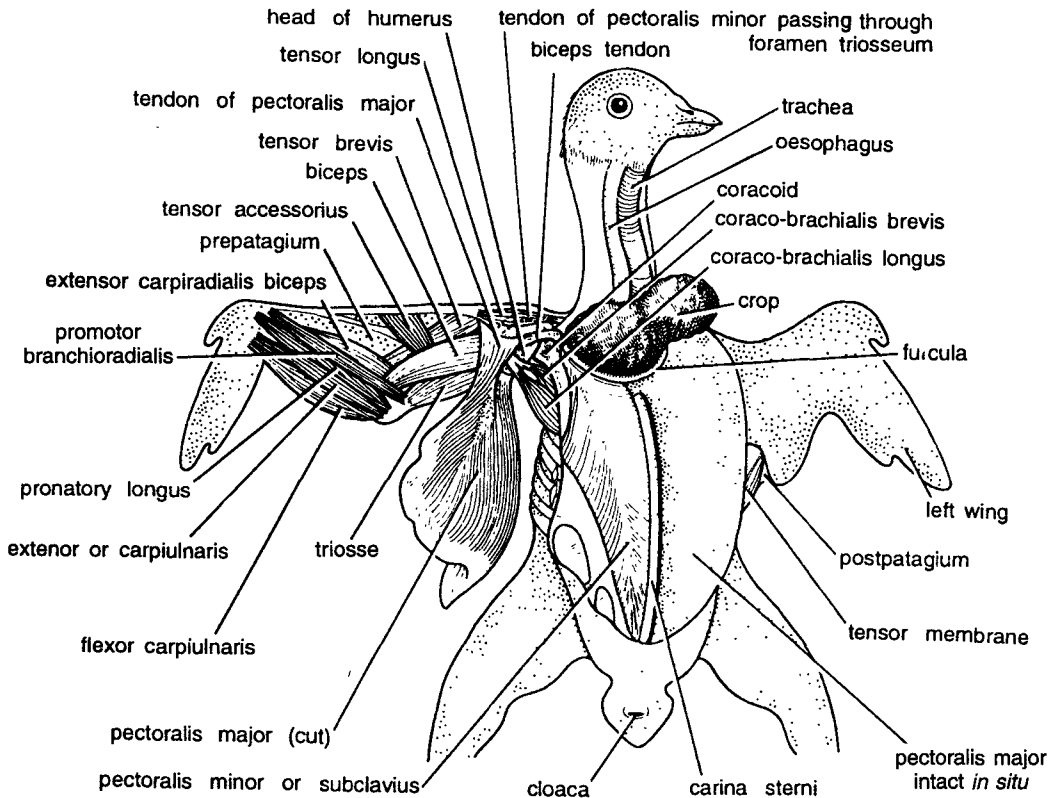

Fig. 21. Rock pigeon (*Columba livia*) : Flight muscles on the right side of the body.

- (3) **Coraco-brachialis longus and coraco-brachialis brevis.** They originate from the coracoid and scapula and are inserted on the head of the humerus, to rotate the wings in glenoid cavity.
- (4) **Tensor longus, tensor brevis and tensor accessorius.** These hold the pre-patagium tensely stretched during flight.
- (5) **Tensor posterioris alae.** It keeps the post-patagium tensed. Other muscles associated with the flight are **flexor carpiulnaris, extensor carpiulnaris, pronator longus, pronator brachioradialis, extensor carpiadialis biceps.**
- (6) Other structures seen are biceps, head of humerus, tendon of pectoralis minor passing through foramen triosseum, trachea, oesophagus, coracoid, crop, fercula, left wing, post, patagium, carina sterni and cloaca.

#### 4. Rock Pigeon : Venous System

**Procedure.** Remove the pericardium and also cut away the fat and connective tissues at the base of the heart to expose the heart and blood vessels.

**Heart.** It is four-chambered, consisting of **two auricles** and **two ventricles.**

**Veins.** The blood from all parts of the body is collected by the following veins :

- (1) **A pair of pulmonary veins.** Two in number. They bring oxygenated blood from the lungs into the left auricle.
- (2) **A pair of pre-caval veins.** Each pre-caval is formed by :
  - (a) **Jugular vein.** Collects blood from the head. The right and left jugular veins unite in the neck by the **inter-jugular transverse anastomosis.** Both right and left jugular veins in middle give rise to right and left vertebral respectively which collect blood from vertebrae.
  - (b) **Subclavian vein.** It receives a branch, the **brachial,** from the wing and a very large **pectoral vein** from the flight muscles.
- (3) **The post-caval vein.** It collects blood from the posterior part of the body and comprises of the following veins :
  - (a) **Caudal vein.** Collects blood from tail.
  - (b) **Renal portal or hypogastric vein.** The caudal vein bifurcates into two renal portal veins, which pass over the kidneys. Each renal portal vein receives :
    - (i) **Internal iliac.** Collects blood from the pelvic region.
    - (ii) **Renal veins.** From the kidney.
    - (iii) **Femoral vein.** From outer side of leg.
    - (iv) **Sciatic vein.** From inner side of leg.
  - (c) **Common iliac veins.** The above veins and renal portal vein on each side unite to form a **common iliac vein.** The common iliac veins of two sides unite together to form the **post-caval vein,** which receives **hepatic vein** from the liver and enters directly into the right auricle.
- (4) **Hepatic portal vein.** It collects blood from the intestine and it also receives a branch from the caudal vein called **coccygeo-mesenteric vein.** The hepatic vein also receives an **epigastric vein** from the peritoneum.

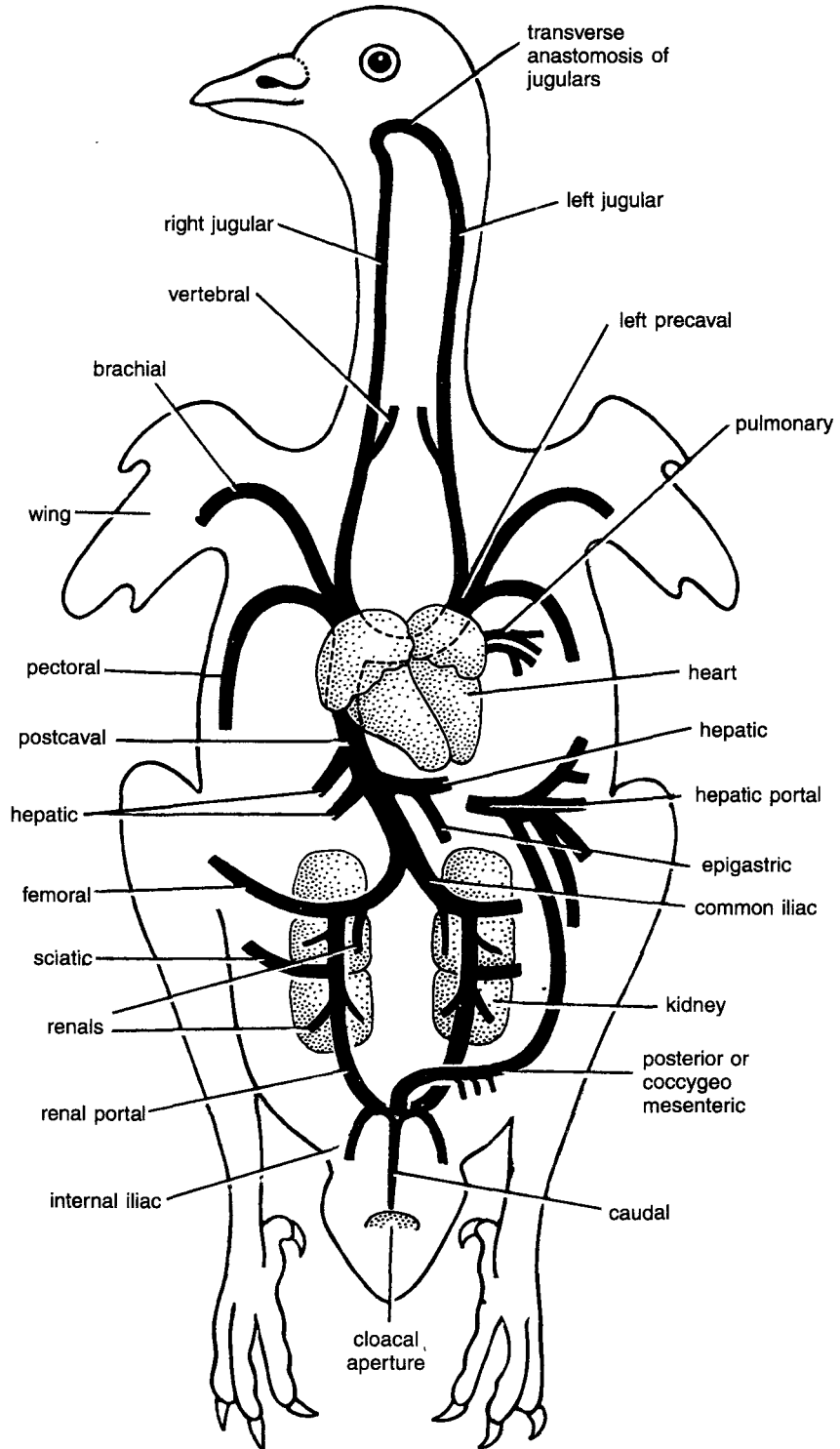

Fig. 22. Rock pigeon (*Columba livia*) : Venous system.

## 5. Rock Pigeon : Arterial System

The following arteries supply blood to various parts of body. **Conus arteriosus** and ventral aorta divide to form **pulmonary aorta** and **right systemic arch**.

- (1) **Pulmonary arteries.** The pulmonary aorta divides into two pulmonary arteries, which carry deoxygenated blood to lungs, one on each side.
- (2) **Right systemic arch.** In birds only right systemic arch persists in the adult. It originates from the left ventricle and gives several arteries :
  - (a) **A pair of innominate arteries.** On each side, right systemic arch gives an **innominate artery** which gives two branches :

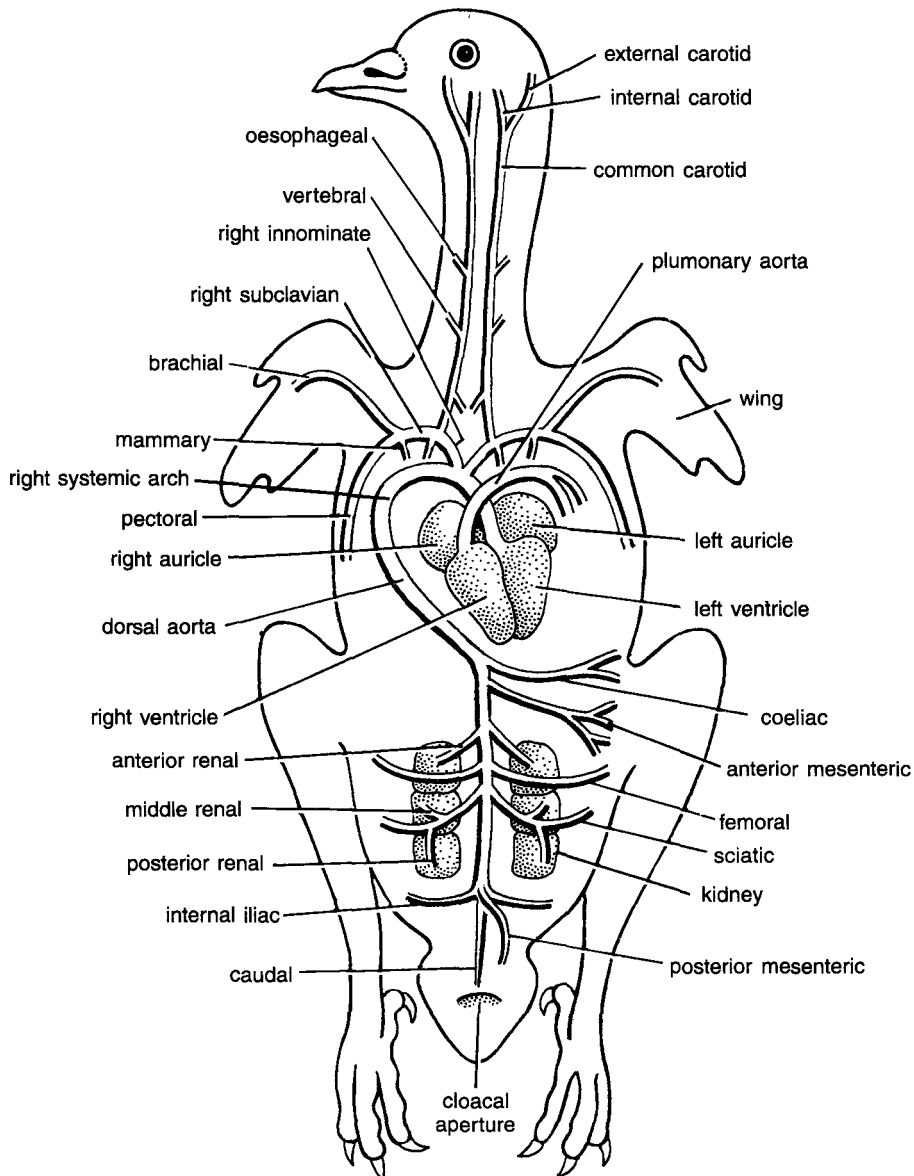

Fig. 23. Rock pigeon (*Columba livia*) : Arterial system.



- (i) *Carotid artery*. It extends upwards and divides into **external carotid** and **internal carotid** to supply to the head.
  - (ii) *Subclavian artery*. It divides into **brachial artery**, which supplies to the wing, and **pectoral artery**, which supplies to the pectoral muscles of the flight.
- (2) **Dorsal aorta**. The right systemic arch bends over the heart and continues to posterior end as **dorsal aorta**, giving the following arteries :
- (a) *Coeliac artery*. It supplies to stomach and liver.
  - (b) *Anterior mesenteric artery*. It supplies to small intestine.
  - (c) *Renal arteries*. They supply to kidneys.
  - (d) *A pair of femoral arteries*. They supply to outer side of legs.
  - (e) *A pair of sciatic arteries*. They supply to inner side of legs.
  - (f) *Iliac arteries*. They supply to the hip region.
  - (g) *Posterior mesenteric artery*. It supplies to the large intestine.
  - (h) *Caudal artery*. It supplies to the tail.

### BIRD : PERCHING MECHANISM

#### Comments :

Perching means firmly grasping a branch of tree. Perching mechanism involves special arrangement of **muscles** and **tendons** in upper part of leg such as :

- (1) **Flexor muscles**. 6 anterior toe flexors and 2 posterior toe flexors. Different flexors are **ambiens**, **peroneus medius**, **gastrocnemius** and **flexor perference**. Flexor tendons pass behind the shank over the heel, then they pass through annular ligament behind foot to different toes and phalanges. Their function is to **flex** or close the toes.
- (2) **Extensor muscles**. Several extensor muscles are found in front of the tibiotarsus. Their tendons pass down in front of intertarsal joint and then trifurcate to supply one branch to each anterior toe. Their contraction serves to open the toes.

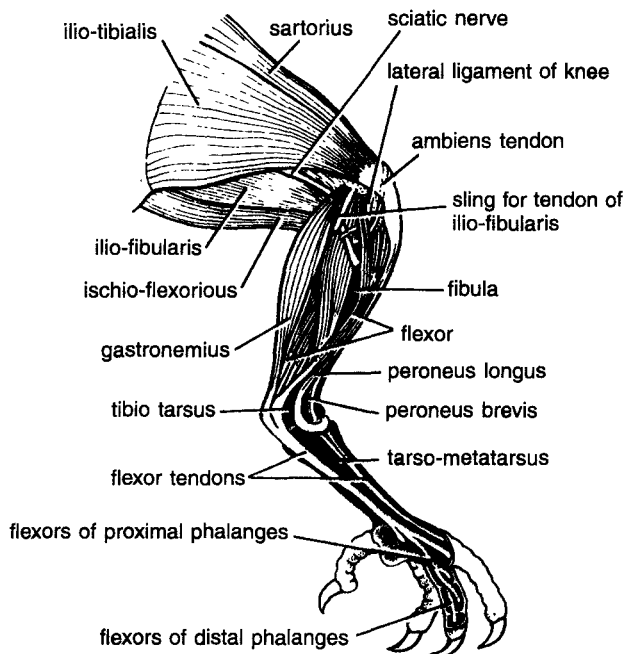

Fig. 24. Rock pigeon (*Columba livia*) : Leg showing dissection of perching mechanism.

**RATTUS RATTUS : RAT****1. Rat : External Features**

The rat is a typical mammal due to the presence of mammary glands and hairs. Rat is also a **quadruped** because all the four limbs touch the ground.

**Procedure.** For external features first kill the rat with chloroform and then immerse it in a solution of lysol or any antiseptic solution. Lay the rat in a dissecting dish keeping ventral surface upwards. Note the following structures :

- (1) **Size.** About 25 cm including tail.
- (2) **Shape.** Body is elongated and brownish in colour.
- (3) **Division.** Entire body is regionated into the **head, neck, trunk and tail.** The hairs or **pelages** cover and protect the entire body.
  - (a) **Head.** The head is elongated and somewhat conical in shape, tapering anteriorly to **terminal nose.** Head has the following structures :
    - (i) *A pair of nostrils or nares.* They are found in front of the nose and lead into the nasal passages. Nostrils can be closed under water. Just below the nose hair like processes called in **vibrissae** present.
    - (ii) *Hairlip.* A cleft is found below the nostrils in upper lip and it exposes the two upper incisors.
    - (iii) *Mouth.* It is found in a sub-terminal position of the head and leads into the buccal cavity.
    - (iv) *Teeth.* There are 4 **incisors** and **molars.** Canines and premolars are absent. The two front incisor teeth are long and they grow throughout the life of rat. These are cutting teeth and form characteristic feature of the order Rodentia to which rat belongs. The incisor teeth are self-sharpening and chisel-like.
    - (v) *Eyes.* Two, one on each side. The eyes are small. Each eyelid and a portion of **cornea** somewhat protrudes through the eyelids to give side vision. The external eyelid has **lacrymal glands,** the secretion of which keeps the eye moist. A **nictitating membrane** is attached to anterior cornea of each eye.
    - (vi) *External ears or pinnae.* These are found on the postero-lateral area of the head.
  - (b) **Neck.** It is a short region connecting the head to the body or trunk.
  - (c) **Trunk.** It contains **thoracic, abdominal and pelvic areas.** In **females,** one pair of **thoracic nipples** 2 pairs of **axillary nipples,** one pair of **abdominal nipples** and 2 pairs of **inguinal nipples** are seen on ventral surface. The **urethral orifice, vulval** opening and **anus** lie close together in pelvic region. In **males,** there are two large testes in the **scrotal sacs.** The trunk region also contains **forelimbs** and **hind limbs.**
  - (d) **Fore limb contains elbow, brachium, antebrachium, carpus** and **manus.** A vestigial thumb in also seen. **Hind limb** is composed off knee, shank, heel tarsus and pes.
  - (e) **Tail.** It acts as a balancing organ. At its beginning it contains small overlapping vestigial scales.

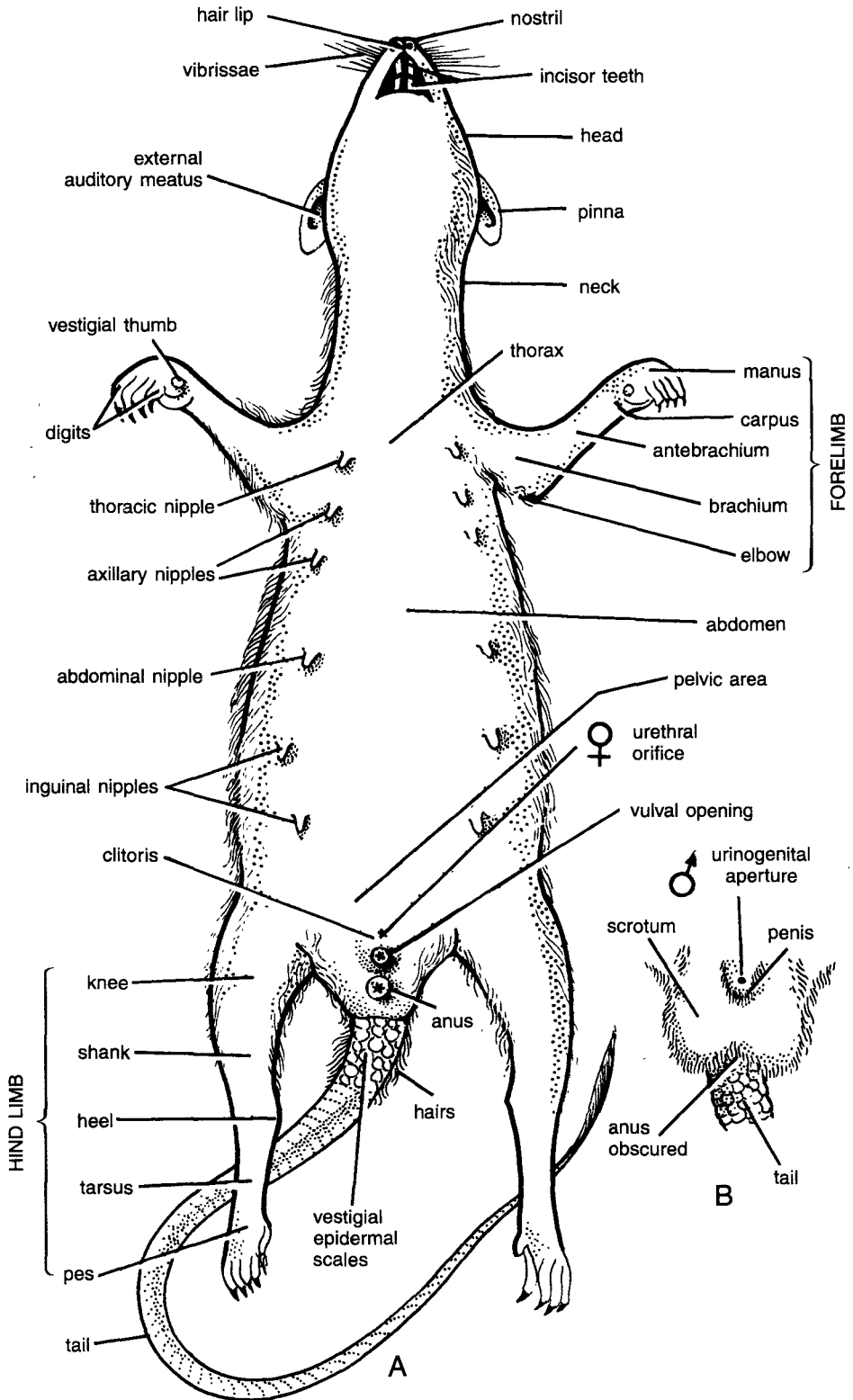

Fig. 25. Rat (*Rattus rattus*) : External features. A. Female rat in ventral view, B. Pelvic region of male rat in ventral view.

## 2. Rat : General Anatomy

**Procedure.** (1) Kill the rat with chloroform, immerse it in any antiseptic solution and lay it on its back on the dissecting board. Fix the limbs with pin.

(2) Make a longitudinal slit in the skin from the pubic symphysis to the tip of the snout and make transverse cuts at the ends of longitudinal cut. Separate the skin from the muscular body wall. They are connected together by loose subcutaneous connective tissue. Note the presence of mammary glands in the female. Make a longitudinal incision in the abdominal wall from the pubic symphysis to xiphisternum, cut parallel to the ribs on both the sides and reflect the abdominal wall. Dissect neck region to expose the blood vessels and nerves. Expose and see various glands and organs.

(1) **Digestive system.** It consists of :

(a) **Mouth.** It leads into the **buccal cavity**, which contains teeth and tongue.

(b) **Pharynx.** It is a chamber between the mouth and oesophagus. It acts as a common passage for food and air. It channels food into the alimentary canal and air in trachea through glottis.

(c) **Oesophagus.** It is a short tube found just below the wind pipe.

(d) **Stomach.** Oesophagus leads into the pear-shaped stomach, divided into **cardiac** and **pyloric** parts.

(e) **Intestine.** Stomach leads into small intestine, which is divided into **duodenum**, **jejunum** and **ileum**. **Colon** arises from the junction of the small intestine and large intestine. The first part of colon is called as **caecum**, while its terminal end is called as **vermiform appendix**.

(f) **Rectum.** The large intestine or rectum opens to exterior by anus.

(g) **Associated glands**

(i) **Salivary glands.** Three pairs of these are found in buccal cavity. They secrete saliva.

(ii) **Submaxillary salivary glands.** The largest of three pairs are found on the ventral surface of the neck from the point of the jaw to the manubrium of the sternum. Their ducts open at the base of the incisors.

(iii) **Sublingual salivary glands.** They are found on the sides of the submaxillary glands and pour their secretion under the tongue.

(iv) **Paratoid salivary glands.** They are found behind and below the bases of the ears on ventro-lateral surface of the neck.

(v) **Thymus and thyroid glands.** These are endocrine glands.

(vi) **Liver.** It is composed of four lobes.

(vii) **Pancreas.** It is also an endocrine gland, suspended by delicate mesenteries between the stomach and the duodenum.

(2) **Heart.** It lies in pericardium and is composed of 2 auricles and 2 ventricles.

## 3. Rat : Venous System

The blood from the entire body is collected by the following veins :

1. **A pair of pulmonary veins.** They carry oxygenated blood from lungs to the left auricle.

2. **A pair of precaval veins.** These collect blood from the anterior body. Each precaval comprises of:

(a) **Jugular veins.** It divides into two :

(i) **Right and left external jugular veins.** It collects blood from lower jaw. Both right and left external jugular collect blood from face by following veins (a) Right anterior facial and left anterior facial, (b) Right posterior facial and left posterior facial, (c) Right and left cephalic veins.

(ii) **Right and left internal jugulars.** It collects blood from the brain. It joins with external jugular.

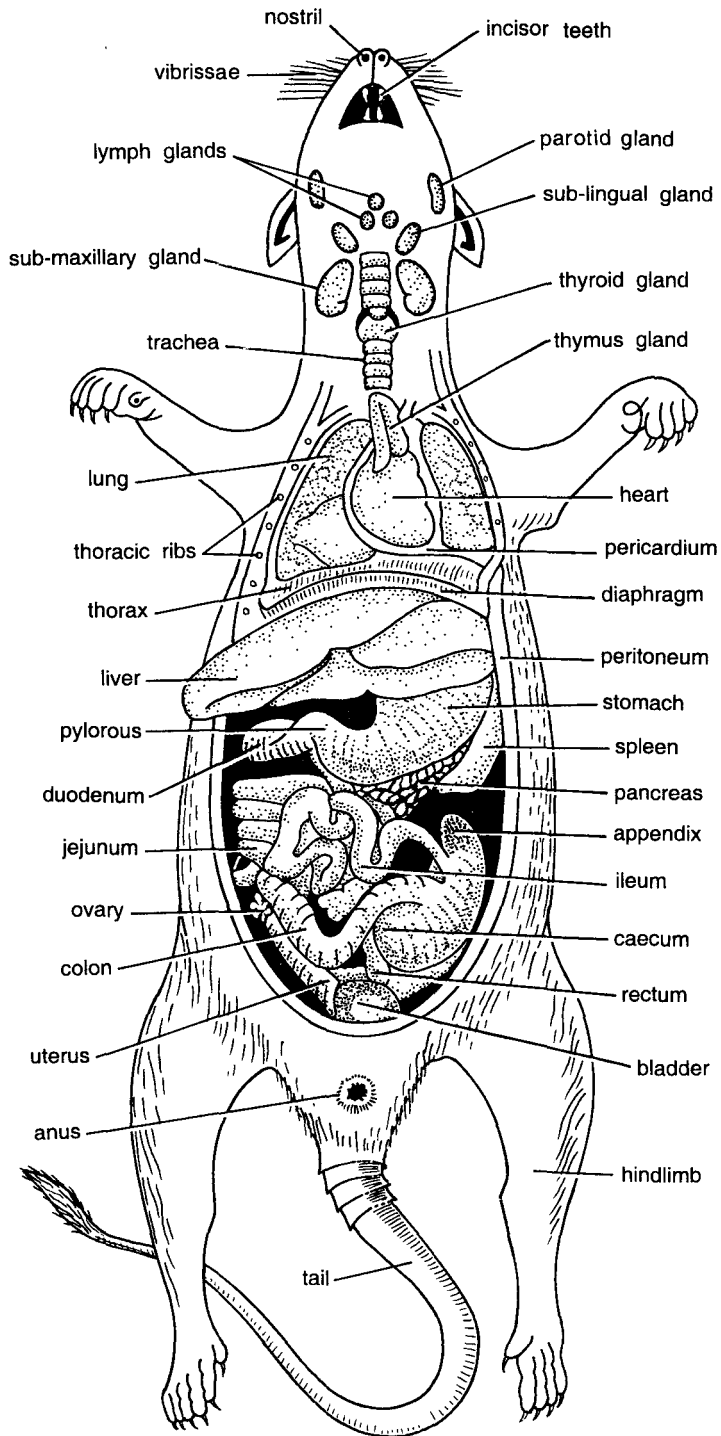

Fig. 26. Rat (*Rattus rattus*) : Dissection of general anatomy.

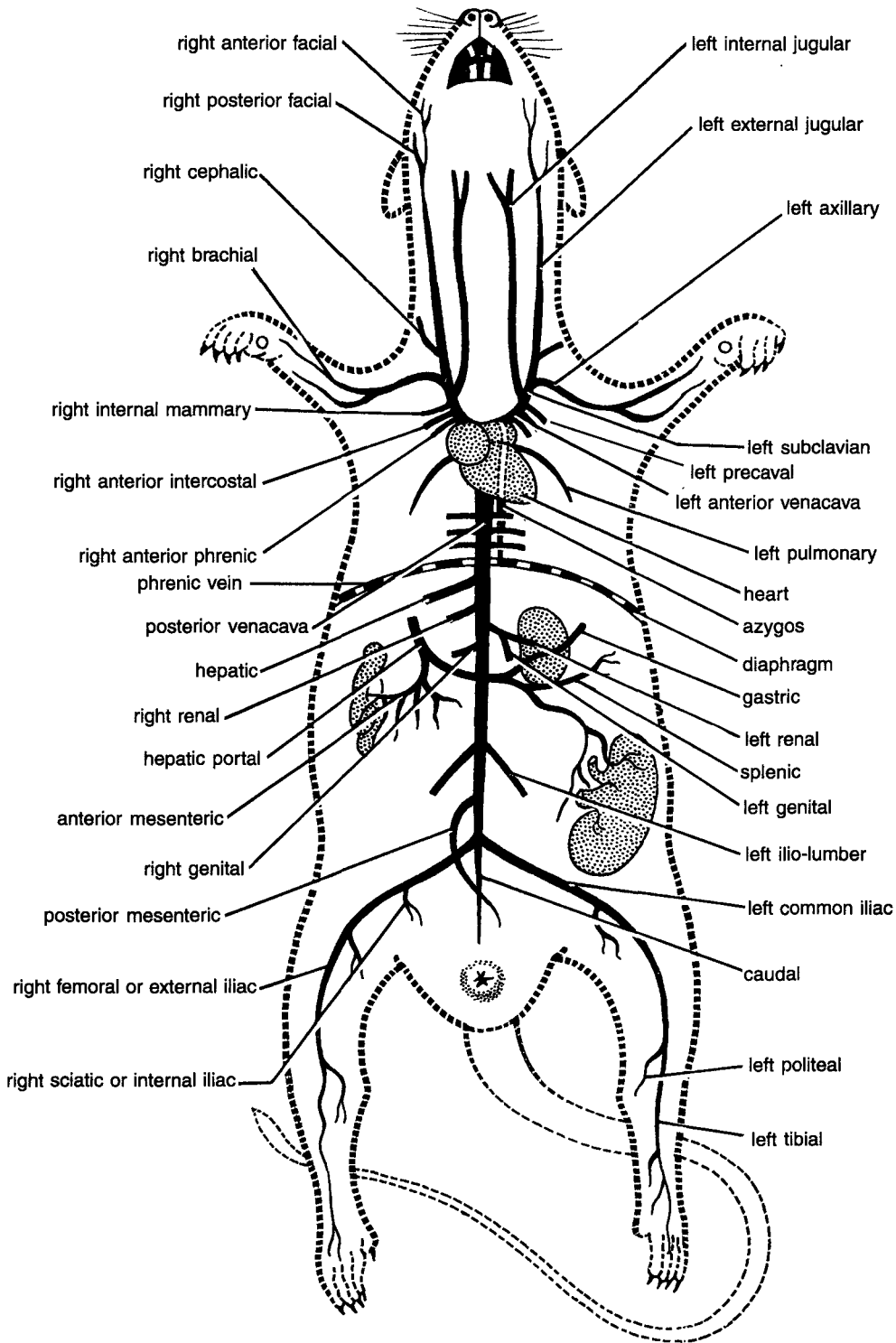

Fig. 27. Rat (*Rattus rattus*) : Venous system.

- (b) **Right and left subclavian veins.** It collects blood from forelimb and opens into precaval vein.
  - (c) **Right and left anterior intercostal veins.** It collects blood from intercostal spaces and opens into precaval vein.
  - (d) **Right and left internal mammary veins.** It collects blood from inner surface of the ventral thoracic wall and mammary glands.
  - (e) **Phrenic vein.** It collects blood from the diaphragm.
- (3) **Postcaval vein.** It collects blood from the posterior part of the body by the following veins :
- (a) **Caudal vein.** It collects blood from the tail.
  - (b) **Right and left of iliac veins.** Each iliac vein divides into right and left **femoral vein** which collects blood from the outer side of the leg and right and left **sciatic vein** which collects blood from the inner side of the leg. The two iliac veins join with the postcaval.
  - (c) **Right and left ilio-lumbar veins.** They collect blood from the lumbar region.
  - (d) **Right and left posterior mesenteric vein.** It collects blood from the large intestine.
  - (e) **Right and left genital veins.** They collect blood from gonads.
  - (f) **Right and left anterior mesenteric vein.** It collects blood from the anterior gut.
- (4) **Hepatic portal vein.** It comprises of the following veins :
- (a) **Gastric vein.** It collects blood from the stomach.
  - (b) **Anterior mesenteric.** It collects blood from the ileum.
  - (c) **Splenic.** It collects blood from the spleen.
  - (d) **Posterior mesenteric.** It collects blood from the large intestine.
  - (e) **Right and left renal veins.**

The hepatic portal vein opens into the liver.

#### 4. Rat : Arterial System

Arteries distribute blood to various parts of the body.

**Procedure.** First locate the origin of the **systemic aorta**. It originates from the left ventricle, passes dorsal to the pulmonary arch and curves round to the dorsal side of the heart and lies ventral to the vertebral column, where it extends backwards as dorsal aorta. The systemic arch distributes blood to the anterior region, while the dorsal aorta to the posterior region.

The arteries are :

- (1) **Pulmonary arteries.** They carry de-oxygenated blood to lungs. The pulmonary arteries are given by pulmonary aorta, which originates from the right ventricle and curves over on the dorsal side of the heart.
- (2) **Systemic aorta.** It gives the following branches :
  - (a) **Innominate artery.** On each side right and left innominate arteries divide into (i) Right and left **sub-clavius** and (ii) Right and left **carotid arteries**.

The **sub-clavian** artery further divides into

  - (i) *Right and left cervical artery.*
  - (ii) *Right and left auxiliary artery.*
  - (iii) *Right brachial artery and left brachial artery.*
  - (iv) *Right vertebral artery and left vertebral artery.*
  - (v) *Right radial artery and left radial artery.*
  - (vi) *Right internal mammary artery and left internal mammary artery.*
  - (b) **The left subclavian artery** arises directly from the systemic arch and supplies to shoulder girdle and arms. Its branches correspond to the right sub-clavian.
  - (c) **The right carotid artery** proceeds forwards along the trachea and near the angle of jaws it divides into the right **internal carotid** supplying to the brain, and the right **external carotid**,

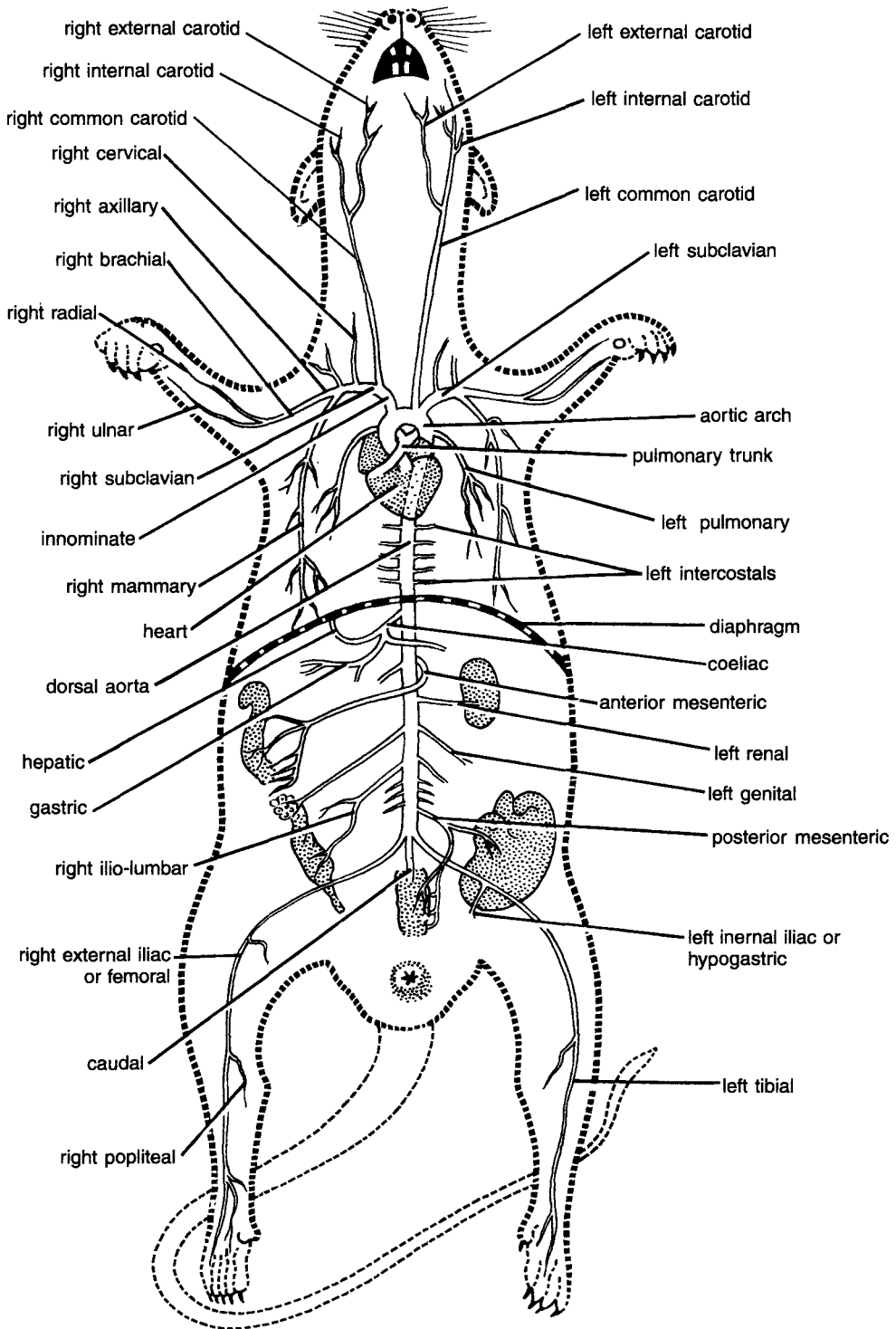

Fig. 28. Rat (*Rattus rattus*) : Arterial system.



supplying the right side of the head and face. The **left common carotid** artery directly originates from the systemic arch and divides into left internal carotid and left external carotid branches.

- (3) **Dorsal aorta.** It comprises of the following arteries :
- (a) **Right and left intercostal arteries.** They are in several pairs supplying to the wall, of the chest.
  - (b) **Right and left coeliac arteries.** It gives two branches. The **hepatic artery** supplies to the liver and the **lienogastric artery** supplies to the stomach and spleen.
  - (c) **Right and left anterior mesenteric artery.** It supplies to the intestine.
  - (d) **Right and left two gonadal arteries** supply to gonads.
  - (e) **Right and left a pair of renal arteries** supply to two kidneys.
  - (f) **Right and left posterior mesenteric artery.** It supplies to the rectum.
  - (g) **Right and left a pair of ilio-lumbar arteries.** They supply to the body wall.
  - (h) **Right and left common iliac arteries.** On each side, each common iliac originates in the pelvic region and divides into **internal iliac** and **external iliac**, which supply to the legs, and **vesicle artery** supplying to the urinary bladder.
  - (i) **Caudal artery.** The dorsal aorta continues into tail as caudal artery.

## 5. Rat : Male Urinogenital System

**Procedure.** For urinogenital system cut the sides of the pubic symphysis and remove the cut portion so as to expose the posterior part of the urinogenital system. This system comprises of urinary and genital organs.

- (1) **Urinary organs or kidneys.** You have already noted the position of kidneys which are surrounded by fat. The point of attachment of kidney with ureter is called as **hilus**. Also observe and trace the ureter up to the urinary bladder.

*Remove one kidney and observe the hilus, through which the ureter and blood vessels enter and leave. With the help of a sharp scalpel cut open the kidney longitudinally and note the following parts :*

- (2) **Genital organs.** Note the following parts :
- (a) **Testes.** A pair of testes is found in the **scrotal sacs** (right and left). The scrotal sacs are a pair of pouches in front of the anus and between the hind legs. The testes can be exposed by cutting the scrotal sacs. Each testis is elongated and ovoid body attached to the hinder end of the scrotal sacs by band of tissues called **gubernaculum**. In the very infant rat the testes lie in the abdomen close to the kidneys and just before maturity, they descend into the scrotal sacs along the inguinal canals.
  - (b) **Epididymis.** It is an irregular and in the middle **corpus epididymis** convoluted tube, found along the inner edge of testis. At anterior end it forms **caput epididymis** and at posterior end **cauda epididymis**. Cauda epididymis gives rise to **vas deferens**.
  - (c) **Vas deferens.** Each vas deferens coils round the ureter from the outside before opening into the urethra behind the **urinary bladder**.
  - (d) **Urethra.** It is the common duct for **urine** and **sperms** opening into the **penis**.
  - (e) **Penis.** It is the copulatory organ through which sperms are discharged into the female genital organ, *i.e.*, vagina of the female. The urethra opens at the tip of the penis by a slit-like opening. The tip of the penis is covered by loose skin called **prepuce**.
  - (f) **Spermatic cord.** It is an elongated cord-like structure made up by connective tissue, blood vessels and nerves, which originate from the caput epididymis and running to the body cavity through inguinal canal.

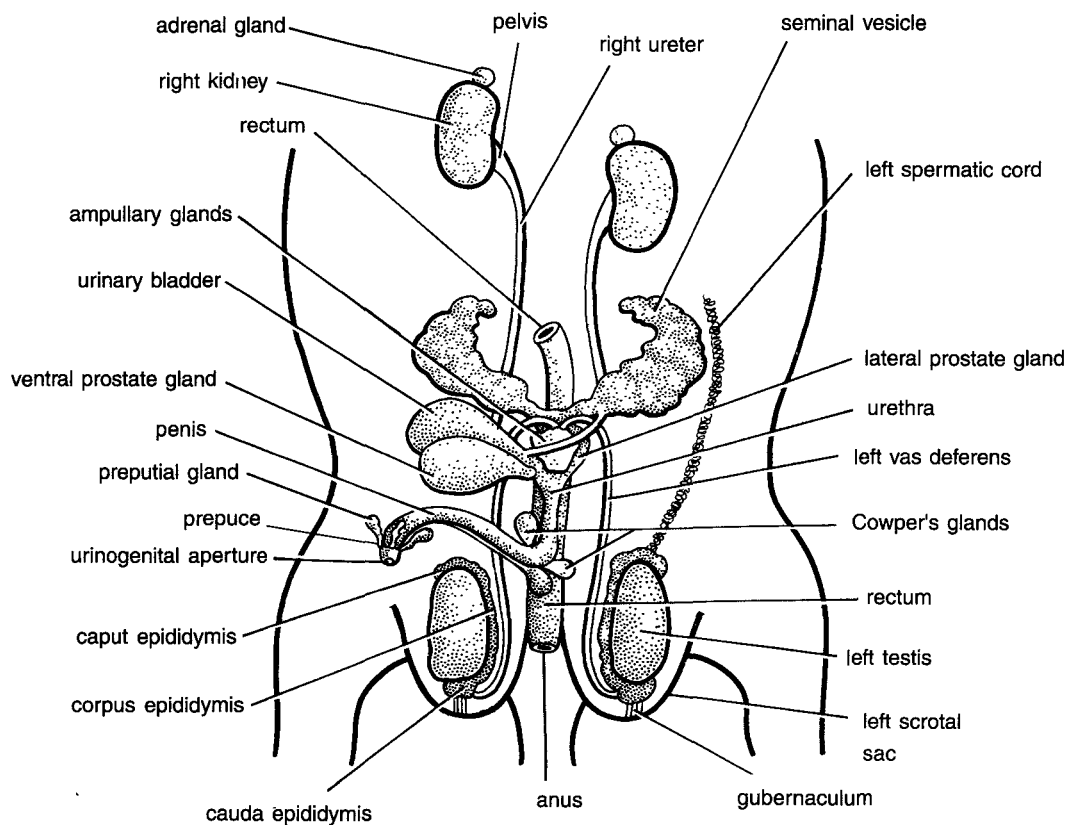

Fig. 29. Rat (*Rattus rattus*) : Male urinogenital system.

(g) **Accessory glands.** The following glands are associated with male genital system :

- (i) **Ampullar glands.** The outer end of the vas deferens near the entrance into the urethra is enlarged into the ampulla, which contains ampullar glands to secrete mucus.
- (ii) **Vesicular glands.** They are branched glands originating from the vas deferens behind the ampulla.
- (iii) **Prostate gland.** It is a large and lobulated gland, situated just behind the junction of urinary bladder with the vasa deferentia.
- (iv) **Preputial glands.** They originate from the inner fold of skin forming prepuce. They secrete odorous secretion.
- (v) **Cowper's glands.** They originate from the urethra at the base of the penis. They produce mucous secretion during sexual excitement and also protect the sperms from traces of acids found in urethra.

(h) **Seminal vesicle.** A pair of seminal vesicle which open into urethra by a common duct other structures seen are right and left kidneys, adrenal gland, right water, left ureter, pelvis, rectum and anus.

## 6. Rat : Female Urinogenital System

- (1) **Urinary system.** It consists of kidneys, ureters and urinary bladder, which are like those of male. The **urethra** is an elongated tube running towards the posterior side, opening separately at the tip of the **clitoris**.
- (2) **Reproductive system.** It has the following parts :
- (a) **Right and left ovaries.** There is a pair of small yellowish, compact structures like pea on the outer sides of the kidneys and are suspended in the body cavity by **mesovarium**. Each ovary is surrounded by **periovarian sac**.
  - (b) **Fallopian tubes.** They are coiled and convoluted tubes. Their anterior ends form **oviducal funnels**.
  - (c) **Uteri.** The posterior ends of the fallopian tubes become thickened to form uteri. Uteri open into vagina.
  - (d) **Vagina.** It is a common chamber formed by the union of the two uteri. It serves as copulatory chamber. It opens to the exterior by a slit-like opening called **vulva**.
  - (e) **Clitoris.** It is a rod-like structure, found anterior to vulva.
  - (f) **Accessory glands.** They are found only in the uterus consisting of :
    - (i) **Uterine and vestibular glands.**
    - (ii) **Bartholi's glands.** These correspond with Cowper's glands of male and are related to urinogenital passage.
    - (iii) **Preputial glands.** These are large glands opening near the tip of clitoris.

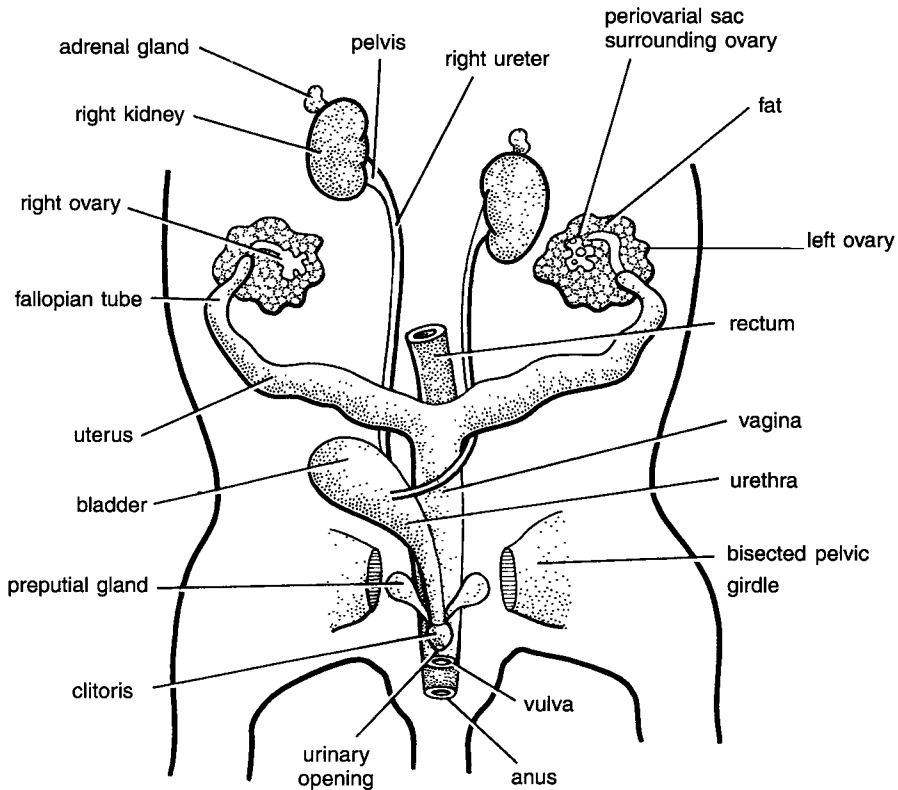

Fig. 30. Rat (*Rattus rattus*) : Female urinogenital system.

## 7. Rat : Dissection of Muscles, Blood Vessels and Nerves of Neck Region

### [I] Muscles

Remove the skin of the neck and note the following muscles :

- (1) **Digastric muscles.**
- (2) **Sternohyoid muscles.** Hyoid to manubrium.
- (3) **Omohyoid muscles.**
- (4) **Masseter muscles.**
- (5) **Sternomastoid muscles.** Manubrium to skull.
- (6) **Cleidomastoid muscles.** Clavicle to skull.
- (7) **Clavotrapezius muscles.** Clavicle to skull.
- (8) **Deltoid muscles.** Scapula to humerus.
- (9) **Pectoralis major.** From sternum to humerus.
- (10) **Pectoralis minor.** From sternum to scapula and humerus.
- (11) **Latissimus dorsi.** From thoracic vertebra to humerus.
- (12) **External oblique abdominal muscle.** From vertebra to pelvic girdle.
- (13) **Left deflected sterno-hyoid muscles.** From hyoid to manubrium.

### [II] Blood vessels and trachea

For dissecting the neck region expose the hyoid. Remove hyoid only when dissection of the neck region is completed and observe the following :

- (1) **Common carotid arteries.** They lie along the trachea. Note their divisions into the **external** and **internal carotid arteries.**
- (2) **Jugular veins.** The **external** and **internal jugular veins**, collecting blood from skull and brain, unite with **cephalic** and **subclavian** veins to form the pre-caval.
- (3) **Trachea.** It connects glottis with lungs. Anteriorly, trachea is dilated into the larynx, whose walls are supported by thyroid, arytenoid and crecoid cartilages. Note thyroid gland on either side of the larynx.

### [III] Nerves of neck region

Trace the carotid artery carefully and note the nerves lying by its side. Expose the pneumogastric nerves running on outer side.

- (1) **Vagus nerve.** The **vagus** or **pneumogastric** is a stout nerve containing a ganglionic swelling at its origin. It runs downwards from the foramen lacerum posterius and extends backwards along with carotid artery in the neck region.
- (2) **Anterior laryngeal nerve.** It is a fine delicate nerve originating from the pneumogastric nerve from the upper border of the thyroid cartilages. It innervates the mucous membrane of the larynx.
- (3) **Depressor nerve.** It is slender nerve originating from the anterior laryngeal nerve. It extends backwards along the neck dorsal to the carotid artery and it innervates heart.
- (4) **Posterior laryngeal or recurrent laryngeal.** It originates from the pneumogastric nerve or vagus nerve just above the heart and it extends forwards along the side of the trachea.
- (5) **Cervical sympathetic nerve.** It is a slender nerve running between the vagus and depressor nerves. It swells into ganglia both anteriorly into **anterior cervical ganglion** and posteriorly into the middle cervical ganglion and **posterior cervical ganglia.**
- (6) **Phrenic nerve.** It originates from the fourth cervical nerve and it extends backwards along the vertebral column. After passing through the thorax, phrenic nerve gives several small branches in the diaphragm.

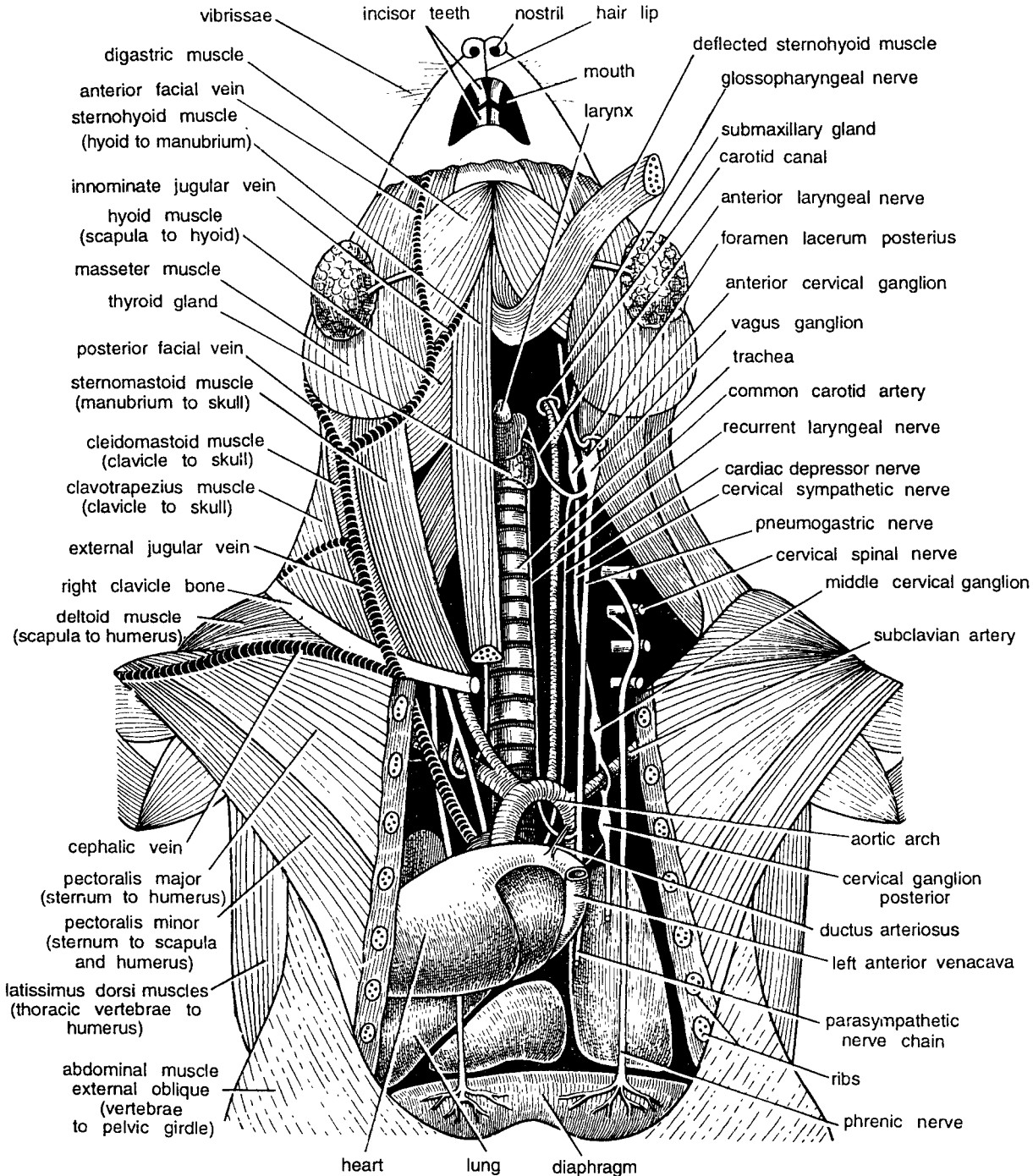

Fig. 31. Rat (*Rattus rattus*) : Dissections of muscles, blood vessels and nerves of neck region.

#### [IV] Other structures

Other structures seen are vibrissae, incisor teeth, nostril, hairtip, mouth, larynx, glossopharyngeal nerve, sub-maxillary glands, carotid canal, vagus ganglion, trachea, left anterior venacava, parasympathetic nerve chain, ribs, diaphragm heart and sub-clavian artery.

# Experimental Biochemistry and Physiology

# 12

Both Biochemistry and physiology are closely associated with chemical constitution and functions of the biological organisms and hence their practical experiments have been included in this chapter. But the practical experiments associated with biochemistry and physiology have been given separately.

## EXPERIMENTS ON BIOCHEMISTRY

The practical experiments in biochemistry consists of the following :

- (1) Colour and precipitation reactions for identification of food stuffs (biochemical test) Tests on  
1. Carbohydrates, 2. Proteins, 3. Fats, 4. Enzymes.
- (2) Identification of aminoacids, amines, peptides and carbohydrates by paper chromatography.

## COLOUR AND PRECIPITATION REACTIONS OF FOODSTUFFS AND ENZYMES

The major content of our food consists of **carbohydrates, protein** and **fat**. Carbohydrates include wheat bread, potato and sugar. Protein food consists of egg, mutton, milk and green leafy vegetables. For digestion of above food various enzymes are needed. The chemical nature of above food items can be identified by performing various tests or experiments regarding their colour and precipitation reactions. The above food stuffs give different colours and form precipitate when treated with different chemicals.

The following laboratory reagents and glass apparatus are needed for performing various experiments for their identification.

### Some Important Chemicals

- |  |                                    |   |
|--|------------------------------------|---|
| 1. Absolute alcohol                                | 23. Fructose 0.5%                  | 45. Oleic acid                            |
| 2. Acetic acid glacial                             | 24. Glucose 0.2%                   | 46. Olive oil                             |
| 3. Alcoholic caustic soda                          | 25. Glucose 0.5%                   | 47. Peptone                               |
| 4. Ammonium sulphate                               | 26. Glucose 1%                     | 48. Phenolphthalein                       |
| 5. Barfoed's reagent                               | 27. Glucose 2%                     | 49. Phenylhydrazine hydrochloride         |
| 6. Barium chloride ( $\text{BaCl}_2$ )             | 28. Glycerol                       | 50. Picric acid                           |
| 7. Benedict's solution                             | 29. Glyoxalic acid reagent         | 51. Potassium dihydrogen phosphate        |
| 8. Bismuth sub-nitrate                             | 30. Iodine solution                | 52. Potassium ferricyanide soln. 1%       |
| 9. Caustic soda                                    | 31. Lactose 2%                     | 53. Potassium ferrocyanide solution       |
| 10. Chloroform                                     | 32. Lead acetate                   | 54. Potassium hydrogen sulphate           |
| 11. Chlorophenol red                               | 33. Magnesium sulphate             | 55. Seliwanoff's reagent                  |
| 12. Conc. HCl (Hydrochloric acid)                  | 34. Maltose 2%                     | 56. Silver nitrate ( $\text{AgNO}_3$ )    |
| 13. Conc. $\text{H}_2\text{SO}_4$ (Sulphuric acid) | 35. Mercuric nitrate               | 57. Sodium acetate                        |
| 14. Copper sulphate 0.5%                           | 36. Mercuric chloride saturated    | 58. Sodium hydrogen sulphate              |
| 15. Copper sulphate 1.0%                           | 37. Mercuric sulphate              | 59. Sodium chloride                       |
| 16. Egg white 5%                                   | 38. Methylene blue 1%              | 60. Sodium hypobromide ( $\text{NaOBr}$ ) |
| 17. Esbach's reagent                               | 39. Na-K tartarate (Rochelle salt) | 61. Sodium nitrite ( $\text{NaNO}_2$ )    |
| 18. Ether  | 40. NaOH 40%                       | 62. Sucrose 2%                            |
| 19. Ethyl acetate                                  | 41. NaOH saturated                 | 63. Sulphosalicylic acid 20%              |
| 20. Fehling's solution                             | 42. $\alpha$ -naphthol 1%          | 64. Tannic acid                           |
| 21. Ferric chloride 0.5-1%                         | 43. Ninhydrin 1%                   | 65. Thymol alcoholic 5%                   |
| 22. Fructose 0.2%                                  | 44. Nylander's reagent             | 66. Toluene                               |

### Some Important Laboratory Reagents

- (1) **Alpha naphthol** : Dissolve 1 gm of  $\alpha$ -naphthol in 95% alcohol.
- (2) **Ammonium molybdate** : Dissolve 75 gm ammonium molybdate crystals in 300 cc of strong ammonia. Add this solution in 900 cc of conc.  $\text{HNO}_3$  and then add 400 cc of water, cool and add more 1600 cc of water. Filter.
- (3) **Barfoed's reagent** : Dissolve 13.3 gm of neutral copper acetate crystals in 200 cc of distilled water. Filter and add 1.8 cc of glacial acetic acid.
- (4) **Barium chloride** : 10% solution in water.
- (5) **Basic lead acetate** : Dissolve 180 gm of lead acetate in 700 cc of water.
- (6) **Benedict's reagent** : (Qualitative) : Prepare solutions A and B. (i) Dissolve by heating 173 gm of sodium citrate and 100 gm of anhydrous sodium carbonate in about 800 cc of water. (ii) Dissolve 17.3 gm of copper sulphate crystals in 100 cc of water. Cool the solutions. Add B to A with constant stirring in 100 cc titration flask and dilute with distilled water upto the mark.
- (7) **Chromic acid** (for cleaning glass apparatus) : Dissolve 60 gm of potassium dichromate in 300 cc of water in a glass trough and then add 460 cc of conc.  $\text{H}_2\text{SO}_4$ . The mixture becomes very hot. Cool under running water. The liquid is utilized to clean the glass apparatus.
- (8) **Esbach's reagent** : Dissolve 1 gm of picric acid and 2 gm of citric acid in 100 cc titration flask. Dilute with water upto the mark.
- (9) **Fehling's solution** : (i) Dissolve 7.93 gm of copper sulphate crystals in 100 cc of distilled water, (ii) Dissolve 250 gm of KOH and 320 gm of Na-K-tartarate in 1000 cc of distilled water.
- (10) **Nylander's reagent** : Dissolve 2 gm of bismuth sub-nitrate and 4 gm of Na-K-tartarate in 100 cc of 10% KOH. Cool and filter.

## Glass Apparatus

Test tubes, funnels, beakers, pipettes, measuring cylinders, glass-stoppered bottles, spirit lamps, titration flasks, conical flasks, reagent bottles. Besides these, filter papers, cotton, test tube holders, test tube stands are also required.

**Note :** All the glass apparatus must be chemically and physiologically cleaned. For example, a test tube should be washed first with vim and then it should be dried. After removing moisture, rinse the tube with chromic acid solution. Then wash the test tube 9 times with tap water and 3 times with distilled water. Now, the test tube is cleaned properly and is ready for experiments.

## BIOCHEMICAL TESTS

Some important test on Carbohydrates, Proteins, Fats and Enzymes have been described here.

### 1. Test on Carbohydrates

Carbohydrates are abundantly found in the plants and as glycogen in the animals. In animals they are found in free stored state as glycogen or in combination with proteins as glycoprotein. The name carbohydrate is given because they are composed of **carbon, hydrogen and oxygen atoms**.  $H_2$  and  $O_2$  are found in the same proportions as in water ( $H_2O$ ). Chemically carbohydrates are aldehyde and ketone derivatives of alcohols (aldoses and ketoses). In general, carbohydrates are white solids, sparingly soluble in organic liquids, except for certain polysaccharides, soluble in water. Many carbohydrates are of low molecular weight and having sweet taste. Carbohydrates are classified into 3 groups :

- (1) **Monosaccharides** or simple sugars ( $C_6H_{12}O_6$ ),
- (2) **Di- and tri-saccharides** or compound sugars,
- (3) **Polysaccharides**.

#### A. Monosaccharides

Monosaccharides or simple sugars occur abundantly in nature in the form of glucose and fructose. They occur in white crystalline form easily soluble in water and hot alcohol and practically insoluble in organic solvents like absolute alcohol, ether and acetone, etc. They are optically active and being aldehydes and ketones show common reactions.

In alkaline solution all the monosaccharides and many disaccharides behave as reducing agents and are easily oxidised by various reagents as silver and copper, etc. Most of the quantitative analysis for sugars depend upon the measurement of the reduction of  $Cu^{++}$  to  $Cu^+$  by alkaline sugar solutions.

#### B. Experiments with Glucose and Fructose

Make 0.2% and 2% solutions of the Dextrose-D or Fructose and perform the following experiments in order to identify the reducing action of glucose and fructose :

##### **Experiment (1) Reduction of methylene blue.**

**Procedure :** In a test tube take 3 cc of distilled water, then add a drop of methylene blue (1%). The water becomes blue coloured. Add 0.5 cc of 40% NaOH. Boil the solution. Colour is not discharged, blue colour remains. Add 1 cc of 0.2% glucose or fructose solution and boil.

**Result :** The solution is **decolourised** due to formation of leuco-methylene blue, the reduction product of methylene blue.



**Experiment (2) Reduction of alkaline ferricyanide.**

**Procedure :** In a test tube take 3 cc of 1% potassium ferricyanide solution and add 1 cc of 40% NaOH solution. Boil the solution. Add 0.2% glucose solution to the hot solution drop by drop and keep on boiling.

**Result :** The yellow colour of the ferricyanide begins to fade and finally **decolourise**.

**Experiment (3) Tommer's test. Reduction of alkaline copper sulphate.**

**Procedure :** In a test tube take 2 cc of 0.5% copper sulphate solution, then add 2 cc of 0.2% glucose solution and mix. Add 2 cc of 40% NaOH solution. A clear blue solution is obtained. Glucose acts as a solvent for cupric hydroxide  $\text{Cu}(\text{OH})_2$  and prevents its precipitation. Boil.

**Result :** **Yellow or red precipitate** of  $\text{Cu}_2\text{O}$  is formed due to the reduction of  $\text{CuSO}_4$ .

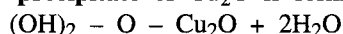
**Experiment (4) Fehling's test.**

**Procedure :** Take 5 cc of Fehling's solution and boil. There is no change of colour on the formation of precipitate, (in case of colour change and precipitate formation reject the solution). Add 1 cc of glucose solution and boil again.

**Result :** Colour changes with the formation of **yellow or brick-red precipitate of  $\text{Cu}_2\text{O}$** .

**Experiment (5) Benedict's test.**

**Procedure :** In a test tube 5 cc of Benedict's reagent, then add 0.5 cc of glucose solution and heat to boiling. Boil for 2 minutes. Cool the solution under tap water.

**Result :** **Green, yellow or red precipitate** of  $\text{Cu}_2\text{O}$  is formed.

**Experiment (6) Picric acid test.**

**Procedure :** In a test tube take 3 cc of 2% glucose solution, then add 1 cc of picric acid saturated solution and then add 1 cc of 40% NaOH.

**Result :** Picric acid is reduced to picramic acid with the formation of **red colour**.

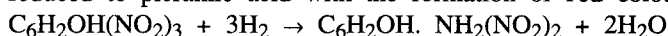
**Experiment (7) Nylander's test.**

**Procedure :** In a test tube take 5 cc of 2% glucose solution, add 0.5 cc of Nylander's reagent and heat to boiling and keep on boiling for 2 minutes.

**Result :** The solution becomes **dark black**, as bismuth sub-nitrate is reduced to bismuth.

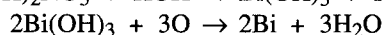
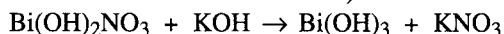
**Experiment (8) Rapid furfural test.**

**Procedure :** Take 1 cc of 2% fructose solution, add 6 drops of  $\alpha$ -naphthol, then add 5 cc of conc. HCl in a test tube and boil.

**Result :** As the mixture begins to boil, **deep purple colour** appears.

**C. Disaccharides**

Disaccharides include lactose, maltose and sucrose.

(1) **Lactose :** It is found in milk and also in the urine of women during pregnancy and lactation.

(2) **Maltose :** It is the final product of starch hydrolysis.

(3) **Sucrose :** Abundant in plants as a reserve food material.

Lactose and maltose are reducing sugars and give positive Tommer's Fehling's, Benedict's and Barfoed's tests. Sucrose gives positive Rapid Furfural and Seliwanoff's tests. Lactose and maltose form osazones with characteristic crystalline forms and they can be classified by microscopic examination. Lactosazone forms mushroom-shaped crystals, glucosazone forms needle-shaped crystals, while maltosazone forms flower-shaped crystals. Sucrose does not form osazone. For the osazone formation, prepare 0.5% glucose and fructose solutions, 2% lactose, 2% maltose and 2% sucrose. In a test tube take 5 cc of sugar solution and add

10 drops of glacial acetic acid, then add a knife point of phenylhydrazine hydrochloride, then add twice the amount of sodium acetate crystals, give a little heat to the solution to dissolve the solids. Filter the solution and keep the filtrate in boiling water bath for 20 minutes, then remove and examine.

## 2. Test on Proteins

Proteins, found in animals and plants, are important building blocks formed by amino acids, condensed together by peptide linkage. All proteins contain carbon, hydrogen, oxygen, nitrogen and with a few exceptions sulphur also. The alimentary composition of proteins consists of approximately C = 45-55%, H = 6-8%, O = 19-25% and N = 14-20%. Proteins have high molecular weight. They contain free amino and carboxyl groups and so they can combine with bases and acids depending upon the pH of the medium. On hydrolysis, proteins break into peptones, proteoses, peptides and amino acids. Chemical behaviour of the proteins is due to the amino acids in the protein molecules.

For experiments fresh 5% solution of egg white is prepared. Egg white is filtered through cotton. Dissolve 5 cc of egg white into 95 cc of distilled water for 5% egg white solution. Proteins show both precipitation and colour reactions.

### A. Precipitation of Proteins with Heavy Metals

#### *Experiment (1) Mercuric chloride test.*

**Procedure :** In a test tube take 3 cc of 5% egg white solution, then add mercuric chloride drop by drop.

**Result :** White turbidity is produced first which becomes thick and granular. The heavy metal salts precipitate protein solutions. This precipitate is generally soluble in excess of the salt solutions.

#### *Experiment (2) Ferric chloride test.*

**Procedure :** Take 3 cc of 5% egg white solution and add 0.5% ferric chloride solution drop by drop.

**Result :** On addition of first drop, turbidity appears and it increases on addition of subsequent drops. If  $\text{FeCl}_3$  is added in excess, the turbidity disappears.

### B. Precipitation of Proteins by Alkaloid Reagents

#### *Experiment (3) Sulphosalicylic acid test.*

**Procedure :** In a test tube take 3 cc of 5% egg white solution and add 20% sulphosalicylic acid.

**Result :** White precipitate is obtained.

#### *Experiment (4) Esbach's test.*

**Procedure :** Take 3 cc of 5% egg white solution in a test tube and add a little Esbach's reagent.

**Result :** Yellowish precipitate is formed. By this method the quantity of albumen in urine is also estimated.

#### *Experiment (5) Tannic acid test.*

**Procedure :** In a test tube, take 3 cc of 5% egg white solution and then add 5 drops of freshly-prepared tannic acid solution.

**Result :** Brownish and non-granular precipitate is formed.

#### *Experiment (6) Hellers' test.*

**Procedure :** Take 3 cc of concentrated  $\text{HNO}_3$  in a test tube and then add very carefully 3 cc of 5% egg white solution by means of a pipette in such a manner that it forms upper layer. Mix gradually by rotating between palms.

**Result :** A white ring is formed at the junction of the two solutions.

**Experiment (7) Acetic acid-potassium ferrocyanide test.**

**Procedure :** In a test tube take 3 cc of 5% egg white solution, then add 3 drops of glacial acetic acid, and 3 drops of potassium ferrocyanide solution.

**Result :** White precipitate is obtained. The precipitation is due to the proteoses, which dissolves on boiling and reappears on cooling.

**C. Colour Reactions of Proteins**

Proteins show colour reactions which are due to the presence of constituent radicals in the complex protein molecule. Since different proteins contain different groups, all proteins do not give positive reaction with all colour experiments. Sometimes, non-proteins or prosthetic groups also respond to certain colour reactions and hence several tests must be done before drawing any conclusion. For colour reaction experiments prepare 5% egg white solution.

**Experiment (8) Biuret reaction.**

**Procedure :** Take 3 cc of 5% protein solution in a test tube, add 1 cc of 40% NaOH solution to make it strongly alkaline, and then add 2 drops of 1% copper sulphate solution.

**Result :** Violet or pink colour appears. This reaction is due to the peptide linkage and so it is positive with all proteins.

**Experiment (9) Ring biuret test.**

**Procedure :** Take 3 cc of 5% or even more dilute egg white solution in a test tube, add 1 cc of 40% NaOH, then add by means of a pipette 1 cc of 1% copper sulphate over the surface of the liquid very gently so that the 2 fluids do not mix. Rotate gently.

**Result :** A pink or violet ring is formed at the junction of the two fluids. Proteoses and peptones give rose colour. Gelatin gives bluish pink or violet colour.

**Experiment (10) Xanthoproteic reaction for tyrosine, phenylalanine and tryptophane.**

**Procedure :** Take 3 cc of 5% egg white solution in a test tube, add 1 cc of conc.  $\text{HNO}_3$  and boil. First white precipitate is formed which changes to yellow. The liquid also becomes yellow. Cool the test tube and add excess of 40% NaOH or ammonia to make alkaline.

**Result :** The yellow colour changes to orange. The proteoses and peptones do not form precipitate with  $\text{HNO}_3$  but their solution turns yellow to orange in the presence of alkali. The precipitate is due to the formation of metaproteins insoluble in  $\text{HNO}_3$  (nitric acid). The yellow colour is due to nitro-compounds from the protein molecule containing benzene ring. When made alkaline, the nitro-compounds ionize freely and produce deep yellow or orange colour.

**Experiment (11) Millon's test for tyrosine.**

**Procedure :** In a test tube take 3 cc of 3% egg solution, and 2 cc of mercuric sulphate reagent by pipette and boil cautiously for a minute. A yellowish precipitate generally formed. Cool the tube and add 2 drops of 1%  $\text{NaNO}_2$  (sodium nitrite). Heat again.

**Result :** The solution and the precipitate become red showing the presence of tyrosine.

**Experiment (12) Aldehyde test for tryptophane.**

**Procedure :** In a test tube take 3 cc of protein solution (5% egg white), then add one drop of 0.2% of 40% formalin, then add 0.5 cc of mercuric sulphate reagent. Shake well and then add 2.0 cc of conc.  $\text{H}_2\text{SO}_4$ . Shake.

**Result :** Violet or purple colour develops. Sometimes, a little heat is required for the colour to appear.

**Experiment (13) Glyoxalic acid test for tryptophane.**

**Procedure :** In a test tube take 3 cc of 5% egg white solution for protein and add 3 cc of glyoxalic reagent. Now add this solution very carefully to another test tube containing 5 cc of conc.  $\text{H}_2\text{SO}_4$  in such a manner that the two fluids do not mix. Rotate the tube gently.

**Result :** Purplish violet colour develops at the junction of the fluids. The purple or violet colour is due to the presence of tryptophane, which forms condensation product with the aldehyde.

**Experiment (14) Arginine test for arginine.**

**Procedure :** In a test tube take 3 cc of 5% egg white protein solution, then add 2 drops of 1%  $\alpha$ -naphthol solution, then add 1 cc of 40% NaOH solution, and then add 2 drops of sodium hypobromide (NaOBr).

**Result :** Bright colour is obtained. This reaction is specifically meant for arginine which is present in all proteins.

**Experiment (15) Sulphur test for cystine and cysteine.**

**Procedure :** In a test tube take 3 cc of protein solution (5% egg white), then add 5 drops of lead acetate which causes precipitation. Now add 40% NaOH drop by drop till the precipitate dissolves. Boil.

**Result :** Black or brown precipitate is formed, which shows the presence of cystine or cysteine group.

**Experiment (16) Molisch's test for carbohydrate group attached to protein molecule.**

**Procedure :** In a test tube take 3 cc of 5% egg white protein solution, then add 2 drops of 5% alcoholic thymol; now incline the tube and gently add 3 cc of conc.  $H_2SO_4$  (the acid should go by the side of the tube wall) in such a way that the fluids do not mix. Rotate the tube gently.

**Result :** Purple-violet ring, at the junction of the fluids, is formed which shows the presence of carbohydrate group attached to the protein molecule.

**Experiment (17) Ninhydrin test.**

**Procedure :** Take 1 cc of 5% egg white protein solution and add 4 drops of 0.1% ninhydrin solution and boil for one minute. Cool the test tube.

**Result :** Blue colour develops. The test gives positive results by all amino acids and their derivatives except proline and hydroxyproline.

### 3. Test on Fats and Oils

Fats and oils are found abundantly in plants and animals forming distinct foodstuff. Fats have double caloric value than the carbohydrates. Fats have greasy feel with low melting point. They are soluble in organic solvents like ether, chloroform and alcohol and insoluble in water. Fats are hydrolysed by boiling acids and alkalines. Simple fat is glycerol which forms esters with 3 molecules of the same different acids and the most common acids are :

- (1)  $CH_3(CH_2)_4.COOH$  — palmitic acid
- (2)  $CH_3(CH_2)_{16}.COOH$  — stearic acid
- (3)  $CH_3(CH_2)_7.CH = CH(CH_2)_7.COOH$  — oleic acid.

For experiments with fats, olive oil is quite suitable.

**Experiment (1) Solubility test.**

**Procedure :** In separate test tubes marked A, B, C and D, take 0.5 cc of water in test tube A, 5 cc of ether in test tube B, 5 cc of chloroform in test tube C, and 5 cc of alcohol in test tube D. Add 3 drops of oil, preferably olive oil, in each test tube drop by drop.

**Result :** Test tube A = oil is not miscible and it floats.

Test tube B = oil is miscible.

Test tube C = oil is miscible.

Test tube D = oil sinks to bottom; on heating oil dissolves.

**Experiment (2) Acrolin test.**

**Procedure :** In a dry test tube take 0.5 cc of olive oil, then add knife point of sodium or potassium hydrogen sulphate and mix thoroughly by a glass rod and heat.

**Result :** Observe irritating odour of Acrolin. The glycerol present gives Acrolin on dehydration.

**Experiment (3) Emulsification of fats.**

**Procedure :** In a test tube take 3 cc of neutral olive oil, then add 2 drops of oleic acid, mix by shaking to form rancid oil. Now add 2 drops of this rancid oil to another test tube already containing 3 cc of dilute caustic soda.

**Result :** The acid dissolves in alkali forming a soap, which entangles oil by diffusion to form emulsion.

**Experiment (4) Salting out.**

**Procedure :** Take 10 drops of olive oil in a test tube, add 2 cc of alcoholic caustic soda, boil carefully. Soap solution is obtained. Divide this solution equally in 3 separate test tubes marked A, B and C. To test tube A add 3 cc of conc. HCl or H<sub>2</sub>SO<sub>4</sub>, to B add sodium chloride powder and to C add 2% calcium solution. Observe.

**Result :** Test tube A = small oil globules separate and float on the surface.

Test tube B = white precipitate separates and floats on the surface.

Test tube C = white precipitate of calcium soap is formed.

## 4. Test on Enzymes

**Experiment (1) To demonstrate action of salivary enzyme amylase (ptyalin).**

**Principle :** Enzyme amylase is found in saliva, which is secreted by salivary glands in mouth palate.

Amylase partially hydrolysed (breaks) starch or glycogen into glucose and maltose. Salivary amylase acts at a temperature of 37°C and at a pH of 6.6 (acidic). When iodine solution is mixed with starch, blue colour is obtained. When starch is first hydrolysed with amylase and then mixed with iodine solution, blue colour is not obtained because starch has been broken into glucose and maltose.

**Requirements :** Beakers (100 cc), pipettes, test tubes, glass-stoppered bottles, plain or cavity slides, staining tubes, cavity blocks (small), toluene, starch paste, 0.02N iodine solution, incubator set at 37°C.

**Procedure :** (1) Clean all glass apparatuses first with vim. Dry them and then rinse with potassium dichromate sulphuric acid solution. Wash glass apparatuses 9 times with tap water and 3 times with distilled water. In case chromic acid solution is not available, wash them with vim, tap water and then with distilled water. Let all the apparatuses become dry. Keep them inverted over blotting paper for 24 hours.

- (2) Prepare 0.02 N iodine solution in a glass stoppered bottle.
- (3) Prepare 1% starch solution (1 gm of starch powder + 100 cc of distilled water) in glass stoppered bottle.
- (4) For collecting own saliva, rinse your mouth with warm water quickly. Then take 20-25 cc of warm water in mouth, rotate water with tongue for 2-3 minutes and collect the saliva solution in a beaker. This contains salivary enzyme **amylase**.
- (5) In another beaker mix 5 cc of 1% starch solution and 5 cc of saliva solution. Incubate the beaker in an oven set at 37°C for one hour.
- (6) Take two cavity blocks or staining tubes and mark them A and B respectively with glass marking pencil. In each cavity block or a staining tube, add 2 drops of iodine solution. In cavity block A add a drop of starch-saliva mixed solution with a pipette. With another pipette add a drop of starch solution only in cavity block B.

**Result :** In cavity block B, solution becomes blue while in cavity block A it remains colourless as starch has been hydrolysed into glucose and maltose demonstrating activity of enzyme amylase.

**Experiment (2) To demonstrate action of pepsin on protein.**

**Principle :** Pepsin is a proteolytic enzyme secreted by gastric glands in the stomach. It is secreted in inactive form, called **pepsinogen**, which becomes active in the presence of HCl and then is called **pepsin**. **Pepsin hydrolyses proteins into peptones proteoses**. The enzyme acts at a temperature of 37°C and with a pH highly acidic (1.5 to 2.2). Both pepsin and pepsinogen have been prepared in a crystalline form. To demonstrate pepsin, **casein** protein is used. Pepsin acts on casein forming precipitate.

**Requirements :** Glass apparatuses as mentioned in case of amylase. Clean them as mentioned earlier. In addition **casein**, thymol, acetic acid, glycerol, HCl and sodium acetate. A hand centrifuge or high speed electrically operated centrifuge, centrifuge glass tubes and an incubator set at 37°C.

- Procedure :** (1) Prepare 2% casein solution by dissolving vitamin free 2.0 gm of casein powder in 5 ml of 0.1 N NaOH (sodium hydroxide solution) in a 100 cc beaker. Add 50 ml of 60°C heated distilled water to the solution.
- (2) In another beaker mix 5 ml of 1N HCl and 45 ml of distilled water.
- (3) In a third beaker mix the above solution. Mixed solution is clear casein solution having pH of 1.5.
- (4) Prepare extract of a portion of stomach wall. Dissect a frog. Take out stomach. Cut the stomach into very small pieces. Keep the stomach in a mortar containing 50% glycerol. Ground the stomach with pistol making a paste or homogenise stomach tissue in a homogenizer. This homogenized tissue is called as **extract**.
- (5) Centrifuge the above extract in a centrifuge at minutes. Take out the extract and filter. Filtrate is stored with toluene at room temperature.
- (6) Prepare 10% sodium acetate solution (10 gm of sodium acetate + 100 cc of distilled water).
- (7) Take two cavity blocks or staining tubes and mark them A and B. In A add 5 drops of casein solution and then 5 drops of stomach extract solution. In B add 5 drops of casein solution and 5 drops of distilled water. **Incubate** both cavity blocks in an incubator set at 37°C for 8 to 10 hours.
- (8) After 10 hours take out both cavity blocks and in each add 1 drop of 10% sodium acetate solution and observe.

**Result :** In cavity block B **precipitate** is formed while in cavity block A no precipitate is formed because casein has been hydrolysed by stomach extract containing pepsin demonstrating thereby action of pepsin on proteins.

**Experiment (3) To demonstrate action of trypsin on protein.**

**Principle :** Like pepsin, trypsin is also a proteolytic enzyme secreted from the intestine and pancreas. In pancreas, it is secreted into inactive **trypsinogen** and is converted into active **trypsin** in bile in alkaline medium (pH 8.0). It acts on proteoses and peptones, converting them into polypeptides and dipeptides. Acetic acid form precipitate with protein (casein).

**Requirements :** Same as in case of amylase.

- Procedure :** (1) Prepare extract solution of pancreas or intestine as in case of stomach.
- (2) Prepare 2% casein solution as mentioned for experiment No. 2.
- (3) Take two cavity blocks or staining tubes and mark them A and B.
- (4) In cavity block A add 5 drops of casein solution and 5 drops of extract solution. In block B add 5 drops of casein solution and 5 drops of distilled water. Incubate these cavity blocks in incubator set at 37°C. In each cavity block also add 5 drops of 7.8 pH buffer before keeping in incubator. Incubate for 4 to 6 hours.
- (5) Take out cavity blocks and add 1% acetic acid solution to each and observe.

**Result :** Precipitate appears in cavity block B while no precipitate appears in A because trypsin has hydrolysed proteins demonstrating action of trypsin on proteins.

**Experiment (4) To demonstrate presence of albumin, sugar and ketone bodies in the urine (clinical tests).**

**Requirements :** Beakers 100 cc, test tubes, acetic acid, sulphosalicyclic acid, soya bean flour, ammonium sulphate, alcoholic phenolphthalein, and sodium nitroprusside.

**Procedure :** (a) **For albumin (proteins).**

- (1) Collect urine sample in a beaker.
- (2) Take 20 cc of urine in a test tube. Boil the sample in such a way that only upper layer is heated. Appearance of turbidity shows presence of albumen. Add 3 to 5 drops of 5% acetic acid in the test tube.

**Result :** Appearance of turbidity confirms presence of albumen.

(b) **For sugar :** Perform the tests as mentioned for testing food stuffs with colour reactions.

(c) **For ketone bodies :**

- (1) Take urine sample in a test tube.
- (2) Saturate the sample with ammonium sulphate.
- (3) Add few drops of ammonia solution.
- (4) Add few crystals of sodium nitroprusside and shake the sample thoroughly.

**Result :** Appearance of reddish purple colour shows presence of ketone bodies.

## 5. General Experiments

**Experiment (1) :** To study the given substance.

Experiments	Observation	Inference
1. Substance + Water → Shake	Substance completely dissolves.	Carbohydrate.
2. 3 cc H <sub>2</sub> O + Methylene blue + 0.5 cc of NaOH. Boil → Add 1 cc of glucose soln.	The colour disappears.	Sample is carbohydrate.
3. 3 cc Pot. ferricyanide soln + 1 cc NaOH → Boil.	Blue solution appears and becomes brick-red on boiling.	Sample is carbohydrate.
4. 2 cc CuSO <sub>4</sub> + soln. + 2 cc An OH. → Boil.	Blue solution appears and becomes brick-red on boiling.	Sample is carbohydrate.
5. 5 cc Fehling's soln. + 1 cc soln. → Boil.	Brick red ppt. of Cu <sub>2</sub> O appears.	Sample is carbohydrate.
6. 5 cc Benedict's qualitative soln. + soln. → Boil and cool under tap.	Red ppt. of Cu <sub>2</sub> O appears.	Sample is carbohydrate.
7. 3 cc soln. + 1 cc Sat. Picric acid soln. + 1 cc NaOH	Red colour develops.	Sample is carbohydrate.

**Result :** The given carbohydrate was identified.

**Experiment (2) To identify the given samples A, B and C of carbohydrate.**

Experiments	Observations (Write positive or negative)	Inference
<b>Sample (A)</b>		
1. Sample + H <sub>2</sub> O → Shake.	Sample easily dissolves.	Sample may be sugar.
2. Methylene blue test.	Positive	Sample is carbohydrate.
3. Pot. Ferricyanide test.	Positive	Sample is carbohydrate.
4. Tommer's test.	Positive	Sample is carbohydrate.
5. Benedict's test.	Positive	Sample is carbohydrate.
6. Fehling's test.	Positive	Sample is carbohydrate.
7. Picric acid test.	Positive	Sample is carbohydrate.
8. Nylander's test.	Positive	Sample is carbohydrate.
9. Rapid's Furfural test.	Positive	Sample is carbohydrate.
10. Soln. + 3cc lead acetate → boil + NH <sub>2</sub> OH → boil.	Pink colour is obtained.	Sample is glucose.

Sample (B)		Sample (C)	
1. Methylene blue test.	Positive	1. Methylene blue test.	Positive
2. Pot. ferricyanide test.	Positive	2. Pot. ferricyanide test.	Positive
3. Tommer's test.	Positive	2. Tommer's test.	Positive
4. Benedict's test.	Positive	4. Benedict's test.	Positive
5. Fehling's test	Positive	5. Fehling's test.	Positive
6. Picric acid test.	Positive	6. Nylander's test.	Positive
7. Nylander's test	Positive	7. Barfoed's test.	Positive
8. Seliwanoff's test	Negative	8. Furfural test.	Negative
9. Soln. + 3 cc lead acetate → boil + NH <sub>4</sub> OH → boil.	A red colour obtained.	9. Soln. + H <sub>2</sub> SO <sub>4</sub> + HNO <sub>3</sub> → heat + 70° warm water → heat	A sandy ppt. appears.

**Result :** Sample A. Glucose. Sample B. Maltose. Sample C. Lactose.

**Experiment (3) :** To identify the given samples.

Experiments	Observations	Inference
1. Biuret test.	Positive	Sample is protein.
2. Xanthoproteic test.	Positive	Sample is protein.
3. Millon's test.	Positive	Sample is protein.
4. Aldehyde test.	Positive	Sample is protein.
5. Arginine test.	Positive	Sample is protein.
6. Molsch's test	Positive	Sample is protein.

**Result :** The given sample is protein.

**Experiment (4) To identify the given samples.**

Experiments	Observations	Inference
1. Sample + NaHSO <sub>4</sub> → heat.	Irritating smell.	Sample is oil.
2. Sample + Oleic acid → shake + NaOH.	Soap is formed.	Sample is oil.
3. Sample + Alcoholic KOH → boil and divide it into 3 parts in test tubes.		
First T.T. + conc. HCl.	Oil separates and floats on surface.	Sample is oil.
Second T.T. + NaCl.		Sample is oil.
Third T.T. + CaCl <sub>2</sub>	white ppt. white ppt.	Sample is oil.

**Result :** The given sample is oil.

## IDENTIFICATION OF AMINOACIDS, AMINES, PEPTIDES AND CARBOHYDRATES BY PAPER CHROMATOGRAPHY

In paper chromatography a stationary liquid phase is supported by paper sheet having cellulose fibers. The mobile phase moves along the paper sheet by capillary action or gravity feed. The mixture to be separated is applied as a spot on chromatogram. The distance travelled by specific substance under specific set of conditions like temperature, solvent system, direction of flow and type of paper is characteristic and may be used to identify it. The relation of the distance travelled by a compound to that of the solvent front is called R<sub>F</sub> value. According to Morris and Morris (1964), it is defined as the "ratio of the linear rate of movement of the solute zone to the linear rate of movement of the solvent." R<sub>F</sub> value may be calculated by the following formula :

(Z-21)



$$R_F = \frac{\text{Distance from origin travelled by compound}}{\text{Distance of solvent from origin}}$$

In some cases, where a mixture is suspected to contain compounds having similar or identical  $R_F$  values, the resolution or chromatogram can be improved by developing in two directions with two different solvent systems and it is called as **two-dimensional chromatography**. In this case, mixture is spotted at one corner of the paper or plate and is developed in one direction using a given solvent. After chromatogram is dried it is rotated  $90^\circ$  and developed again in a second direction in a different solvent system.

### Choice of filter paper

Generally Whatman No. 1 or Schleicher and Schnell or white ribbon filter papers are used. A study of the suitability of various grades and types of filter paper for the separation of amino acids by different solvents resulted in the following classification of the filter paper :

- (1) Degree and clarity of separations.
- (2) Diffuseness of spots.
- (3) Degree of formation of stains or streaks, presumably caused by the impurities in the paper.
- (4) Extent of formation of tails or zones other than amino acids, giving colour reactions with ninhydrin.
- (5) Deviation from vertical movement.
- (6) Rate of movement of solvent front.

## Paper Chromatography for Amino Acids, Amines and Peptides

### Solvents (for amino acids)

Out of several solvents employed for the separation of amino acids and peptides, the following four are the most useful :

- (1) **Phenol** : 100 milliliters of metal-free water is dissolved in 400 ml of liquid phenol and 25 to 50 mg of 8-hydroxyquinoline is also added. The solvent may be stored in a dark bottle in the refrigerator. Before using, shake well and gently warm. The relative distance ( $R_F$ ) travelled by the more basic amino acids, arginine, lysine, ornithine, hydroxylysine in phenol is influenced by the pH of the developing medium.
- (2) **Lutidine-ethanol** : This solvent is made by mixing 55 ml of 2, 6-lutidine, 25 ml of ethanol, 20 ml of water and 2 ml of diethylamine. This solvent is completely miscible. 2,6-lutidine, 2,4,6-collidine and water (1 part each).
- (3) **Lutidine-collidine** : It is made by mixing 2,6 lutidivo, 2, 4, 6-collidine and water (1 part each).
- (4) **Butanol-acetic acid** : This solvent is made by adding 60 ml of glacial acetic acid to 500 ml of a freshly shaken mixture of equal volumes of water and n-butanol. Two layers are formed. The upper layer is used as the moving phase.

### Specific reagents (for amino acids)

The following specific reagents are described for some amino acids :

- (1) **Arginine** :  $\alpha$ -naphthol-hypochlorite reaction. The chromatograms are sprayed with 0.1% solution of  $\alpha$ -naphthol in 1N NaOH. After drying, paper is sprayed with NaClO. Arginine appears as a red spot.
- (2) **Cystine** : The paper is dipped into 1% of  $\text{Na}_2\text{SO}_3$  and partly dried in air. The damp chromatogram is treated with Folin's phospho-18-tungstic acid and the reagent is made alkaline with  $\text{Na}_2\text{HCO}_3$ . Cystine and other reducing substances give a deep blue colour.
- (3) **Citrulline** : This amino acid is near glutamine on two-dimensional chromatograms and is best detected by spraying with 1% solution of p-dimethylaminobenzaldehyde in 1N HCL. It gives a yellow spot.

- (4) **Glycine** : Glycine, histidine and tryptophane give a colour when sprayed with Zimmerman's o-phthalaldehyde reagent.
- (5) **Ornithine** : Ornithine and glutamic acid have been reported to give three and four spots on butanol-acid chromatograms after acid hydrolysis.

**Separation of free amino acids and peptides in tissues**

For detecting free amino acids and peptides in plant or animal tissues, other constituents may be removed as far as possible. Dialysis or precipitation with trichloroacetic acid, tungstic acid, ferric hydroxide, zinc sulphate, barium hydroxide at pH 7.2-7.6, perchloric acid, acetone and ethanol is done. Grind the tissues with sufficient absolute ethanol in a blender, so that the final concentration of alcohol is 80% by volume. The insoluble material is removed by filtration and washed with 80% ethanol.

**Class Experiment for Amino Acids Chromatography**

**Experiment** : Detection of amino acids by two-dimensional paper chromatography.

**Requirements** : Chromatography chamber, ethyl alcohol, phenol, water imbibed seeds or animal tissue, butanol, glacial acetic acid, water, ninhydrin, spray agent, capillary tubes, staples and stapler, spraying apparatus (atomizer), pistol mortom, conical flasks (100 ml), pencil, Whatman No. 1 paper, glass rod, spirit lamp or Bunsen's flame.

**Procedure** : (1) Clean the **pistol-mortom**. Grind 10 gm of animal tissue of germinating seeds in 50 ml of absolute ethyl alcohol. Grinding may be done in a blender also. Filter and evaporate the filtrate to

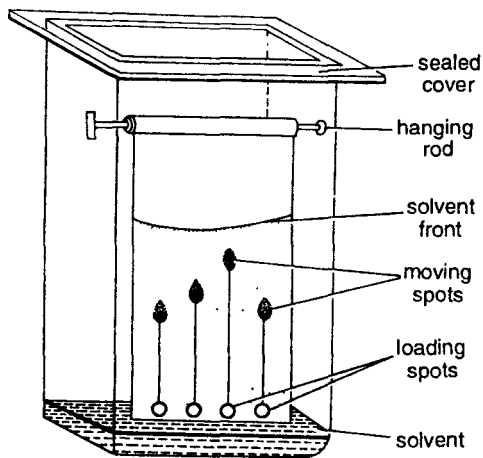

Fig. 1. Chromatography chamber.

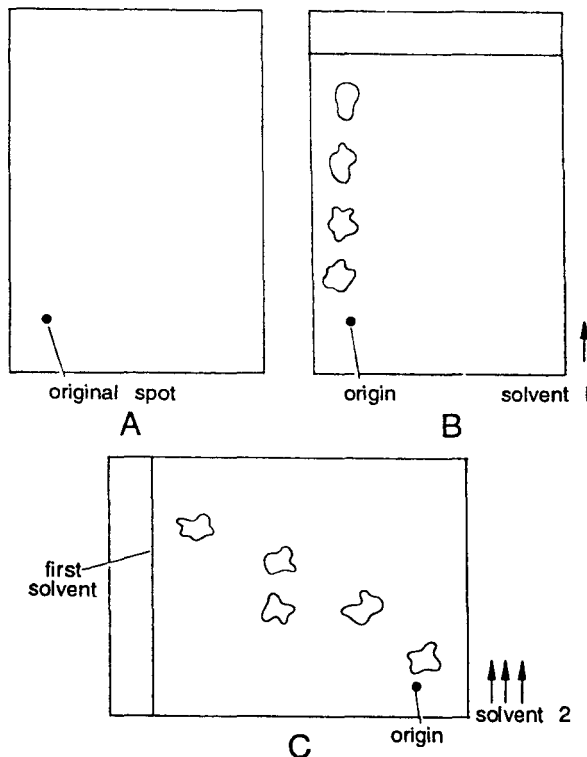

Fig. 2. Two dimensional chromatography.

Table 1. Showing  $R_F$  values for certain amino acids in different solvents.

Amino acids	Solvents				
	Acetone-urea water	1, Butanol-acetic acid water	2, 6 Latidinecoldin water	Phenol water	Pyridine-ethanol water
1. $\alpha$ -Alanine	0.34	—	0.28	2.60	0.54
2. w-Alanine	—	0.37	0.22	0.66	—
3. Arginine	0.34	—	0.17	0.89	0.31
4. Aspartic acid	0.18	—	0.21	0.19	0.43
5. Cystine	0.16	—	—	—	—
6. Glutamic acid	0.18	—	0.20	0.31	0.48
7. Glycine	0.21	—	0.12	0.12	—
8. Histidine	0.25	—	0.27	0.69	0.43
9. Isoleucine	0.59	—	0.54	0.84	0.66
10. Lysine	0.25	—	0.11	0.81	—
11. Methionine	0.55	—	0.42	0.81	0.66
12. Proline	0.56	—	0.28	0.88	0.56
13. Ornithine	0.65	—	0.11	0.79	—
14. Serine	0.65	—	0.28	0.36	0.51
15. Phenylalanine	0.63	—	0.48	0.85	0.66

(After Block, Durrum and Zweing-Paper Chromatography)

dryness. Redissolve the evaporated filtrate solid in double distilled water to make up the volume of extract to nearly 2 ml. For class students and for beginners, mixture of known amino acids may be preferred as described above. Glycine, aspartic acid, phenylalanine, tyrosine and tryptophane may be taken.

- (2) Take glass-walled chromatography chamber. In one chamber fill phenol and in the other n-butanol-acetic acid water solvent (3 : 1 : 1) and keep the level of the solvent half an inch above the bottom of the chamber.
- (3) Cut **Whatman No. 1** filter paper into strips according to the size of the chromatography chamber. Mark a small circle on the cut strips by pencil about 1 inch from the bottom and 2 inches from the left hand edge. Apply a small amount of extract on the pencil-marked circle by glass rod. Hang the chromatogram with extract dot at the base and allow the extract to become dry. Dip the paper edge in the solvent, keeping the pencil mark above the solvent. Close the chamber, make it airtight and permit 16 to 18 hours to develop the chromatogram.
- (4) Remove the chromatogram and let it become dry, marking the position of the solvent. Turn the paper 90°, place the paper in this direction in another chamber containing solvent or n-butanol-acetic acid water. Let the chromatogram develop for 10 to 12 hours in chromatography chamber. Remove the paper and spray uniformly with 0.1% ninhydrin (0.1 gm of ninhydrin mixed in 100 ml saturated n-butanol water). Heat the paper at 90°C for 2 to 5 minutes. Circle the spots with pencil.
- (5) Calculate the  $R_F$  value and compare it with standardised values. Different colours are given by different amino acids.

## Paper Chromatography for Carbohydrates

One- and two-dimensional paper chromatography makes it possible to separate various sugars. Polysaccharides may be hydrolyzed and hydrolyzates may be treated like other simple sugar mixtures. The quantitative evaluation of the sugar chromatographs can be achieved by a visual or photoelectric comparison of the optical density of coloured spots.

**Choice of the filter paper :** Generally **Whatman No. 1** filter paper is preferred but **Schleicher and Schnell No. 589** and white ribbon may also be used.

**Solvents :** For chromatographic development of sugars, ascorbic acid and related substances, the following solvents must be specially treated to retard the decomposition of ascorbic acid by heavy metal ions present in the paper or solvents :

- (1) 60 milliliters of n-butanol is shaken with 40 ml of water and an excess of oxalic acid. The mixture is allowed to settle in a separatory funnel. Use upper layer.
- (2) Dissolve 50 gm of phenol crystals in 10 ml of charcoal-filtered water and add excess of oxalic acid. Mixture is allowed to settle in a separatory funnel and use lower layer. For further refinement, the filter paper is washed to solvent development with 2% oxalic acid.
- (3) Presence of inorganic salts  $\text{Na}_2\text{SO}_4, \text{Na}_3\text{PO}_4$  often produces artifacts and retardation of spots with basic solvents. However, the solvents n-propanol : ethyl acetate : water (7 : 1 : 2) gives excellent result for sugar chromatography.
- (4) For two-dimensional separation of many simple sugars, phosphorylated sugars, organic acids, the following solvent pair is recommended :
  - (a) **First direction** : Liquid phenol water (100 : 20). The mixture is neutralized to pH 5-6.
  - (b) **Second direction** : (A) Butanol water, (B) Propionic acid water. Just before use mix equal volumes of A and B warm slightly to form a single phase solvent.
- (5) The following pair may be used for two-dimensional ascending chromatography :
  - (a) **First direction** : n-butanol : pyridine : water (3 : 2 : 1.5).
  - (b) **Second direction** : Phenol saturated with ammonical water and small amount of 8-quinolinol.
- (6) For the separation of sucrose, glucose, fructose and sorbitol the following solvents are recommended :
  - (a) **First direction** : Benzene : n-butanol : pyridine : water (1 : 5 : 3).
  - (b) **Second direction** : Amyl alcohol : pyridine : water (1 : 1 : 2).

**Table 2. Showing  $R_F$  values of some sugars (After Block).**

Sugar	Solvent systems			
	Water-saturated phenol + 1% $\text{NH}_3$	Water-saturated collidine	n-butanol : acetic acid water (Descending)	n-butanol : acetic acid : water (Horizontal)
D-glucose	0.39	3.39	0.18	0.43
D-galactose	0.44	0.34	0.16	0.41
D-mannose	0.45	0.46	0.20	0.46
D-fructose	0.51	0.42	0.23	0.48
D-xylose	0.44	0.50	4.28	0.53
Lactose	0.38	0.24	0.09	0.33
Sucrose	0.39	0.40	0.14	0.39
Maltose	0.36	0.32	4.11	—
D-deoxyribose	0.73	0.60	—	—

## Class Experiment for Sugar Chromatography

**Experiment :** Separation of sugars by paper chromatography.

**Requirements :** Some unknown 1% sugar solutions (preferably from some plant extract), 1% solutions of glucose, fructose, rhamnose, sucrose, arabinose, ribose and galactose, solvent I (t-butanol : glacial acetic acid : water, 3 : 1 = 300 ml), solvent II (phenol : water, 4 : 1 = 30 ml), spray agent p-anisidine, 2 chromatography jars (10 by 18 inches) with ground glass lids, grease, oven maintained at 80°C, chromatography paper Whatman No. 1, pencil, ruler, scissors, micropipette and atomizer or other spray device.

**Procedure :** (1) Chromatography jars should be made airtight. Apply a little grease over the mouth rim of the jar. Mark the jars A and B. Keep solvent I in jar A and solvent II in jar B. Each jar should contain one half inch of the solvents. Cover the jars and allow the internal atmosphere to equilibrate for several hours before the use.

- (2) Cut 2 strips of Whatman No. 1 chromatography paper, according to the size of the chromatography jar. The papers should be cut carefully, avoiding any contact with fingers or other substances which might contribute interfering chemicals.
- (3) Lay two cut strips of paper on a clean surface with long axis parallel to the table edge. Draw a pencil line two inches above the edge of one of the long sides. Make a series of pencil dots at one inch intervals along the line and label these dots as fructose, glucose, sucrose, arabinose, ribose and rhamnose. The two papers or strips should be duplicate which will be kept into separate solvents.
- (4) Arrange the sheets to overlap a support such as a glass tube or meter stick in such a way that the pencil spots are raised above the surface of the table.
- (5) Apply intermittently 3 micromilliliter of sugar solutions on the appropriate spot and allow them to become dry.
- (6) Now staple the dry sheets separately in such a way as to form a cylinder and this chromatogram may be allowed to develop in solvent I and II separately for 10 to 12 hours. Cover the jars and leave the chromatogram until the solvent front approaches the upper edge of the paper.
- (7) After development mark the solvent and hang the papers to dry. When dry, spray the papers with p-anisidine reagent with atomizer and keep the chromatograms in 80°C maintained oven for 3 minutes. Circle the resulting spots with pencil and note the colour. Calculate the  $R_F$  (Table 2) values of each sugar and compare with standard values. Make a table showing results.

**Table 3. Showing result of ascending paper chromatography of known sugars (Unknown sugars).**

Compound	$R_F$ value in solvent I-colour	$R_F$ value in solvent II-colour
1. Glucose		
2. Fructose		
3. Rhamnose		
4. Arabinose		
5. Sucrose		
6. —		

## EXPERIMENTS ON PHYSIOLOGY

The physiology practical exercises consists of the following. Muscle contraction by recording drum, heart beat *in situ* by recording drum, experiments with blood, blood groups and Rh-factor and experiments with urine using human urine sample.

### MUSCLE CONTRACTION

Recording drum is used for above experiments. Complete apparatus used for such studies is divided into two categories : (i) non-electrical parts, and (ii) electrical parts.

#### A. Non-electrical Parts

- (1) **Dissecting board** : It is a rectangular wooden board of 6" × 8" size containing elastic bands on 4 corners to fix 4 extremities of the frog (hands and feet).
- (2) **Rectangular tray** : It is made up of aluminium or stainless steel measuring 8" × 10". It is deep enough to accommodate the dissecting board.
- (3) **Adjustable stand** : It is composed of a heavy metal base and long vertical middle rod having a screw near its base, so that it may be rotated.
- (4) **Myograph board** : It is covered with paraffin wax on top. On one side it has a top or head for fixing it to myograph lever, while on the other side a fork is attached. Top surface is provided with raised margins to keep Ringer's solution for keeping the nerve-muscle preparation moist.
- (5) **Myograph lever** : It magnifies the contractions. It is a crank type of myograph lever in which the fulcrum of the lever is near one end of the myograph board. Lever has a vertical short stem and a long horizontal arm. Muscle can be located by hook and the weight is hung over the long arm. It can be adjusted in such a way that the muscle and the treated are not freely stretched by the load during rest.
- (6) **Pithing needle** : It is used to pith and kill the frog.
- (7) **A pair of hand gloves.**
- (8) **Recording drum** : It comprises of both mechanical and electrical parts. It is composed of a heavy metal base with two screws in front for levelling. Drum is electrically operated having an electrical switch at right side to control the main power of 220 volts. Below this is a mechanical screw. This screw keeps the drum off, if placed horizontally, and on when in vertical position. For speed control there are two bars on left side. These bars are fitted in marked end and the drum will not move if it is at neutral point. At the base of the drum, there is a vertical metallic rod, which rotates and possesses a hollow metallic cylinder 6" long. Over the rod is a guiding pin through which the slot of drum must pass. Outer surface of the drum is tightly covered by a glazed and smoked paper for recording the contraction or the heart beat.

#### B. Electric Parts

- (1) **Recording drum** : The electrical part of the drum consists of two terminals, one black and other red, connected to the source of the current. Lower end of the rod contains two metallic pins. Inside the terminals is a metallic spring which gives contact-make and contact-break, during each rotation.
- (2) **Induction coil** : It is used to convert low voltage current to high voltage. It is composed of primary and secondary coils. When the current passes through the primary coil, there is a change of flux and an induced current is produced in secondary coil. This change is brought about by make and break arrangement. Primary coil is of thin copper wire wrapped on a soft iron core and a secondary coil

of thin copper with large number of turns. Secondary coil may be kept close or away from the primary circuit.

- (3) **Keys :** Keys are used for interrupting the course of the current. For adjusting primary circuit, short circuiting is used and for secondary circuit, secondary key or Du Boys Reymond key is used. Drum must always be rotated, clockwise and the mechanical screw must be kept off.

### C. Experiments

#### **Experiment (1) To prepare gastrocnemius muscle nerve.**

**Procedure :** While making muscle nerve preparation, following rules must be observed :

- (1) Never use a knife when experimenting on a frog, but cut with scissors only.
- (2) Do not touch the nerves with instruments.
- (3) Always keep the tissues, especially the nerve, moist with 0.6% NaCl solution.
- (4) Always pith the frog for above preparation.

**Pithing :** For pithing, take a living frog and catch it firmly in the left hand. Make a bold incision into the skin transversely along outside cutting the atlanto-occipital ligament and pass the pithing needle into the skull above the exposed spinal cord to destroy the central nervous system by moving the needle to and fro, forwards and backwards. Take out the needle, pass it downwards through vertebral canal performing side to side movement of the pithing needle, so as to destroy the spinal cord. Complete destruction of the spinal cord is ensured by the absence of cutaneous reflex of the hind limbs.

**Preparation of muscle nerve :** (1) Cut the pithed frog across about 1 cm anterior to the sacro-iliac joints, remove any viscera remaining in the body cavity. Cut the skin between the legs, catch the skin at the transverse cut with the finger and thumb of one hand and the end of the spinal column with the other and pull the skin downwards towards the toes. It will be peeled off easily and cleanly. Leave the second leg covered with skin.

- (2) Lay the legs on their ventral surface, grasp the urostyle with forceps and remove it by cutting away the muscle on both sides, and finally cut it from the end of the spinal column. Turn the preparation to the dorsal side and observe the sciatic nerve lying against back of the abdominal cavity. Snip through the sacro-iliac joint on the side of the skinned leg, dissect the end of the spinal column longitudinally, by means of one strong steady cut with scissors, carefully avoiding injury to nerves. By holding the piece of vertebrae so isolated, the dissection of the nerve can be carried out without pinching it with forceps. Lay the preparation on the ventral surface and pin it firmly to the dissecting board.
- (3) Now holding the piece of the bone with forceps, dissect the nerve down towards the thigh, separate the muscular masses on the dorsal side of the thigh, carefully keeping in mind for the sciatic nerve and artery lying side by side. Continue the dissection upto the knee, do not let nerve lie on the skin of the frog, moisten with normal saline. Tie a ligature round the Achilles' tendon, cut this on distal side, snip through connective tissue attaching the gastrocnemius muscle to the leg. Cut through the leg bone just below the knee, and the whole thing just above the knee, carefully leaving gastrocnemius muscle and the sciatic nerve intact. Don't dissect the nerve at the knee.

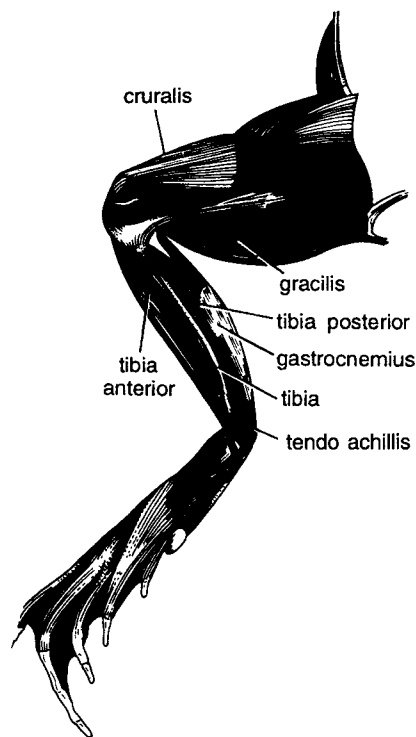

Fig. 3. Frog : Gastrocnemius muscle.

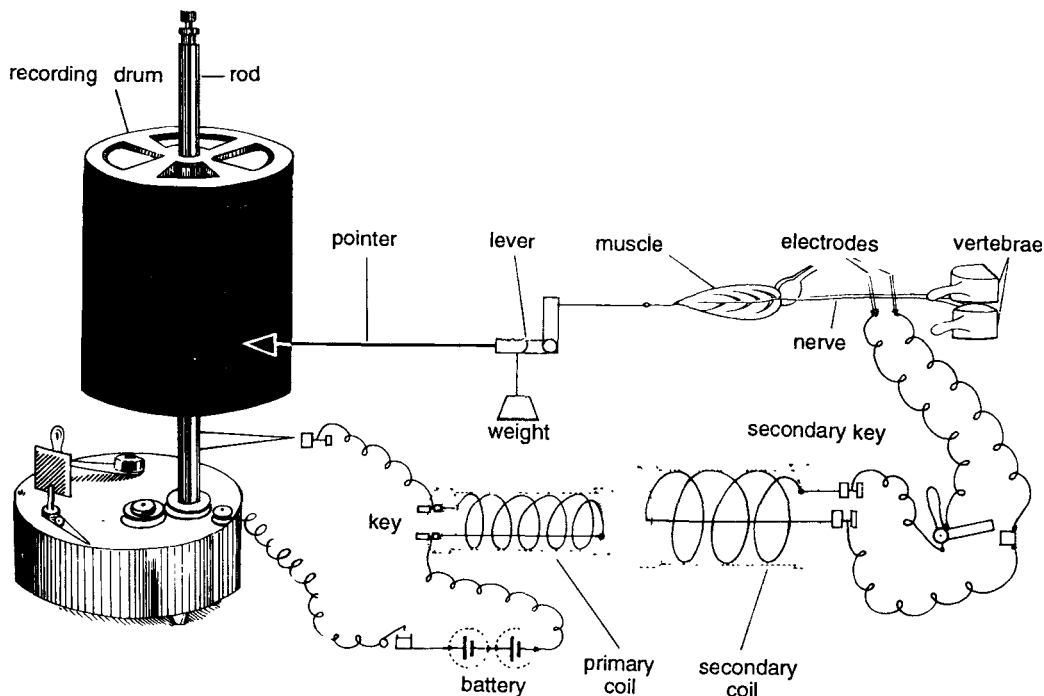

Fig. 4. Connection, recording drum and nerve muscle for simple muscle contraction.

(4) The nerve muscle preparation is now complete which consists of vertebrae with origins of sciatic nerve, knee joint, gastrocnemius, muscle, tendon and thread. Fasten it on to the myograph board with a pin through the knee joint, attach the thread to the short arm of the level, so that preparation is ready for experimentation.

**Experiment (2) To demonstrate or draw a simple muscle curve (simple twitch).**

**Requirements :** Dissecting board, adjustable stand, crank myograph, pointer, recording drum or kymograph, primary key, induction coil, short circuiting key, electrodes, connecting wires, pithing needle, scalpel, scissors and hand gloves.

**Connections :** It consists of primary circuit with drum in circuit. In the secondary circuit, the two terminals of secondary coil are connected to the two side terminals of the short circuiting key. Current from the other two terminals of the short circuiting key is led to the electrodes which are used to stimulate the muscle through its nerve. Speed of the drum is kept fast.

**Procedure :** (1) After making all the necessary connections, adjust the base of the recording drum in the horizontal position by levelling the screws. Wrap the smoked paper around the recording drum and making a baseline on the recording drum.

(2) Place the gastrocnemius sciatic preparation on the myograph, connect the tip of the muscle with the vertical limb of the myograph lever and insert a pin below the knee joint. Other end of the sciatic nerve is laid on the electrodes. Adjust the pointer on the drum to draw the curve.

(3) Apply the current on the nerve.

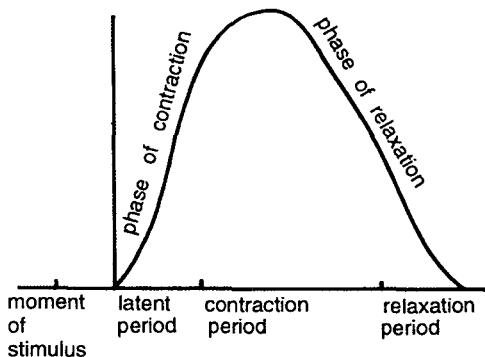

Fig. 5. Simple muscle twitch curve.



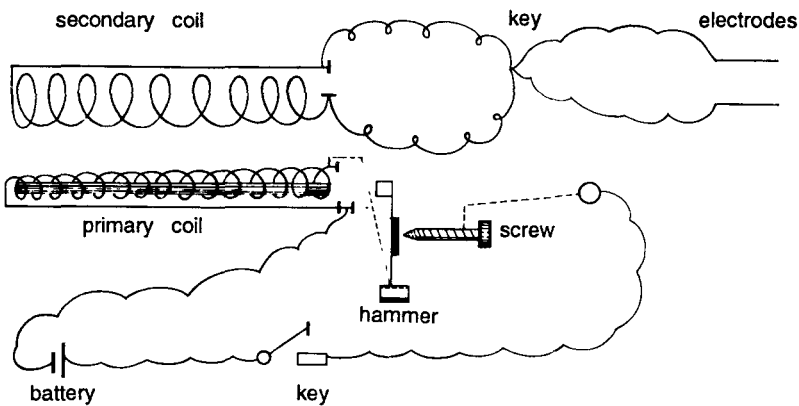

Fig. 6. Connection of tetanus.

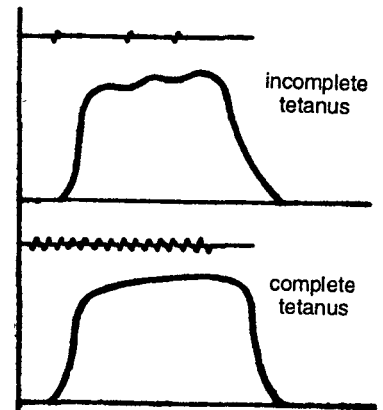

Fig. 7. Complete and incomplete tetanus curves.

**Observations :** When the electrical stimulus is applied to the sciatic nerve, the gastrocnemius muscle contracts and a curve is drawn on the smoked paper. This curve shows moment of **stimulus**, **latent period**, **phase of contraction** and **phase of relaxation**.

**Precautions :** (i) Switches should be used very carefully. (ii) Connections should be tight. (iii) Place of recording drum must be in the horizontal position.

**Experiment (3) To demonstrate the phenomenon of completed tetanus.**

**Apparatus :** As given in the case of muscle twitch. Connections are adjusted in such a way that the rate of movement of the hammer of induction coil becomes very high and the speed of the drum is kept very slow.

**Observation :** Fix a gastrocnemius muscle preparation on the myograph board. Draw a baseline on the drum. Rotate the drum very slowly. Give one stimulus to cause muscle contraction, then give multiple stimuli.

**Procedure :** A complete tetanus curve is observed. It is observed that, due to a very high rate of movement of the hammer of induction coil the rate of interruptions of the current becomes very fast and successive contractions fused together as a continuous curve.

Rapid and multiple stimulations to muscle fibres leave no time to relax them. Response is smooth, sustained and maximal. Such a response is termed as **tetanus**. For demonstrating incomplete tetanus less rapid stimulations are given. In this case, contraction is not smooth and individual waves may be discerned. If a muscle is stimulated respectively for a long enough period of time, the force of contraction progressively decreases and finally a point is reached at which no contraction occurs. In this case a muscle is said to be fatigued.

**Experiment (4) To record the heart beats of the frog *in situ*.**

**Apparatus :** Recording drum, myograph board, dissecting board, pithing needle and a large size frog.

**Dissection of frog's heart (Procedure) :** (1) Lay the pithed frog on its back on the frog board and fix it with 5 pins-four through the limbs and one through the jaw.

(2) Make a median incision through the skin over the sternum, lift the cartilaginous xiphisternum and separate it from underneath by cutting through the small strands of tissue. Make an incision on each side of the cartilage, insert under the pectoral girdle the pointed blade of a pair of strong scissors, keeping the blade in close contact with the bone.

(3) Divide the girdle first on one side and then on the other, raise and cut away the anterior wall of the thorax. Pull both forelimbs laterally and fix them in such a position as to keep the chest wide open.

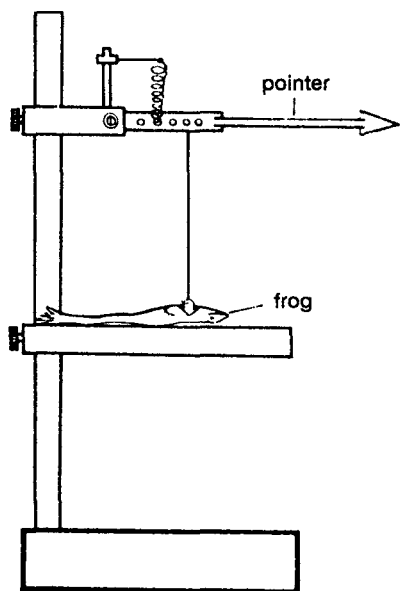

Fig. 8. Heart beat record of frog.

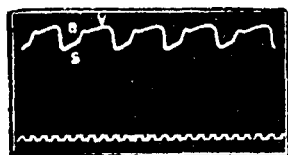

Fig. 9. Normal heart beat recording of frog.

- s = Contraction of sinus.
- a = Contraction of auricle.
- v = Contraction of ventricle.

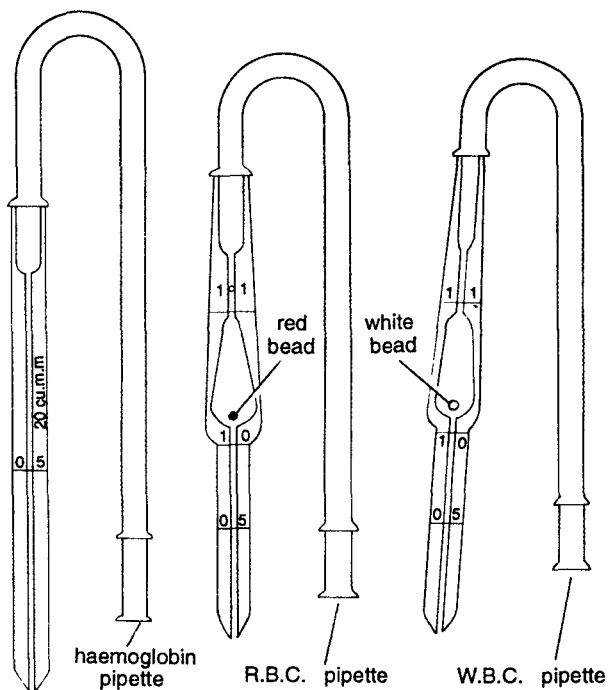

Fig. 10. R.B.C., W. B. C. and haemoglobin pipettes.

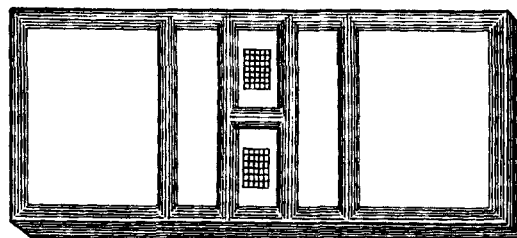

Fig. 11. The Burkler Hawksley counting slide.

**Inspection of the frog's heart :** Carefully make an incision in the pericardium and find the ventricle, two auricles, auriculo-ventricular groove and bulbous arteriosus. Lift the ventricle upwards and locate the sinus venosus and superior and inferior venae cavae.

**Sequence of the heart beat :** Contractions of the frog's heart are progressive. Sinus leads off first and is followed by the auricles, ventricle and the bulbous last. Rhythm of the heart beat is dependent on the frequency of the sinus. Observe how the ventricle during contraction, changes its colour becoming pale when free from blood in **systole**. Also observe the short pause between the contraction of the **sinus** and the **auricles** and between that of the auricles and **ventricle**.

**Record of the heart beat :** Pass a hook, made from a small pin, in the apex of the ventricle or use a special heart clip. Lift the heart very gently by the thread attached to the hook and snip through the fraenum. Insert a pin through the bulbous part and fix it to the frog board. Fasten the free end of the thread with the lever and adjust the lever over the drum. Record the movements of the beating of heart on a slowly moving drum.

**Precautions :** (i) During dissection never use the knife. Use scissors only. (ii) Never injure the heart. (iii) Select a large frog. (iv) Once the frog has been pithed, perform the experiment with as much

speed as you can. (v) Never pinch the nerves with forceps. (vi) Prevent the tissues from drying by frequently bathing them with 0.78% NaCl solution.

**Experiment (5) : To study the effect of adrenaline on the heart beat of frog *in situ* by perfusion method.**

**Requirements :** A living frog, recording drum, smoke paper, myograph board, adrenaline, sodium chloride, potassium chloride, sodium bicarbonate, calcium chloride, distilled water, 1000 cc flat bottom flask. Perfusion apparatus (a large funnel and a rubber tube) injection syringe and a glass canula.

**Procedure :** (1) Fix the frog by the method described in experiment no. 4 for recording heart beat. Effect of drugs is studied by perfusion method.

- (2) After exposing the heart of frog, insert a glass canula in posterior vena cava.
- (3) Fix the perfusion funnel at a suitable height and connect the tube with the glass canula. Put a fluid regulating clip below the neck of the funnel over rubber tube.
- (4) Fill the perfusion funnel with Ringer's solution which is made by the following distilled water in a 1000 cc flat bottomed flask.
 

Sodium chloride	= 30 gm
Potassium chloride	= 0.375 gm
Sodium bicarbonate	= 0.05 gm
Calcium chloride	= 0.05 gm
Distilled water	= 500 cc
- (5) Regulate the flow of Ringer's solution which passes through the sinus venosus, auricle and ventricle. Make a small cut in ventricle by a surgical blade. Small cut permits exit of perfused Ringer's solution. Record the heart beat of the perfused heart.
- (6) With 7 : 1000 ratio (7 cc of liquid adrenaline + 1000 cc of Ringer's solution) inject adrenaline into rubber tube of perfusion apparatus and observe the heart beat recorded on smoke paper.

**Observation :** The heart beat of frog is increased as adrenaline in a sympathomimetic drug. Fix the recording of heart beat on smoke paper is dilute varnish fluid. Dry the paper and study the heart beats of perfused and adrenaline injected heart beats. By above procedure hearts can also be recorded and studied by Acetylcholine injection. Acetylcholine is a parasympathomimetic drug and it represses or decreases the heart beat.

## Experiments of Blood, Blood Groups and Rh Factor

**Experiment (1) Enumerate the total R.B.C. (Red Blood Cells or Erythrocytes) count of your own blood.**

**Apparatus :** Haemocytometer, sterilized pricking needle, R.B.C. pipette, compound microscope and Hayem's diluting fluid (NaCl - 1%, Na<sub>2</sub>SO<sub>4</sub> - 2.5% and HgCl<sub>2</sub> - 2.5%).

**Haemocytometer** is a kind of slide containing counting chambers. The **Burker, Neubaur, Thoma** or any other haemocytometer may be used. The Neubaur haemocytometer consists of a double-cell slide with two sunk platforms in open cell type. Each platform has a ruling so that rapid duplicate counts can be made. When a special cover glass is kept in position, a depth of 1/10 mm is maintained over the rulings. Diluted blood is run on by capillary force after the cover glass has been fixed. Counting chambers are nine large squares having sides of 1 mm each. Central large square ABCD is subdivided in 25 medium squares and each medium square in turn contains 16 tiny squares having sides 0.05 mm long. Hayem's diluting fluid may be kept as stock solution and a small amount of it may be taken in watch-glass, so that entire solution may not be mixed with the blood.

**Procedure :** (1) Clean and dry mixing pipette (dilution 1 : 200).

- (2) Sterilise your middle finger and the puncturing needle (preferably over a flame) with a small pad of cotton wool dipped in 90% alcohol.

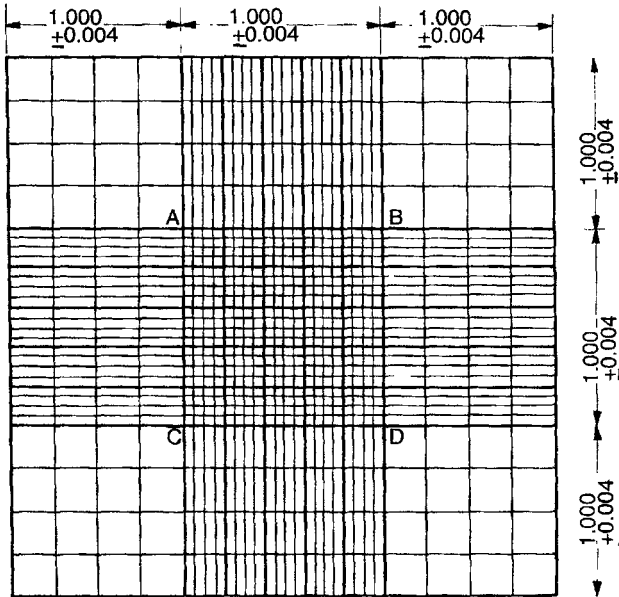

Fig. 12. Ruling of improved Neubaur slide.

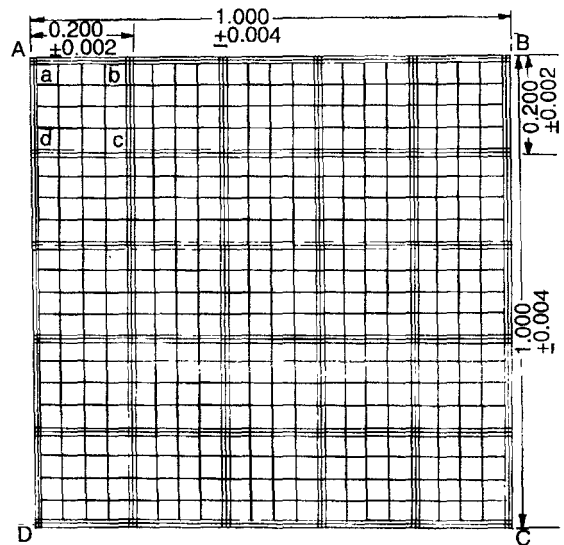

Fig. 13. Magnified view of central A, B, C, D squares.

- (3) Pick the middle finger with the puncturing needle so that blood flows freely. Don't squeeze.
- (4) Wipe away cleanly the first few drops, then suck the blood with R.B.C. pipette upto the 0.5 mark slowly and carefully. If the blood has been drawn up too far, the excess may be removed by wiping the end of the pipette suitably drying on blotting paper.
- (5) Wipe the excess blood from the tip of the pipette and immediately mix it with Hayem's diluting fluid and suck in R.B.C. pipette the diluting blood upto 101 mark. Hayem's fluid prevents haemolysis, rouleaux formation, coagulation and bacterial growth. Disconnect the rubber tube, grip the ends of the pipette between forefinger and thumb and shake thoroughly for a minute.
- (6) Re-attach the rubber tube to the pipette, reject the unused diluting fluid in the stem of the pipette. Avoid drying and quickly run the diluted blood under the cover glass on to each of the central platforms. If unable to do so, wash the slide and the cover glass and repeat it until you become expert. The acquirement of skill in performing procedure No. 3 and 6 is very essential and otherwise the counting will be valueless. The correct size of the blood drop and speed is obligatory in order to avoid uneven distribution of the cells. Very large drop will result in low count because the cells tend to be sucked down into the trough away from the counting grid. On the contrary, a very small drop, so that a second drop is to be added, results in high count due to the uneven distribution of cells at the junction of the two drops. Once an optimum drop has been placed, the cells should be allowed to settle for one minute and then counting should be done.
- (7) Bring counting scale into the focus under the objective under a microscope. Count cells in 16 squares in five different parts of the field. The counting should be done exact replica of the squares drawn on your copy. Any corpuscle lying on lines should be moved either upwards or to right side.

**Calculations :** These may be done in the following manner :

$$\text{Number of R.B.C. per cubic mm} = \frac{\text{Number of cells counted} \times \text{Dilution} \times 400}{\text{Number of small squares counted}}$$

Suppose, five smaller squares, or 80 smallest squares contain A+B+C+D+E R.B.Cs.

One smallest square will contain A+B+C+D+E //80 R.B.Cs.

400 smallest squares will contain A+B+C+D+E × 400//80 R.B.Cs.

But, height of chamber = 0.1 mm and dilution of blood = 200 times.  
Therefore, one cubic mm of blood will contain :

$$\frac{A+B+C+D+E}{80} \times 400 \times 10 \times 200 \text{ R.B.Cs.}$$

$$= A+B+C+D+E \times 10000 \text{ R.B.Cs.}$$

**Experiment (2) Enumerate the total W.B.C. (leucocytes) count of your own blood.**

**Apparatus :** W.B.C. pipette, haemocytometer, Hayem's fluid, microscope.

**Procedure :** (1) Clean and dry the W.B.C. pipette.

- (2) Sterilise the tip of your middle finger and puncturing needle with a pad of small cotton wool dipped in 90% alcohol.
- (3) Prick the sterilised finger deeply with the needle so that blood oozes freely without squeezing.
- (4) Discard the first drop and then suck the blood in W.B.C. pipette upto 0.5 mark and immediately dilute the blood with Hayem's solution 20 times up to 11 marks.
- (5) Rotate the pipette slowly so as to allow the blood to mix with diluting solution.
- (6) Place clean coverslip on already cleaned counting chamber and add immediately and rapidly a drop of mixture to the edge of the coverslip after discarding the clear fluid in the capillary part. Allow the corpuscles to settle down and make a count under the microscope.
- (7) White blood cells are recognised under low magnification by their refractile appearance and by slight colour given to them by the diluting fluid. Counting is performed in the four corners of 1 square millimeter.

**Calculation :** Number of leucocytes per cubic mm is calculated as follows :

$$\text{Number of leucocytes per cubic mm} = \frac{\text{Number of cells counted} \times \text{Dilution} \times 10}{\text{Number of 1 sq. mm counted}}$$

**Experiment (3) Find out the haemoglobin percentage of your own blood.**

**Requirements :** Haemoglobinometer and N/10 HCl.

**Procedure :** (1) Prick the finger as described earlier. discard the first drop and suck the blood in the pipette upto 0.2 ml mark.

- (2) Transfer the blood into the carefully cleaned haemoglobinometer tube containing small amount of N/10 HCl.
- (3) Add N/10 HCl again drop by drop into the tube and constantly match the colour of the mixture with the colour of adjacent tubes of either side of the instrument. Continue this until the colour of the mixture exactly matched with the standard colour.
- (4) Find out the end point. It may be found out by noting the point where the colour of the solution becomes lighter by addition of very next drop. Take more than one reading to avoid error. Amount of haemoglobin in the above experiment comes to 14.5 gm. By addition of N/10 HCl, a definite quantity of haemoglobin is converted into acid Haematin.

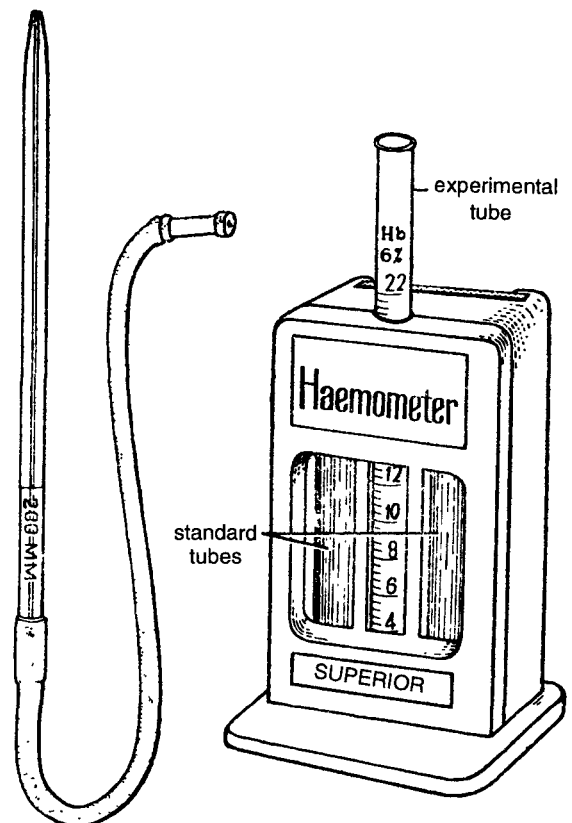

Fig. 14. Gower's Haldane Haemometer.

**Experiment (4) Preparation of haemin crystals.**

**Procedure :** Haemin crystals may be prepared from your own blood.

- (1) Wash your hands with soap, clean the middle finger with rectified spirit and allow it to dry in the air.
- (2) Prick this cleaned finger with the sterilized needle smartly and take a drop of blood on the clean slide.
- (3) Allow the blood to dry completely.
- (4) Put a drop of glacial acetic acid and dry the slide over the Bunsen's burner or spirit lamp.
- (5) Cool the slide and examine it under microscope.

**Observation :** Steel grey small **haemin crystals** are seen in large numbers.

The blood drop with glacial acetic acid forms acid haematin which on heating forms haemin crystals.

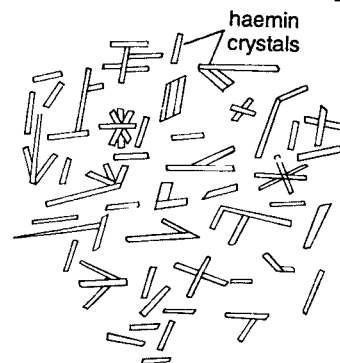

Fig. 15. Haemin crystals.

**Experiment (5) Estimation of haematocrit value in a blood sample of rat or any other animal like sheep and goat.**

**Principle :** When any blood sample is centrifuged, then **erythrocytes** or RBCs separate and settle down.

**Plasma** is seen as a clear liquid. The settled RBCs represent PCV (packed cell volume) which is referred as haematocrit. PCV can be calculated by standard **Wintrobe method** as under.

**Requirements :** Blood sample (self or sheep or goat, or rat), centrifugal tubes, EDTA (Ethylenediamine triacetic acid) as anticoagulant and a high speed centrifuge.

**Procedure :** (1) Clean the graduated centrifuge tube with Di-chromic sulphuric acid glass cleaning solution ( $K_2Cr_2O_7$  100 gm, water 200 cc and dilute  $H_2SO_4$  800 cc).

- (2) Wash the tubes 12 times with tap water and 3 times with distilled water.
- (3) Dry the tubes in incubator.
- (4) Take a freshly chloroformed rat, dissect quickly and puncture the heart.
- (5) Add a little EDTA in centrifuge tubes and collect 10 cc of blood in each centrifuge tube.
- (6) Keep the blood containing centrifuge tubes in the centrifuge. Centrifuge the blood sample at 3000 rpm (revolutions per minute) for 30 minutes for applying sufficient relative centrifugal force (RCF) for the separation of plasma and blood cells. Dark coloured settled blood cells and a clear yellowish plasma will be seen.

**Observations :** Observe the following :

- (1) Volume of blood – 5 cc
- (2) Volume of the plasma – 3 cc
- (3) Volume of the blood corpuscles – 2 cc

Calculate PCV by the following formula :

$$PCV = \frac{\text{Volume of the blood corpuscles}}{\text{Volume of blood}} \times 100 = \frac{2 \times 100}{5} = 40\%$$

$$\text{Plasma} = \frac{3 \times 100}{5} = 60\%$$

**Result :** Haematocrit value or PCV = 40%.

**Experiment (6) Examination of Human Blood Group.**

**Principle :** Karl Landsteiner discovered blood groups. According to him **absence** or **presence** of A or B agglutinogens or A and B antigens in Red blood cells (R.B.C.) blood groups are classified as under into 4 types.

- (1) **Blood group 'A'** : Persons with A blood group have **agglutinogen-A** or **antigen-A** over surface of R.B.C. and antibodies **B** or agglutinin-B in plasma.
- (2) **Blood group 'B'** : Persons with B blood groups have **agglutinogen-B** or **antigen-B** over surface of R.B.C. and **antibodies-A** or **agglutinin-A** in plasma.

- (3) **Blood group -‘AB’** : Persons with AB blood groups have **agglutinogen A and B** over surface of R.B.C. or **antigens A and B** but **no antibodies in plasma**.
- (4) **Blood group ‘O’** : Persons with ‘O’ blood group **do not have any agglutinogen or antigens** over surface of R.B.C. but contain antibodies A and B or agglutinins A and B in plasma.

Landsteiner and Jansky not only discovered above blood groups but also demonstrated that serum antibodies of the same person do not agglutinate the antigens present in R.B.C. and this is referred as Jansky-Landsteiner law.

**Requirements** : Cavity slides, blood sample vials or small glasstubes, **antiserum-A** and **antiserum-B** and pathological binocular microscope procedure.

- Procedure** : (1) Sterilize the tip of your middle finger with sterilized cotton wet in 90% alcohol.  
 (2) Let the tip of the finger become dry.  
 (3) Prick the finger with a sterilized needle.  
 (4) Collect the blood in sample vial containing 1 ml of 0.85% sodium chloride (0.85 gms of sodium chloride powder dissolved in 100 cc. of distilled water).  
 (5) Take 2 cavity slides, each with 4 cavities wash and clean them and let the slide become dry.  
 (6) Label the cavities of the slides no. 1 and no. 2. such I, II, III and IV in no. 1 slide and V, VI, VII and VIII in no. 2 slide.  
 (7) Add a drop of 4, different samples of blood in each cavities as under

Cavities	I	—	V	—	First sample of blood
"	II	—	VI	—	Second " " "
"	III	—	VIII	—	Third " " "
"	IV	—	VIII	—	Fourth " " "

- (8) In slide no. 1 add a drop of **antiserum-A** in cavities I-IV. In slide no. 2. add a drop of **antiserum-B** in cavities V-VIII with a sterilized needle mix the blood sample and antisera gradually in each cavity slides for 10 minutes.

- Observation** : (1) I-V cavities- [No clumping hence blood group ‘O’] (First sample of blood) Agglutination  
 (2) II-VI. Clumping in II and-Blood group A second sample of blood no clumping in VI.  
 (3) III-VII. No clumping in third and-Blood group ‘B’ third sample of blood-clumping in VII.  
 (4) IV-VIII. Clumping in IV-VIII-Blood group ‘AB’ fourth sample.

**Experiment (7) Determination of Rh factor (Rhesus factor) in human blood.**

**Principle** : Rh<sup>+</sup> and Rh<sup>-</sup> agglutinogen in R.B.C. man are called as Rhesus factor. Name Rhesus factor has been derived from short sized Marnosar Rhesus macaque monkeys. If red cells of Rhesus monkey are injected into the blood of rabbit. Then it is observed that 86% R.B.C. of rabbit agglutinate showing **clumping** and 14% R.B.C. remain unaffected. The same reaction is shown by blood of Rhesus monkey

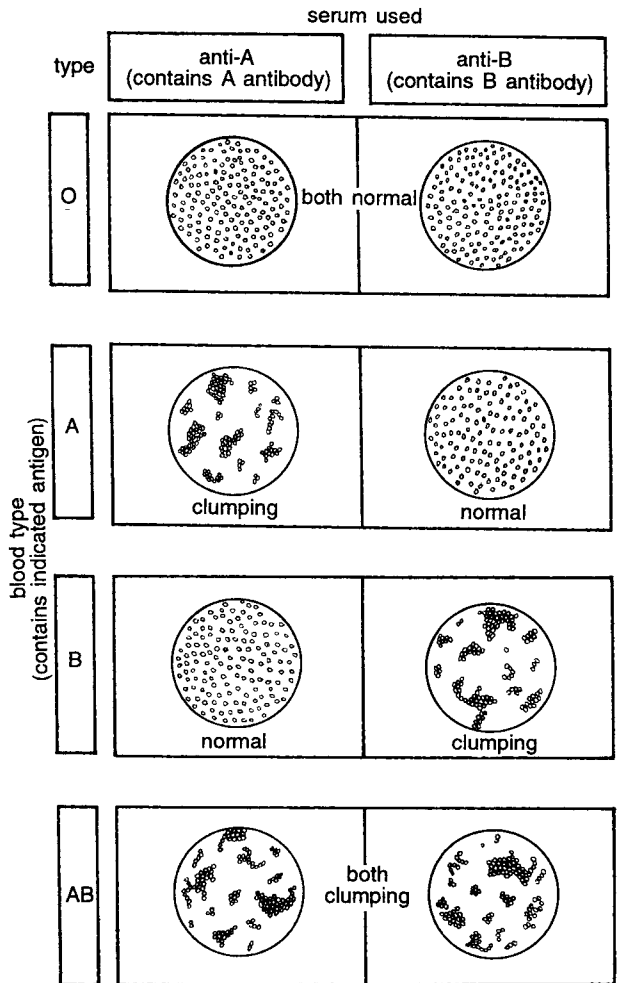

Fig. 16. Human blood groups.

and man. The agglutinating blood is called as Rh<sup>+</sup> while non-agglutinating blood is called as Rh<sup>-</sup>. When a person of Rh<sup>-</sup> blood group is frequently given transfusion of Rh<sup>+</sup> blood the farmer develops rh<sup>-</sup> agglutinins. Because of rh<sup>-</sup> agglutinins of blood group become capable to agglutinins of blood group A and B and they cause haemolysis of R.B.C. Above blood groups are hereditary. Rh factor has great medical significance during pregnancy. With Rh<sup>+</sup> father and Rh<sup>-</sup> mother foetus may be Rh<sup>+</sup>. Some R.B.C. (with Rh<sup>+</sup>) may pass into the blood of mother due to which mother develops anti-Rh<sup>-</sup> agglutinins. After the birth of first child mother becomes sensitized. In second pregnancy of sensitized mother some-of rh<sup>-</sup> red blood corpuscle would reach through placenta into the foetus. The RBC of foetus are haemolysed by sensitized R.B.C. of mother and R.B.C. of foetus are destroyed resulting into anaemia in foetus and cause death of foetus. If any rh<sup>-</sup> woman is given transfusion of Rh<sup>+</sup> blood, then woman dies. Above disease is called an **erythroblast foetalis**.

**Experiment (8) Determination of Rh<sup>+</sup> and Rh<sup>-</sup> blood groups.**

**Principle :** Because of presence of D-antigen on R.B.C. of man, blood group may be Rh<sup>+</sup>. In the absence of D-antigen blood group is Rh<sup>-</sup>. In persons R.B.C. having D-antigen is agglutinated by antibodies. Such blood is Rh<sup>+</sup>. In absence of D-antigen in R.B.C., blood is Rh<sup>-</sup>. Rh<sup>-</sup> or Rh<sup>+</sup> blood groups could be determined by 3 methods.

**[I] Slide examination method**

**Procedure :** Take a clean glass cavity slide. Add a drop of Anti-D serum is cavity and then add a drop of blood leave for 2 minutes and then observe **observation** and **result**. If agglutination occurs it

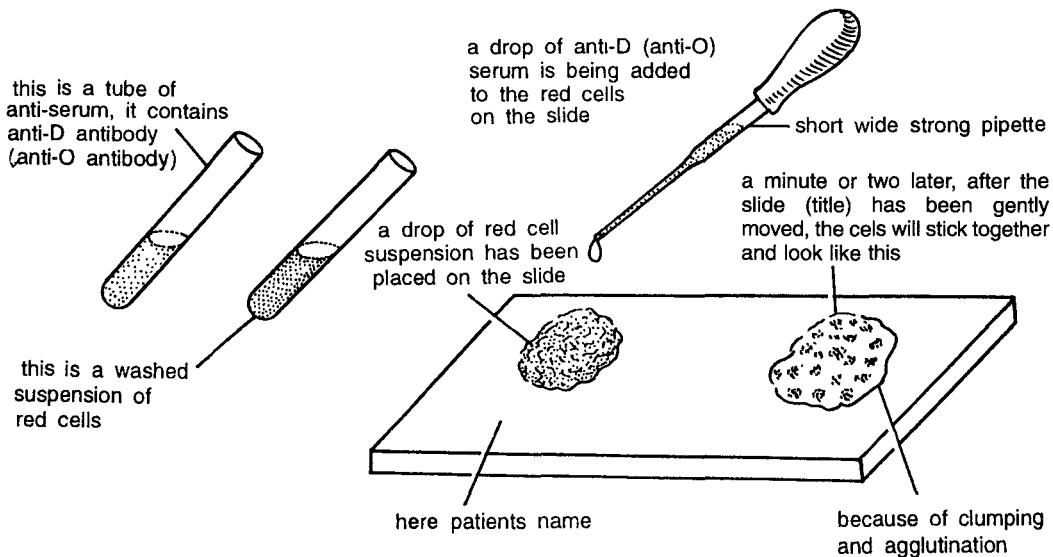

Fig. 17. Test-tube method.

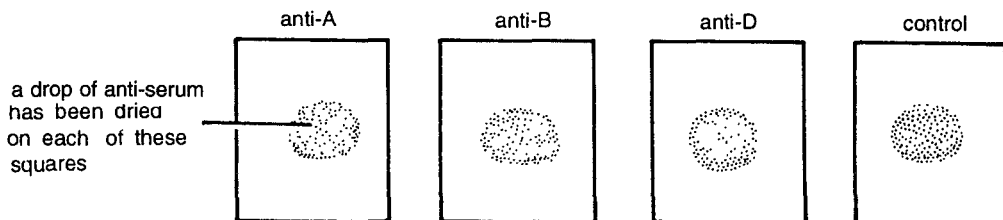

Fig. 18. Eldon card.



indicates that D-antigen in serum has resulted clumping and blood in Rh<sup>+</sup>. If no clumping blood in Rh<sup>-</sup>.

### [II] Test-tube method

**Procedure :** Take-clean test tube, pour 0.9% saline 20 ml. Add erythrocytes and make a suspension. For erythrocytes take blood, keep in centrifugation tubes and centrifuge at 3000 rpm. The erythrocytes (R.B.C.) settle at the bottom while serum is separated. Pour serum in another tube and take erythrocytes. Again centrifuge the mixture of suspension containing R.B.C. at 1000 rpm (revolution per minute).

**Observation :** If R.B.C. shows clumping or agglutination then blood in Rh<sup>+</sup> otherwise Rh<sup>-</sup>.

### [III] Eldon card method

These are small whitish cards with a square area. Take 3 cards. On one card smear with anti-A serum, on another card smear with anti-B serum and on third card smear with anti-D serum. Let the smear become dry. Before testing the blood wet the cards with distilled water and then add drop of blood in all the three square areas.

**Observation :**

**Card one :** If agglutination occurs in anti-A serum then it is blood group-A.

**Card two :** If agglutination occurs in anti-B serum, then blood group in B.

**Card three :** If agglutination occurs in anti-D serum then it is Rh<sup>+</sup> blood group.

**Experiment (9) : To demonstrate coagulation of blood.**

**Requirements :** Test tubes for blood collection, cotton wool, Aliving albino rat.

**Principle :** Blood clotting may be demonstrated in a test tube. Blood clotting or blood coagulation is a self-sealing process for cuts and injuries of blood vessels. In such injuries if no clotting occurs, then a person may go on bleeding and may die because of loss of blood.

Blood contains blood corpuscles WBC, RBC, platelets etc. In case of cuts and injuries of blood vessels, the platelets immediately release thromboplastin which converts inactive prothrombin into thrombin in presence of calcium ions. Thrombin then converts soluble plasma proteins fibrinogen into insoluble fibrin which is called as **clot**. The above process involves various enzymatic reactions and blood clotting factors.

**Procedure :** Take a clean small blood collecting glass tube. Anaesthetize a albino rat with ether. Cut abdomen and expose the heart. Collect blood from the heart through glass syringe and transfer into test-tube. Close the mouth of the tube by cotton plug. Allow the tube to stand for some time for 10 to 20 minutes. The coagulation or clot is observed in the bottom of the tube leaving a clear pale-yellow fluid called as serum.

Insert a needle in the clot to observe fibrin a thread like structure. Blood clotting may also be demonstrated on a clean slide. Sterilize the tip of your middle finger by a cotton soaked in 90% alcohol. Let the tip dry. Puncture your finger tip by a disposable sterilized needle. Collect a drop of oozing blood on a clean slide. Observe the slide. After 10 to 15 minutes clot formation occurs. Try to lift the fibrin by a needle.

**Result :** Appearance of fibrin demonstrates blood clotting.

**Experiment (10) To determine the bleeding time of blood.**

**Requirements :** Disposable sterilized pricking needle, clean slide, stop watch, filter paper.

**Procedure :** Wash your hands with detol soap. Soak the hands with a sterilized cotton towel. Clean the base tip of middle finger with a disposable sterilized pricking needle. Let the blood appear. Take a piece of filter paper. Soak the oozing blood with filter without touching the skin. As soon as blood appears start the stop watch. Let the filter paper soak the blood gradually, keep on observing. As soon as blood stops staining the filter paper, stop the stop watch. Note the time. Take three readings and then write average value. Bleeding time varies from 2 to 5 minutes.

**Result :** Time taken by the appearance of blood drop and stoppage of staining the filter paper is the clotting time.

**Experiment (11) To determine the clotting time of blood.**

**Requirements :** Water bath; sterilized disposable pricking needle, stop watch, test-tubes, glass-slides, test tube holder.

**Principle :** Same as in case of clotting of blood.

**Procedure :** Clotting time can be demonstrated from your own blood. Clean the base-tip of your middle finger by a cotton-pad soaked in 90% alcohol. Let the finger tip dry. Prick the base tip of finger by a disposable sterilized needle. Collect about 5 ml of blood in a test tube. Hold the test tube by a test-tube holder and immerse the tube in a water bath maintained at 37°C. As soon as you immerse the test-tube in water bath start the stop watch. By tilting the test tube in oblique position check the blood after every 30 seconds. In slanting or oblique position blood starts flowing in the tube. Again keep the tube in upright position after each 30 second, tilt the tube and see the blood flow. After 5 to 10 minutes blood does not flow in the tube and clotting occurs. As soon as no blood flows stop the stop watch. Note the time of stoppage of blood flow.

**Result :** From the time of pumping blood into test-tube up to the formation of clot is called as clotting time. Clot formation can be checked by piercing the needle into the clot to lift the fine threads of fibrin. Clotting can also be studied in a drop of blood on slide. Put a drop of blood on clean slide. Start the stop watch. Keep on checking the drop by a needle constantly and as soon as fibrin appears stop the stop watch. Time taken by the blood to form fibrin is called as clotting time.

**Experiment (12) To determine the blood pressure of man.**

**Concept and significance :** Word B.P. (Blood pressure) is very familiar to educated, uneducated, poor or rich people because of the fear associated with B.P. regarding the headache and hypertension. Generally older persons have to take B.P. medicines regularly.

When the blood flows through the blood vessels it exerts lateral pressure on the wall of the blood vessels and this pressure is called as **blood pressure**. Blood is pumped by the heart into blood vessels through arteries and capillaries up to the cell. Blood is collected back into the heart called as venous blood for purification. Our four-chambered heart is composed of two auricles and two ventricles.

Heart regularly beats. It contracts and then relaxes mediated by the ventricular muscles. Contraction phase is called a **systole** and relaxation phase is called as **diastole** which constitutes **cardiac cycle (S/D)**.

Significance of blood flow to maintains sufficient pressure for the flow of blood through the blood vessels. Blood pressure also provides the motive force of filtration at fine capillary beds and thus assuring regular nutrition to the tissues, cells, urine formation and proper working of lymphatic, immune and blood vascular systems. Cardiac cycle and blood pressure are regulated by myogenic regulators and neural control by neurotransmitters. Some vital organs like **heart, kidney** and **brain** have **auto regulation** for blood flow. **Stress** and **diseases** cause **changes** in blood pressure. Blood pressure is measured by a **B.P. instrument** called as **sphygmomanometer** (Fig. 19). Apparatus consists of a graduated column in millimeter (mm) in a hallow glass-tube attached to Mercury tank, a rubber-cuff connected by a tube to a rubber bulb for pumping air and a stethoscope containing ear pieces and chest or diaphragm (Fig. 20).

Blood pressure was first measured in horse by Hales : S (1733). Blood pressure in man is measured by brachial artery of the arm which supplies blood to the arm. Since the blood is pumped by heart in a rhythmic cycle hence blood pressure is highest during **systole** (contraction) and lowest at **diastole** (relaxation). Systolic pressure is called as upper limit which is **120 to 135 mm Hg**. B.P. of a healthy youngman is **120/80 mm Hg**.

Exercises and morning walk help in maintaining normal level of B.P. Emotions, excitement, diseases, food, body posture and constriction of blood vessels increase or decrease in blood pressure.

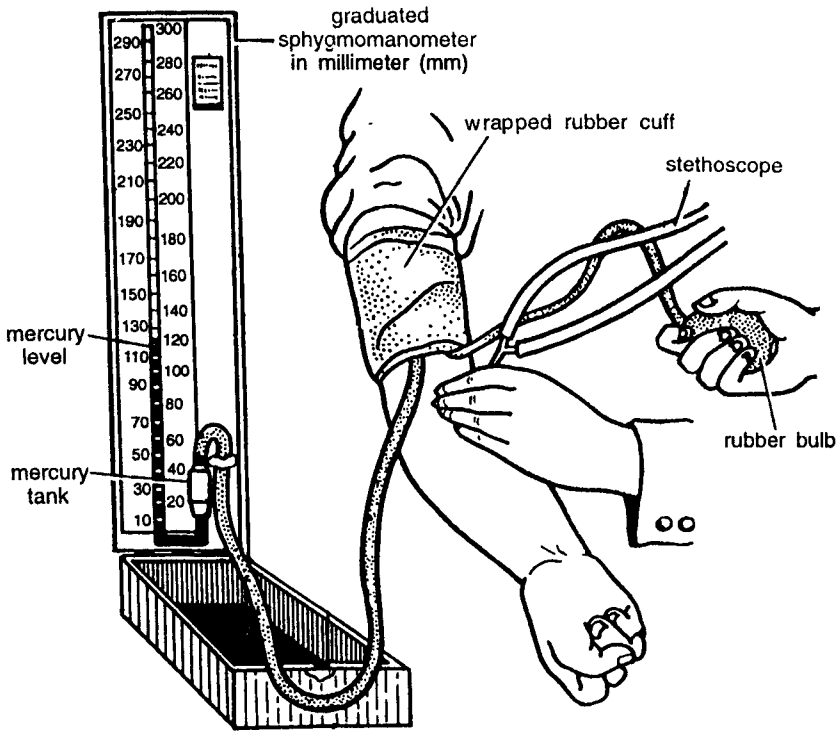

Fig. 19. Sphygmomanometer, for measuring arterial blood pressure.

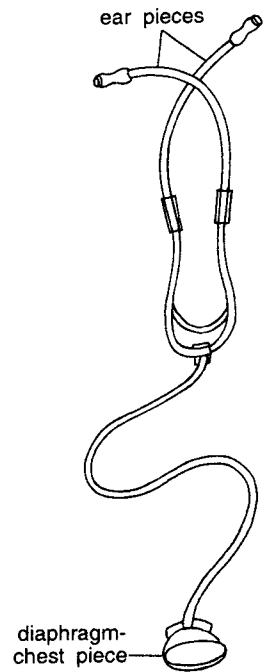

Fig. 20. Stethoscope.

**Principle of measuring B.P. :** Blood pressure is measured from **brachial artery** by mercury sphygmomanometer or by Arenoid digital monometer (Fig. 21). Blood pressure apparatus makes it possible to measure the amount of air pressure in cuff of apparatus equal to the blood pressure in brachial artery. Measurement is made in terms of how many millimeters high the air pressure raises in column of mercury in a graduated glass tube of sphygmomanometers.

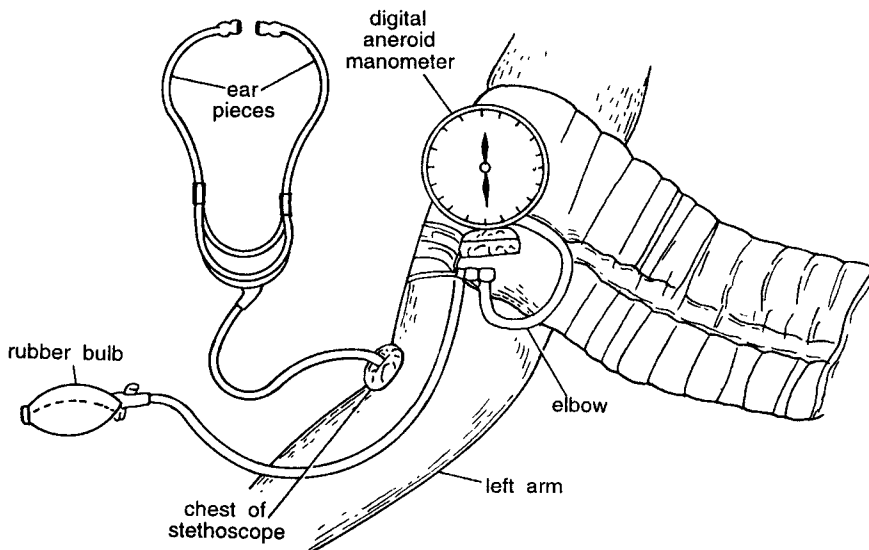

Fig. 21. Digital sphygmomanometer (Aneroid manometer).

**Procedure :** Follow the following procedure.

- (1) Person whose blood pressure is to be measured may be seated on chair by the side of a doctors table.
- (2) Stretch the left hand on the table with palm upwards. Ask the person to close the palm as shown in figure 21.
- (3) Wrap the **rubber cuff** around the arm above the elbow over the brachial artery.
- (4) Feel the pulse above the elbow and insert the chest (diaphragm) of the stethoscope just above the pulse place under rubber cuff.
- (5) Attach rubber-cuff to a compressible rubber-bulb through tube. Hold the rubber bulb in your right hand.
- (6) Compress the rubber bulb very gently and gradually to exert air pressure against outside brachial artery.
- (7) Keep on gradually pumping the air until the air pressure exceeds the blood pressure within the brachial artery or in other words starts compressing the brachial artery. At such point **no pulse** is heard through the chest of the stethoscope kept at the brachial artery above elbow along the inner margin of the picep's muscle.
- (8) Now very slowly release the air pressure in the cuff around the arm to decrease the pressure until it is approximately equal to blood pressure in the brachial artery. At this juncture small gush of blood comes out in the artery. The sudden flow of blood is marked by a sound '**dup**'. This is followed by increasing louder sound by the flow of blood in the arteries. After sometimes the sound disappears with a last sound like '**lup**' and then no sound appears. The physicians and nurses or any other person taking blood pressure must be very trained to detect above sounds '**dup**' and '**lup**' for correct measurement of the blood pressure.
- (9) It is to be kept in mind that the systolic pressure gives the important information of the force of the left ventricular contraction and diastolic (relaxation) indicates resistance of the walls of blood vessels. It also depicts the condition of peripheral blood vessels. The blood in the arteries of normal adult exerts a pressure equal to that required to raise a column of mercury approximately 120 mm high in a glass tube during systole of ventricles and 80 mm during diastole of ventricles. During systole of ventricles mercury column in **40 mm Hg** higher than diastole and this denotes pulse pressure (PP) which depicts difference between **SBP** and **DBF** *i.e.*,  $120-80 = 40$ . The SBP (systolic) blood pressure minus DBP (diastolic blood pressure) is clinically expressed as SBP/DBP *i.e.*, 120/80.
- (10) After taking blood pressure unwrap the cuff and close the B.P. apparatus.
- (11) In case rise of systolic blood pressure than 120 mm Hg or decrease of diastolic blood pressure or increase of diastolic blood pressure consult the physicians for advice and consequent treatment. By treatment and precautions blood pressure becomes normal.

**Precautions for taking blood pressure :** Check the B.P. instrument regularly for any leakage in air pressure in cuff or rubber bulb.

- (1) While taking blood pressure, the palm of the patient should always be upwards.
- (2) Brachial artery above the elbow should be palpated correctly before placing the chest of the stethoscope over the angle of the elbow.

## Experiments of Urine Using Human Urine Sample

**Experiment (13) To determine urea in human urine sample.**

**Requirements :** (i) Test tube, (ii) Phenolphthalein solution, (iii) Urine sample, (iv) Urease enzyme.

**Procedure :** For urine sample patients should be told to bring first urine passed in the morning. Urine must be collected in sterilized **urine sample bottle** supplied by pathologists.

Take a clean tube. Through dropper add 5 ml of urine from sample urine bottle. Measure 5 ml of urine in a 10 cc measuring cylinder. Add few drops of phenolphthalein solution in the test tube. Solution becomes milky, then add few drops of urease. Milky solution turns red.

**Result :** Red colour in test-tube shows presence of urea.

**Experiment (14) Test for Blood-cells in the human urine.**

**Requirement :** Benzidine saturated solution. Hydrogen peroxide acid test tube.

**Procedure :** Collect urine sample as above. Take a clean test tube and add 3 ml of saturated solution of benzidine, then add 2 ml of urine and 1 ml of 3% hydrogen peroxide.

**Observation :** Appearance of blue or green colour indicates presence of blood cells in urine. Haemoglobin of R.B.C. reacts with  $H_2O_2$  (hydroperoxide) and liberates  $O_2$  (oxygen). This oxygen oxygenates benzidine due to which colour becomes blue or green.

**Result :** Appearance of blue or green colour indicates presence of R.B.C. in urine.

**Experiment (15) To detect bile salts in urine.**

**Requirements :** Sulphur, test tube, distilled water, urine sample, sugar, sulphuric acid, bile salts in urine can be detected by following 2 methods little.

**[I] Hay's test**

**Procedure :** Take a clean test tube, add 5 ml of urine from sample bottle. Add little amount of sulphur over the surface of urine. In another test take 5 ml of distilled water and add little amount of sulphur over surface of water.

**Observation :** After sometimes sulphur sinks to bottom of the urine tube. Bile salts reduce the surface tension of urine and hence sulphur sinks. In distilled water tube sulphur remains at the surface of water.

**Result :** Sinking of sulphur in urine tube shows presence of bile salts in urine.

**[II] Pattern Roffoo's test**

**Procedure :** Take 2 ml of urine from sample bottle through pipette. Add little sugar, mix and warm. Then very carefully and gently add  $H_2SO_4$  (Sulphuric acid) by the side of inner wall of the test tube.

**Observation :** Deep red colour is seen.

**Result :** Emergence of deep red colour shows presence of bile salts in urine.

**Experiment (16) Test for albumin in human urine.**

**Requirements :** Test tube, 100 cc beaker, ammonium sulphate, sodium nitropruside and ammonium solution.

**Procedure :** Collect urine is urine sample in sample bottle. Take 20 cc of urine in a clean test-tube from sample bottle. Warm the urine. If turbidity appears it indicates presence of albumin. On heating albumin coagulates showing turbidity. Add 3 to 4 drops of acetic acid. Urine becomes turbid.

**Result :** Appearance of turbidity indicates albumin.

**Experiment (17) To detect ketone bodies in human urine.**

**Procedure :** Take little urine in then tube from sample bottle. Add little ammonium sulphate to make saturated solution. Mix few drops of ammonium solution and then add fine crystals of sodium nitrosopruside. Reddish orange colour appears.

**Result :** Appearance of reddish orange colour indicates presence of ketone bodies.

**Experiment (18) Test for sugar in human urine.**

In the beginning of this chapter see Fehling's test, Benedict's test, Nylander's test and Rapid for furfural test for sugars.

**Experiment (19) To demonstrate oxygen consumption of albino-rat or black rat (*Rattus rattus*).**

**Requirements :** Haldane's apparatus consisting of aspirator, manometer, gas meter, I-V glass chambers and a rat chamber, Punic stone, Sulphuric acid and NaOH (soda lime) solution, all the above chambers connected by U-tubes. Experimental animal may be Albino rat or black rat. The aspirator draws air through all the chambers. Manometer consists of a inverted bell for kept over a water which prevents an excess of negative pressure and it also depicts the pressure employed. Chambers I and IV are filled with water lime in soda lime which absorbs carbon dioxide of the air. Chambers II, III and V contains punic stone and sulphuric acid which absorb moisture of the air (Fig. 22).

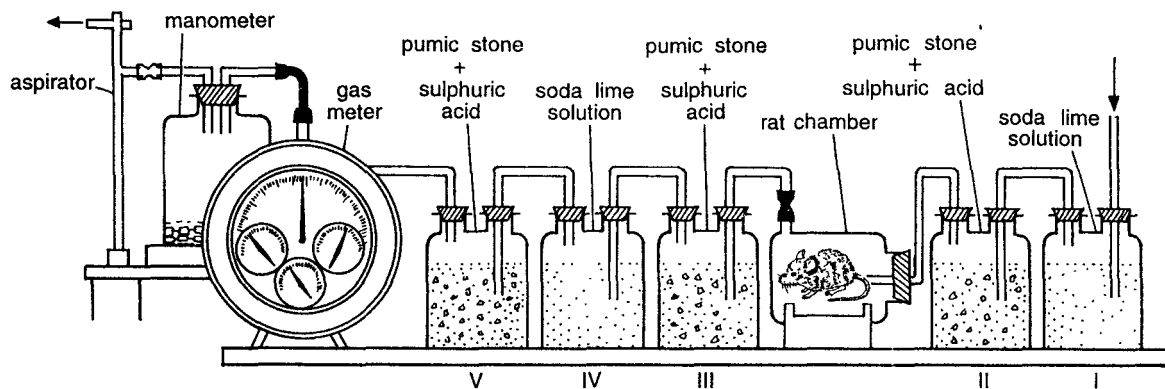

Fig. 22. Haldane apparatus showing oxygen consumption by rat.

**Procedure :** After setting the above apparatus keep the experimental rat in rat chamber. Before starting the experiments weigh all the chambers. Draw air through the aspirator. When the air enters chamber-I, the CO<sub>2</sub> is absorbed by soda lime, then air entering chamber-II, moisture is absorbed. Now air enters rat chamber. Rat utilizes the oxygen for its respiration. Then rat exhale's CO<sub>2</sub> which enters chamber-III which absorbs moisture and then chamber-IV absorbs CO<sub>2</sub> and again chamber-V absorbs moisture. Draw the air for a specific period and then stop drawing air and weight all the chambers including experimental rat chamber.

**Result :** Increase in weight during specific period of time depicts the amount of oxygen consumed during that period.

**Experiment (20) To determine the rate of oxygen consumption of a Albino rat or black rat.**

**Requirements :** 1000 cc wide mouth 2 glass stoppered bottles A and B. Connect the two bottles with U-shaped glass tubes as shown in (Fig. 23). Glass-bottle B fit a U-shaped graduated glass-tube on the side. Fill one fourth glass jar B with 10% KOH solution (10 gm of KOH pellets dissolved in 100 cc of distilled water, Fig. 23-A).

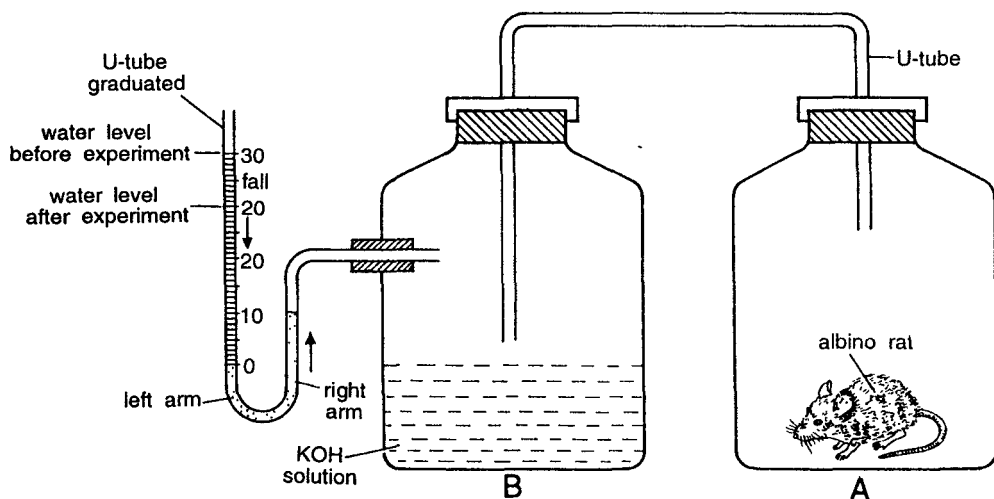

Fig. 23. Apparatus demonstrating rate of oxygen consumption.

**Procedure :** Set the above apparatus on the table. Fill the side-graduated glass tube with 30 cc of water.

Note the level of water in the left graduated tube. Now keep a living 120 gm Albino rat in jar A.

Close the mouth of both jars A and B with stopper tightly. Apply vasline on inner side of the stopper to make it air tight. Keep the rat for 1 hour.

**Observation :** After 1 hour the level of water in the right arm of the tube rise. In left arm of the tube the level of water falls from 30 to 20. Rat consumers oxygen of jar A and B and release CO<sub>2</sub> (carbon dioxide) which is observed by KOH. Air pressure is reduced in the bottle hence water level falls in left arm of the tube. It can be calculated as under :

- |  |         |
|--|---------|
| (1) Water level just after closing the jar       | = 30 cc |
| (2) Water level after one hour                   | = 20 cc |
| (3) Fall of water level in the tube after 1 hour | = 10 cc |

**Result :** Rate of oxygen consumption after 1 hour is = 10 cc

#### **Experiment (21) To demonstrate osmosis.**

**Principle :** Osmosis is a kind of diffusion process in which water or any solvent diffuses through semipermeable membrane from lower concentrations solute solvent to higher concentrated solute solution. Movement of solvent induces change in volume but movement of solute has no effect.

**Requirements :** For studying osmosis 200 cc borosil glass beaker, a thistle funnel, concentrated saturated sugar solution (take 100 ml of distilled water and keep on adding sugar crystals till some sugar remains undissolved), a cellophane paper (as semipermeable membrane), glass marking pencil and a stand are required.

**Procedure :** Set up experiment as shown in figure 20. Take 200 cc glass beaker wash it first powder. Then tape water and rinse with distilled water. Tie the mouth of thistle funnel with a cellophane paper. Suspend thistle funnel by the neck as shown in figure 20 through a stand inside the beaker leaving sufficient space between mouth of thistle funnel and bottom of the beaker. Now fill the beaker with distilled water around thistle funnel up to certain level as shown in figure. Immediately also fill the thistle funnel up to the level shown in figure. Start the stop water or note the time and leave the experiment for 1 hour. Mark the water levels in beaker and inside the neck of the funnel with glass marking pencil (Fig. 24 A, B).

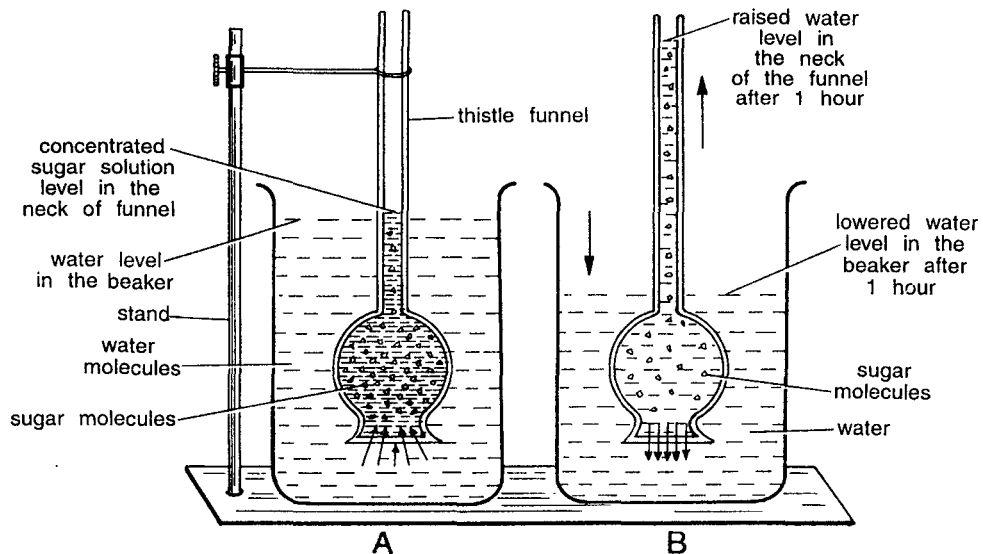

Fig. 24. Osmosis experiment. A. At the beginning, B. Same after 1 hour.

**Observation :** After 1 hour observe water in the neck of the thistle funnel and of the beaker-mark it with glass marking paper. It is observed that water level in the neck of the funnel rises because the water from the beaker with low concentration diffuses into the thistle funnel having much higher concentration of glucose through the semipermeable membrane. Concentrated sugar solution can not move into neck of the thistle funnel because the cellophane paper does not permit movement of sugar solution into the beaker.

**Result :** Above experiment demonstrates the process of osmosis.

**Experiment (22) To demonstrate neurons by methylene blue in nerve fibers and nerve cells from the sciatic nerve or spinal cord of frog.**

**Requirements :** Living frog, slide, coverslip, brush, petridish, forceps, scissors, needles and 1% methylene blue solution (dissolve in 100 cc of distilled water).

**Procedure :** Nerves can be demonstrated from spinal cord of frog in a temporary glycerine preparation (mounting).

Take a small size living frog, anaesthetize it and fix it on the dissecting tray. Cut the flap of skin over the skull. Expose spinal cord. Take a small piece of nerve tissues from the centre of spinal cord with help of scissor and forcep and keep the tissues on a slide. Tease the nerve fibers under stereoscopic microscope. Transfer the teased tissue in a petridish by a brush or needle. Add few drops of NaCl solution over the teased tissue, then pour few drops of 1% methylene blue in petridish for staining for 5 minutes. Transfer the nerve tissues on a slide with the help of a brush or needle. Tease the stained nerve fibres with the needle till the fibres are well separated. Soak (blot) the excess of stains with blotting paper. Add a drop of glycerine over the tissue and mount by a coverslip. Press the slide a little to spread nerve cells. Examine neurons under a microscope.

**Observation :** (1) Neurons are cyton are observed as large bodies having distinct **nucleus**.

(2) Neurons also reveal cytoplasmic projections as dendrites. Long dendrite is called as axon.

(3) Presence of myelin sheath over axon shows that it is a myelinated nerve fibre. At node of Ranvier myelin sheath is absent. Draw the nerve cells and axon on the practical exercise paper.

**Precautions :** Hold the slide by the edge between 2 fingers. Always observe the nerve. Keep the cover slip very gently. Soak excess of glycerine by filter paper around the coverslip.



# 13

## Some Important Histochemical Tests

Recently, histochemistry has emerged as one of the most important aspects of research, being applicable to medical, veterinary, academic and agricultural sciences. Histochemistry demonstrates chemical constituents of tissues as well as cells. Different tests are applied for the study of different constituents. Such as the techniques described here have been followed after Pearse, 1968, with slight modifications wherever needed.

### GLYCOGEN

Glycogen is a reserve food present in muscles, liver and organs, tissues and cells. Two important techniques, namely : (1) **PAS (periodic acid-schiff)** and (2) **Best carmine staining** are applied.

#### 1. PAS (Periodic Acid Schiff) Technique

Periodic acid Schiff's reaction is normally referred to as PAS. The entire modern histochemistry is bound up with the periodic acid Schiff's reaction, and it is therefore necessary to consider at this point the principles on which this reaction is based (Pearse, 1968).

Periodic acid is an oxidizing agent which breaks the C-C bonds of polysaccharides, converting them into dialdehydes. These dialdehydes further react with Schiff's reagent giving purplish red colour. The union of fuchsin-sulphurous acid with aldehydes forms a new compound in the form of red dyestuff.

#### [I] Preparations of solutions

- (1) **Periodic acid.** Dissolve 0.4 gm powder of periodic acid in 35 cc of ethyl alcohol and add 5 cc of 0.2 M\* sodium acetate (27.2 gm of the hydrated sodium acetate in 1,000 cc of distilled water) and 10 cc of distilled water. (\* M=Molar solution).

The above solution should be kept in dark at a temperature of 17°C to 22°C. The above solution should be discarded if a brown colour develops, and the solution should be prepared fresh.

- (2) **Reducing bath.** Dissolve 1 gm of potassium iodide and 1 gm of sodium thiosulphate in 30 cc of ethyl alcohol and 20 cc of distilled water. Add 0.5 cc of 2 N-HCl (20% conc. HCl). A deposit of sulphur is formed which can be ignored. Keep the solution between 17°C to 22°C. The solution lasts for 14 days only and after this period, prepare fresh solution.
- (3) **Schiff's reagent.** Dissolve 1 gm of basic fuchsin in 400 cc of boiling distilled water. Cool to 50°C and filter. To the filtrate add 1 cc of thionyl chloride. Let the solution stand for 12 hours in dark. Clear by shaking for 1 minute with 2 gm of activated animal charcoal. Filter and store in dark at 0°C to 4°C. Use this solution in dark at room temperature.
- (4) **Celestin blue solution.** Dissolve 2.5 gm iron alum in 50 cc of distilled water by standing overnight at room temperature. Add 0.25 gm of celestin blue B and boil for 3 minutes. Filter when cool and add 7 cc of glycerol.
- (5) **Orange G solution.** Dissolve 2 gm orange G in 100 cc of 5% aqueous phosphotungstic acid. Allow to stand for 24 hours and use the supernatant.

### [II] Preparation of sections

For demonstrating glycogen fix the tissue (liver or muscle) in Gendre fluid consisting of (i) saturated alcoholic picric acid 85 parts, (ii) 40% formaldehyde 10 parts, and (iii) glacial acetic acid 5 parts. Follow the microtomy procedures and cut the sections.

### [III] PAS staining method (after McManus)

- (1) Bring sections to distilled water → through xylol → 100% alcohol → 90% alcohol → 70% alcohol → 50% alcohol → 30% alcohol – distilled water.
- (2) Oxidize for 10 minutes in 1% aqueous periodic acid.
- (3) Wash in running water for 5 minutes.
- (4) Immerse in Schiff's reagent for 10 minutes.
- (5) Wash in running water for 5 minutes.
- (6) Counterstain nuclei with celestin blue haemalum sequence if required.
- (7) Differentiate if necessary in 1% acid alcohol and follow by thorough washing in running water.
- (8) Dehydrate in alcohol, clear in xylol and mount in suitable synthetic medium (DPX or Canada balsam).

**Observation :** Hexose containing mucosubstances stain in various shades of purplish red. Presence of **glycogen** in tissues is indicated by a deep purple colour.

## 2. Carmine Staining Technique (After Best, 1906)

For above staining the best fixative for glycogen is ice-cold picro-alcohol formalin.

### [I] Preparation of solutions

- (1) **Carmine stock solution.** Add 2 gm carmine, 1 gm potassium carbonate and 5 gm of potassium chloride to 60 cc of distilled water. Boil gently for 5 minutes, cool and filter. Add to the filtrate 20% cc of ammonia. This solution lasts 3 months at 0°C to 4°C.
- (2) **Carmine staining solution.** Dilute 15 cc of stock solution with 12.5 cc of ammonia and 12.5 cc of methyl alcohol. This solution lasts for 2 to 3 weeks.
- (3) **Best's differentiator**

100% alcohol	8 cc
Methyl alcohol	4 cc
Distilled water	10 cc

**[II] Staining method**

- (1) Bring sections to absolute alcohol.
- (2) Place sections in 1% celloidin in absolute alcohol or ether for 2 minutes.
- (3) Dry in air.
- (4) Pass through alcohol to tap water.
- (5) Stain in Ehrlich's haemalum for 5 minutes.
- (6) Rinse and differentiate rapidly in 1% acid alcohol.
- (7) Rinse in water.
- (8) Stain in best carmine solution for 15 to 30 minutes.
- (9) Differentiate in Best's differentiator, for 5 to 60 seconds.
- (10) Wash in 80% alcohol.
- (11) Dehydrate in absolute alcohol, clear in xylene and mount in DPX or Canada balsam.

**Observation :** Glycogen stains red and nuclei dark blue in the mounted sections.

## LIPIDS

Lipids are also major component of reserve food, found associated with proteins or other substances. Lipids provide energy and have structural importance being associated with membrane system. Lipids may be phospholipids, glycolipids, lipoproteins or derived lipids. Lipids can be demonstrated in tissues in paraffin sections. Specially for the staining of phospholipids, by fat-soluble dye techniques, alcoholic Sudan Black-B is used. The dye reacts with lipids giving black colour.

### Sudan Black-B Staining for Lipids in Paraffin Sections (After McManus, 1946)

**[I] Preparation of sections**

Fix the tissue for 1 to 5 weeks in a solution of 1 gm of cobalt nitrate in 80 cc of distilled water with 10 cc of 10% calcium chloride and 10 cc of commercial formaline (40%). The formalin preserves lipid portion in tissues. For achieving better results, McManus has also recommended treatment of the sections (post-chroming) for 24 to 28 hours in 3%  $K_2Cr_2O_7$  (potassium dichromate). Dehydrate the tissue in acetone for one and a half hours with 3 changes. Place the tissue directly in molten paraffin for embedding. Prepare the blocks and cut the sections as usual.

**[II] Staining method**

- (1) Bring sections in 70% alcohol.
- (2) Stain for 30 minutes at room temperature in saturated Sudan black-B in 70% alcohol.
- (3) Remove excess dye by rinsing quickly in 70% alcohol.
- (4) Wash in running water.
- (5) Counterstain in Mayer's carmalum for 16 hours or in 1% aqueous neutral red for 1 minute.
- (6) Wash in water and mount in DPX or glycerine jelly.

**Observation :** Lipids stain black in the section.

## PROTEINS

The proteins form the bulk of the biological tissues. They may be (i) **Simple proteins** like albumins, globulins, protamines and histones; or (ii) **Conjugated proteins** like nucleoproteins, mucoproteins, glycoproteins, lipoproteins and phosphoproteins. Proteins can be demonstrated in paraffin sections by the following method.

### Mercury-Bromophenol Blue Method for Proteins (After Bonhag)

- (1) **Sections.** For proteins fix the tissues in carnoy or formalin. Cut paraffin sections as usual.
- (2) **Preparation of staining solution.** 1% HgCl<sub>2</sub> and 0.05% bromophenol blue in 2% aqueous acetic acid.
- (3) **Staining method.** (i) Bring paraffin sections to water, (ii) Stain in the above staining solution for 2 hours at room temperature. (iii) Rinse sections for 5 minutes in 0.5% acetic acid. (iv) Transfer sections directly into tertiary butyl alcohol. (v) Clear in xylol and mount in DPX.

**Observation :** Deep blue colour in sections shows presence of **proteins**.

## ACID AND ALKALINE PHOSPHATASES

The enzymes phosphatases hydrolyzing esters of phosphoric acid, are widely distributed and play an important role in many metabolic processes. They can be divided into 3 classes :

- (1) Pyrophosphatases (ATPases -Adenosine triphosphatases),
- (2) Phosphomonoesterases, and
- (3) Phosphodiesterases.

These phosphatases working in acid medium are called **acid phosphatases** and working in alkaline medium are called **alkaline phosphatases**. Both the acid and alkaline phosphatases can be demonstrated in sections.

### 1. Acid Phosphatase : The Lead Nitrate Method (After Gomori, 1950)

- (1) **Preparation of sections.** Fix the material in cold acetone and cut the paraffin sections as usual.
- (2) **Staining method.** (i) Bring sections to water. (ii) Incubate at 37°C for 15 minutes to 4 hours depending upon the reaction, in freshly prepared 0.01 M. sodium ( $\beta$ -glycerophosphate in 0.05 M. acetate buffer (pH - 5.0) containing 0.004 M. lead nitrate. (iii) Wash briefly and immerse in dilute yellow ammonium sulphide for 1 to 2 minutes. (iv) Wash the sections in water. (v) Mount directly in DPX. Dehydration is not needed.

**Observation :** The presence of acid phosphatase in sections is indicated by a black precipitate of lead sulphide.

### 2. Alkaline Phosphatase Method (After Fredricson, 1956)

- (1) **Preparation of sections.** (i) Fix small blocks of tissue in 90% alcohol for 24 hours at 22°C (two changes). (ii) Transfer to 96% alcohol for 1 hour. (iii) Transfer to absolute alcohol (two changes 15 minutes each). (iv) Transfer to benzene (two changes, 30 minutes each). (v) Embed in paraffin wax at 56°C. (vi) Cut sections as usual, 3 to 10 microns thick.

(2) **Staining method.** (i) Remove wax with xylene and pass first through absolute acetone and then 40% acetone to water.

(ii) Incubate for 10-60 minutes in a closed couplin jar at 37°C in the following mixture :

2% Sodium ( $\beta$ -glycerophosphate	25 cc
2" Sodium verhol	25 cc
2" Calcium nitrate	5 cc
0.8% Magnesium chloride	5 cc
Acetone	40 cc

(iii) Rinse in 40% acetone. (iv) Treat with 2% cobalt nitrate in 40% acetone for 5 minutes. (v) Rinse in 40% acetone. (vi) Treat with dilute yellow ammonium sulphide in 40% for 3 minutes (vii) Rinse in absolute acetone, and dehydrate in alcoholic grades as usual. (viii) Clear in xylol and mount in DPX.

**Observation :** Clear black deposits of cobalt sulphide indicate sites of enzyme activity (presence of alkaline phosphatase).

# Experimental Cytology

# 14

This chapter includes the study of :

- (1) **Prokaryotic and Eukaryotic cells.**
- (2) Preparation of chromosomes in **mitosis** and **meiosis** from plant and animal materials.
- (3) Study of mitosis from prepared slides.
- (4) Study of meiosis from prepared slides.
- (5) Demonstration of mitochondria by supra-vital stains.
- (6) Study of ultrastructure of different cell organelles (Mitochondria, Endoplasmic reticulum, Golgi body, Chloroplast and Nucleus) by their microphotographs.

## 1. Prokaryotic and Eukaryotic Cells

Prokaryotic cells are primitive while Eukaryotic are advanced cells.

Differences between Prokaryotic and Eukaryotic cells alongwith examples are given in Table 1.

### [I] *Mycoplasma* cells

- Comments :** (1) *Mycoplasma gallisepticum* is the smallest living cell found in sewage and soil.  
 (2) Cells rounded measuring 0.1 to 0.5  $\mu\text{m}$ .  
 (3) Cell wall thick and made up of phospholipid protein layer.

**Table 1.**

Characters	Prokaryotic cell	Eukaryotic cell
1. Cell wall	Present and composed of amino sugars and muramic acid	Absent in animal cells. Present in plant cell and contains cellulose.
2. Plasma membrane	Present	Present
3. Nucleus and nuclear membrane	Absent	Present
4. Endoplasmic reticulum (E.R.)	Absent	Present
5. Golgi body	Absent	Present
6. Lysosomes	Absent	Present
7. Mitochondria	Absent	Present
8. Nucleolus	Absent	Present
9. Genetic material	DNA or RNA	DNA
Examples :	1. <i>Mycoplasma</i> cells 2. <i>Escherichia coli</i> cells 3. Blue green algal cells	1. Generalized yeast cell 2. Generalized plant cell 3. Generalized animal cell

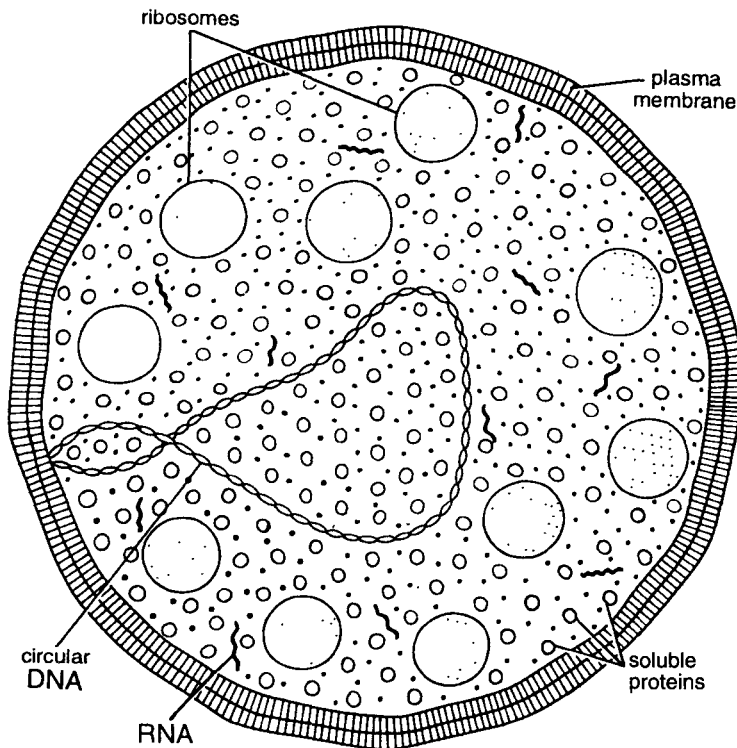

Fig. 1. *Mycoplasma* cell.

- (4) Ribosomes large spherical bodies. Soluble proteins rounded small bodies.
- (5) DNA distinct, twisted or looped and double helical.
- (6) These organisms originated three billion years ago.

**Identification** : Since the above cell is smallest and contains spherical bodies and twisted DNA, hence it is *Mycoplasma* cell (Fig. 1).

### [II] *Escherichia coli*

- Comments** :
- (1) Most extensively studied prokaryotic cells.
  - (2) Rectangular or rod-shaped measuring  $2\ \mu\text{m}$  in length and  $0.5\ \mu\text{m}$  in thickness.
  - (3) Cell wall rigid composed of proteins, polysaccharides and lipid molecules.
  - (4) Beneath cell wall is plasma membrane made up of lipoproteins. Plasma membrane contains respiratory chain enzyme system.

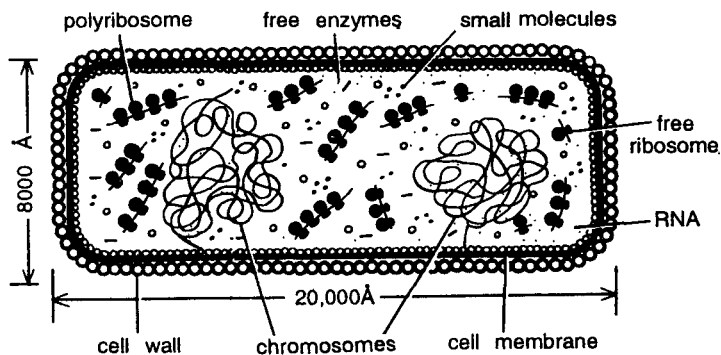

Fig. 2. *Escherichia coli*.

(5) DNA is circular and coiled. Free ribosomes, polyribosomes and RNA are also seen.

**Special features :** *Escherichia coli* constitute our intestinal flora. They are non-pathogenic symbiotic bacteria found in the intestine of man. The colony of *E. coli* should not be confused with *Entamoeba coli* which is a protozoan. It could be cultured in agar plates. *Escherichia coli* have been extensively used in molecular biological studies.

**Identification :** Since the above cell contains cell wall, plasma membrane and circular DNA, hence it is *E. coli* cell (Fig. 2).

**[III] Blue green algal cell**

- Comments :** (1) Body rounded in shape.  
 (2) Resemble bacterial cells in many respects.  
 (3) Outer covering is a gelatinous sheath called cell wall.  
 (4) Beneath cell wall is plasma membrane composed of lipoprotein, mucoprotein and lipopolysaccharide.  
 (5) DNA is circular and double helical.  
 (6) These algal cells contain photosynthetic pigments such as chlorophyll and carotenoids.

**Identification :** Since the above cell contains cell wall, plasma membrane and chlorophyll, hence it is blue green algal cell (Fig. 3).

**[IV] Generalized plant cell**

- Comments :** (1) Shape varies.  
 (2) Cell wall thick contain cellulose.  
 (3) Nucleus, nucleolus, endoplasmic reticulum, mitochondria and ribosomes present.

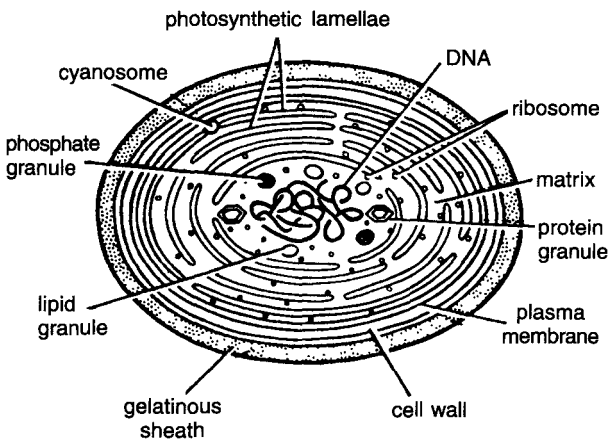

Fig. 3. Blue green alga.

- (4) **Plastids present.**  
 (5) Different kinds of plant cells are **parenchyma, collenchyma, sclerenchyma, xylem and phloem.**

**Identification :** Since the above cell contains thick cell wall and plastids, hence it is a plant cell (Fig. 4).

**[V] Generalized animal cell**

- Comments :** (1) Cell wall of cellulose absent.  
 (2) Outer covering is **plasma membrane** which at certain places is differentiated into **desmosomes, microvilli or basal membrane.**  
 (3) Nucleus contains nucleolus and chromatin or chromosomes having DNA.  
 (4) Cytoplasm contains **endoplasmic reticulum, mitochondria, ribosomes, Golgi bodies and lysosomes.**  
 (5) Pinocytotic vesicles and secretory vesicles are seen.  
 (6) Different kinds of animal cells are epithelial ciliated, squamous, cuboidal columnar epithelial, flagellated (choanocytes) mesenchyma flame cells, striated muscle cells, simple muscle cells, nerve cells, blood cells (RBC, WBC, platelets), lymphocytes, plasma cells, osteocyte cells, and cancer cells.

**Identification :** Since cell contains plasma membrane, above features, and no cell wall, hence it is an animal cell (Fig. 5).

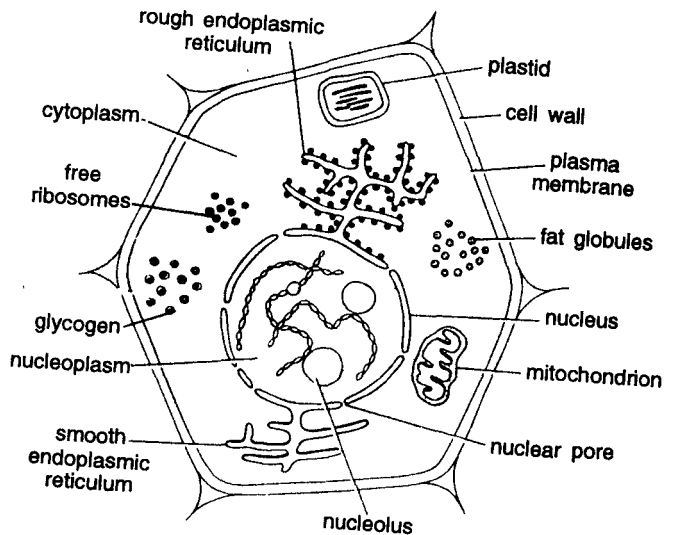

Fig. 4. Plant cell.



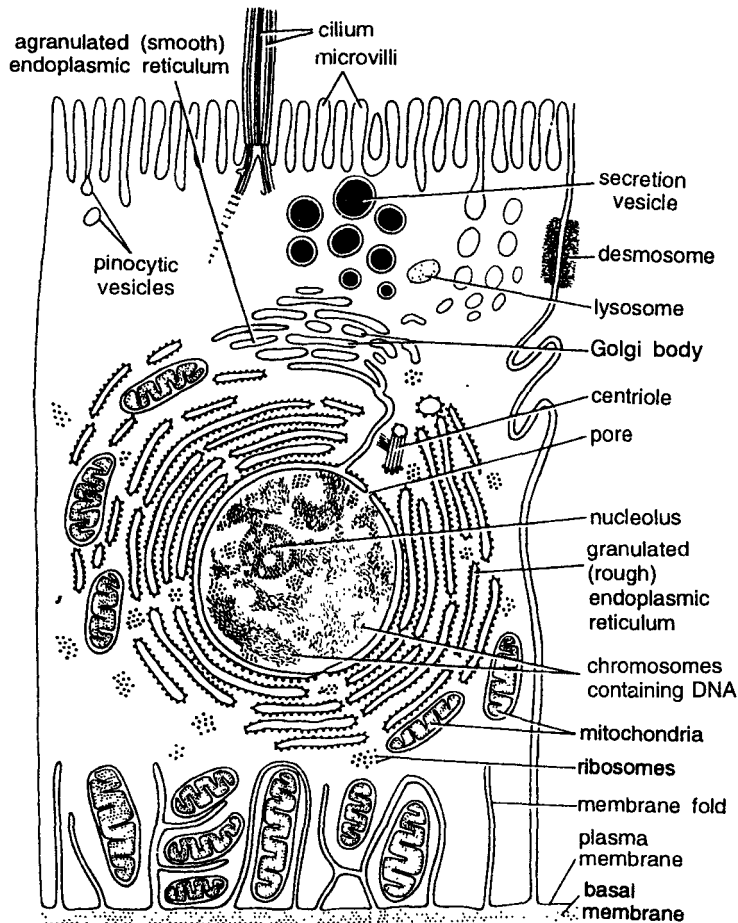

Fig. 5. Generalized animal cell.

## 2. Preparation of Chromosomes

**Introduction :** Chromosomes can be prepared from the following plant and animal materials :

- (1) Onion root tips for **mitosis** in plants.
- (2) Anthers from **Bajra** or other plants for **meiosis**.
- (3) Testis from animals for **mitosis** and **meiosis**.
- (4) Salivary gland chromosomes (giant chromosomes) from larvae of *Chironomus* and *Drosophila*.

**Technique :** Chromosomes can be prepared by **squash technique** and **heat dry Giemsa method**. Carnoy's fluid is used as a fixative. (1 cc glacial acetic acid; 3 cc chloroform and 6 cc absolute alcohol). Acetocarmine or Giemsa are used as stains.

(Z-21)

### [I] Chromosomes from onion root tips for mitosis by squash method

**Material :** Take a few onion bulbs. Place them in a tray containing moist soil with dried roots facing soil. After 4 or 5 days new roots would appear. Take out onions and wash them. Cut 2 to 3 cm root tips and fix them directly in specimen tubes having Carnoy's fluid.

**Method :** Take one or two preserved root tips on a slide with acetocarmine stain. Place a coverslip over them and tap it gently with a needle or pencil. Warm it tightly over the flame of a spirit lamp. Now put a piece of blotting paper on coverslip and apply a uniform pressure by your thumb.

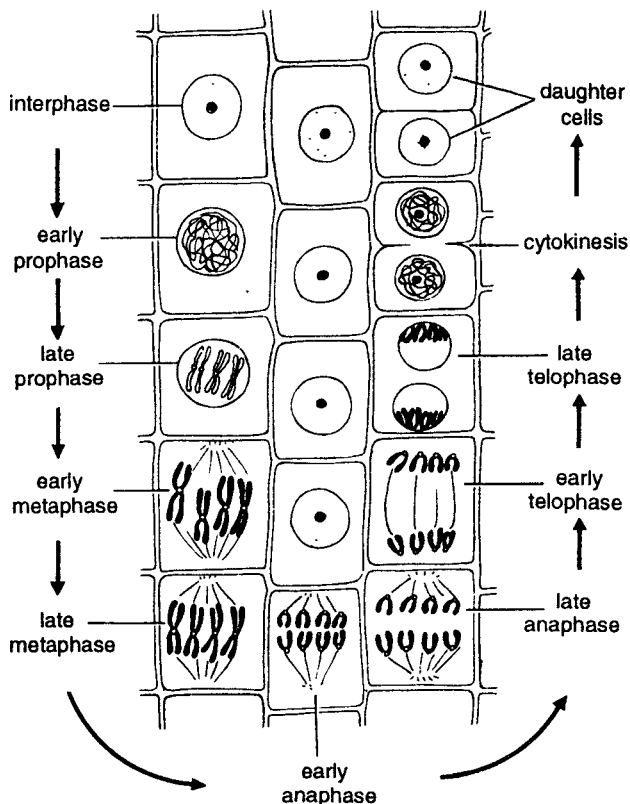

Fig. 6. Different mitotic stages. Onion root tip.

Another method can also be applied. From Carnoy's fluid, transfer all the root tips in a small conical flask containing acetocarmine. Boil the material and apply squash technique as above.

**Observation :** Examine the slide under the microscope. The cells and their chromosomes become spread out and distinct. Search out for different **early** and **late** mitotic stages such as **interphase prophase, metaphase, anaphase, telophase** and **cytokinesis**. Study and draw such stages (Fig. 6) in your practical copy and write comments with the help of practical book.

**[III] Chromosomes from pollen mother cells (anthers) for meiosis by squash method**

**Procedure :** For above purpose anthers of **Bajra** plants can be taken in early crop season. Fix anthers in Carnoy's fluid and prepare slide by **squash method** as described in case of onion

root tips. Study various meiotic stages such as **Leptotene, Zygotene, Pachytene, Diplotene** and **Diakinesis** of first prophase, first metaphase, first anaphase, first telophase and second meiotic divisions.

**[III] Study of chromosomes, both for mitosis and meiosis stages from testis of frog, grasshopper, cricket, *Gryllus* and nematodes (*Ascaris, Setaria, hookworms*)**

**1. Squash method.**

**Procedure :** (1) Collect grasshoppers from the green fields or crickets from stores in houses.  
 (2) Anesthetize them with chloroform.  
 (3) Dissect the male insect in a dissecting dish having normal saline (0.78% NaCl).  
 (4) Remove testes and fix them in Carnoy's fluid for 2 to 12 hours.  
 (5) Stain testis lobes in acetocarmine.  
 (6) Take testis lobes (stained) over a slide, and cover with a coverslip. Apply squash method (heat, tap and press) as mentioned for onion root tips.

**2. Heat dry Giemsa method for making permanent slide.**

**Procedure :** (1) Take out testes from a grasshopper or nematode. In case of nematode, cut the anterior extremity. Gently apply pressure from the posterior end. The testes alongwith intestine would come out. Separate thread-like testes.  
 (2) Place testes in 1% sodium citrate hypotonic solution in a cavity block.  
 (3) Fix the material in 3 : 1 methanol acetic acid for 15 to 20 minutes.  
 (4) Take a clean slide. Place a fixed testis over it with one or two drops of acetic acid. Tease the material and make a thin smear.  
 (5) Heat, dry slide at 45°C over hot plate.  
 (6) Place it over a watch glass horizontally. Flood the slide having smear for 5 to 15 minutes with Giemsa stain.  
 (7) Rinse slide with distilled water and keep it in vertical position for drying.  
 (8) If overstained, remove excess of stain with 40% acetic acid.  
 (9) Rinse the slide with xylol and mount with D.P.X. or Euperal. Let the slide become dry.  
 (10) Examine the slide under microscope.

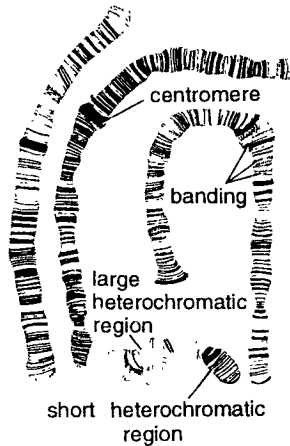

Fig. 7. Salivary gland chromosomes.

- (2) Because of their large size (100 to 150 mm) these are called giant chromosomes.
- (3) Giant chromosomes are called **polytene** due to their characteristic **banding pattern** or many-strandedness.
- (4) Centromeres are found in between the banding.
- (5) There are 3 larger chromosomes with characteristic heterochromatic regions at their tips. The fourth shortest chromosome has a long heterochromatic arm.
- (6) Cross bandings are very distinct.
- (7) Polytene chromosomes of Diptera represent widespread phenomenon of endopolyploidy.

**Identification :** Since the above chromosomes have giant size and banded appearance, they are giant chromosomes (Fig. 7).

**[IV] Giant or salivary chromosomes from *Chironomus* larva**

**Procedure :** Collect *Chironomus* larvae from a pond or drains. Pull the head region with the forceps. The salivary glands are exposed. Fix the glands in Carnoy's fluid. Place the glands on a slide, stain with acetocarmine and apply squash technique as in the case of onion root tip. Study the giant chromosomes under the microscope.

**Comments :** (1) Balbiani (1881) published account of giant chromosomes from salivary gland of *Chironomus* larva.

**3. Stages of Mitosis from Prepared Slides from Plant and Animal Materials**

**[I] Prophase**

- Comments :**
- (1) The nucleus becomes enlarged. DNA synthesis is completed. Prophase comes after interphase (Fig. 8).
  - (2) Chromosomes become filamentous, thin and distinct.
  - (3) Prophase may be early prophase or late prophase.

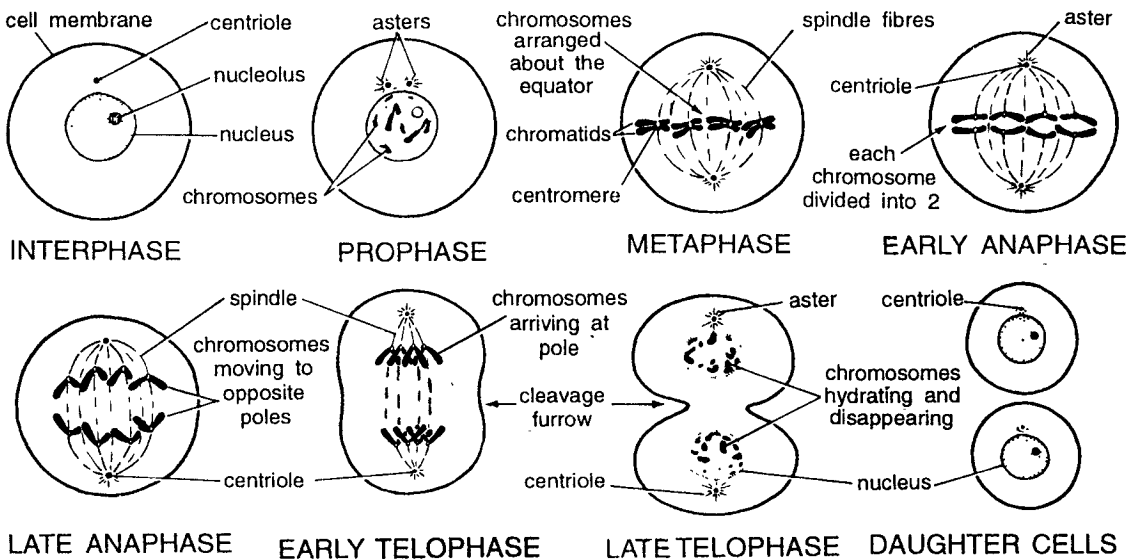

Fig. 8. Mitosis : Different stages.

- (4) In late prophase, each chromosome divides into sister chromatids attached at **centromere** or **kinetochore**.
- (5) Nuclear membrane and nucleolus disappear and cell enters into metaphase.

**Identification :** (1) Filamentous chromosomes **Early prophase**.  
 (2) Sister chromatids attached at centromeres-**Late prophase**.

### [II] Metaphase

- Comments :** (1) The spindle tubules start appearing and get attached with centromeres of chromosomes in early metaphase (Fig. 8).  
 (2) Chromosomes move actively and become arranged at the **equatorial plate** or **centre** in metaphase.  
 (3) Specially in animals, the centrosome helps in the formation of **spindle apparatus**. In plants, centrosomes are missing.  
 (4) Centrosome has two centrioles which separate and each occupies opposite sides of the nucleus.  
 (5) After metaphase next stage is Anaphase.

**Identification :** (1) Centromeres attach with spindle tubules-**Early metaphase**.  
 (2) Chromosomes arranged at equatorial plate-**Late metaphase**.

### [III] Anaphase

- Comments :** (1) Each chromosome splits at the position of centromere, forming sister chromatids or daughter chromosomes showing early anaphase (Fig. 8).  
 (2) The **sister chromatids move towards poles** with centromeres facing periphery while arms towards each other showing late anaphase.  
 (3) Depending upon the position of centromeres, the chromosomes may be **V-shaped, J-shaped, I-shaped, i.e., metacentric, sub-metacentric and acrocentric**, respectively.

**Identification :** (1) Chromatids separate and start moving towards poles-**Early anaphase**.  
 (2) Chromatids sub-equatorial-**Late anaphase**.

### [IV] Telophase

- Comments :** (1) The chromosomes reach towards poles in early telophase (Fig. 8).  
 (2) Nuclear membrane and nucleolus reappear.

**Identification :** (1) Chromatids reach at poles-**Early telophase**.  
 (2) Chromatids become surrounded by nuclear membranes-**Late telophase**.

### [V] Cytokinesis

**Comments :** (1) After appearance of the nuclear membrane two daughter nuclei are produced.  
 (2) Cytoplasm divides into two by a furrow. Cytoplasmic division is called cytokinesis.

**Identification :** Since these are two daughter cells, hence it is cytokinesis stage (Fig. 8).

## 4. Stages of Meiosis from Prepared Slides from Plants and Animal Materials

Meiosis involves two successive divisions forming four daughter cells, each having haploid number of chromosomes. (A) **In first meiotic division**, reduction in the chromosome number occurs without separation of chromatids. The stages involved are **Prophase I** (with 5 substages, *i.e.* **Leptotene, Zygotene, Pachytene, Diplotene** and **Diakinesis**), **Metaphase I**, **Anaphase I** and **Telophase I**. (B) **In second meiotic division**, separation of chromatids of chromosomes occurs. Four daughter cells with haploid chromosomes are formed during spermatogenesis in males and oogenesis in females. The stages of **second meiotic division** are **Prophase II, Metaphase II, Anaphase II** and **Telophase II**. These are similar to those of simple mitotic division already described which may be referred to for detailed comments.

### A. FIRST MEIOTIC DIVISION

#### [I] Leptotene (Leptonema) of prophase I

- Comments :** (1) This is the first stage after interphase (Fig. 9).  
 (2) Chromosomes appear as long thread-like structure interwoven together.  
 (3) Chromosomes give **beaded appearance** and are called as **chromomeres**.  
 (4) Ends of chromosomes are drawn towards nuclear membrane, near centriole.  
 (5) In plants no such polarization occurs.

**Identification :** Since chromosomes become thread-like and give beaded appearance, hence it is **leptotene stage**.

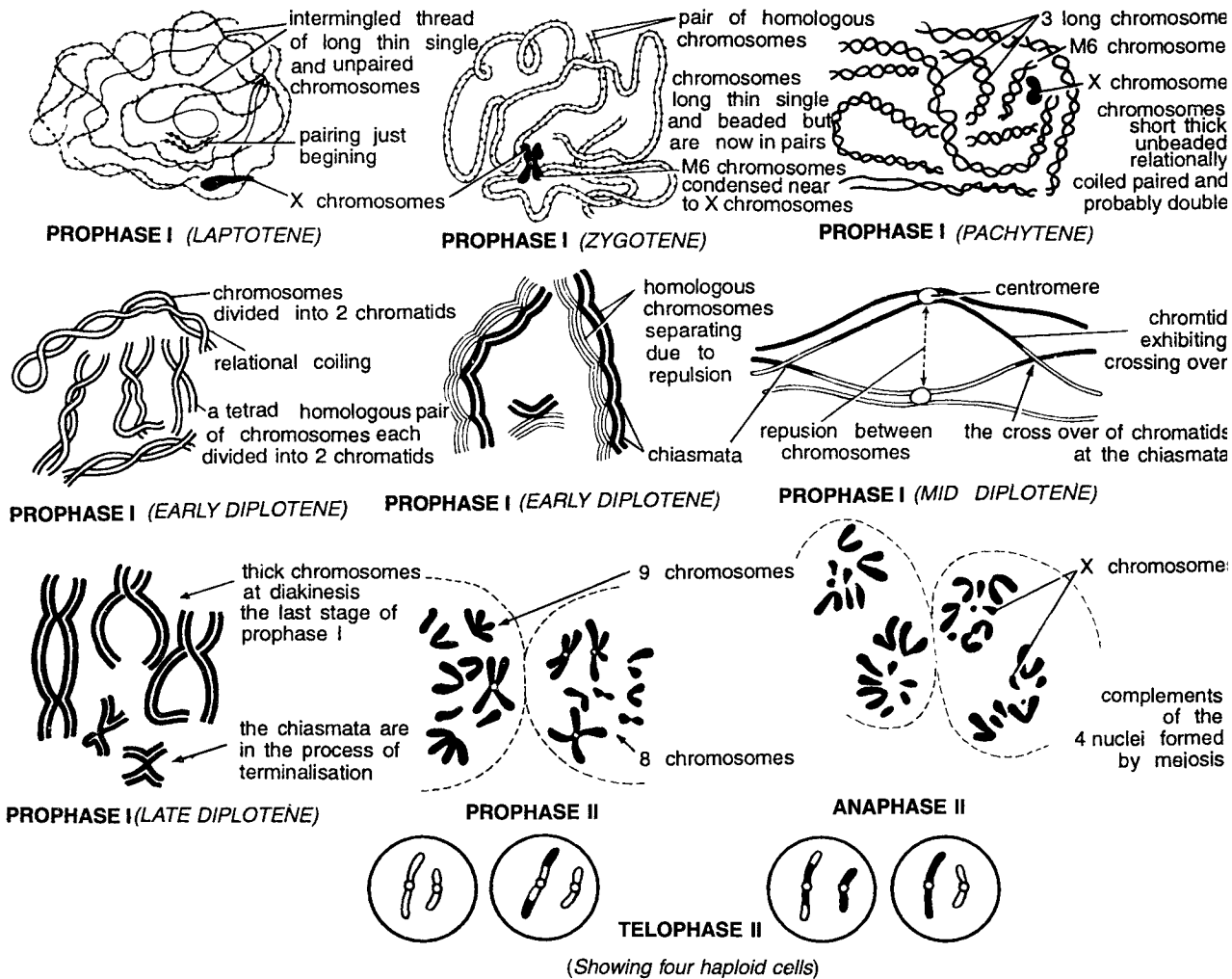

Fig. 9. Different stages of meiosis.

### [II] Zygotene (Zygonema) of prophase I

**Comments :** (1) This stage is characterized by the pairing of homologous chromosomes (synapsis).  
 (2) Pairing occurs in a zipper-like fashion and between two chromosomes at one region.

**Identification :** Since above chromosomes show pairing of homologous chromosomes, hence it is **zygotene stage**.

### [III] Pachytene of prophase I

**Comments :** (1) Chromosomes become shortened and coiled (Fig. 9).  
 (2) Chromosomes appear as thickened thread like structure, haploid in number. Each thread has two homologous chromosomes closely applied upon each other.

(3) These pairs of homologous chromosomes are called **bivalents**.

(4) Each bivalent really consists of four chromatids and is called **Tetrad**.

(5) Crossing over also occurs at this stage.

**Identification :** Since the above chromosomes show shortened, bivalent appearance, hence it is **pachytene stage**.

### [IV] Diplotene (diplonema) of prophase I

**Comments :** (1) Diplotene stage is characterized by thickening and condensation of chromosomes (Fig. 9).

(2) Homologous chromosomes start separating from one another. Separation starts from centromere and travel towards the ends. This is known as terminalization.

- (3) Double nature of chromosomes becomes distinct and hence the name of **diplotene**.
- (4) Homologous chromosomes remain in contact at certain points called **chiasmata**.
- (5) Chiasmata formation is characteristic of diplotene stage.

**Identification :** Since the above chromosomes show condensation, doubled structure and chiasmata formation, hence it is **diplotene stage**.

#### [V] Diakinesis of prophase I

- Comments :** (1) Chromosomes become more contracted and condensed.
- (2) Chromosomes appear as rounded bodies and they can be easily counted.
  - (3) **Bivalents** have tendency to move towards periphery near nuclear envelope.

**Identification :** Since the above chromosomes show rounded appearance and chiasmata formation, hence it is **diakinesis stage**.

#### [VI] Metaphase I

- Comments :** (1) After Diakinesis next stage *i.e.* first metaphase starts.
- (2) Chromosomes become more **condensed**.
  - (3) Spindle apparatus appears. Bivalents become attached to spindle.
  - (4) Bivalents are arranged at equatorial plate.

**Identification :** Since the above chromosomes are arranged at equatorial plate, hence it is **metaphase-I stage**.

#### [VII] Anaphase I

- Comments :** (1) Chromosomes of bivalents from equatorial plates move towards poles, in beginning of anaphase stage.
- (2) Two sister chromatids do not separate and go to the same pole, while in mitosis, the centromere divides longitudinally and the two sister chromatids pass to two different poles.
  - (3) Each pole has a haploid number of chromosomes.

**Identification :** Since chromosomes move towards poles hence it is **anaphase I stage**.

#### [VIII] Telophase I

- Comments :** (1) Nuclear membrane appears around group of chromosomes at the poles.

- (2) After formation of nuclei, chromosomes pass into a small **interphase** before the second meiotic division will start. As a result of above, dyad is formed. **Cytokinesis** is postponed till the end of second meiotic division.

**Identification :** Since chromosomes are at the poles and are in the form of dyad, hence it is **telophase-I stage**.

### B. SECOND MEIOTIC DIVISION

First meiotic division is followed by second meiotic division which is essentially the mitotic division. At II prophase chromosomes are already double, each having two sister chromatids which arrange at metaphase plate. Centromere splits forming two chromatids which move to poles. This is followed by II telophase and cytokinesis forming **four haploid cells**.

### 5. Demonstration of Mitochondria by Supra-Vital Stains

Mitochondria can be studied from buccal epithelial cells by staining them with supra-vital stains such as Janus green B, Neutral red and Methylene blue. Janus green B is generally recommended.

- Procedure :** (1) Prepare saturated solution of Janus green B in absolute alcohol.
- (2) Take a clean and dried slide. Flood it with Janus green B solution. Drain off excess of stain. Let the solution dry.
  - (3) Scrap with a tooth pick, portion of buccal epithelium. Spread the scrapping over the slide and cover it with coverslip.

**Result :** Examine the slide under compound microscope. Cytoplasm appears light green or colourless while dot-shaped mitochondria stain deep green in colour (Fig. 9A).

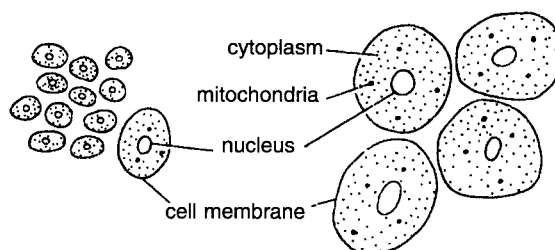

Fig. 9A. Mitochondria by Janus green stain.

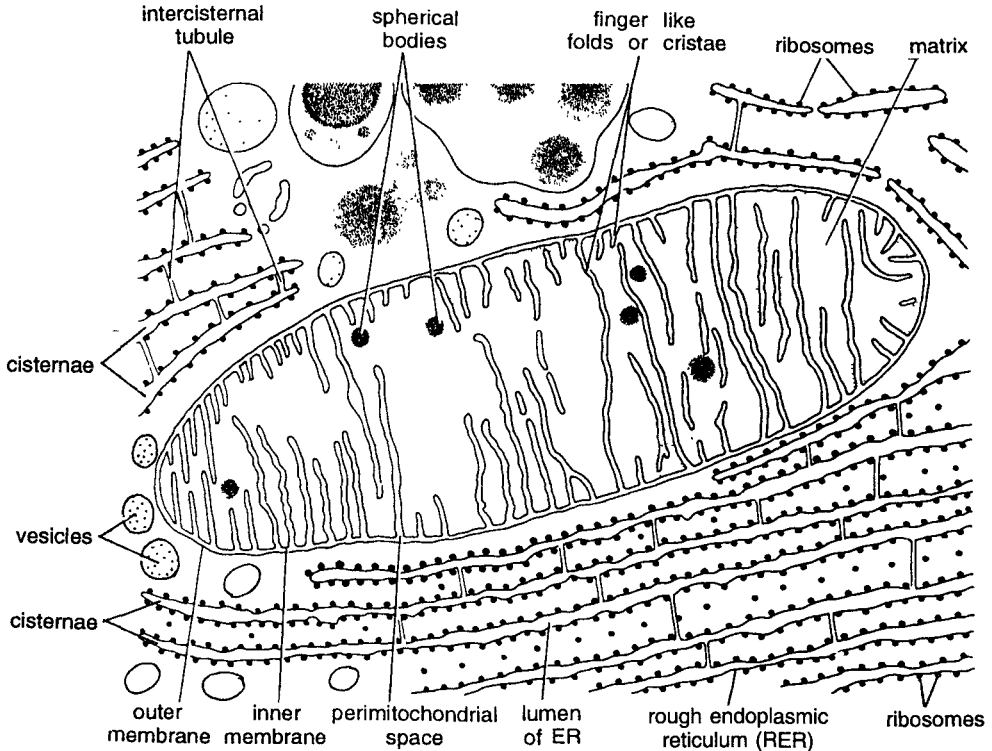

Fig. 10. Mitochondria and endoplasmic reticulum.

## 6. Microphotographs of Certain Cell Organelles

### [I] Mitochondria

**Comments :** (1) The microphotograph depicts the ultrastructure of mitochondria from a pancreatic glandular cell (Fig. 10).

- (2) Mitochondria appears as a rod-shaped structure consisting of **outer** and **inner** membranes.
- (3) Each membrane measures **6 nm** in thickness. Space between the two membranes is **6 to 8 nm** in thickness. Membranes have **protein lipid-protein** configuration.
- (4) Inner membrane divides mitochondria into two chambers : (i) **Perimitochondrial space** between two membranes and (ii) Inner chamber containing **matrix** and **cristae**.
- (5) Inner membrane is thrown into finger-like projections or folds called **cristae**.

- (6) Cristae have several **F<sub>1</sub>** particles on M face membrane facing matrix.
- (7) F<sub>1</sub> particles are responsible for **respiratory chain oxidative phosphorylation** and **ATP synthesis**.

**Identification :** Since the above microphotograph has double membranous structure with cristae, hence it is **mitochondria**.

### [II] Endoplasmic reticulum

**Comments :** (1) Ultrastructure of endoplasmic reticulum (ER) is from acini of pancreas (Fig. 10).

- (2) Name of endoplasmic reticulum was given by **Porter (1948)**. ER constitutes major part of cytoplasmic vacuolar system.
- (3) ER is in two main forms or profiles : (i) Long parallel forms called **cisternae**, (ii) small rounded forms called **vesicles**.
- (4) ER is a double membranous structure having outer and inner membranes with a lumen.

Cisternae are connected together by **intercisternal tubules**.

- (5) ER is called granular or rough because of presence of **ribosomes** over them. ER without ribosomes is called **smooth ER**.
- (6) Ribosomes are the sites of **protein synthesis**.
- (7) Endoplasmic reticulum functions to transport various nutritional chemicals new proteins and antigens in the cytoplasm.

**Identification :** Since the above microphotograph has tubular double membranous cisternae with ribosomes, hence it is **rough endoplasmic reticulum** (Fig. 10).

### [III] Golgi body

**Comments :** (1) Ultrastructure of **Golgi body** has been taken from ductus deferens (Fig. 11).

- (2) Golgi body was described and discovered by **Commilo Golgi** (1898) in Purkinje cells of Barn-owl.
- (3) Ultrastructurally Golgi body is double membranous structure. It consists of (i) **flattened** sacs of cisternae, (ii) small or large **vesicles** and (iii) **vacuoles**.
- (4) Golgi body has two faces : (i) a convex **forming face** from where small secretory vesicles are formed. These vesicles control the synthetic products of the cell. The vesicles reach outer-most membrane and fuse with it to release their product, (ii) **concave maturing face** from where large secretory vesicles are formed.

- (5) Golgi body is mainly concerned with several secretory activities such as **zymogen secretion, milk secretion, thyroglobin secretion, immunoglobulin, secretion, protein secretions, acrosome formation, sulfation and glycosylation.**

**Identification :** Since the microphotograph has cisternae, vesicles and vacuoles, hence it is **Golgi body**.

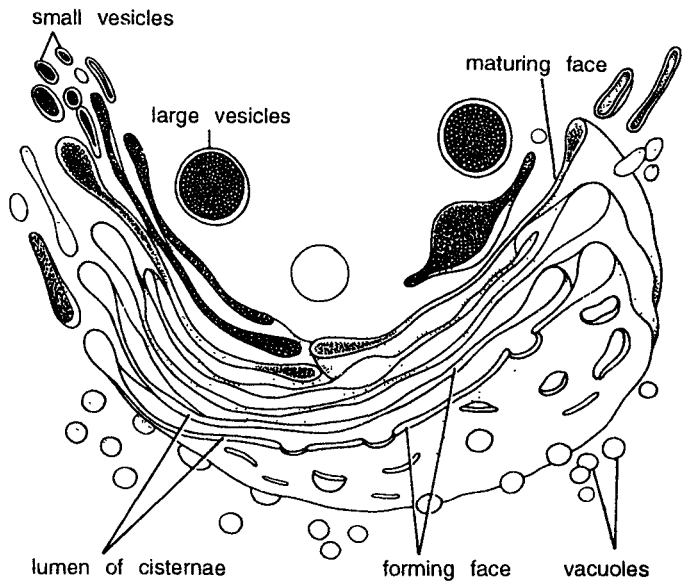

Fig. 11. Golgi body.

### [IV] Chloroplast

**Comments :** (1) Diagram of chloroplast has been taken from thin section of maize plant.

- (2) Chloroplast is lens-shaped, 4 to 8 microns in diameter (Fig. 12).
- (3) Chloroplast is covered by double membranous structure.
- (4) Between outer and inner membranes is periplastidial space of 10 to 30 nm thickness.
- (5) Cytoplasm is called **stroma** or **matrix**.

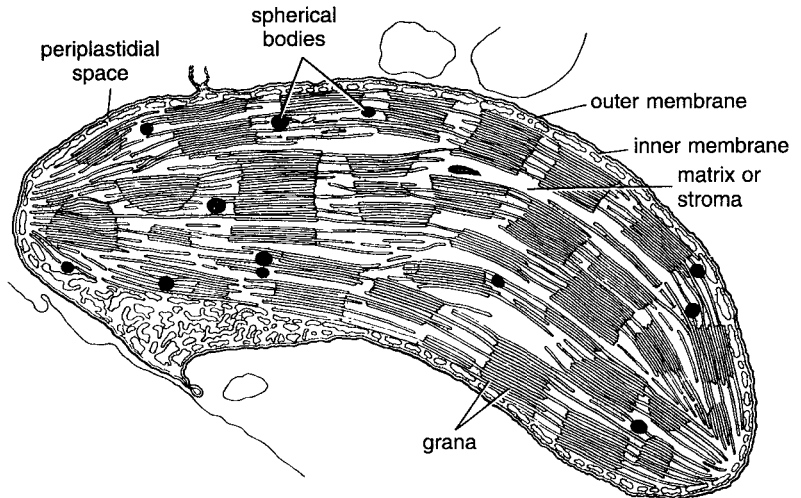

Fig. 12. Chloroplast.



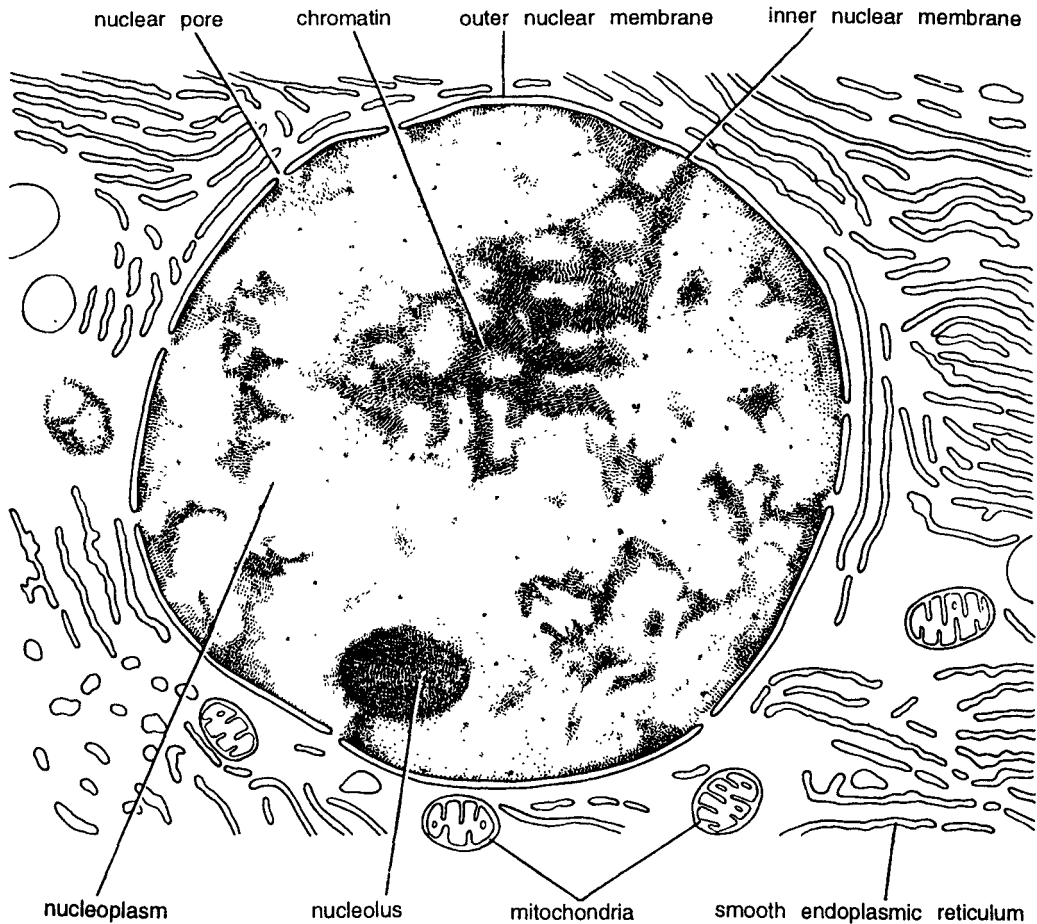

Fig. 13. Nucleus.

- (6) Matrix contains two kinds of lamellar systems : (i) **Grana lamellae** in the form of piles of coins concerned with light reactions of photosynthesis, (ii) **Single stroma lamellae** matrix concerned with dark reaction of photosynthesis.
- (7) Grana contains **chlorophyll** and accessory enzymes. Chloroplasts are important cell organelles where **photosynthesis** occurs.

**Identification** : Since the microphotograph shows piles of coin like grana lamellae hence it is chloroplast.

#### [V] Nucleus

**Comments** : (1) The microphotograph depicting ultrastructure of nucleus has been taken from a glandular cell of pancreas (Fig. 13).

- (2) Nucleus has **outer and inner membranes** measuring 7.5 nm in thickness.
- (3) Between two membranes is a perinuclear space or cisternae of 15 nm thickness.
- (4) Arrows indicate the pores. The Diameter of pores varies from 30 to 100 nm. Pores provide direct contact between cytoplasm and **nucleoplasm**.
- (5) Large eccentric dense and body is **nucleolus**.
- (6) Dark and dense substance is **chromatin** containing DNA.
- (7) Nucleus is a very important cell organelle concerned with structural, functional and hereditary aspects of living organisms especially in eukaryotes.

**Identification** : Since the above microphotograph has double membrane with pore like structures, hence it is **nucleus**.

# Study of *Drosophila* and Human Chromosomes

15

## Study of *Drosophila*

*Drosophila* is commonly called as **fruit fly** as it is commonly found around ripe fruits. It is specially used to study different aspects of animal genetics. The knowledge regarding sex **linked inheritance** of certain diseases has come through the studies on *Drosophila* for instance, colour blindness. *Drosophila* is very commonly used for genetics researches because of the following reasons :

- (1) It is commonly available everywhere.
- (2) Its life-cycle is short.
- (3) It can be easily maintained and cultured in the laboratory.

Different aspects of the study of *Drosophila* in laboratory are as under :

### 1. Collection of *Drosophila*

Fruit-fly has **cosmopolitan** distribution. Fruit flies can be easily collected. Keep a cut ripe fruit such as apple in a petri-dish in open. Fruit flies are attracted by ripe and cut fruits, they come and feed on fruits and they can be easily collected by brush. Collect these flies in a cleaned wide mouth test-tube or glass stoppered bottle and close the mouth of the test tube or glass-stoppered bottle by cotton plug. Bring the collection to laboratory. Study the

fruit flies under stereoscopic microscopes. Separate different fruit flies and keep them in different experimental tubes for culturing.

### 2. Culture of *Drosophila*

**Requirements :** (1) Small food vials for culturing the fruit flies.

- (2) Morgue bottles.
- (3) 250 cc glass stoppered or cotton plugged bottles.
- (4) 500 cc glass stoppered or cotton plugged bottles.
- (5) Stock bottle for storage of the feed.
- (6) Eitherizer bottle.
- (7) Re-eitherizer bottles.
- (8) Stainless steel needles.
- (9) Camel hair brush.
- (10) Glass marking pencil.
- (11) Petriplates (or) covered petri-dishes 3" size.
- (12) Plain glass slides.
- (13) Cavity slides.
- (14) Glass coverslips (squarish and rectangular).
- (15) Stereoscopic microscope.
- (16) Research binocular microscope.
- (17) 100 cc, 250 cc and 500 cc Borosil beakers.
- (18) 3% aqueous solution of sodium hypochlorite.

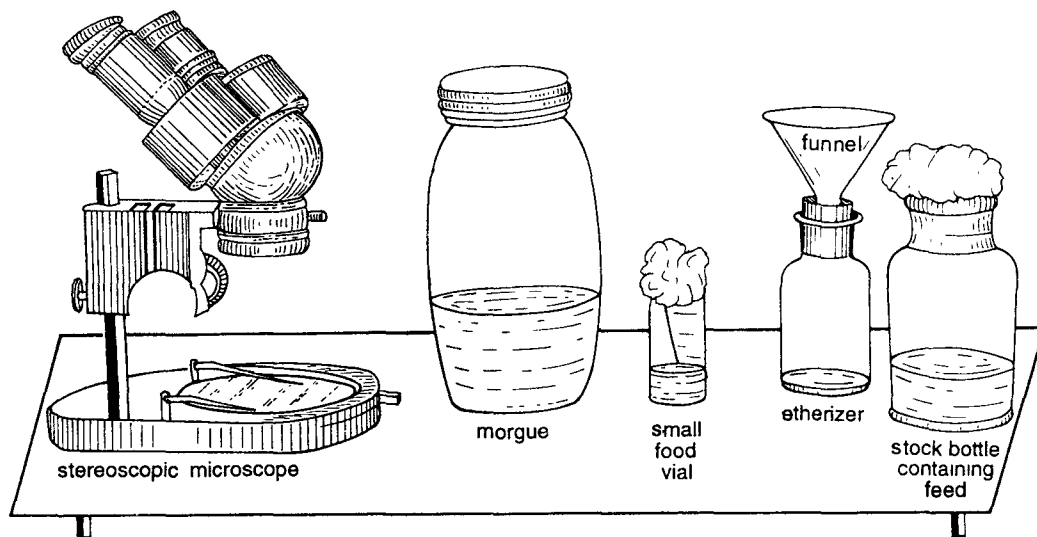

Fig. 1.

**Procedure :** For culturing and studying *Drosophila* etherizer and re-etherizer bottles are used. Take a 250 cc glass stoppered bottle. Close the mouth of the bottle with a cork. Make a hole in the cork through the neck of the glass funnel. Put either soaked cotton plug in opening of the bottle. Collect fruit flies in bottle and close with either soaked cotton. Fruit flies become inactivated. Inactivated fruit flies can be easily studied under the microscope. If during microscopic studies the *Drosophila* become active, then a fresh either soaked cotton plug is used in the neck of the funnel. Flies become again inactivated. Under stereoscopic microscope different species of *Drosophila* are separated. Process of making the fruit flies inactive again is called re-etherization.

### 3. Preparation of Feed Medium for fruit flies

The feed of the flies is prepared by mixing definite proportion of the following gradients. In a large glass bowl keep 1400 ml of tap water, add 72 gm corn-flour, 64 gm sugar, 64 gm resin, 24 gm agar agar, 24 gm yeast, 5 ml propionic acid and 1 or 2 gm fungicide (if necessary). Depending upon the requirement the feed quantity can be increased by increasing the gradients 4 or 5 times or 10 times.

Mix the gradients well and store the feed in a stock bottle. From stock bottles, take the feed and keep the feed in food vials (number of feed vials as per requirement).

### 4. Study of Life-cycle Stages of *Drosophila*

Collect *Drosophila* as described above. From collection bottles, transfer 15 to 20 fruit flies in 8 cm long, 2.5 cm wide food vials. Close the mouth of the vial with a cotton plug. Keep the food vials containing the flies in BOD incubator maintained at a temperature of 15 to 20 degree. Life-cycle is completed within 10 to 15 days. All the life-cycle stages of *Drosophila* could be studied in these food vials (Fig. 2).

Male and female flies copulate. After 2 to 3 hours of copulation female lays fertilized eggs. After 24 hours of fertilization egg hatches into **first instar larva**. First instar larva changes into **second instar larva** after 3 days. Fifth day second instar larva changes into **third instar larva**. On sixth day third instar larva changes into **pupa**.

Collect different stages from the food vials on different days and fix them in corrosive sublimate solution for 5 to 10 minutes. After fixing them keep the stages in 3% chlorax solution (3 gm of sodium hypochloride + 100 cc distilled water) and then in distilled water. Dehydrate the developmental or

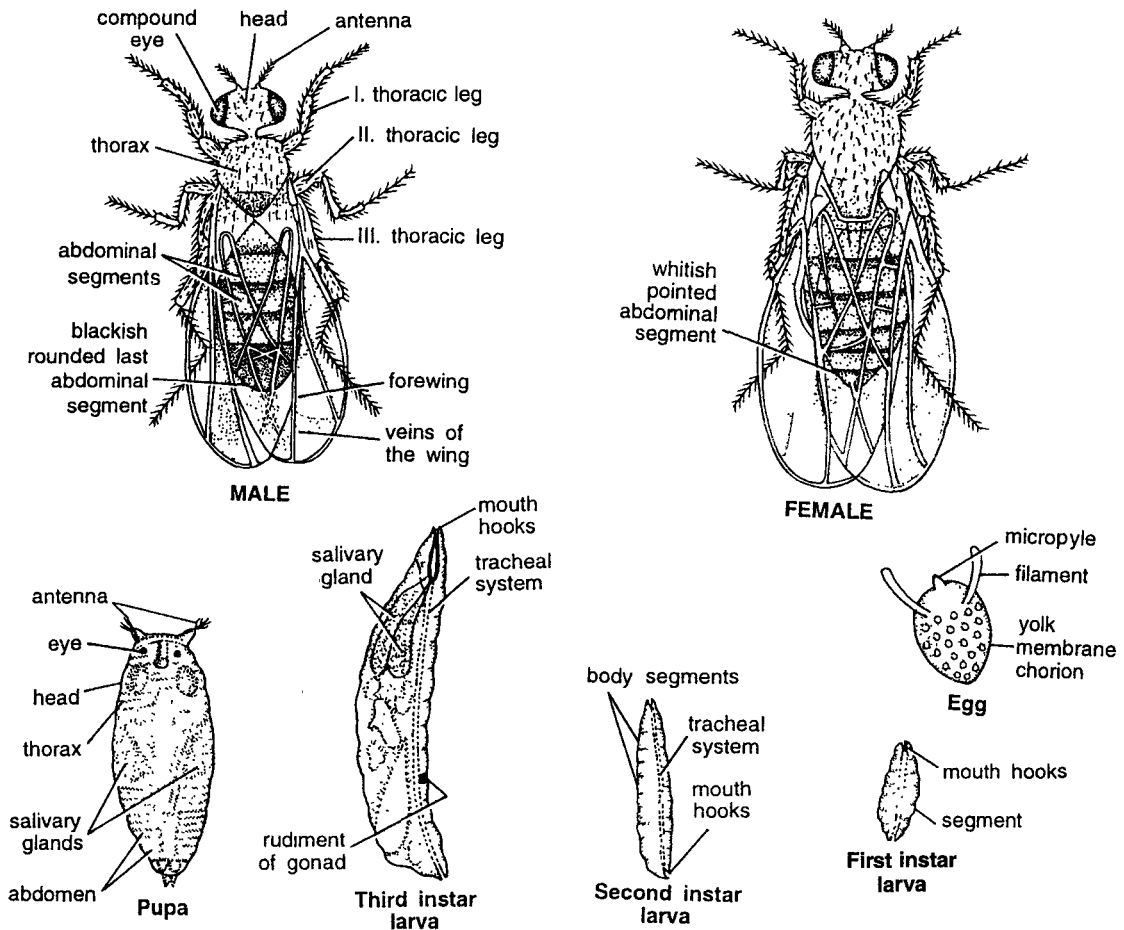

Fig. 2. *Drosophila*. Stages of Life Cycle.

life-cycle stages in 30%, 50%, 70%, 90% and 100% alcohols clear in xylol and mount in DPX. Legs and wings of *Drosophila* are mounted by above methods.

### 5. *Drosophila* : Eggs

- Comments :** (1) Eggs are oval in shape measuring 0.5 mm in length and 0.2 mm in breadth.  
 (2) Dorsal side of the egg is flatter than concave ventral side (Fig. 1).  
 (3) Antero-dorsal part of the egg contains **two filaments**.  
 (4) Filaments prevent eggs from sinking in wet medium and also ensure vital oxygen supply.  
 (5) Two above filaments are formed from the extension of the chorion of the egg envelope.

- (6) Chorion and filaments are secreted by the follicle cells surrounding the egg during **oogenesis**.  
 (7) Anteriorly egg contains an opening on raised structure called as **micropyle**.  
 (8) Sperm enters through the micropyle for fertilization.  
 (9) Surface of the egg shows honey comb like appearance.

### 6. *Drosophila* : First, Second and Third Larval Stages

- Comments :** (1) After 24 hours of fertilization egg hatches into **first instar larva**. These larvae are seen crawling in the culture vials around yeast cells (Fig. 1).  
 (2) Larvae feed on yeast cells.

Male	Female
<ol style="list-style-type: none"> <li>1. Males smaller in size.</li> <li>2. Have 5 abdominal segments.</li> <li>3. Posterior abdominal segment is black and rounded.</li> <li>4. First tarsal segment of I-thoracic leaf has characteristics-sex-comb. Sex-comb consists of row of about 10 short thick, black bristles.</li> </ol>	<ol style="list-style-type: none"> <li>1. Females larger in size</li> <li>2. Have 7 abdominal segments.</li> <li>3. Posterior abdominal segments is transparent and pointed protruding anal plate.</li> <li>4. Sex-comb absent.</li> </ol>

- (3) First instar larva (4) is characterised by having **body segments** and mouth hooks anteriorly.
- (4) After 24 hours of hatching first instar larva changes into **second instar larva** (L<sub>2</sub>).
- (5) L<sub>2</sub> is characterized by having cylindrical body. Larva has grown in size and is characterized by having **mouth hooks**, body segments and **tracheal system**.
- (6) On fifth day second instar larva changes into **third instar larva** (L<sub>3</sub>).
- (7) Third instar larva has grown considerably measuring 4 to 5 mm in length with narrow anterior and broad posterior region. L<sub>3</sub> is characterized by having **mouth hooks**, **salivary glands** **tracheal system** and rudiments of gonads.
- (8) On sixth day third instar larva changes into **pupa**.

### 7. *Drosophila* : Pupa

- Comments :** (1) At the end of third larval stage it is enclosed in **Puparium**. After an internal molt larval cuticle is changed into pupal case.
- (2) Inside puparium body is divisible into **head**, **thorax** and **abdomen**. Pupa has rudiments of almost all the organs (Fig. 1).
  - (3) Head contains **antenna** and compound eyes.
  - (4) In thoracic region there is salivary gland.
  - (5) Abdominal segments are clearly visible.
  - (6) Pupa contains folded impressions of **appendages** and **wings**.
  - (7) Initially puparium is white but in 2 hours colour changes to yellow then to dark brown and **pupal case** hardense.
  - (8) By histolysis some larval organs and tissues are broken down by histolysis.
  - (9) Salivary glands visible.

- (10) Pupa metamorphosis into adult. A single egg would give rise either to male or female fruit fly.

### 8. Identification of Male and Female *Drosophila*

#### *Drosophila* : Male

- Comments :** (1) Males are smaller than females.
- (2) Body is divided into **head**, **thorax** and **abdomen** (Fig. 1 and Table 1).
  - (3) **Head** contains large **compound eyes** and a pair of **antennae**. Antennae bear setae or brisks.
  - (4) **Head** is joined to thorax by a narrow neck.
  - (5) **Thorax** contains paired thoracic legs (fore legs) II. Thoracic leg (mid-legs) and III. Thoracic legs (third legs). Each leg bears setae or bristles.
  - (6) Thorax contains wings extended beyond abdomen.
  - (7) Abdomen contains 5 segments. Last abdominal segment is **black** and **rounded**.

#### *Drosophila* : Female

- Comments :** (1) Females are larger than males.
- (2) Body divisible into **head**, **thorax** and **abdomen** (Fig. 1, Table 1).
  - (3) **Head** contains paired large **black compound eyes** and paired antennae. Antennae contain bristles.
  - (4) **Thorax** contains 3 pairs of legs and 2 pairs of wings. Thorax and legs contain large number of bristles.
  - (5) **Abdomen** contains 7 segments.
  - (6) Last abdominal segment contains anal plates which are pointed and last abdominal segment looks like pointed.
  - (7) Hind wings in fold condition extend males beyond last abdominal segment.

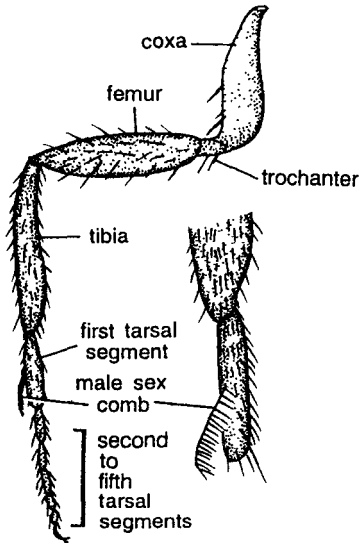

MALE SEX COMB

Fig. 3. *Drosophila*. Fore leg and sex comb.

### 9. *Drosophila* : Fore legs and Sex-comb of Male

- Comments :** (1) Foreleg is composed of **coxa**, **trochanter**, **femur**, **tibia** and 5 jointed tarsus.
- (2) First tarsal segment contains **sex-comb**. Sex-comb contains 10 black coloured **bristles**.
- (3) Fore leg contains large number of bristles (Fig. 3).

### 10. *Drosophila* : Wing

- Comments :** (1) 2 pairs of membranous wings, fore wings smaller (Fig. 4).
- (2) Hind wings larger extending beyond abdomen.
- (3) Hind wings contain anterior cross-veins, longitudinal veins and posterior cross veins.

### 11. *Drosophila* : Diagnostic Features of wild and Mutant Varieties

#### [I] Wild type

- Comments :** (1) Body divisible into **head**, **thorax** and **abdomen**. Head contains **antennae** and **compound eyes** (Fig. 5A).
- (2) Wild type was grey or brown colour.
- (3) **Eyes** are brick red colour.
- (4) Thorax contains wings, halteres and secretellum.

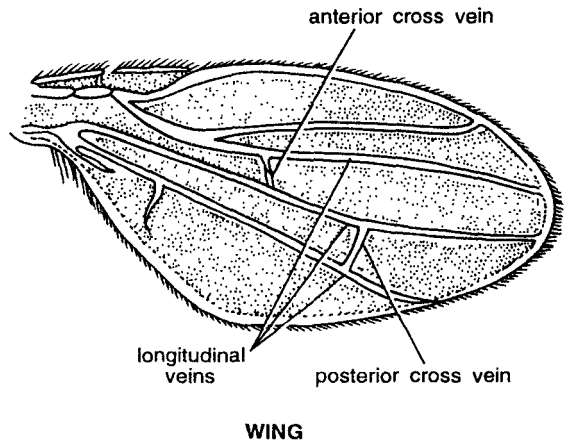
Fig. 4. *Drosophila*. Wing.

#### [II] Mutant types

Certain mutant types are as under.

##### (a) *Drosophila* : Yellow body

- Comments :** (1) Body divisible into **head** thorax and **abdomen** (Fig. 5A).
- (2) Head contains **antennae** and **compound eyes**.
- (3) Thorax contains 3 pairs of legs and 2 pairs of wings.
- (4) Colour of the adult fruit fly **Yellow**.

##### (b) *Drosophila* : Curly wings

- Comments :** (1) Body divisible into **head**, **thorax** and **abdomen** (Fig. 5B).
- (1) Head contains antennae and compound eyes.
- (2) Thorax contains 3 pairs of legs and 2 pairs of wings (fore wings and hind wings)
- (3) Hind wings are curly. They are curled upwards.

##### (c) *Drosophila* : Scalloped

- Comments :** (1) Body divisible into **head**, **thorax** and **abdomen** (Fig. 5C).
- (2) Head contains **antennae** and **compound eyes**.
- (3) Thorax contains 3 pairs of legs and paired fore wings and hind wings.
- (4) Wings have abnormal edges.

##### (d) *Drosophila* : Apterous

- Comments :** (1) Body divisible into **head**, **thorax** and **abdomen**.
- (2) Head contains **compound eyes** and **abdomen**.

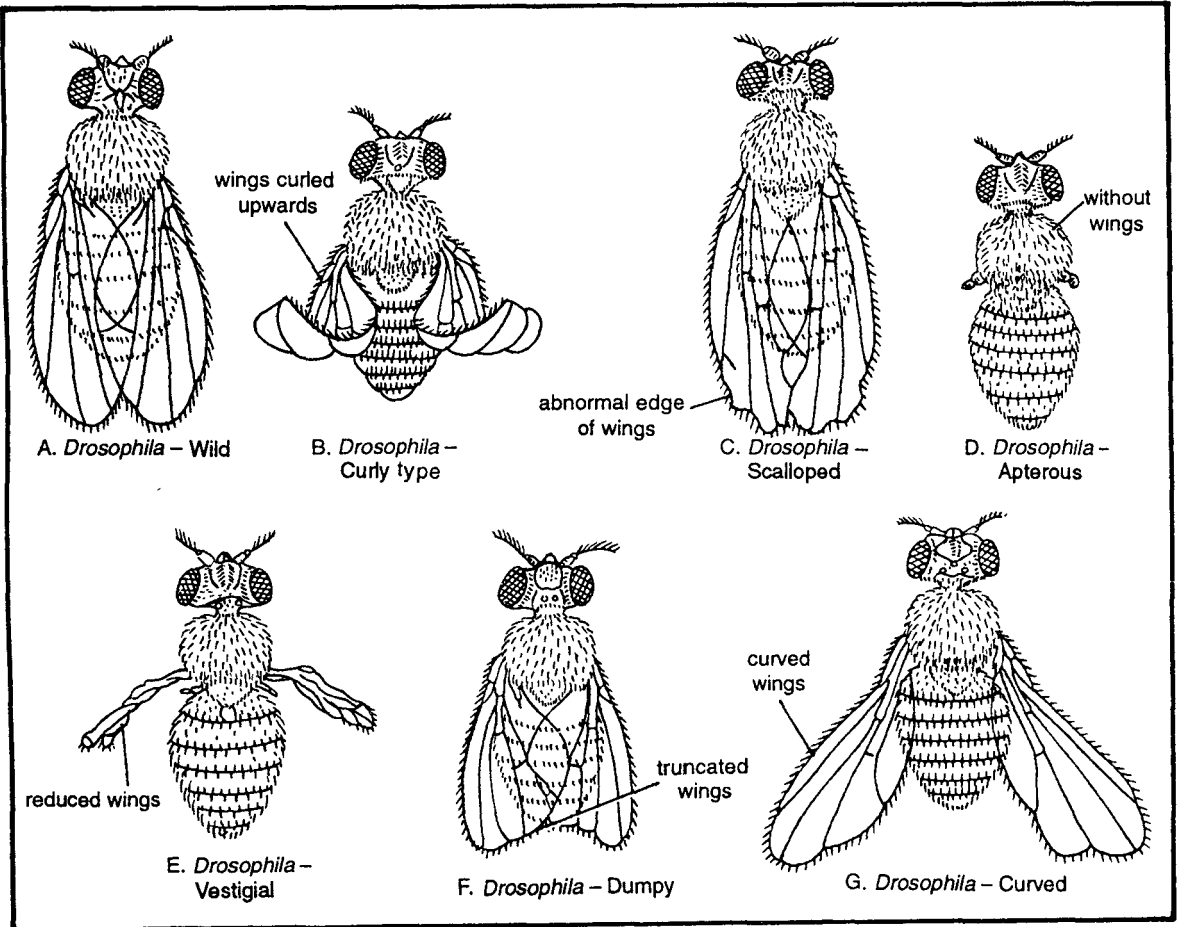

Fig. 5. *Drosophila*. Wild and mutant types.

(3) **Wings absent** hence **apterous** (Fig. 5D).

(4) Bristles present all over body.

(e) *Drosophila* : **Vestigial**

**Comments** : (1) Body divisible into **head**, **thorax** and **abdomen** (Fig. 5E).

(2) Head contains small antennae and compound eyes.

(3) Thorax has 3 pairs of legs.

(4) **Wings reduced**.

(f) *Drosophila* : **Dumpy**

**Comments** : (1) Body divisible into **head**, **thorax** and **abdomen** (Fig. 5F).

(2) Head contains **antennae** and **compound** eyes.

(3) **Wings truncated**.

(4) Bristles present all over body.

(g) *Drosophila* : **Curved**

**Comments** : (1) Body divisible into head, thorax and abdomen (Fig. 5G).

(2) Head contains compound eyes and antennae.

(3) Bristles present all over the body.

(4) **Wings curved**.

## 12. *Drosophila* or Chironomous Larva

Study of DNA by Feulgen reaction. DNA can be studied in the salivary glands of *Drosophila* or **chironomous** larva.

**Principle** : DNA (Deoxyribonucleic acids) can be studied in the paraffin sections of salivary glands of *Drosophila* or **chironomous** by **Feulgen-Schiffs** reaction. Feulgen and Rosenbeck (1924) and Pearse (1968) studied

above reaction for DNA. In this reaction DNA is denatured by hydrolization at 60°C. During this process **deoxypentose sugar** and **aldehydes** of DNA are separated. After hydrolization tissues are subjected to Schiff's reagent. The chromatin stained and purple colour is obtained.

**Procedure :** (a) **Preparation of Schiff's reagent :**

Schiff's reagent prepared by Berger and Delamater (1948) gives best result. Take a 500 cc conical flask and clean it by chromic acid solution. Chromic acid solution is prepared by mixing 10 gm potassium dichromate in 100 cc of concentrated sulfuric acid (1180). Rinse conical flask by chromic acid solution. Wash the flask 9 times with tap water and 3 times with distilled water. Keep flask in inverted position for drying on a filter paper. Dissolve 1 gm basic fuchsin in 400 cc of boiling distilled water in a conical flask. Borosil or Corning conical flask should be taken. Cool the flask to 50°C and then filter it in another conical flask. To the filtrate add 1 cc of thionyl chloride. Let the solution stand for 12 hours in dark. Add 2 gm activated charcoal to the solution. Shake it for 1 to 2 minutes. Filter the solution and store in the dark at 0°- 4°C.

(b) **Feulgen staining method :** Dissect *Drosophila* or take out salivary glands of Chironomous larva. Fix the salivary glands in 10% formalin solution. Prepare paraffin sections of salivary glands. Dry the sections for 24 hours. Keep the sections in xylene to remove. Pass the sections through 100%, 90%, 70%, 50%, 30% alcohols and then into distilled water. Keep the sections in N-HCL (normal hydrochloric solution) at 60°C for 30 min. for denaturation of DNA. After this keep the sections in cool N-HCL and then in distilled water. Then stain in the sections in Schiff's reagent. After staining wash the sections in potassium bisulphide, then in ammonium chloride and then in distilled water. Dehydrate sections in 30, 50, 70, 90 and 100% alcohols. After dehydration keep sections in xylene for 5 to 10 minutes and then mount them in DPX.

**Result :** In the sections purple coloured dot shaped structures depict DNA.

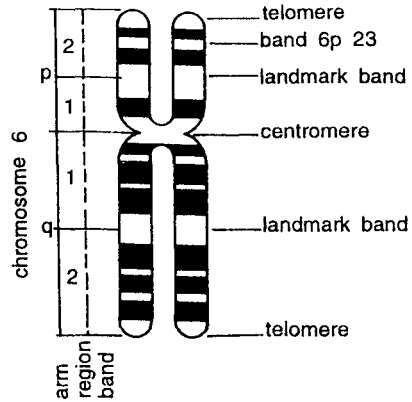

Fig. 6. Man. Chromosomes.

### Study of Human Chromosomes

**Procedure :** Human chromosomes can be studied by **Giemsa** staining and by G. banding technique. Human chromosomes and karyotypes can be studied by tissue culturing of **skin, fibroblasts, bone marrow**, peripheral blood. Colchicine and hypotonic solution is used to block mitosis at metaphase stage and to separate the chromosomes.

Take a small vial or glass tube and add a little anticoagulant in it. Take blood from tip of the finger and mix it with anticoagulant. Separate serum and blood corpuscles by centrifugation. Take blood corpuscles over slide and treat with 1% potassium chloride solution or 1% sodium citrate solution. After this flood the slide with carnoy fluid or 3 : 1 methanol acetic acid for 15 to 20 minutes for fixing the chromosomes. Keep the slide for drying for one week. Write date over the corner of the slide. After a week treat the slide with 0.25% trypsin solution (0.25 gm trypsin + 100 cc distilled water). Wash the slide with 100% alcohol. Dry the slide and then stain with Giemsa stain, and mount in DPX.

**Comments :** (1) By Giemsa staining detailed structure can be studied (Fig. 6).

(2) By **G banding** 3 kinds of chromatin can be seen (i) **centromeric** or **kinetochromatic** which are **heterochromatin**, (ii) **intercalary heterochromatin**, and (iii) **euchromatin**.



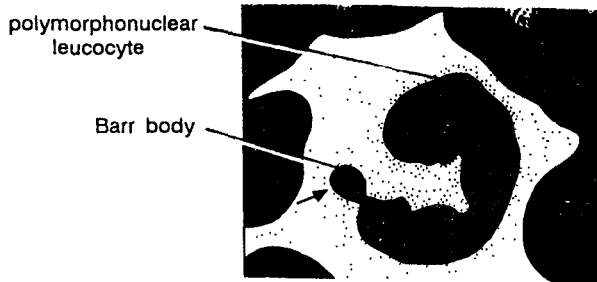

Fig. 7. Female. Barr body.

- (3) In chromosomes 6 bands can be seen like telomere, centromere and land mark band, etc.
- (4) Q band and G bands are equal.
- (5) G bands contain excess of adenine and thymidine bases.
- (6) G and Q bands are active in transcription.
- (7) Human chromosomes depicts macrocoiling.

#### Barr body

Barr and Bertram (1949) made outstanding discovery that in the interphase nucleus of **females**, there is small chromatin body called as sex chromatin or **Barr body**. This sex-chromatin body is absent in **males**. Now this chromatin body is called as **X-chromatin**.

**Medical significance :** Study of above has great medical applications and it has potential to relate certain congenital diseases and chromosomal abnormalities. In Olympic games certain males disguise themselves as females to compete in the events of female games. Barr body helps in identification of such **suspected males** because it is absent in males.

The X-chromatin in interphase stage become heterochromated and condensed and are best seen. Frequency of detection of X-chromatin or Barr body varies with tissues to tissue-60% in nervous tissue, 96% in amniotin epithelium and in oral smears and leucocytes 20-50% and in human polymorphic (polymorphonuclear leucocytes). Barr-body is clearly observed as **drum stick** in a nuclear appendage.

**Procedure :** From the finger tips of females, blood is collected by puncturing the tip of finger by sterilized needle. Make a thick blood film of the blood on slide. Let the film dry for 30 minutes. Treat the slide with a mixture of glacial acetic acid and tartaric for hydrolysis of haemoglobin. Stain the slide with **Leishman stain** and wash the slide with tap water. Dry the slide and study under oil immersion.

**Result :** Barr body is seen like **drumstick** in one of the nuclear appendage of a chromosome.

Experimental ecology includes the following experiments :

- (1) Study of certain **modifications** in animals due to micro-ecological and macro-ecological conditions. In the former, modifications or adaptations in various parasites because of differential micro-ecological niches, and in the latter certain aquatic and aerial modifications, are studied.
- (2) Study of **biotic** and **abiotic** factors.

## Modifications or Adaptations

Micro-ecological conditions such as pH, enzymes and other chemical constituents, affect the parasites which undergo various modifications.

### 1. Blood fluke (*Schistosoma*)

**Comments :** (1) Blood flukes live in blood vessels of vertebrates. Blood vessels provide nutritionally very rich environment for the parasites. There are three species of blood flukes found in man namely *Schistosoma haematobium*, *S. mansoni*, *S. japonicum*.

- (2) In order to swim freely in tubular blood vessels, their dorsoventrally flattened body becomes tubulated.
- (3) Ventral sucker present but not meant for attachment.
- (4) Female is always carried by the male in his **gynecophoric canal**.
- (5) Outer covering is tegument through which sugars, amino acids and lipids are observed.

### 2. Liver fluke (*Fasciola*)

**Comments :** (1) Micro-ecologically these parasites live in the bile duct, biliary passages and live in the lobules of sheep, man and other herbivorous mammals. Four species namely *Fasciola hepatica*, *Fasciola gigantica*, *F. indica* and *F. magna* are prevalent.

- (2) Body of parasite is soft, shiny and dorsoventrally flattened.
- (3) Parasite can roll its body inside the bile duct and liver lobules.
- (4) Ventral sucker or acetabulum has strong radial muscles. It forms a sort of vacuum to attach with the host tissues.

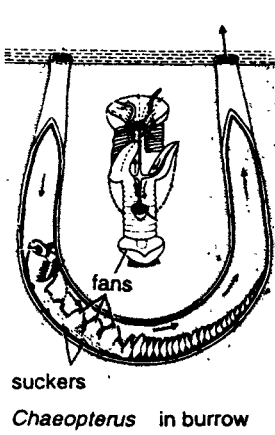

*Chaetopterus* in burrow

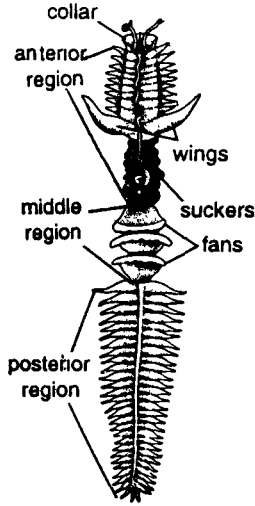

*Chaetopterus*

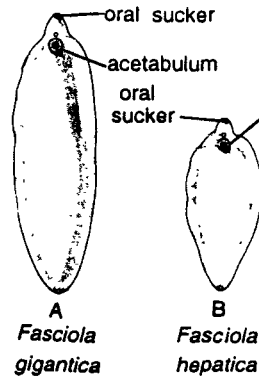

*Fasciola gigantica* *Fasciola hepatica*

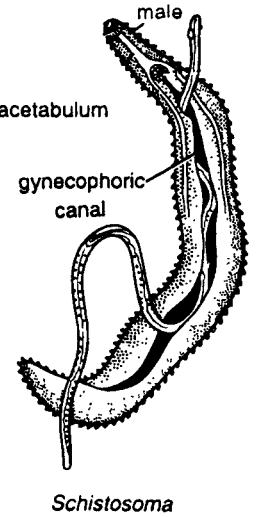

*Schistosoma*

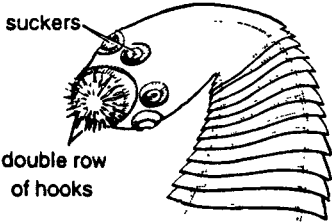

suckers  
double row of hooks

*Taenia solium*

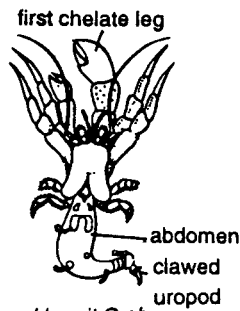

first chelate leg  
abdomen  
clawed uropod  
*Hermit Crab*

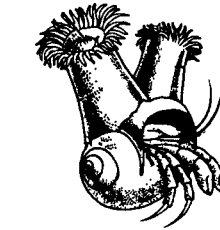

Hermit crab and sea anemone

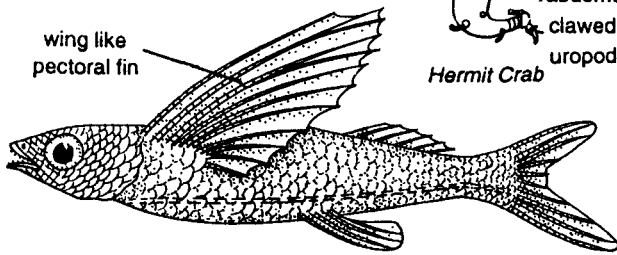

wing like pectoral fin

*Exocoetus*

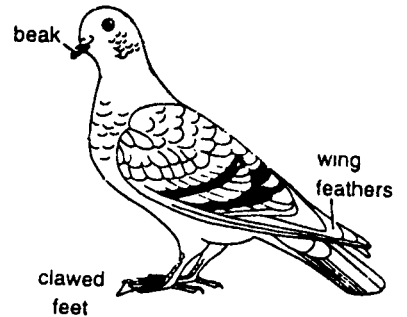

beak  
wing feathers  
clawed feet  
*Columba livia*

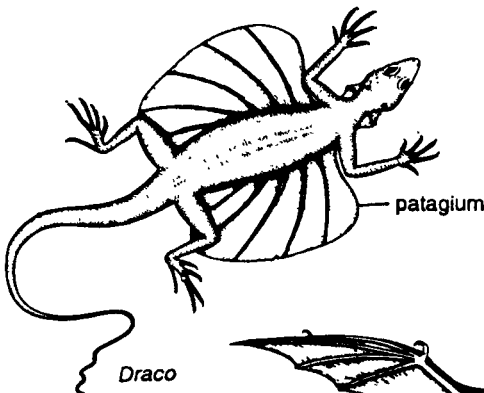

patagium

*Draco*

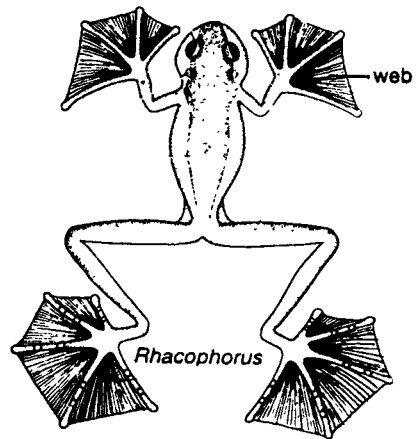

web

*Rhacophorus*

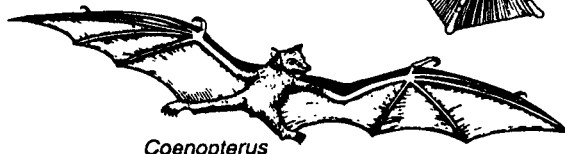

*Coenopterus*

- (5) Anterior extremity has oral sucker for feeding and sucking.

### 3. Tapeworm (*Taenia solium*)

**Comments :** (1) *Taenia solium* is found in the small intestine of man. Small intestine provides very good micro-ecological niche for these cestodes.

- (2) Body is divided into **scolex**, **neck** and strongly dorsoventrally **flattened segments**.  
 (3) Scolex lies buried in the intestinal mucosa. It has four well developed suckers for firm attachment.  
 (4) Attachment is further strengthened by the presence of a cirlet of small and large rostellar hooklets or hooks. Each hook is **anchorshaped**.  
 (5) Digestive system completely absent.  
 (6) Body is covered with tegument through which amino acids, sugars and other nutritional chemicals are absorbed.

### 4. Chaetopterus

**Comments :** (1) *Chaetopterus* is a marine polychaete tubicolous worm. Its burrow is made up of sand and mucous. Because of tubicolous, sedentary and ciliary feeding the animal shows several modifications.

- (2) **Notopodia** of 15 to 20 anterior segments form a **collar** of funnel-like structure for generating water current inside the tube or burrow.  
 (3) There is a mucous bag anteriorly to filter the food.  
 (4) Notopodia of tenth segment becomes enlarged and **aliform** (wing-like) for collecting food (particles).  
 (5) Three middle segments are modified as **fan-like** structures. They have strong muscles and act as pumping organ to maintain the water current.  
 (6) Posterior body region has reduced segments.

### 5. Hermit crab (*Eupagurus*)

**Comments :** (1) Hermit crabs are marine anomuran crustaceans. On every sea beach several hermit crabs are seen occupying molluscan shells. Only their appendages are seen moving. Rest of their body remains inside the shell.

- (2) Body proper is asymmetrical and divided into cephalothorax and abdomen.  
 (3) Right chelate leg, right antennae and right walking legs are larger than left ones.  
 (4) Abdomen is asymmetrical, soft, fleshy, elongated and twisted to fit inside the coils of the shell. Abdominal appendages of right side absent while reduced on left side.  
 (5) Sixth abdominal segments or **uropods** are modified as hook-like structures to be anchored inside the shell.  
 (6) Sea anemones are attached on the external surface of the mollusc shell. The sea anemone, mollusc shell and hermit crab show fine example of **commensalism**.

### 6. Flying fish (*Exocoetus*)

**Comments :** (1) Flying fish is found in warmer seas. It is pelagic feeding on prawns etc.

- (2) Body is elongated. **Pectoral fins** are **exceptionally large**, spread like wings for gliding.  
 (3) Pelvic fins are also adapted to lift the body out of water.  
 (4) By powerful strokes of pectoral fins, fish is able to leave water to avoid enemies. It glides over the surface of the water.  
 (5) Ventral lobe of tail fin is elongated (hypoblastic tail).

### 7. Flying frog (*Rhacophorus*)

**Comments :** (1) *Rhacophorus* lives on trees. It has completely modified itself for aerial mode of life by gliding.

- (2) Body of the frog is comparatively lighter.  
 (3) Hind limbs are elongated.  
 (4) Both the fore and hind limbs contain **well developed** webs which act as **parachutes** during gliding.  
 (5) Digits contain adhesive pads for attachment.

### 8. Flying lizard (*Draco*)

**Comments :** (1) Flying lizard lives on trees and is adapted for aerial environment and arboreal living.

- (2) Body is **dorsoventrally compressed**.  
 (3) Thoracic ribs are expanded and folds of skin between them form patagia or membranous wings, one on either side of body.

### 9. Pigeon (*Columba livia*)

**Comments :** (1) Pigeon is the most familiar bird. It shows several modifications for aerial mode of life.

- (2) Eyes are large with monocular vision.
- (3) Neck is short and mobile.
- (4) Fore limbs are modified into wings. Tail feathers elongated.
- (5) Hind limbs have claws and modified for walking as well as **perching on trees**.
- (6) Body is very light because of **pneumatic bones**.

### 10. Bat (*Cynopterus*)

**Comments :** (1) Amongst mammals extreme modifications for arboreal life are shown by bats.

- (2) Forelimb bones are elongated for supporting membranous wings.
- (3) Skin folds forming membranous wings or patagia are well developed.
- (4) Bats are capable of true flight. They are mostly nocturnal and swift fliers.

## STUDY OF BIOTIC AND ABIOTIC FACTORS

Every ecosystem consists of abiotic and biotic factors.

#### 1. Abiotic factors contain :

- (1) **Inorganic substances** such as chlorides, sulphates, phosphorus, sulphur, nitrogen, hydrogen, etc.
- (2) **Organic substances** such as carbohydrates, proteins and lipids.
- (3) **Climatic conditions** such as rains, temperature, light, moisture, etc.

2. **Biotic factors** consist of autotrophs, heterotrophs, producers and consumers.

### A. Study of Biotic Factors

#### EXERCISE (1)

**Object :** Study of ecosystem in a glass trough.

**Procedure :** Take a glass trough or a small aquarium and fill it three-fourth with ordinary tap water. Make its bottom rocky and muddy.

Plant on the bottom *Hydrilla*, *Chara* or *Vallisneria*. Add *Spirogyra* and *Nymphaea* as floating plants. Add certain ciliates, *Euglena*, *Cyclops*, *Brachionus*, etc. Keep some frogs and fishes. Keep the trough in sunlight. Study the following :

1. **Abiotic components :** (i) Measure the temperature of the pond by a thermometer, (ii) Find the pH of the water by pH papers.
2. **Biotic components :** Study the following :
  - (a) **Producers :** Consisting of green plants. The plants may be submerged such as *Hydrilla*, *Vallisneria*, *Chara* and *Ceratophyllum*. The free floating and rooted floating consist of *Spirodella*, *Wolffia*, *Lemna* and *Nelumbo* respectively. The phytoplankton includes Xanthophyceae and Chlorophyceae.
  - (b) **Consumers :** Consumers are **primary**, **secondary** and **tertiary**. Primary consumers include bottom consumers, insects and zooplankton. Secondary consumers comprise small fish, insects and frogs, while tertiary consumers include big fish and birds.

#### EXERCISE (2)

**Object :** To study the biotic components of a pond ecosystem.

**Requirements :** Collection nets with different mesh sizes, metallic chains with hooks, specimen tubes, glass jars, hand lens, scissors, forceps, hand centrifuge, microscopes and stains.

**Procedure :** Plants and animals from pond could be collected by nets and placed in jars and polythene bags.

Pond water with vegetation could be collected in a glass trough also. Metallic chains and hooks may be used to collect various plants. Planktons (algae and protozoans) are collected by nylon nets. Bring pond water sample to laboratory for further examination.

**Observation :** Observe three biotic components of pond ecosystem namely producers, consumers and decomposers.

1. **Producers :** Comprise following green plants:
  - (a) **Sub-merged :** *Hydrilla*, *Vallisneria*, *Ceratophyllum*, *Chara*.
  - (b) **Free floating :** *Spirodella*, *Pistia*, *Wolffia*, *Eichornia*, *Azolla*, *Lemna*.

(c) **Rooted floating** : *Aelumbo*, *Nymphaea*.

(d) **Amphibious** : *Typh ranunculus*.

(e) **Phytoplankton** : Members of Chlorophyceae, Myxophyceae, Bacillariophyceae and Xanthophyceae.

2. **Consumers** :

(f) **Primary** : Bottom fauna such as molluscs, insects and Zooplankton.

(g) **Secondary** : Small fish insects.

(h) **Tertiary** : Large fishes and birds.

3. **Decomposers** : Bacteria and fungi, especially *Aspergillus*, *Penicillium*, *Fusarium*, *Paecilomyces*, *Rhizopus*, etc.

**EXERCISE (3)**

**Object** : Study of community structure of grassland. Grasslands are present between forests and deserts, and the climate in this region is of the intermediate type. Winters are cold, summers warm and rainfall average. Flora and fauna of the grasslands are as under :

- Study of the flora of grasslands** : Perennial grasses constitute the dominant climax vegetation. Climax grasses may be tall (1.5 to 3 m), medium (0.5 to 1.5 m) or short (below 0.5 m) and grow in bunches. Grasses grow quickly after the onset of warm and rainy weather and are adapted for long quiescent periods of dryness and cold. Leaves or top of the grasses die during unfavourable seasons, but underground kinds regenerate new growth during the next favourable period. Tall and short grasses are observed in a grassland.

Tall and mid grasses	Short grasses
1. <i>Andropogon</i> -Blue stem	1. <i>Aristichia</i> -Triple armed grass
2. <i>Agropyron</i> -Wheat grass	2. <i>Bontelous</i> -Grana grass
3. <i>Elymus</i> -Poric grass	3. <i>Buchli</i> -Buffaloe grass
4. <i>Poa</i> -Blue grass	

**Note** : Collect grasses and make their Herbarium.

- Study of the fauna of grasslands** : Due to presence of grasses in abundance, in grasslands, large populations of grazing animals are present. Large herbivorous ungulates reach their largest population. They feed in large herds. Bison and proghorn antelopes are the main occupants. Predators feeding on these animals, like wolves

and bears, rodents and lagomorphs constitute the other principal groups of mammals. Ground squirrels, pocket gophers, mice and jack rabbits are common nearly everywhere.

**B. Study of Abiotic Factors**

**EXERCISE (4)**

**Object** : To estimate the chlorides and sulphates of calcium for hardness of water.

**Glass apparatus** : Burette, stand, pipette (50 ml graduated), beaker and titration flasks.

**Preparation of reagents**

- Calcium chloride solution** : Dissolve 55 gm of calcium chloride in 1000 cc of distilled water in a titration flask.
- Sodium versnate solution** : Dissolve 2.5 gm of sodium versnate in 2000 cc of distilled water. Add 13.5 cc of 1 N.NaOH (40 gm of NaOH in 1000 cc of distilled water). Make the volume upto 2500 cc. For making it as standard solution, titrate it with Eriochrome Black-T as an indicator.
- Eriochrome Black-T (Standard solution)** : Add 1 gm of Eriochrome Black-T in 30 ml of distilled water. Add to this 1 ml of 1N.Na<sub>2</sub>CO<sub>3</sub>. Make the volume to 100 cc with isopropyl alcohol.
- Buffer solution** : Dissolve 40 gm of borax in 800 ml of distilled water in a beaker. In another beaker, dissolve 10 gm of NaOH and 5 gm of sodium sulphide in 100 ml of distilled water. Mix the two solutions together and make it up to 1000 cc with distilled water.

**Procedure** : (1) Take 100 ml of sample water from any pond, river or lake.

- Add few drops of 0.01 N.HCL to make it acidic.
- Boil it for few minutes.
- Add 0.5 ml of buffer solution.
- Add few drops of Eriochrome Black-T indicator solution.
- Titrate with standard versnate solution. Take initial reading. Then take end point reading on the appearance of blue water.

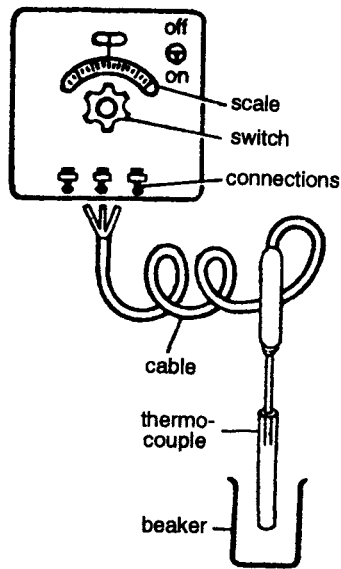

Fig. 2. Thermistor.

(7) Repeat the experiment 5 times.

Amount of sodium versnate used represents 1 part per ml of chlorides and sulphates.

#### EXERCISE (5)

**Object :** To determine pH turbidity, temperature and light intensity.

**Requirements :** pH universal indicator, Secchi disc, long thread, meter scale, thermistor and sealed photometer in water tight containers with glass windows.

**Procedure :**

- pH :** For determining pH of a pond water, collect water of pond from different places and depths. Keep these water samples in different wide mouthed glass stoppered bottles. Mark these bottles according to the place of their collection. Take 5 ml of water of a bottle, add few drops of universal indicator. Compare the colour developed with the colour chart pasted on the indicator bottle and find out approximate pH. Determine pH of all the bottles and make a chart showing place of collection and pH.
- Turbidity :** For determining turbidity, take Secchi rounded discs having white and black stripes. With both hands gradually lower the disc in water whose turbidity is to be

determined. A point would come when white and black stripes would be indistinguishable. This depth of water is referred to as **turbidity index**. Collect water from different ponds for determining turbidity. Note the depth of turbidity index in each case.

- Temperature :** For determining the temperature of the pond, use thermistor (Fig. 2). It consists of a glass globule with thermocouple, electric cord and potentiometer with graduated scale collect pond water in a beaker. Dip the glass globule in beaker holding with hands. Switch on potentiometer and note directly the temperature indicated by the needle. Note the temperature of the pond at different places and at different depths.
- Light intensity :** For determining light intensity, place the sealed photometer at different sites and depths in pond and note directly the reaching of light intensity.

#### EXERCISE (6)

**Object :** To determine dissolved oxygen (DO).

**Requirements :** Titration flasks, titration tube, manganous sulphate solution, Alkali-iodide-azide reagent, concentrated sulphuric acid, phosphoric acid, sodium thiosulphate solution (0.1N and 0.025N), and starch solution.

**Principle :** If manganous sulphate is added to the sample containing alkaline potassium iodide, manganous hydroxide is formed which is oxidised by the dissolved oxygen on addition of sulphuric acid. If further sulphuric acid is added, the basic manganic oxide liberates iodine equivalent to that of dissolved oxygen originally present in the sample. The liberated iodine is titrated with standard solution of sodium thiosulphate using starch as indicator. By calculating the amount of iodine liberated, the DO could be determined.

#### Preparation of reagents

- Manganous sulphate solution :** Take 250 ml titration flask. Weigh 91.0 gm of manganous sulphate monohydrate and dissolve it in titration flask in 9 litres of distilled water. Then dilute with distilled water upto 250 ml mark.

2. **Alkali-iodide-azide reagent** : In a titration flask, dissolve 175 g Potassium hydroxide (OR 125 g sodium hydroxide) and 37.5 g potassium iodide (for 33.7 g sodium iodide) in a little distilled water and dilute with distilled water upto 250 ml.
3. **Sodium thiosulphate solution.** Dissolve 24.82 g sodium thiosulphate in a little double distilled water in a volumetric flask. Dilute with distilled water upto 1000 ml. To make 0.025 N sodium thiosulphate solution, take 250 ml of 0.1 N sodium thiosulphate and dilute it to 1000 ml with double distilled water.
4. **Starch solution** : Take 1 gm starch in a little water. Make a thin paste and pour it in 100 cc boiling water. Keep on boiling for 2 minutes and then cool.

**Procedure** : (1) Collect the sample in BOD bottles.

- (2) Add 2 ml manganous sulphate solution in the bottle by pipette. The pipette should never touch the water level. It should always be above the water level.
- (3) Add 2 ml alkali-iodide-azide solution.
- (4) Close the bottle with stopper and invert the bottle 10 times. A brown precipitate appears indicating presence of oxygen. If white precipitate, no oxygen.
- (5) Allow the precipitate to settle completely.
- (6) Remove stopper carefully and add 2 ml of concentrated sulphuric acid by the sides of the bottle.
- (7) Take 203 ml of the solution from the bottle into a conical flask of 500 ml capacity.
- (8) Titrate immediately with 0.025 N sodium thiosulphate solution using starch as indicator.

**Calculation** : If the thiosulphate solution is exactly 0.025 N, then mg/l dissolved oxygen = ml thiosulphate XI.

#### EXERCISE (7)

**Object** : To determine carbon dioxide (CO<sub>2</sub>).

**Requirements** : Distilled water, sodium carbonate, phenolphthalein, measuring cylinder, conical flask and Zeoondroff apparatus.

**Principle** : CO<sub>2</sub> constitutes basic component of photosynthesis in plants. Without CO<sub>2</sub> hardly

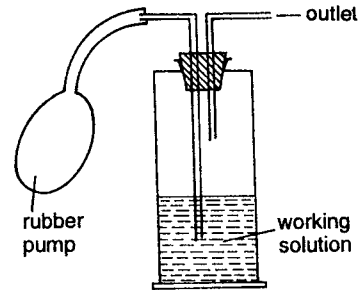

Fig. 3. Zeoondroff apparatus.

any life can exist. Oceans serve as biospheric CO<sub>2</sub> reservoir. Industries created by man and burning fuel increase CO<sub>2</sub>. CO<sub>2</sub> is continuously absorbed by sea but the oceans do not absorb CO<sub>2</sub> at the rate at which it is being produced. Climatologists are of the opinion that small changes in the atmospheric CO<sub>2</sub> bring disturbances in the terrestrial environment.

**Procedure** : Dissolve 0.53 gm of sodium carbonate in 100 ml of distilled water in a conical flask, boil the solution and cool it. Add 0.1 gm of phenolphthalein to the solution. The solution becomes pink. Shake the solution. Take 10 ml of sodium carbonate solution in Zeoondroff apparatus. Keep the apparatus in a normal or benign environment with normal CO<sub>2</sub> concentration on a table. Pump the air through the rubber pump. Count each stroke of pump, till the pink colour disappears.

After disappearance of pink colour, clean the above apparatus thoroughly. Again add 10 ml of working solution to the Zeoondroff apparatus. Take the apparatus where CO<sub>2</sub> is to be measured. Keep the apparatus on a table. Here also pump CO<sub>2</sub> through rubber pump. Count the number of stroke till the pink colour disappears. Calculate percentage of CO<sub>2</sub> by the following formula :

$$\text{CO}_2 (\delta) = \frac{B}{S \times 25}$$

where B = number of strokes applied in benign environment, S = number of strokes applied in polluted area. Thus calculate percentage of CO<sub>2</sub>.



## ANALYSIS OF SOIL

The soil analysis involves physical characters of soil, chemical characteristic and moisture content.

### EXERCISE (8)

**Object :** To study physical characteristics of soil texture, colour and temperature.

**Procedure :**

1. **Texture :** Collect different soil samples. Observe with hand lens. Also examine and observe the soil between thumb and fingers. The following kinds of soils can be observed :
  - (a) **Sandy :** Individual grains (0.02-2.0 mm) are observed, crystal-like structure. Moist sands are squeezed.
  - (b) **Sandy loam :** Dry grains fall separate. Moist form does not break and forms casts.
  - (c) **Loam :** Can be squeezed when dry. Moist soil forms casts and can be easily handled without breaking.
  - (d) **Silt loam :** Dry as well as moist soils can be easily handled without breaking. Grain size 0.02-0.2 mm.
  - (e) **Clay loam :** Hard when dry. Breaks into lumps. Moist soil is pinched forming thin ribbon which breaks easily.
  - (f) **Clay :** Forms a very hard lump when dry. Moist and wet soil sticky. Size of soil particles 0.002 mm.
2. **Colour :** Collect soil samples and spread over a cardboard or white paper sheet. Spread the particles of the soil. Match the colour of different particles with Munsell's colour chart. Note different colours of the soil particles.
3. **Temperature :** Special thermometer, called **soil-thermometer**, is used to measure the temperature of different soils by inserting the bulb of thermometer in soil. Temperature can also be taken from different depths. Dig the soil at different depths such as 1, 6, 12 and 18 inches.

### EXERCISE (9)

**Object :** To study chemical characteristic of the soil.

The pH, moisture content, nitrate and carbonate contents of the soil could be studied.

**Requirements :** Different soil samples, hot oven, china clay, tiles, test tubes, capillaries, universal indicator, barium sulphate, hydrochloric acid, diphenylamine, concentrated sulphuric acid, ammonium thiosulphate solution and hydrogen peroxide.

**Procedure :**

1. **pH value :** For determining pH of the soil collect the sample of the field. Take small amount of soil in a test tube. Weight the soil and add equal amount of barium sulphate. Add 15 ml of water. Stir the soil and then allow the solution to stand for sometime. Take few drops of the supernatant fluid in a watch glass. Add equal amount of universal indicator in the watch glass. Match the colour of the fluid with colour chart for different pH values on indicator bottle. Note the pH value. Detect pH of different soil samples.
2. **Moisture content of the soil :** For determining moisture of the soil, collect moistured soil, weight and then keep in hot oven at a temperature of 105-110°C, for 24 hours. Weight the sample. Calculate the moisture percentage by the following formula :
  - (i) Weight of the soil before heating = X gm
  - (ii) Weight of the soil after heating = Y gm
  - (iii) Moisture present = X - Y gm
  - (iv) Moisture percentage =  $\frac{X - Y}{Y} \times 100$
3. **Carbonate content of the soil :** For determining carbonates, take the samples of the soil in different test tubes. Add few drops of hydrochloric acid in each test tube. Effervescence occurs. The degree of effervescence varies in different test tubes. The tubes showing maximum effervescence indicates maximum carbonates in the soil.
4. **Nitrate content :** For determining nitrates, take 1 gm of each soil sample and mix it with 5 ml of water. By a pipette take small amount of each sample in a white plate or glass plate. To each sample add 2-3 drops of diphenylamine and 2 drops of concentrated sulphuric acid. Blue colour develops. The intensity of the colour varies in different sample tests.

# Experimental Endocrinology

# 17

These days study of endocrine glands has become important in view of their role in various functions of the body. Large number of functions are governed by hormones. Basic practical work for a beginner student of endocrinology involves :

- (1) Dissection and exposure of major endocrine glands in an experimental animal such as **Black rat** (*Rattus rattus*) or **Albino rat**.
- (2) Study of various histological slides of the major endocrine glands of mammals or birds.

## DISSECTION OF ENDOCRINE GLANDS

**Procedure :** For exposing endocrine glands of Rat :

- (1) Kill the rat with chloroform.
- (2) Immerse the rat in an antiseptic solution such as dettol or savlon.
- (3) Wash the rat. Lay it in a dissecting dish. Fix the rat with pins with abdomen facing yourself.
- (4) Make a longitudinal slit in the skin of the abdomen from the pubic symphysis to the tip of snout.
- (5) Make the transverse cuts at the ends of longitudinal cut.
- (6) Separate the flaps of skin from the muscular body wall.
- (7) Expose various endocrine glands, with the help of the practical book, at their respective positions. For pituitary, break cranium from sides and expose the gland at the base of cerebellum. Various glands are as under :

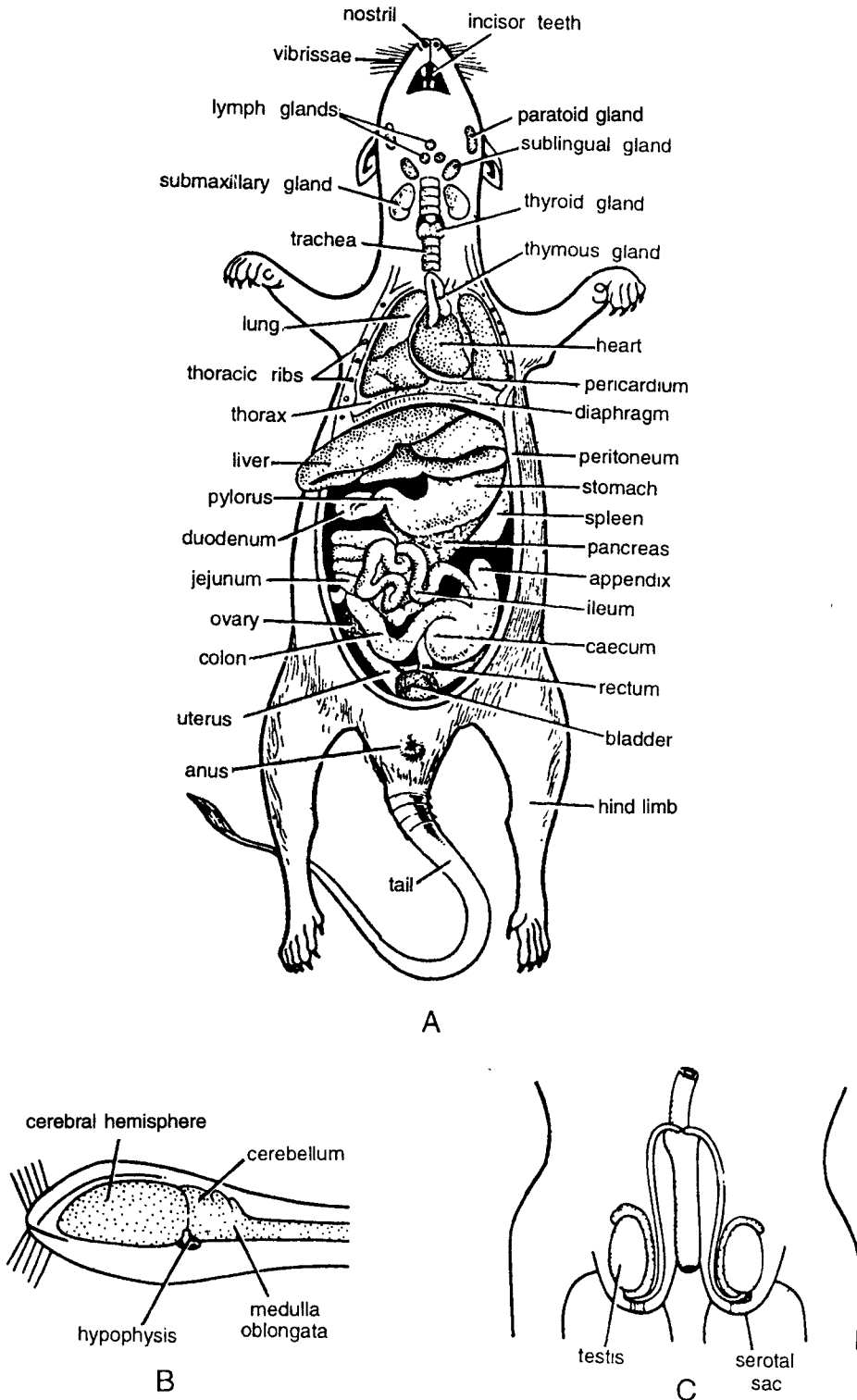

Fig. 1. Rat : A. Endocrine glands, B. Pituitary gland in cranium, C. Testis in scrotal sac.

## Endocrine Glands : Location

Locate the following endocrine glands after dissecting the rat.

- (1) **Pituitary gland.** The pituitary gland or hypophysis is a small rounded gland located ventrally in the **sphenoid** and attached to hypothalamus by a slender stalk. Pituitary contains two lobes. The anterior lobe is pinkish and made up of glandular tissue while posterior lobe is whitish and fibrous.
- (2) **Thyroid gland.** Found at the root of the throat practically over the middle of the trachea. It is made up of two lobes present on either side of the trachea. The two lobes are joined together by **Isthmus**.
- (3) **Parathyroid gland.** There are two small rounded parathyroid glands found embedded in the posterior surface of each lobe of thyroid gland.
- (4) **Adrenal gland.** A pair of glands, each present on the dorsal curvature of each kidney. Adrenal glands are yellowish or brownish.
- (5) **Testis.** One pair of testes which could be easily located inside scrotal sacs. Cut open the scrotal sacs and 2 rounded testes could be easily seen, one in each sac.
- (6) **Ovary.** Two ovaries located just beneath the kidney.
- (7) **Pancreas.** Pancreas is both exocrine as well as endocrine gland. Hormones insulin and glucagon are secreted by islet of Langerhans found in pancreas. It is an irregularly branched pinkish gland held by mesentery in the U-shaped duodenal loop.
- (8) **Thymus gland.** Two lobed glands are found above the heart in rat between breast bones on both sides of lungs. Thymus is both **lymphoid** as well as **endocrine gland**. In birds (chick), thymus is a paired structure consisting of seven ovoid lobes found in the neck along the gut. It is found in the sub-dermal connective tissue originating near third cervical vertebrae and extending posteriorly upto thyroid gland.

## HISTOLOGY OF ENDOCRINE GLANDS

The histological details of various endocrine glands can be studied from permanent prepared slides as under.

### 1. Rat : L.S. of Pituitary Gland

**Comments :** In a L.S. of pituitary (hypophysis), the following structures are seen :

- (1) A small portion called as **pars tuberalis** extending upwards from anterior lobe, connecting hypophysis with hypothalamus.
- (2) On the basis of cell types, hypophysis is divided into the anterior lobe or **adenohypophysis** and posterior lobe or **neurohypophysis**.
- (3) Adenohypophysis contains 3 parts, namely : (i) **pars distalis**, (ii) **pars tuberalis** and (iii) **pars intermedia**.
- (4) Adenohypophysis is composed of **chromophere cells**, **acidophil** or **oxyphil cells** and **basophil cells**.
- (5) Neurohypophysis is composed of 3 parts, namely **pars nervosa**, (ii) **infundibulum** and (iii) **median eminence**.
- (6) Pars nervosa is made up of **ependymal cells**, mossy neuroglial cells and pituicytes which secrete pituitary hormones.

**Special features :** Pituitary controls other endocrine glands and is called as **Master gland**. Various hormones of **adenohypophysis** are : somatotrophic hormone (SH), thyrotropic (TH), adenocorticotrophic hormone

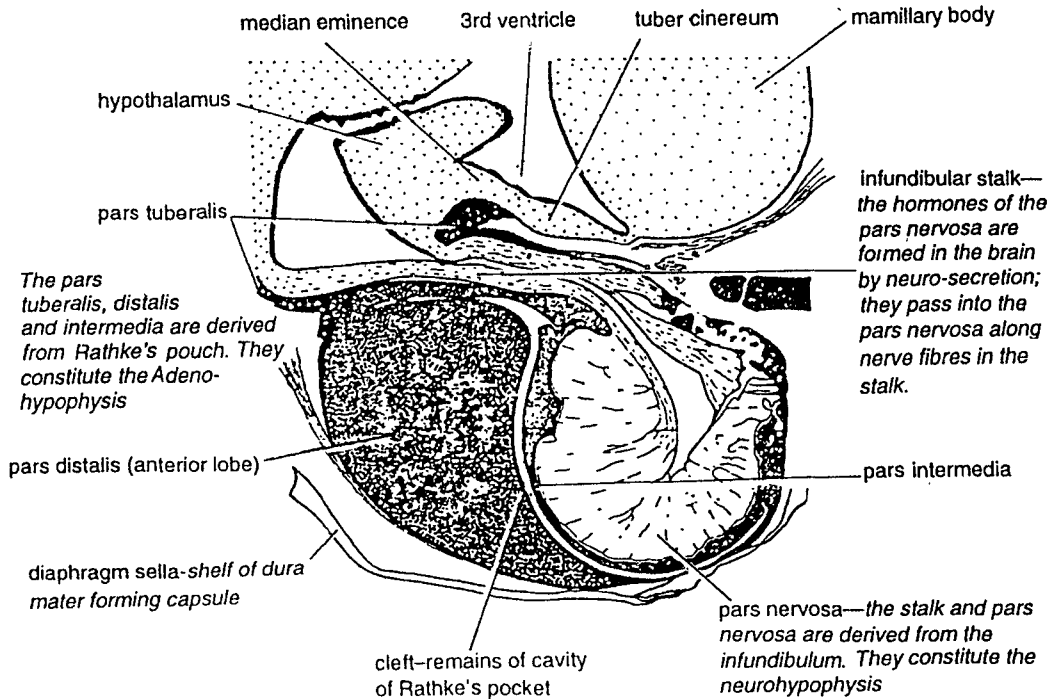

Fig. 2. Rat : L.S. Pituitary gland.

(ACTH), gonadotropic hormones (FSH, CSH and LH), prolactin hormone (PH) and melanocyte stimulating hormone (MSH); **neurohypophysis hormones** and vasopressin, oxytocins and antidiuretic hormone (ADH).

**Identification :** Since the section contains hypophysis and above features, hence it is L.S. of **pituitary glands** of rat.

## 2. Rat : T.S. of Thyroid Gland

### Comments :

**A. Under low magnification :** (7 X eyepiece; 4 X objective).

- (1) It is the most familiar endocrine gland, consisting of right and left lobes connected across to the ventral side of trachea by isthmus.
- (2) **Thyroid gland** comprises of a framework of connective tissue, enclosing numerous rounded or **oval follicles** or vesicles of different size.
- (3) Histologically it consists of a number of rounded **thyroid follicles** of various sizes, separated by one another by **connective tissue** strands.
- (4) Thyroid is richly supplied with blood vessels and nerves. It is innervated from the **sympathetic nerves**.
- (5) Thyroid secretes **thyroxin** ( $C_{15}H_{11}O_4N_14$ ) which contains an amino acid and 65% of iodine.

**B. Under high magnification :** (10 X eyepiece; 40 X objective).

The **thyroid** is composed of **follicular** and **interfollicular** zones. Follicles are surrounded by single layered cubical or rounded epithelial cells. Lumen of each follicle contains a viscous liquid called as thyroid

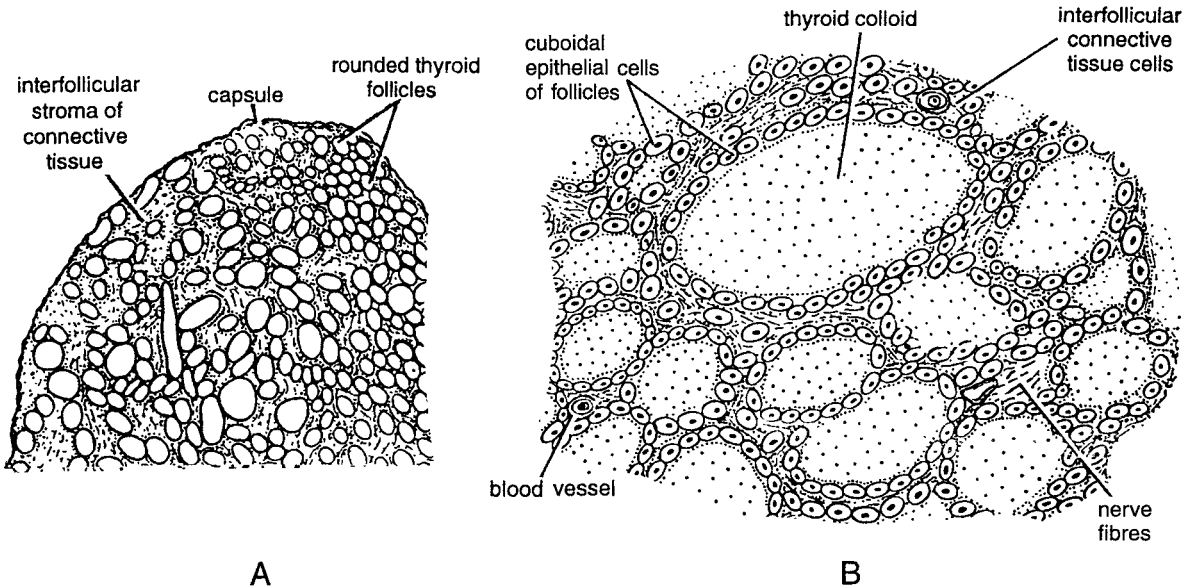

Fig. 3. Rat : T.S. of thyroid gland : A. Under low magnification, B. Under high magnification.

**colloid.** Interfollicular zone contains connective tissue cells, nerves, blood vessels and large number of nuclei.

**Special features (functions) : Thyroxin** controls entire **metabolism**. Its deficiency causes lowered metabolism.

**Hyperthyroidism** results in protrusion of **eye-balls**. Removal of thyroid from the frog tadpole stops metamorphosis. Thyroid gland is controlled by Thyroid Stimulating Hormone : TSH from pituitary.

**Identification** : Since the section contains thyroid follicles and above features, hence it is T.S. of **thyroid gland of rat**.

### 3. Rat : T. S. of Parathyroid Gland

**Comments :**

- (1) Two **parathyroid** glands are always found embedded in the substance of thyroid or found on each side of the thyroid gland.
- (2) Each parathyroid is enclosed within a capsule.
- (3) Each parathyroid is a glandular organ consisting of columns of epithelial cells.
- (4) The gland contains **chief cells**, **colloid** or **oxyphil cells**, separated by the connective tissue.
- (5) Parathyroid produces a hormone called as **parathormone**, which is devoid of iodine.
- (6) Removal of parathyroid causes **tetany** or **death**.
- (7) Numerous sinusoid blood channels run between the columns.
- (8) Parathyroid gland develops as epithelial outgrowth from the third and fourth branchial clefts of the embryo.

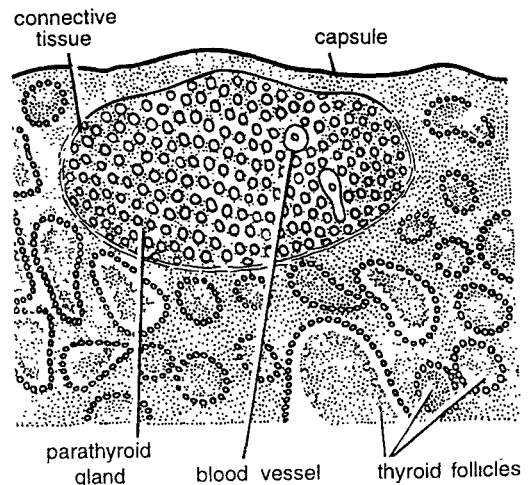

Fig. 4. Rat : T.S. of parathyroid gland.

**Identification :** Since the section contains column of epithelial cells and above features, hence it is T.S. of parathyroid gland of rat.

#### 4. Rat : T.S. of Adrenal Gland

**Comments :**

**A. Under low magnification (7 X eyepiece; 4 X objective)**

- (1) **Adrenal glands** lie at the anterior end of kidneys and are two in number.
- (2) T.S. passing through the adrenal gland shows that it is composed of outer, yellow coloured **cortex** having vertical striations and inner soft, highly vascular and dark brown **medulla**.

**B. Under high magnification (10 X eyepiece; 40 X objective)**

- (3) The entire gland is covered by fibrous capsule which sends septa into the cortex and divides it into 4 zones.

- (a) **Zona glomerulosa** : This zone is found below the capsule. It comprises of columnar cells. This zone controls the mineral and water balance of the body and also fat and carbohydrate absorption. Active hormone is **deoxycorticosterone** which is not under pituitary control.
- (b) **Zona fasciculata** : This zone consists of compressed cells which secrete **corticosterone** to control carbohydrate metabolism. This hormone also causes disintegration of lymphocytes and release of their antibodies.
- (c) **Zona reticularis** : Next to medulla, this zone consists of pigmented reticular cells. This zone secretes sex hormones.
- (d) **X-zone** : Sometimes, as is in young mice, there is an extra zone between zona reticularis and medulla.

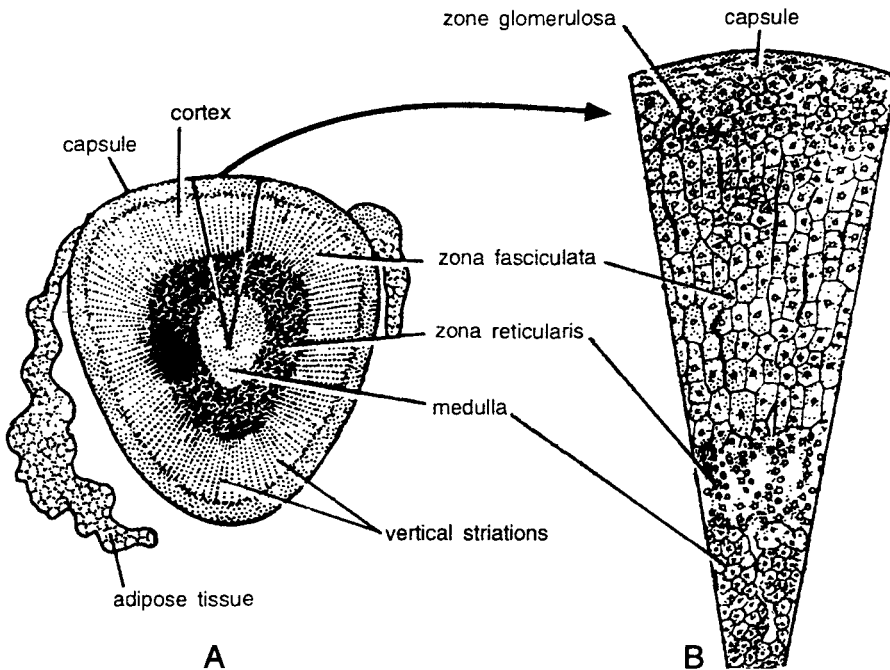

**Fig. 5.** Rat : T.S. of adrenal gland : **A.** Under low magnification, **B.** Under high magnification.

- (4) Medulla has irregularly disposed cells.
- (5) It contains elastic fibres and sinusoids (large blood spaces).
- (6) Medulla cells have granular cytoplasm which take dark stain with osmic vapour.
- (7) In some medulla cells are **chromoffin bodies** or paraganglia.
- (8) Cortex has mesodermal origin and medulla neuroectodermal and have abundant blood supply.

**Special features (functions) :** Adrenal gland secretes important hormones both from medullary and cortical zones. The medullary hormones are **Epinephrine (Adrenaline)** and **Norepinephrine**. Epinephrine is hypoglycemic hormone, promotes **glycogenolysis** and increases blood pressure. The cortical region secretes corticoids which promote **glyconeogenesis** and marked effect on **protein metabolism**.

**Identification :** Since the section contains cortex, medulla and above features hence it is T.S. of **adrenal gland of rat**.

### 5. Rat : T.S. of Testis

**Comments :**

**A. Under low magnification :** (7 X eyepiece; 4 X objective).

- (1) There is a pair of smooth; oval-shaped testes, each enclosed in a thin envelope, called as **tunica albuginea**.
- (2) Histologically each **testis** is internally divided into a number of lobules with occasional internal communications and separated by connective tissue.
- (3) Glandular substance of the testis is wholly made up of convoluted **seminiferous tubules**. Large number of cut seminiferous tubules are seen with varying diameter.
- (4) Interseminiferous tubular tissue is formed by connective tissue, binding the tubules together.
- (5) In the connective tissue are rounded interstitial cells which produce a hormone, called as **testosterone**. Testosterone is responsible for the development of male **secondary sexual characters**.

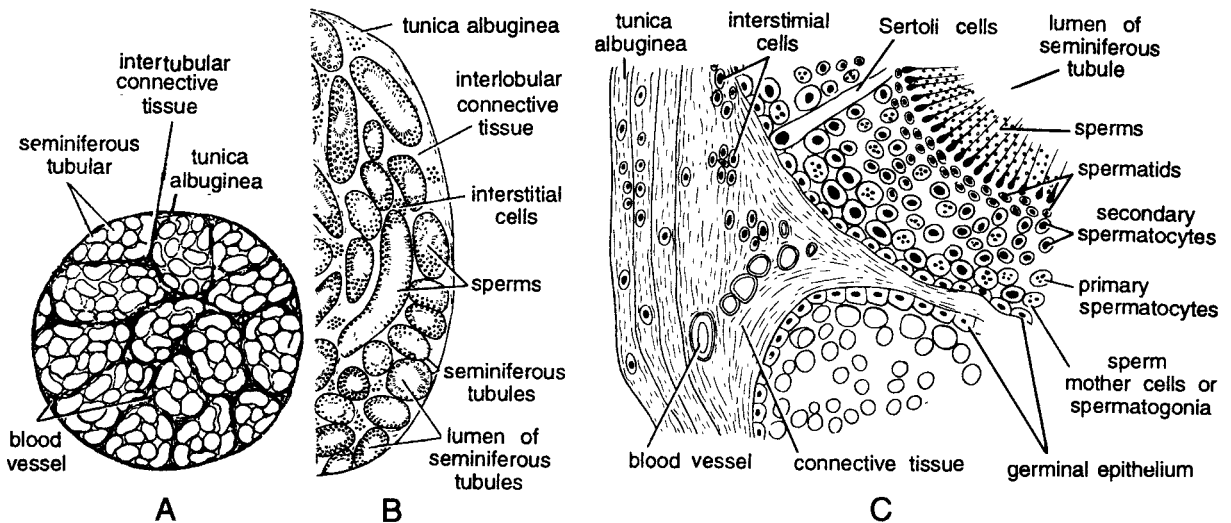

**Fig. 6.** Rat : T.S. of testis : **A.** Under low magnification, **B.** Half of testis under low magnification, **C.** Under high magnification.



**B. Under high magnification :** (10 X eyepiece; 40 X objective).

- (1) **Testis** is covered by a tough fibrous cellular layer with outer envelope of serosa. The fibrous coat encloses various seminiferous tubules.
- (2) At the interjunction of two seminiferous tubules, connective tissue, interstitial cells and vacuoles are seen.
- (3) In the seminiferous tubules are some nutritive **cells of Sertoli**.
- (4) Seminiferous tubules appear rounded or oval in section. Each tubule is surrounded by a thin basement membrane lined by germinal epithelium.
- (5) From basement membrane to inwards there are several kinds of cells :
  - (i) **Spermatogonia** lie along periphery of tubule and appear closely packed together.
  - (ii) **Primary spermatocytes** : They have the largest cells and large nuclei.
  - (iii) **Secondary spermatocytes** : Smaller cells with deeply stained nuclei.
  - (iv) **Spermatids** : Small clusters of cells with condensed nuclei.
  - (v) **Spermatozoa** or sperms lie in the cavity of the tubule.
- (6) Sperm has head and tail.
- (7) The nucleus of the sperm lies in the head which is pointed as the acrosome.

**Identification :** Since the section contains semeniferous tubules and above features, hence it is T.S. **Testis of Rat**.

## 6. Rat : T.S. of Ovary

**Comments :**

**A. Under low magnification :** (7 X eyepiece; 4 X objective).

- (1) **Ovary** is a solid structure lying at the back of the peritoneal cavity. It is covered by peritoneum consisting of cubical cells, forming germinal epithelium. **Ovary** is attached at the hilus by **mesovarium** with the uterus. Germinal epithelium is bounded by connective tissue, called as **tunica albuginea**.

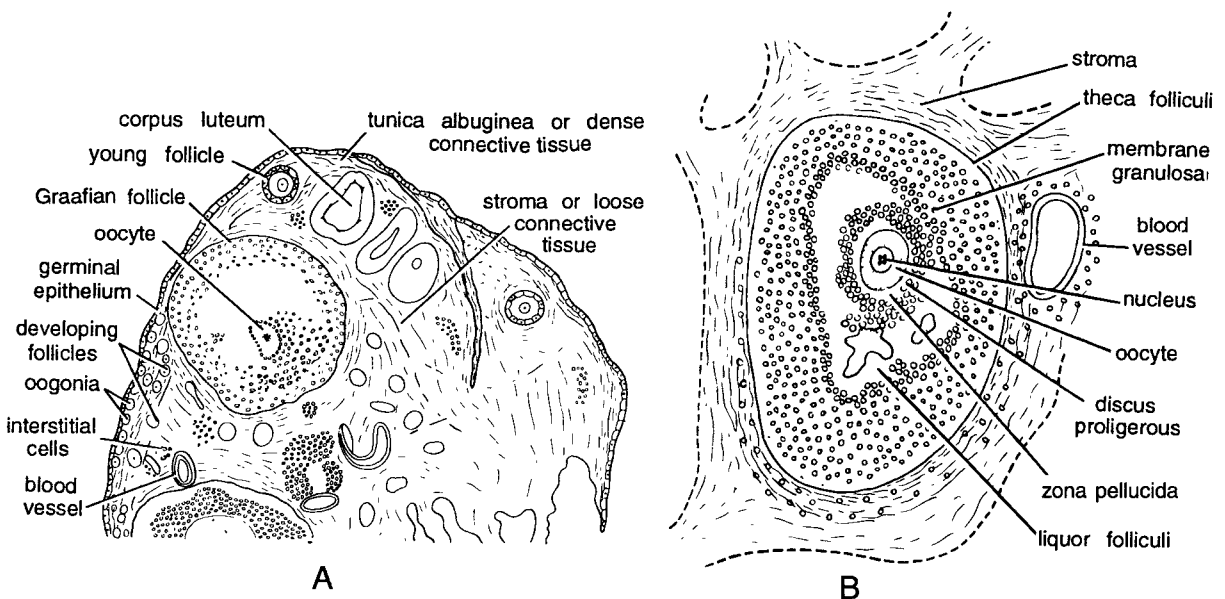

**Fig. 7. Rat : T.S. of ovary : A. Under low magnification, B. Under high magnification.**

- (2) **Hilus** is characterised by having helicine arteries. Several primary oocytes are seen beneath germinal epithelium. Mature follicle is called as **Graafian follicle**. All the structures lie in ovarian stroma which is made up of connective tissue, fibroblasts, collagen, reticular fibres, nerves, blood vessels and lymphatics.

**B. Under high magnification :** (10 X eyepiece; 40 X objective).

- (1) T.S. passing through ovary or Graafian follicle shows following important structures.
- (2) Each Graafian follicle is made up of a **wall**, called as **theca folliculi** consisting of ovum and epithelium.
- (3) In the smallest follicle ovum is single layered; in large ones it has 2 layers while in still larger ones the 2 layers are formed by several strata of cells.
- (4) Cells lining the cavity of the follicle are termed **membrana granulosa**, while the mass of cells surrounding immediately ovum are called **cumulus** or **discus proligerous**.
- (5) Fully mature oocyte is surrounded by the thick transparent membrane, called as **zona pellucida**, which is covered by another layer, **corona radiale**.
- (6) **Zona pellucida** contains yolk and fat droplets.
- (7) After the extrusion of ova, a yellowish mass is left, called as **corpus luteum**, which produces a hormone called **progesterone**. It facilitates the implantation of the fertilized ovum in the uterus and it also inhibits ovulation during pregnancy.
- (8) Regression of **corpus luteum** leads to the formation of **corpus albicans**. Column of luteal cells shows degenerative changes with the appearance of the globules and collagen fibres.

**Special features (functions) :** Ovary produces ova and the entire physiology of ova production is dependent upon two gonadotropic hormones - FSH and LH (follicle stimulating hormone) and LH (luteinizing hormone). FSH stimulates the development and maturation of ovarian follicles. LH stimulates the development of corpus luteum which in turn secretes progesterone.

**Identification :** Since the section contains Graafian follicle and above features, hence it is T.S. of **ovary of rat**.

## 7. Rat : T.S. of Pancreas

**Comments :**

**A. Under low magnification :** (7 X eyepiece; 4 X objective).

- (1) Pancreas is a very important digestive gland. T.S. passing through pancreas shows that it is composed of various **alveoli** or **acini**. It is a compound tubulo-alveolar racemose gland consisting of both exocrine and endocrine parts.
- (2) The mammalian pancreas can be distinguished from that of frog in having distinct lobulation, **alveoli** or **pancreatic acini** and **islets of Langerhans**. Pancreas is covered with **coelomic epithelium**.
- (3) Under low magnification several rounded **acini** and elliptical areas of **islets of Langerhans** are seen.
- (4) Each pancreatic lobe contains 10-20 secretory cells which are nucleated. The central part has narrow to wide lumen. The pancreatic duct, large artery and vein are also seen in the section. Several cut blood capillaries are present.
- (5) Several scattered groups of cells called as islets of Langerhans, which are somewhat paler, are distinctly seen.

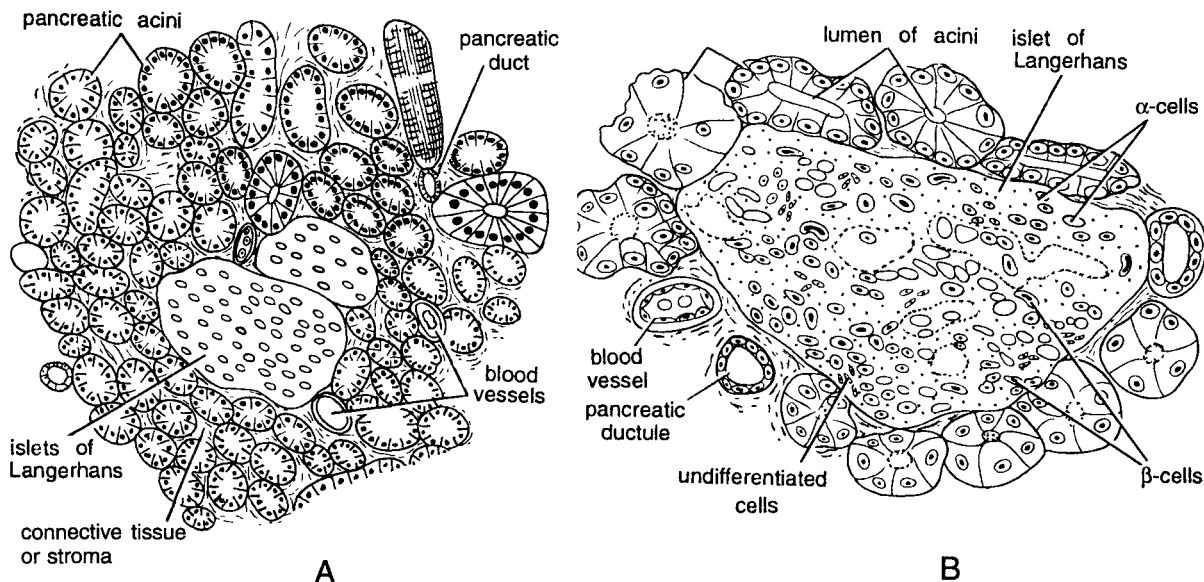

Fig. 8. Rat : T.S. of pancreas : A. Under low magnification, B. Under high magnification.

**B. Under high magnification :** (10 X eyepiece; 40 X objective).

- (1) **Serosa** is made up of simple **squamous** or cuboidal epithelium.
- (2) Acini and islets of Langerhans are very clearly seen. The wall of each acinus is made up of columnar or **pyramidal cells**. Each cell contains a central nucleus and coarse granules. Each acinus has wide lumen.
- (3) The region of islet of Langerhans reveals 3 or 4 kinds of cells -  $\alpha$ ,  $\beta$  and **undifferentiated cells**.

**Special features (functions) :** Endocrine islets of Langerhans, in eosin-haematoxylin-stained sections, appear as rounded masses of cells with unstained cytoplasm and they contain 3 kinds of cells :

- (a) **Alpha cells** ( $\alpha$ -cells) which secrete a **hormone** called as **glucagon**. It increases blood sugar level in the body and its deficiency causes **hypoglycemia**.
- (b) **Beta cells** ( $\beta$ -cells) secrete another hormone, **insulin**, which plays an important role in **carbohydrate metabolism**. Its deficiency causes diabetes. It regulates blood sugar level.

**Identification :** Since the section contains islet of langerhans and above features, hence it is T.S. of **pancreas of rat**.

## 8. Chick : T.S. Passing Through Thymus Glands

- (1) T.S. Passing through the thymus gland shows that it is composed of (i) capsular wall, (ii) cortex and (iii) medulla.
- (2) The outermost wall enclosing thymus gland is called as **capsular wall**.
- (3) **Cortex** contains large number of small and rounded **lymphocytes** and reticular cells.
- (4) **Medulla** also contains several rounded thymocytes or lymphocytes and thymic corpuscles of unknown function.

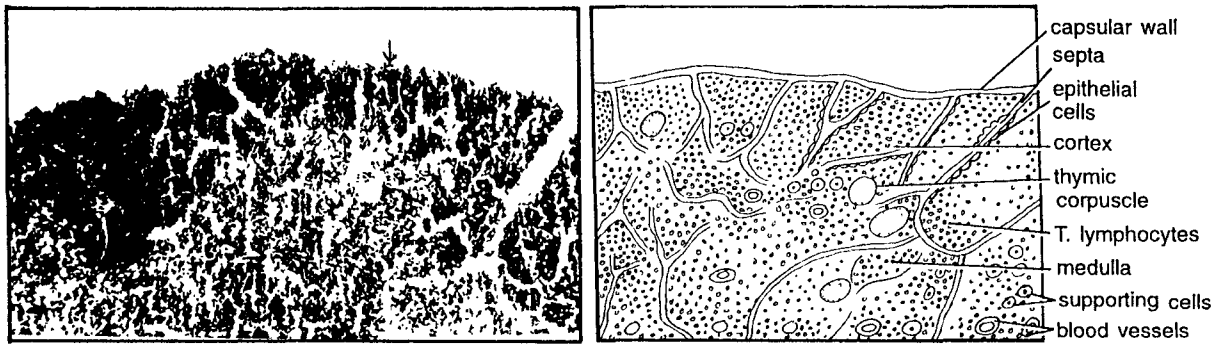

Fig. 9. Chick : T.S. of thymus gland : A. Microphotograph, B. Hand drawn.

- (5) The corticosteroid resistant mature **T. lymphocytes** which are responsible for expressing class I molecules.
- (6) Lymphocytes are surrounded by epithelial cells, supporting cells and reticular cells.
- (7) Epithelial cells produce thymic hormones such as thymosine  $\alpha$ , thymosine  $\beta_4$  and thymopoietins. These hormones play important role in differentiation of CD4 cell and CD8 cell lymphocytes.
- (8) CD4 and CD8 lymphocyte cells play important role in humoral and cell mediated immunity respectively.

**Identification :** Since the section contains cortex, medulla and above features, hence it is T.S. of **thymus gland of chick**.

Evolution is a well established process both in case of animals and plants. Process of evolution is supported by **theories** of evolution and **evidences** of evolution. Various evidences from Comparative Anatomy, Taxonomy, Homology, Analogy, Developmental biology, Palaeontology, Physiology, Genetics, Molecular biology give support to process of organic evolution.

So far evolution has been the subject of theory courses. Practical on evolution have been incorporated in this book for the first time.

Practicals on evolution consists of :

- (A) Study of Evolution of Horses through models,
- (B) Study of Homologous organs or forms and
- (C) Study of Analogous forms.

### **A. STUDY OF EVOLUTION OF HORSE THROUGH VARIOUS MODELS**

Present day modern horses *Equus* are most useful domesticated animals. Horses have gradually evolved. The evolution of horse can be studied through various geological periods such as Eocene, Oligocene, Myocene and Pleistocene. Gradual important changes in various pedigree of horses consists of (i) increase in size (ii) lengthening of

distal portion of legs (iii) reduction of accessory digits (iv) relative increase of front part of skull (v) increase of depth of teeth (hypsodonty) and grinding part of molars and (vi) approximation of pre-molars to molars and completion of post-orbital bar. Evolution of horse can be studied through various models.

## 1. *Hyracotherium* : Model

**Geological event :** The first horse belonged to coenozoic era of tertiary period and eocene epoch about 54 million years ago.

**Geographical conditions :** Tertiary period was marked by separation of continent and rise of mountains in Asia, Europe and western north America with emergence of temperate grass lands, forests and higher plants.

**Distribution :** *Hyracotherium* was found in North America where they became extinct.

**Comments :**

- (1) Size of first horse was very small (Fig. 1/1).
- (2) Body was divisible into **head, neck, trunk and tail**.
- (3) Neck was raised upwards.
- (4) Fore limbs contained 4 **toes**.
- (5) Hinder premolars were molar like.

**Identification :** Since above horse contains 4-toes and above features hence it is model of *Hyracotherium*.

## 2. *Eohippus* : Dawn Horse : Model

**Geological event :** *Eohippus* evolved from *Hyracotherium*. Second horse in evolutionary line was present in coenozoic era of tertiary period and eocene epoch about 54 million years ago.

**Geographical conditions :** Same as in *Hyracotherium*.

**Distribution :** Fossils of above horse were collected from north America.

**Habit and habitat :** *Eohippus* lived in forests feeding on soft vegetation (Fig. 1/2).

**Comments :**

- (1) Commonly called as **Dawn horse**.
- (2) Size of above horse increased measuring about 12 inches. It looked like smaller dog and cat.
- (3) Body was divided into **head, neck, trunk and tail**.
- (4) Head contained elongated jaws, eyes and ear. Back was arched and flexible.
- (5) Forelimbs contained 4 **toes**. First toe was splint and flat.
- (6) Hind limb contained 3 **toes**. Third toe was elongated.
- (7) Premolars were unlike molars.

**Identification :** Since the above horse contains splint and possess above features, hence it is model of *Eohippus*.

## 3. *Mesohippus* : Model

**Geological event :** *Mesohippus*. The third horses were found in south Dakota in coenozoic era of tertiary period and oligocene epoch about 38 million years ago.

**Geographical conditions :** Same as in *Hyracotherium*.

**Distribution :** *Mesohippus* migrated to old world where they became extinct.

**Habit and habitat :** *Mesohippus* was browser feeding on soft vegetation and living in forest.

**Comments :**

- (1) Size of above horse increased (Fig. 1/3).
- (2) Body was divided into **head, neck, trunk and tail**.
- (3) Both forelimbs and hind limbs possessed functional toes. Central toe was longest. They walked on ground 3 toed horse.

- (4) Head contained eyes, ears and horse like jaws.
- (5) Premolars became molar like i.e. molarised.
- (6) Inner cusps were still separated teeth were low crowned.

**Identification :** Since above horse possessed molarized premolars and above features hence it is model of *Mesohippus*.

#### 4. *Parahippus* : Model

**Geological event :** *Parahippus* horses were abundant in coenozoic era of tertiary period and miocene epoch about 35 million years ago and then they became extinct.

**Geographical conditions :** Same as in *Hyracotherium*, but luxuriant grasses were abundant.

**Habit and habitat :** *Parahippus* revealed beginning of adaptations for life on plains and it initiated **running pasture**. Later it became extinct.

#### Comments :

- (1) *Parahippus* further increased in size and weight.
- (2) Body was divided into **head, neck, trunk and tail**. 3 toed horse (Fig. 1/4).
- (3) Second and fourth lateral digits still carried hoofs. Central phalanx was very much elongated and strongest.
- (4) The lateral digits provided support by touching uneven ground to maintain balance.
- (5) Teeth were still low but started elongating and showing cement on crowns.

**Identification :** Since above animal had elongated central phalanx and above features hence it is model of *Parahippus*.

#### 5. *Merychippus* : Model

**Geological event :** *Merychippus* evolved in coenozoic era of tertiary period and eocene epoch about 26 million years ago. Later they became extinct.

**Geographical conditions :** Same as in *Hyracotherium*.

**Distribution :** *Merychippus* was found in North America.

**Habit and habitat :** *Merychippus* existed in great plains and was very successful horse grazing on luxuriant ground vegetation and grasses.

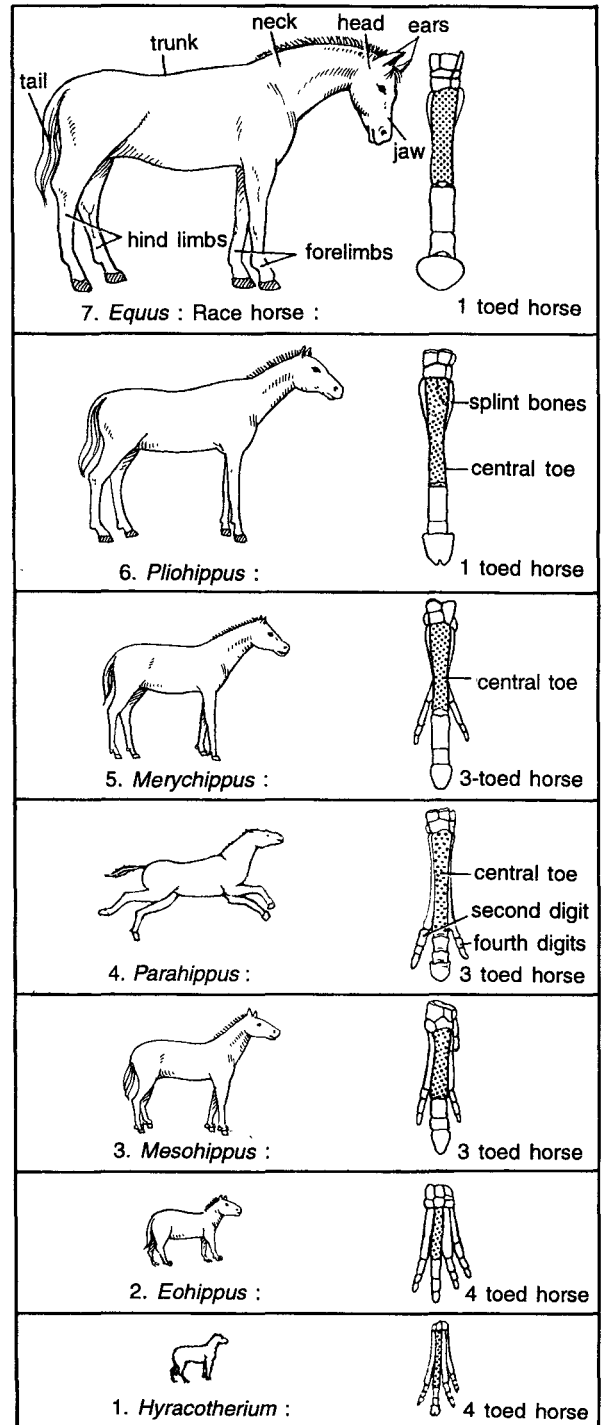

Fig. 1. Evolution of Horse.

**Comments :**

- (1) Size of the horse further increased and it was like present day donkey **3 toed horse**.
- (2) Body was divided in **head, neck, trunk and tail**.
- (3) Head contained eyes, ears and modern horse like jaws (Fig. 1/5).
- (4) Lateral digits shortened to stumps.
- (5) Both fore and hind limbs contained 3 toes. Middle toe contained hoof.
- (6) Depth of the teeth increased.
- (7) High crown with some cusps developed and teeth were cemented.

**Identification :** Since the size of above horse is like donkey and it contains above features hence it is model of *Merychippus*.

### 6. *Pliohippus* : One Toed Horse : Model

**Geological event :** *Pliohippus* evolved from *Merychippus* in coenozoic era of quaternary period in pliocene epoch nearly 7 million years ago. Later they became extinct.

**Geographical conditions :** Same as in *Hyracotherium*.

**Distribution :** Earlier found in North America but when land connections were established they migrated to South America where they became extinct.

**Habit and habitat :** *Pliohippus* was perfect grazer and well adapted for fast running.

**Comments :**

- (1) Size of horse increased to 50 inches tall and it was first **one toed horse**.
- (2) Body was divisible into **head, neck, trunk and tail** (Fig. 1/6).
- (3) Head contained horse like jaws.
- (4) Lateral digits were completely lost by pliocene epoch.
- (5) Fore and hind limbs contained only third toe. Other toes were present as vestigial splint bone.
- (6) Teeth were longer with cusp and were heavily cemented.

**Identification :** Since the above horse contains one toe and above features, hence it is model of *Pliohippus*.

### 7. *Equus* : Modern Race Horse

**Geological event :** *Pliohippus* stock of North America finally reduced the lateral metapodials and became **one toed horse**. *Equus* evolved in coenozoic era of quaternary period of pleistocene epoch approximately 3 million years ago.

**Geographical conditions :** Land connections with luxuriant grasses and ground vegetation were present.

**Distribution :** Cosmopolitan. Modern horse (*Equus*) is found all over the world.

**Habit and habitat :** *Equus* in perfect grazer and fastest runner.

**Comments :**

- (1) Size of the horse increased considerably measuring 60 to 65 inches in height.
- (2) Stoutly built body is divisible into **head, neck, trunk and tail** (Fig. 1/7).
- (3) Head contains eyes, ears and elongated characteristic jaws.
- (4) Teeth are specialized and adapted for grazing and grinding silicons grasses.
- (5) Neck is long mobile. Mane is longer and pendant. Trunk is large.
- (6) Both fore and hind limbs each contained hoofed toe.
- (7) *Equus* is successfully flourishing. It is best domesticated animal used for war, transportation, racing and horse riding.

**Identification :** Since the above horse contains one toe each in fore and hind limbs and above features, hence it is *Equus*.



## B. STUDY OF EVOLUTION THROUGH HOMOLOGOUS AND ANALOGOUS ORGANS AND FORMS

Homologous and analogous organs and forms give evidence for the process of evolution. Homologous organs are those organs which have common origin but perform different functions. Analogous organs and forms are those animals have different origin but having same functions.

### Homologous Organs

The forelimbs of *Talpa* (Mole) bat, monkey, gibbon, whale and horse are homologous organs because in these animals forelimbs are adapted for different functions.

### 8. *Talpa* : Mole

#### Classification :

Phylum.....	Chordata	→	Dorsal tubular nerve cord, notochord and gill-slits present.
Group.....	Craniata	→	Definite head. Cranium with brain present.
Sub-phylum.....	Vertebrata	→	Vertebral column present.
Division.....	Gnathostomata	→	Jaws and paired appendages present.
Super-class.....	Tetrapoda	→	Paired limbs, lungs, cornified skin and bony skeleton.
Class.....	Mammalia	→	Body covered with hairs. Females have mammary glands.
Sub-class.....	Theria	→	Viviparous mammals.
Infra-class.....	Eutheria	→	Placental mammal. Vagina single.
Order.....	Insectivora	→	Feed on insects.
Genus.....	<i>Talpa</i>		

**Geographical distribution :** *Talpa* is found in India (Assam) and the western Himalayas. Cretaceous to Recent.

**Habit and habitat :** It is adapted for subterranean burrowing and lives in tunnels. It feeds on small worms, insects and sprouted seeds. It runs deeper into tunnels.

#### Comments :

- (1) Commonly called as mole.
- (2) **Pigmentation** is uniformly velvet-black, with a silver-grey glossy texture.
- (3) Body measuring 15 cm in length, divided into **head**, **short neck**, **trunk** or back and abdomen.
- (4) **Head** wedge-shaped. **Snout** elongated having prenatal bone. Snout contains **bristles** or vibrissae at the tip.
- (5) **Eyes** are very much reduced and covered with skin. **External ears (pinnae) absent.**
- (6) Tail is short, sensory and without hair. **Tail** and feet are fleshy white.

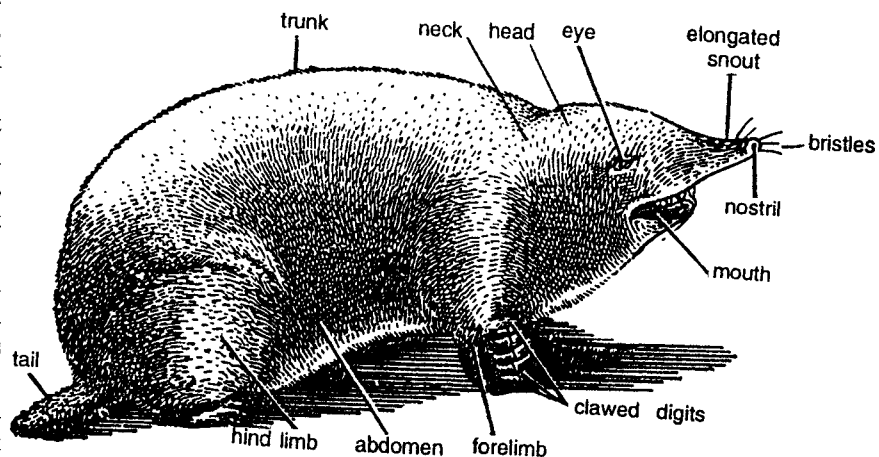

Fig. 2. *Talpa*

- (7) Hind limb large and broad containing 5 digits, each having broad nail, used for digging.
- (8) Forelimb usually with 5 clawed-toes; inner toes not opposable.
- (9) **No marsupial pouch. Single vagina.** Foetus develops within the body of female attached by a placenta to wall of uterus.

**Special features :** It represents a **primitive Eutherian** having **small cranial cavity**, low grade brain (smooth cerebral hemispheres), **inguinal testes**, discoidal and deciduate **placenta** with provision for yolk sac placenta.

**Identification :** Since this mammal has elongated snout, wedge-shaped head and above features, hence it is *Talpa*.

## 9. *Pteropus* : Flying Fox

**Classification :** Same as in *Talpa*. Order Chiroptera, Suborder Megachiroptera.

Genus.....*Pteropus*

**Geographical distribution :** Found in South Eastern Asia, especially in India. Pliocene to Recent.

**Habit and habitat :** Adapted for **arboreal** and aerial mode of life. Lives in groups and feed on fruits (**frugivorous**) and often damage orchards. They sleep by day on tree branches.

**Comments :**

- (1) Commonly called **Fruit bat** or **Flying fox** and in Hindi **Chamgadar**.
- (2) Body is dark-brown coloured and shoulders are golden yellow. Body divisible into **head, neck, trunk and tail** and **patagium**.

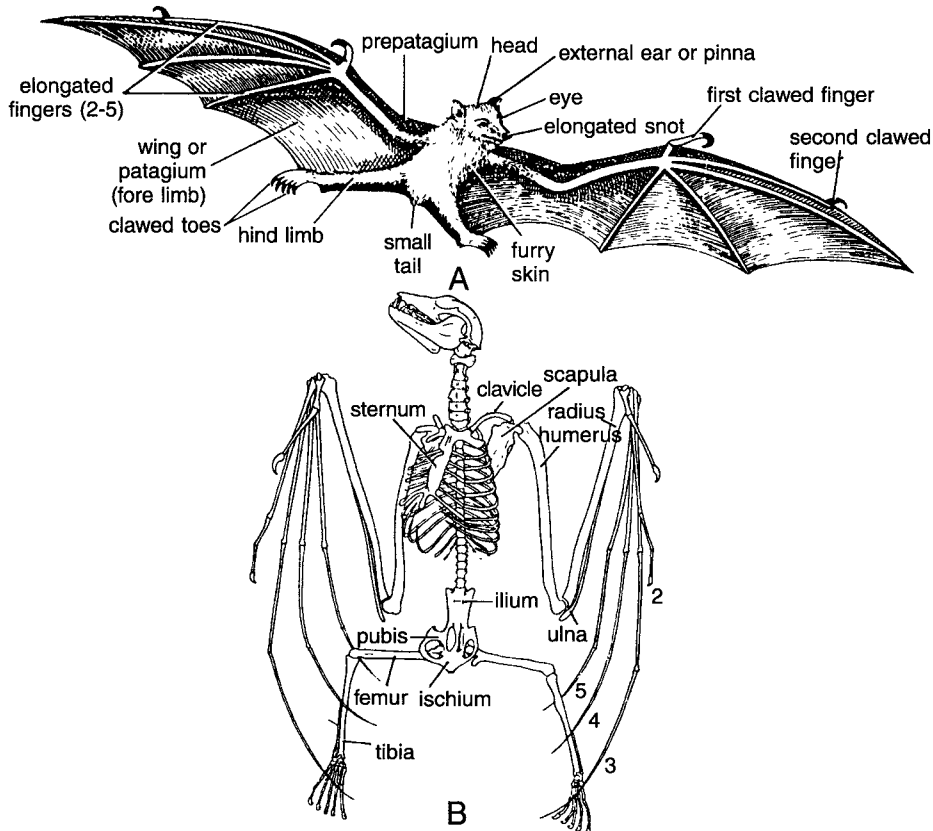

Fig. 3. *Pteropus*. A. Wings expanded, B. Skeleton.

- (3) It is capable of **true flight**. The forelimbs are modified into wings. Humerus, radius, ulna and finger bones are elongated for the support of **patagium**.
- (4) Each **wing** formed by a fold of **skin** or **patagium** supported by elongated forelimb and 2nd to 5th fingers. Only 1st and 2nd fingers bear claws.
- (5) **Hind limbs** and tail also included in **patagium**. Before patagium is **prepatagium**. Hindfeet small with sharp and curved claws. **Tail** small and **stumpy**.
- (6) **Head** small having small external **ears**, large eyes, **snout** and small **teeth**.
- (7) During sleep, **head hangs downwards** with wings folded clock-like around body.

**Special features** : Bats are important due to five reasons : (i) They have **phylogenetic** significance with **insectivores**. (ii) They are the only **flying mammals**, (iii) They are used for **experimental** purposes, (iv) Faeces of bats are used as **fertilizer**, (v) Bats have highly developed **Sonar** or **Echo-apparatus**, a kind of **radar**. While flying they constantly send out ultrasonic sound waves consisting of periodic clicks, which strike on objects or wire and are reflected back to bat. Rate of click increases 50 to 150 seconds as the object is approached. **Ultrasonic sounds** are produced from the **vocal cords**.

**Identification** : Since the animal has patagium and above features, hence it is **Pteropus**.

## 10. *Macaca* : Rhesus Monkey

**Classification** : Same as in *Talpa*.

Order.....Primates	→	Head turns easily on neck.
Sub-order.....Anthropoidea	→	Eyes directed forwards.
Genus..... <i>Macaca</i>		
Species..... <i>mulata</i>		

**Geographical distribution** : Old world monkeys found in India, China, Vietnam and Asia.

**Habit and habitat** : Arboreal (tree living), terrestrial, diurnal and social.

**Comments** :

- (1) Commonly called as **Rhesus monkey** or **Bandar**. Body divided into **head, trunk, tail** and **abdomen**. Head contains, mouth, eye and nostril.
- (2) **Cranium enlarged**, nostrils ringed by bare skin.
- (3) Protrusible **facial muscles** permit emotional expression.
- (4) Body covered with brownish or golden hairs.
- (5) **Nostrils** parallel and directed downwards.
- (6) Internal **cheek** pouched for storing the food.
- (7) **Buttocks** contain two dried **tuberosties** with exposed **calloused skin**.
- (8) Stomach single.
- (9) **External ear** reduced. Forelimbs and hind limbs well developed.
- (10) Thumb is fully opposable which is perfectly adapted for tightly catching branches of trees, twigs and fruits for eating.

**Special features** : Monkeys are famous for caricaturing. Trained monkey's dance provides amusement to children. **Rh blood** factor was first discovered in monkeys which has great significance in blood transfusions. Monkeys exhibit **parental care**. Other monkeys are Squirrel monkey (*Saimiri*), Spider monkey (*Ateles*), Marmoset (*Callithrix*) and Langur (*Presbystis*).

**Identification** : Since the animal contains ischial tuberosties and all above features hence it is **Macaca**.

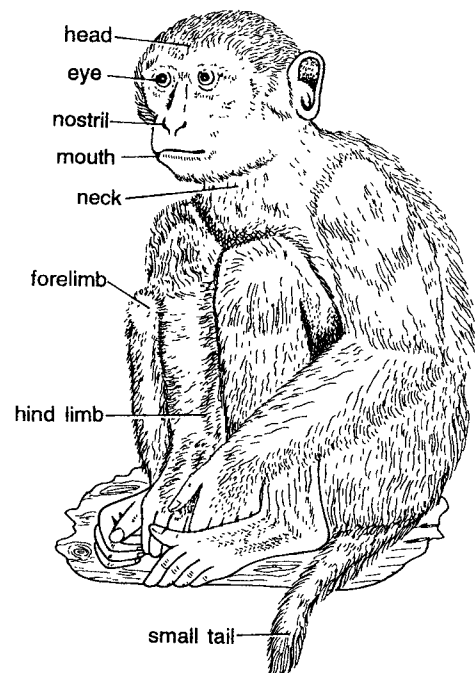

Fig. 4. *Macaca*.

## 11. *Hylobates* : Gibbon

**Classification :** Same as that of Rhesus monkey.

Genus..... *Hylobates*

**Geographical distribution :** South East Asia and Malaya Archipelago.

**Habit and habitat :** Chiefly arboreal, found in rain forests upto 1600 to 2000 metres. feet. Strongly territorial. Rarely descend to ground. Forelimbs are modified for **Brachiating** (swinging).

**Comments :**

- (1) Commonly called as **gibbon**.
- (2) Body slender, **thickly furred** and **tailless**.
- (3) **Height** 3 feet. Body divided into **head, neck, trunk**.
- (4) Head contains **sunken orbit** (eyes) **flat nose** and black face with mouth.
- (5) Prominent **callous pads** on buttocks.
- (6) Gibbons are known for their **remarkable calls**.
- (7) Male and female differ in colours. Female basically fawn. Male brownish.
- (8) **Forelimbs** and **hind limbs** well developed. Forelimbs are long and Gibbons swing around trees with great speed. **Brachiating habit** has induced changes in entire skeleton. Humerus, radius, ulna, carpus

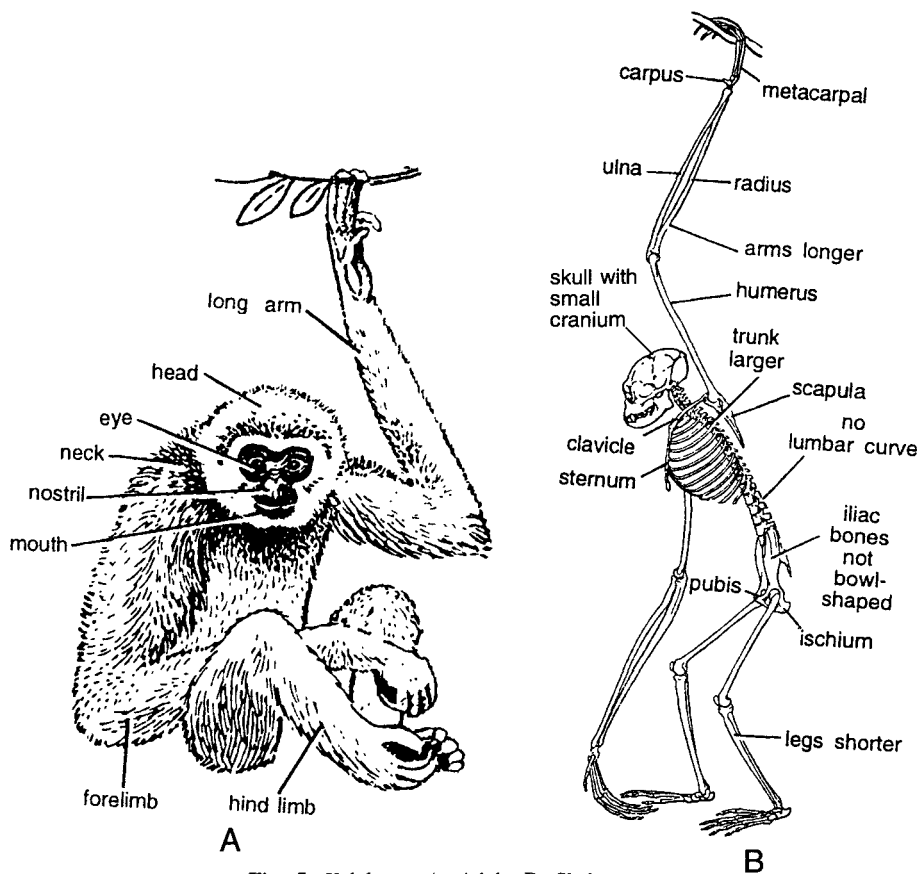

Fig. 5. *Hylobates*. A. Adult, B. Skeleton.

and metacarpals are elongated. Thumb is short but long metacarpals and digits with curved phalanges help in catching branches of trees tightly.

(9) Female produces young one after every 2 years. **Gestation period** 7 months.

(10) On ground they walk on their hindlegs slowly but they seldom descend from trees.

**Special features** : Prominent animal of Zoological gardens. Extremely noisy. They howl, bark and cry.

**Identification** : Since the animal has sunken orbit and all above features hence it is **Gibbon**.

## 12. *Balaenoptera* : Whale

**Classification** : Same as in *Talpa*.

Order.....Cetacea → Fish like aquatic mammal.

Genus..... *Balaenoptera*

**Distribution** : Found in arctic and antarctic waters.

**Habit and habitat** : Largest and heaviest mammal **adapted** for aquatic marine life. It migrates to temperate waters for breeding purposes.

**Comments** :

- (1) Commonly called as blue whale because body is blue above and yellow below.
- (2) Above whale has massive size measuring 35 meters in length and 1.5 lac kg in weight.
- (3) *Balaenoptera* is longest whale and largest mammal flourishing very well.
- (4) Body is divisible into small **head**, **large trunk** and **tail**.
- (5) Body contains **paddle-like forelimbs**, **dorsal fin** and **tail flukes**.
- (6) Whale contains fringed **baleen** consisting of two rows of transverse plates of keratin for filtering planktones.

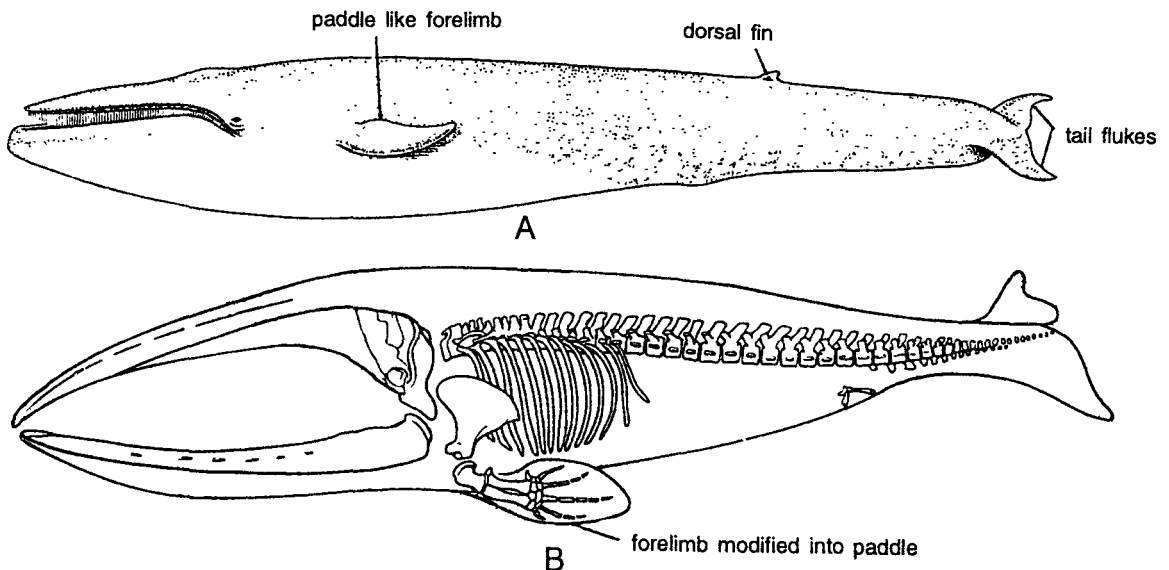

**Fig. 6.** *Balaenoptera*. A. Adult, B. Skeleton.

- (7) Tail flukes are like two forked lobe of tail fin of fish. They provide strong propulsive thrust allowing upward movement of flukes which cause forward movement of whale. Tail flukes are operated by strong muscles inserted into hind most vertebrae of tail fluke.
- (8) Stability and balance is provided by the **paddle like forelimbs** acting as **hydroplanes**.
- (9) Tail flukes and dorsal fins are **neomorphus** i.e., they are only folds of skin without any skeletal support but guided by strong muscles.
- (10) Paddle-like forelimbs are adapted for swimming.

**Identification** : Since the animal contains tail fluke and above features, hence it is **whale**.

### 13. *Equus caballus* : Horse

**Classification** : Same as that of *Talpa*.

Order..... *Perissodactyla* → Odd-toed hoofed mammals.

Genus..... *Equus*

Species..... *caballus*

**Geographical distribution** : Eocene to Recent. Found in Eurasia, Africa, and tropical America. Cosmopolitan.

**Habit and habitat** : Horses live in herds in open plains and grasslands. Wild Przewalski's horses live in deserts between Mongolia and China. Horses are domesticated. One of the fastest running animals.

**Comments** :

- (1) Commonly called as **modern horse**.
- (2) Horses support their entire body weight on the third toe of each foot. Other toes have atrophied to rudimentary **splints**. This is excellent adaptation for swift running on the open plains.
- (3) Body of horse is massively built and divided into **head, neck, trunk, chest, abdomen** and **tail**.
- (4) **Head** is small and characteristic. Teeth adapted for grazing and specialized for grinding coarse siliceous grasses. Jaws are elongated typically 'horse' like. Ears shorter.
- (5) **Neck** is long and mobile. Mane longer and pendant.
- (6) **Trunk** is large.
- (7) Each foot ends in a large hoof. Metatarsals and tarsals fused. Hind legs and fore legs well developed and adapted for fast running.
- (8) Tail is bushy completely covered with long hairs.

**Special features** : Horse shows following features—(i) Horse is a very familiar animal to man. (ii) It provides excellent evidence for organic evolution. It has been very useful animal to mankind, used in wars and transport. (iii) Horse racing is most commercial and amusing game. *Equus przewalskii* of Mongolia is the only surviving wild horse from which nearly 50 to 60 domesticated horses have been derived. (iv) Horse symbolizes truth and secrecy. Very familiar saying that from '**Horses mouth**'. (v) Horse also symbolizes **strength** or **power** of heavy machines such as **2 horse power**, **5 horse power** etc. Horses also form part of Army for wars.

**Identification** : Since the animal has peculiar jaws and above feature, hence it is *Equus caballus*.

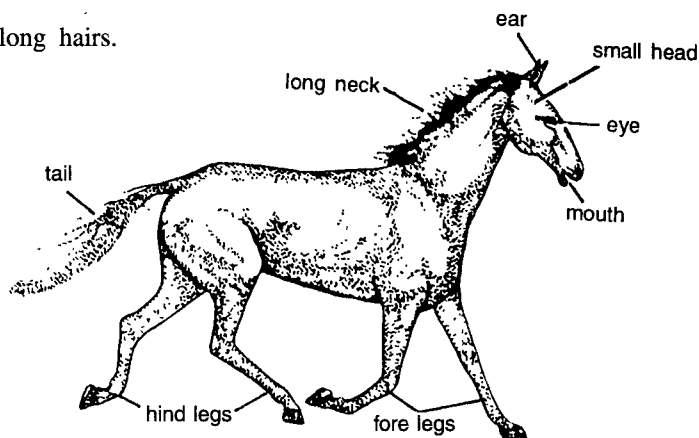

Fig. 7. *Equus caballus* (Horse).

## 14. *Ichthyophis*

### Classification :

Phylum.....	Chordata	→	Dorsal tubular nerve cord, notochord and gill-slits present.
Group.....	Craniata	→	Definite head. Cranium with brain present.
Sub-phylum.....	Vertebrata	→	Vertebral column present.
Division.....	Gnathostomata	→	Jaws and paired appendages present.
Superclass.....	Tetrapoda	→	Paired limbs, lungs, cornified skin and bony skeleton.
Class.....	Amphibia	→	Cold blooded. Scaleless glandular skin. Can live both in water and on land.
Order.....	Gymnophiona or Apoda	→	Two occipital condyles. Heart three-chambered.
Genus.....	<i>Ichthyophis</i>	→	Vermiform Amphibia without limbs or limb girdles.

**Geographical distribution :** *Ichthyophis* is distributed in tropical regions and found in Sri Lanka, Philippines, Borneo, Java, Scychelles, Mexico to Argentina and India (Mysore) and is the only representative of Gymnophiona living today in tropical countries.

**Habit and habitat :** *Ichthyophis* lives in **burrows** and leads a fossorial life in moist ground. The animal is blind and adapted for burrowing life. It feeds on invertebrates.

### Comments :

- (1) Commonly called as **caecilian**.
- (2) Animal is worm-like and slender, measuring about 30 cm in length. Body divided into **head, trunk and tail**.
- (3) Body is covered with a smooth, slimy and transversely ringed skin consisting of small calcified scales arranged in transverse rows. **Squirt glands** in skin discharge an irritating fluid.
- (4) **Head** contains **eyes, nostrils** and a pair of **sensory tentacles**. Tympanic membrane, tympanic cavity and columella absent.
- (5) **Eyes** small, functionless and covered by skin. Though reduced but contain all the parts. A small protrusible tentacle is present between eye and nostril.
- (6) Skull compact, roofed with bone.
- (7) Limbs and limb girdles absent. Vertebrae **amphicoelous**.
- (8) Laryngotracheal chamber is prolonged into a distinct trachea. Right lung elongated, while left lung is reduced. Anus is sub-terminal.
- (9) Males are provided with **eversible copulatory organ**, which shows advanced characters. **Fertilization internal**. Male's cloaca is everted like copulatory organ. Eggs are laid in moist burrows. Mother coils around eggs till they hatch into tadpoles.

**Special features :** *Ichthyophis* resembles Amphibia in having a 3-chambered heart, conus arteriosus and brain like Amphibia. But it differs from living Amphibia in having scales in dermis and meroblastic eggs. The animal also shows parental care, as the

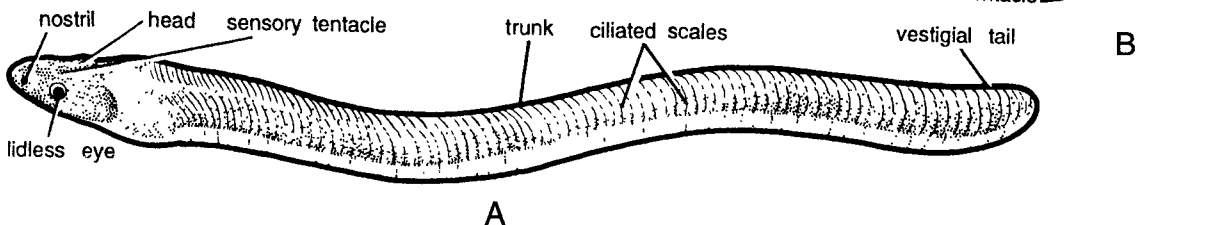

Fig. 8. *Ichthyophis* : A. Male, B. Coiled female containing eggs.

females take care of the eggs by keeping them in the coils of the body, till they hatch. It shows combination of primitive and advanced characters. The former characters include dermal scales in the skin and number of dermal bones in the skull. Loss of limbs, short post-anal part and copulatory organs are specialized characters.

**Identification :** Since the animal is **limbless**, contains calcified scales and vestigial tail and above features, hence it is *Ichthyophis*.

## 15. *Uraeotyphlus*

**Classification :** Same as that of *Ichthyophis*.

Genus.....*Uraeotyphlus*

**Geographical distribution :** *Uraeotyphlus* has been reported from India, Malayasia, South Africa and South America.

**Habit and habitat :** *Uraeotyphlus* also **burrows** in moist ground. It feeds on small worms.

**Comments :**

- (1) *Uraeotyphlus* is **worm-like** and elongated.
- (2) Limbs are reduced due to burrowing habit.
- (3) Body elongated, vermiform and covered with naked skin in which small **dermal scales** are embedded. Body divided into **head, trunk** and **tail**.
- (4) Colour of body is brown or black above and white below.
- (5) Small scaleless **head** contains **eyes** and **nares**.
- (6) Eyes are **non-functional**, indistinct and concealed beneath the slimy skin.
- (7) It has a peculiar sensory tentacular apparatus consisting of protrusible flap-shaped or globular soft tentacle lodged in a groove of maxilla between eye and nostril.
- (8) Respiration through lungs. Right lung is exceptionally large and sac-like.
- (9) **Tail** is extremely short. Anus sub-terminal.

**Special features :** This Apoda also reveals combination of **primitive** and **advanced** characters. The presence of dermal scales in the skin and number of dermal bones in the skull are primitive characters. While specialized characters are loss of limbs, very short post-anal part and copulatory organs.

**Identification :** Since the animal is limbless, slender and has above features, hence it is *Uraeotyphlus*.

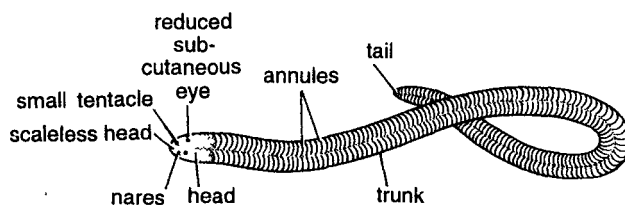

Fig. 9. *Uraeotyphlus*.



## 16. *Typhlops* : Blind Snake

### Classification :

Phylum.....	Chordata	→ Dorsal tubular nerve cord, notochord and gill-slits present.
Group.....	Craniata	→ Definite head. Cranium with brain present.
Sub-phylum.....	Vertebrata	→ Vertebral column present.
Division.....	Gnathostomata	→ Jaws and paired appendages present.
Super-class.....	Tetrapoda	→ Paired limbs, lungs, cornified skin and bony skeleton.
Class.....	Reptilia	→ Scaly vertebrates with right and left aortic arches. Single condyle. Pulmonary respiration. Embryo with amnion and allantois.
Sub-class.....	Diapsida	→ Skull with two temporal openings separated by postorbital and squamosal.
Order.....	Squamata	→ Lizards and snakes with horny epidermal scales or shields. Quadrate bone movable. Vertebrae procoelous. Anal opening transverse.
Sub-order.....	Ophidia	→ Snakes. Limbs, feet, ear openings sternum and urinary bladder absent. Mandibles jointed anteriorly by ligament. Tongue slender, bifid and protrusible. Left lung reduced.
Family.....	Typhlopidae	→ Eyes vestigial under opaque scales.
Genus.....	<i>Typhlops</i> (Blind snake)	

**Geographical distribution :** *Typhlops* is widely distributed in Europe, Asia, Africa, America, Australia, India, tropics and sub-tropics of both hemispheres.

**Habit and habitat :** It is a **burrowing** snake feeding on small insects, earthworms and soft larval insects.

### Comments :

- (1) Commonly known as **blind snake**. Body divided into **head, neck, trunk and tail**.
- (2) Body is elongated, cylindrical, measuring about 175 to 180 mm and covered by thin **overlapping cycloid scales** in multiple rows over whole body.
- (3) Animal looks like earthworm and is of dark chocolate colour.
- (4) There is no **distinct head** and also there is no differentiation between dorsal and ventral scales which are in **multiple rows** over whole body. Head contains mouth nostril and eye.
- (5) Lower jaw without **teeth**, maxilla toothed and transversely placed, ectopterygoid and squamosal absent and pterygoid separate from quadrate.
- (6) **Rostral, nasal, ocular and pre-ocular shields** are larger.
- (7) Eyes are indistinct and covered with scales. They are immobile and **without eyelids**.
- (8) **Limbs, feet, ear openings, sternum, urinary bladder absent**. Mandibles join anteriorly by ligament. Tongue slender, bifid, protrusible. Left lung reduced.

**Identification :** Since this snake contains indistinct head and eyes and above features, hence it *Typhlops*.

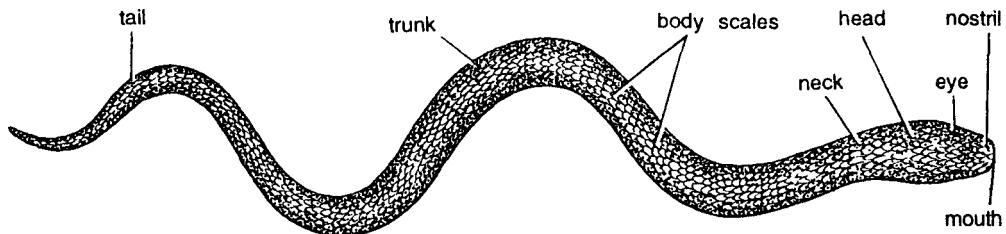

Fig. 10. *Typhlops*.

## C. ADAPTIVE MODIFICATION OF FEET OR CLAWS IN BIRDS

### 17. Types of Feet or Claws in Birds

The feet of birds are also modified variously in accordance with the character of the environment and the manner of locomotion. For illustration see figure 11.

1. **Cursorial or running feet.** In **running birds**, the legs are powerful and the number of toes is reduced. Hind toe may be elevated, reduced or absent. In **bustards, coursers** and **ratites** such as **emu, rhea** and **cassowary**, only 3 toes directed forwards are present. **Ostrich** [Fig. 11 (1)] has only 2 toes, of which the outer one is smaller and without a nail.
2. **Perching feet.** Majority of birds belong to the category of **perching birds** or such as **finche** [Fig. 11 (3)], **sparrows**, [Fig. 11 (2)] **crows, bulbuls, robins, mynahs**, etc. Toes are anterior and slender, while one toe or hallux is posterior, strongly built and apposable, so that they can securely fasten the foot to a branch or a perch.
3. **Scratching feet.** Feet of **fowls**, [Fig. 11 (7)] **quails** and **pheasants**, etc. are stout, with strongly-developed claws and well **adapted for running** as well as **scratching** the earth. Foot of male bird is usually provided with a pointed bony spur of offence and defence.
4. **Raptorial feet.** Predatory or carnivorous birds, such as **eagles, kites, vultures** and **owls**, [Fig. 11 (4)] etc. have strongly taloned feet for **striking** and **grasping** their prey. Toes have strongly developed, sharp and curved claws. Large and fleshy bulbs, called **tylari**, are found on the undersurface of the toes, especially developed in the **sparrow-hawk**. In **osprey** [Fig. 11 (5)] and **Ketupa**, tylari are absent but horny spines are present, which help in gripping slippery preys such as fish.
5. **Wading feet.** Legs and toes are exceptionally long and slender in **wading** or **marshy** birds such as **herons**, [Fig. 11 (11)] **snipes, jacana**, [Fig. 11 (6)] **lapwing**, etc. These serve to **walk over** aquatic vegetation or marshes. Web is absent or feebly developed.
6. **Swimming feet.** In **swimming birds**, the **toes** are **webbed**, partially or completely. In diving birds, like **coots** [Fig. 11 (9)] and **grebes**, [Fig. 11 (10)] the web is lobate and the toes are free. In swimming and paddling birds, such as **ducks** [Fig. 11 (12)] and **teals, avocet** [Fig. 11 (8)] only the anterior 3 toes are united in a web. In **pelican** and **cormorant** [Fig. 11 (13)] all the 4 toes are enclosed in the web.
7. **Climbing feet.** In **parrots** [Fig. 11 (17)] and **woodpeckers** [Fig. 11 (14)] the feet are used as **grasping organs** and especially adapted for **climbing vertical** surfaces. Second and third toes point in front, while the first and the fourth toes point backwards.
8. **Clinging feet.** In **swifts, martinets** [Fig. 11 (15)] **king fisher** [Fig. 11 (16)] and **humming birds**, all the 4 toes point forwards and serve to cling to steep faces of cliffs or under caves of houses, etc.

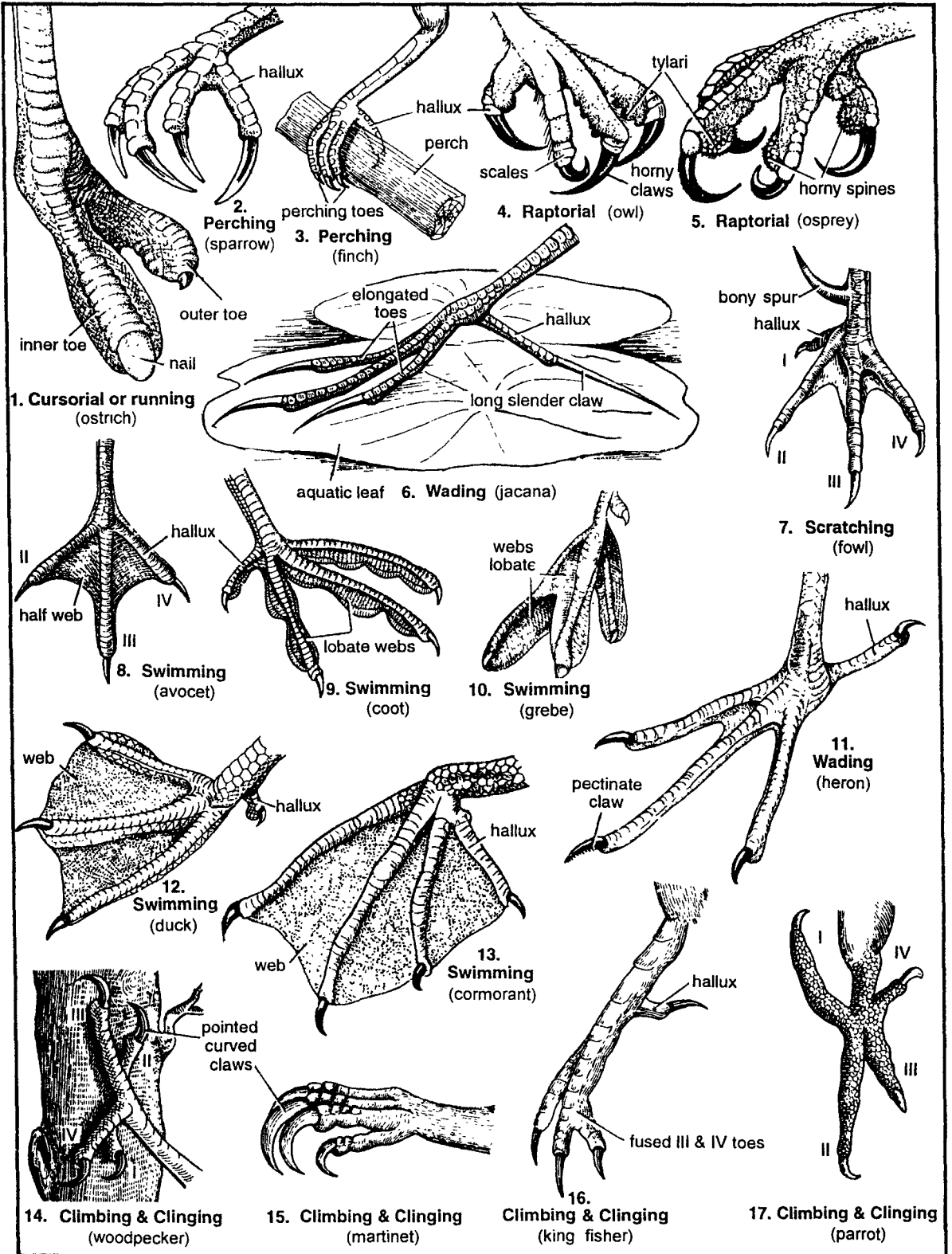

(Z-21)

Fig. 11. Types of Feet or Claws in Birds.

## D. ADAPTIVE MODIFICATION IN MOUTH PARTS OF INSECTS

### 18. *Culex* : Male : Head and Mouth Parts

#### Comments :

- (1) **Head** and the **mouth** parts are seen clearly under low magnification of the microscope.
- (2) **Body** is differentiated into **head, thorax** and **abdomen** (Fig. 12).
- (3) In male *Culex*, **maxillary palps** are longer than **labium** and **antennae** possess long and bushy delicate hairs in bunches as joints.
- (4) **Head** is freely movable on a narrow neck, having large **black compound eyes** and **antennae** and **clypeus articulates** with **labrum-epipharynx**.
- (5) Mouth parts contain **labrum-epipharynx**, **needle shaped mandibles** and **maxillae**, **hypopharynx**, **maxillary palps** and **labium** with tactile hairs.
- (6) **Mouth parts** are of **sucking** type.
- (7) It communicates **filariasis** (causing **elephantiasis**).

**Identification :** Since the mouth has long maxillary palps, hence it is **head and mouth parts of male *Culex***.

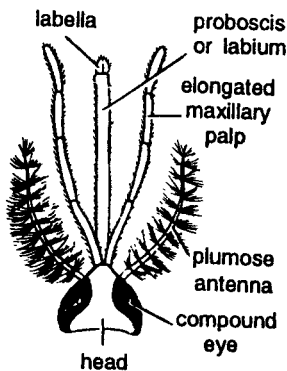

Fig. 12. *Culex*. Head and mouth parts of male.

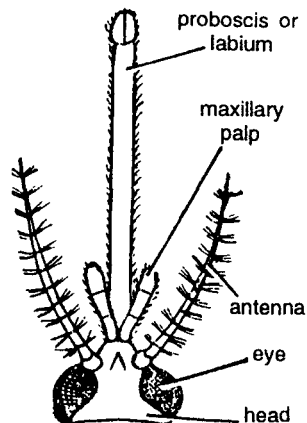

Fig. 13. *Culex*. Head and mouth parts of female.

### 19. *Culex* : Female : Head and Mouth Parts

#### Comments :

- (1) In female *Culex*, **maxillary palps** are exceedingly short and **antennae** contain a few short hairs at joints (Fig. 13).
- (2) **Head** is freely movable on a slender neck, having large black compound eyes and antennae.
- (3) **Clypeus articulates** with **labrum-epipharynx**.
- (4) **Mouth parts** are of **piercing and sucking** type, composed of **labrum-epipharynx**, **needle-like mandibles** and **maxillae** and **hypopharynx**. **Maxillary palps** are three-jointed.
- (5) **Maxillary palps** and **labium** containing **tactile hairs** forming **proboscis sheath**.
- (6) It helps in transmission of **elephantiasis** disease.

**Identification :** Since the mouth has short maxillary palps, hence it is **head and mouth parts of female *Culex***.

## 20. *Anopheles* : Male : Head and Mouth Parts

### Comments :

- (1) **Head** and its **mouth parts** are distinct, which can be observed under dissecting microscope and in low magnification of the microscope (Fig. 14).
- (2) **Head** is freely movable on a slender neck, having large black compound eyes and antennae.
- (3) **Clypeus** articulates with **labrum** and **epipharynx**.
- (4) Mouth parts are **piercing and sucking type** composed of **labrum-epipharynx**, **needle-shaped, mandibles**, and **maxillae hypopharynx**, **maxillary palps** and **labium**. **Maxillary palps** are **club-shaped** and are nearly equal to labium or **proboscis**; and **antennae** have long, bushy hairs at their joints.
- (5) It does not help in transmission of **malarial disease** and feeds on plant juices.

**Identification :** Since the mouth has club-shaped maxillary palps, hence it is **head and mouth parts of male *Anopheles***.

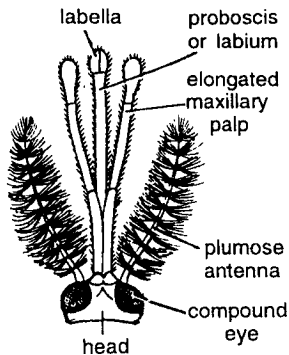

Fig. 14. *Anopheles*. Head and mouth parts of male.

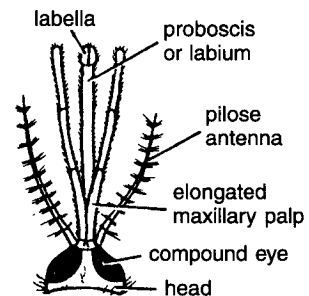

Fig. 15. *Anopheles*. Head and mouth parts of female.

## 21. *Anopheles* : Female : Head and Mouth Parts

### Comments :

- (1) **Head** and its **mouth parts** are clearly seen under dissecting microscope under low magnification of compound microscope (Fig. 15).
- (2) **Antennae** possess a few short hairs at joints.
- (3) **Head** is freely movable on a delicate and slender neck, having large black **compound eyes** and **antennae**.
- (4) **Clypeus** articulates with **labrum** and **epipharynx**.
- (5) **Mouth parts** are **piercing and sucking type**, composed of **labrum-epipharynx**, **needle-shaped mandibles** and maxillae, **hypopharynx**, **maxillary palps** and **labium**. **Maxillary palps** are simple and equal to labium or proboscis.
- (6) It transmits **malarial disease** and acts as **intermediate** host for *Plasmodium*.

**Identification :** Since the mouth contains simple maxillary palps, hence it is **head and mouth parts of female *Anopheles***.

## 22. *Musca domestica* : Housefly : Head and Mouth Parts

### Comments :

- (1) *Musca domestica* or **housefly** belongs to order **Diptera** and contains **sponging** mouth parts, adapted for **sucking** liquid food (Fig. 16).
- (2) These insects lack the cutting apparatus.
- (3) Head bears **Ocelli** on ocular plate and large compound eyes and mouth parts. Antennae are aristat.
- (4) **Mouth parts** are composed of **proboscis, short maxillary palps, labrum-epipharynx** and **hypopharynx**. **Mandibles** are absent.
- (5) **Maxillae** are represented by short and unjointed **maxillary palps** before the rostrum.
- (6) **Labrum** is fused with the epipharynx and forms a narrow slender tube opening ventrally.
- (7) **Hypopharynx** is narrow structure. Containing salivary duct and fits into the tube constituted by labrum-epipharynx.
- (8) **Proboscis** is **retractile, fleshy** and differentiated into **basal rostrum, middle haustellum** and **upper labellum**. **Labellum** contains **pseudo-tracheal, canals**, bounded by **pseudo-tracheal membrane**. Labium forms a tube and encloses **labrum-epipharynx** and **hypopharynx**.
- (9) **Hypopharynx** and labrum constitute the food channel. Other structures seen are **gene, epistome, apodeme, discal sclerite** and **hyoid sclerite**.

**Identification :** Since the mouth contains pseudo-tracheae in labellum, and all above features, hence it is **W.M. head and mouth parts of *Musca domestica*.**

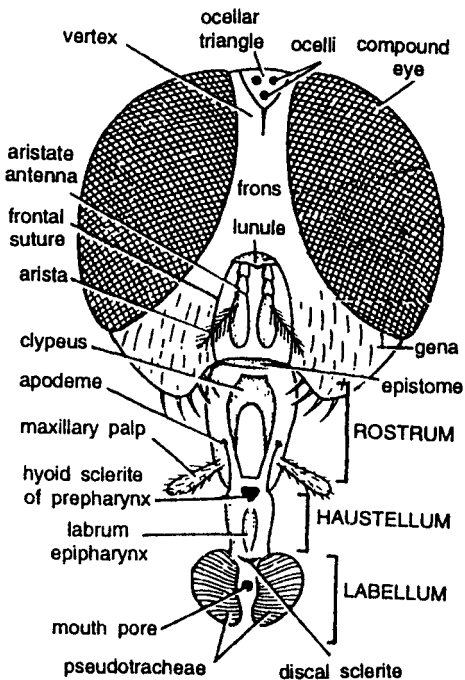

Fig. 16. Head and mouth parts of housefly.

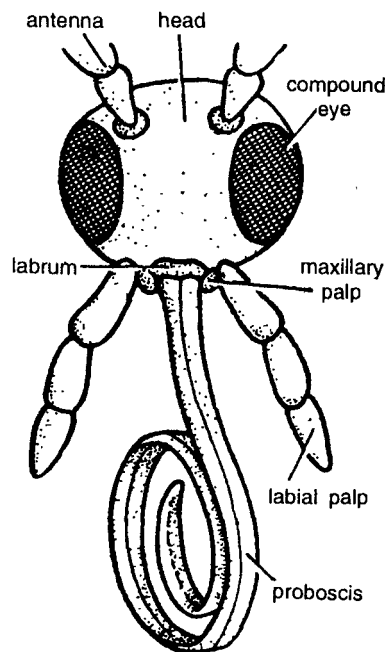

Fig. 17. Head and mouth parts of butterfly.

### 23. Butterfly : Head and Mouth Parts

#### Comments :

- (1) Butterfly, belonging to order **Lepidoptera**, contains siphoning or **sucking mouth parts**. Head may be examined under binocular microscope for mouth parts (Fig. 17).
- (2) **Head** of butterfly is composed of large **compound eyes** and **antennae**. It is broad and **contains siphoning type of mouth parts**.
- (3) **Mouth parts** are composed of small labrum in front of **clypeus**, **triangular labium** and **coiled proboscis**.
- (4) **Mandibles** are absent.
- (5) Proboscis is composed of elastic cuticle and greatly elongated **galeae of maxillae**, **grooved internally forming food canal for nectar**.
- (6) **Proboscis** lies in **coiled stage**, but it immediately uncoils and protrudes in response to a food stimulus, due to rise in blood pressure.
- (7) **Labium** is triangular and plate-like containing labial palps.
- (8) Other joints of maxillae and maxillary palps are reduced or vestigial.
- (9) Head contains ventral groove for proboscis.

**Identification :** Since the mouth contains coiled proboscis, hence it is the mouth parts of **butterfly**.

### 24. *Apis* : Honey-bee : Mouth Parts of Worker

#### Comments :

- (1) **Honey-bee** belonging to the order **Hymenoptera**, contains **rasping and lapping** mouth parts, adapted for collection of **nectar and pollen** (Fig. 18).
- (2) **Head** is triangular, containing large **compound eyes**, **3 ocelli antennae** and **mouth parts**.
- (3) Mouth parts are composed of **spoon-shaped mandibles**, **labrum** and **maxillae** devoid of lacinia.
- (4) **Mandibles** are smooth and **spatulate type**, found on either side of the labrum.
- (5) It contains **vestigial maxillary palps** and **blade-like galea**.
- (6) Labellum is **spoon-shaped, grooved internally** forming a tube and is called as tongue.
- (7) **Epipharynx** is soft and triangular lying below the **labrum**. **Cardo** and **stipes** are well developed.
- (8) Liquid food taken along tongue is converted into honey in honey-sac by enzymes from salivary glands.
- (9) **Prementum** contains segmented **labial palps**, **paraglossae** and **glossae**.
- (10) Honey-bee also **moulds waxes** in its hive.

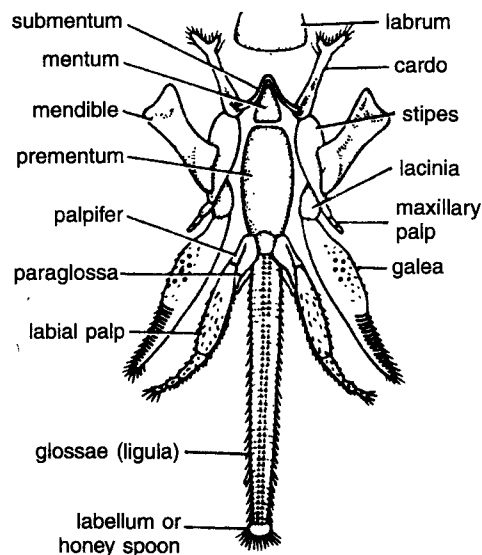

**Fig. 18.** Honey-bee. Mouth parts of worker.

**Identification :** Since the mouth contains spoon-shaped labellum, hence these are **mouth parts of worker**, honey-bee.

## E. SERIAL HOMOLOGY

### 25. *Palaemon* : Prawn : Appendages

**Instructions :** Study and draw the following appendage (19 pairs) as shown serially in figure. 19.

#### A. Cephalic Appendages

- (1) **Antennule** : It is sensory and tactile in function and contains inner and outer feelers, **basis**, **coxa**, **precoxa** and **stylocerite**. Precoxa contains statocyst and is large. The basis is longer than coxa and carries 2 long sensory feelers. Outer feeler is divided into 2 unequal branches (Fig. 20).
- (2) **Antenna** : It is sensory, excretory and balancing, and it consists of **coxa** and **basis** which bears an expanded leaf-like exopodite, called as **squama**, and a long narrow feeler.
- (3) **Mandible** : Mandibles are short and stout, lying one on each side of the mouth. It is masticatory in function and consists of coxa. The coxa is densely calcified to form powerful jaws. Its proximal part is spoon-shaped, having cavity for muscle insertion and is called as apophysis, while the distal part is called as head. Head contains stout molar process and a flat plate-like incisor process. Its outer border also contains a 3-jointed **mandibular palp**.
- (4) **Maxillula** : It also helps in **manipulation of food** and consists of **coxa**, **basis**, **gnathobases** and **endopodite**.
- (5) **Maxilla** : This manipulates food and is composed of **coxa**, **basis**, **gnathobases** and **endopodite**.

#### B. Thoracic Appendages

It comprises of anterior 3 pairs of **maxillipedes** and **posterior 5 pairs of walking legs** (Fig. 21).

- (1) **First maxillipede** : (i) It is formed by flattened, leaf-like **coxa** and **basis**. (ii) Coxa contains a bilobed leaf-like **epipodite**. (iii) **Endopodite** is small and unsegmented. (iv) The **exopodite** is also unsegmented but is elongated, with a basal plate-like expansion.
- (2) **Second maxillipede** : (i) It comprises of **coxa** and **basis**. It is not so flattened. (ii) Coxa is short and contains a small **epipodite** and **gill** on outer side and setae on inner side. (iii) Basis is jointed to ischium of endopodite. (iv) Endopodite comprises of 5 segments namely **ischium**, **merus**, **carpus**, **propodus** and **dactylus**. (v) **Exopodite** is elongated and contains **setae**.
- (3) **Third maxillipede** : (i) It is leg-like and comprises of **coxa** and **basis**. (ii) Coxa has a small epipodite

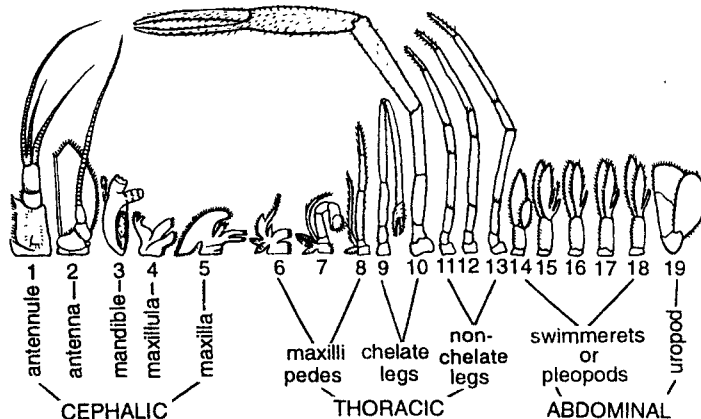

**Fig. 19.** *Palaemon* : Prawn. Serial arrangement of appendages (19 pairs).



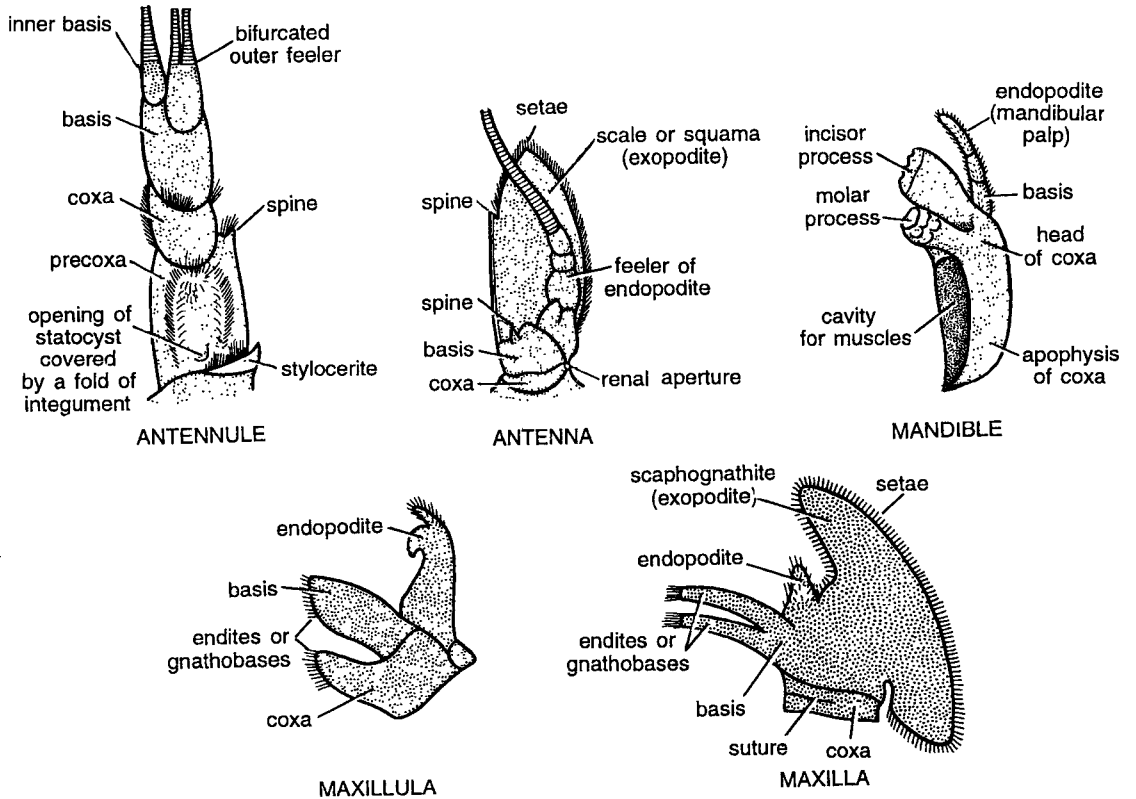

Fig. 20. *Palaemon* : Prawn. Cephalic appendages.

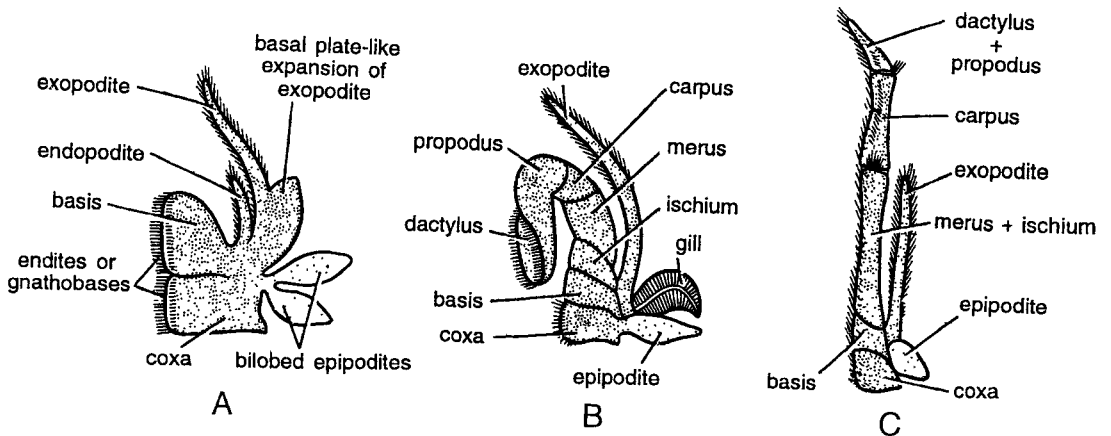

Fig. 21. *Palaemon* : Prawn. Maxillipedes.

on its outer side and basis bears a slender unjointed **exopodite** and an elongated **endopodite**. (iii) The endopodite is composed of 3 podomeres, proximal podomere fused with merus, middle carpus and terminal one fused with dactylus. (iv) Setae are found all along exopodite and on inner margin of **endopodite**.

- (4) **Typical leg** : (i) There are 5 pairs of walking legs differing from maxillipedes in the absence of exopodite and endopodite and also greater in size. (ii) A typical leg or 4th leg consists of 2-jointed

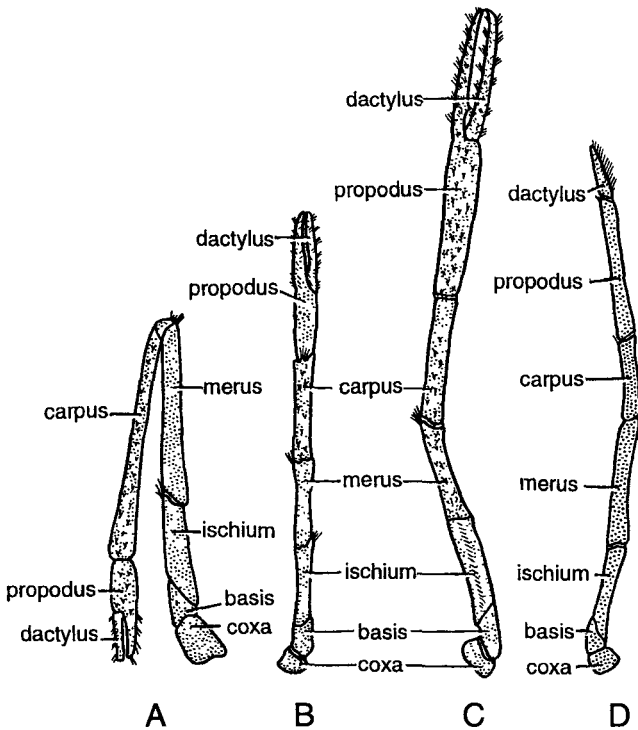

Fig. 22. *Palaemon* : Prawn. Walking legs. A. Typical (4th) non-chelate legs, B. 1st chelate leg, C. 2nd chelate leg of female, D. 2nd chelate leg of male.

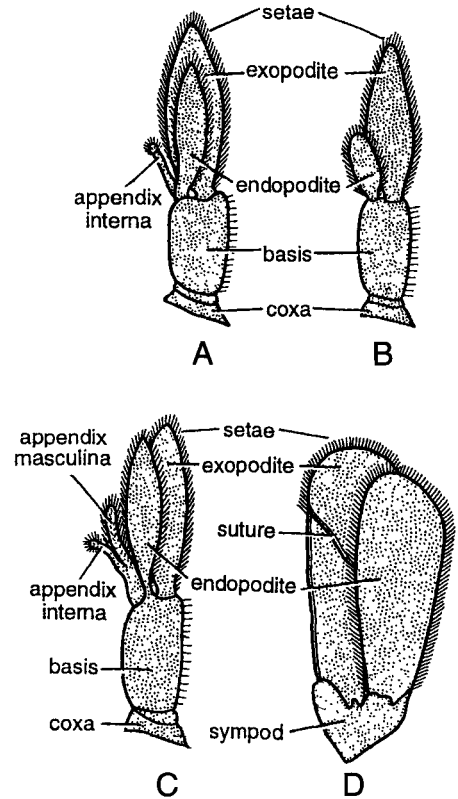

Fig. 23. *Palaemon* : Prawn. Abdominal appendages (pleopods). A. Typical, B. First, C. 2nd of male, D. Uropod.

**protopodite** and a 5-jointed **endopodite**. (iii) All the seven podomeres namely **coxa**, **ischium**, **merus**, **carpus**, **propodus** and **dactylus**, are arranged in linear series and hinged together (Fig. 22).

- (5) **First chelate leg** : (i) In this, the propodus is prolonged beyond its articulation with the dactylus, so that 2 podomeres work one against the other like forceps blades forming chela or pincer and such legs are called as cheliped or chelate legs. (ii) Setae cover entire surface.
- (6) **Second chelate leg** : (i) All podomeres are considerable elongated. (ii) In males, it is more powerful than in female. Third, fourth, and fifth pairs of legs are **non-chelate** and typical. In males, each fifth leg bears a male genital aperture on the arthroal membrane between leg and thorax. In female, the genital aperture is found on the inner side of the coxa of third leg.

### C. Abdominal Appendages

There are six pairs of **abdominal appendage**. These are typical **biramous appendages**, one pair in each abdominal segment. They help in **swimming** and hence called as swimmerets or **pleopods** (Fig. 23).

- (1) **Typical abdominal appendages** (3rd appendages) : (i) The **protopodite** has ring-like coxa and a **cylindrical basis**, (ii) The basis bears flattened leaf-like smaller **endopodite** and a larger **exopodite**. (iii) From inner basal margin of endopodite, a small knob-headed rod-like structure arises, called as **appendix interna**. (iv) In female, the appendix interna of opposite appendages articulate with each other forming bridges to carry the eggs. (v) The outer surface of basis and margins of exopodite and endopodite contain several setae. (vi) Remaining appendages slightly differ from typical ones.
- (2) **First abdominal appendage** : Appendix interna absent and endopodite greatly reduced.

- (3) **Second abdominal appendage** : In males only, in addition to appendix interna, there is additional rod-like and setae-bearing process called as **appendix masculina**, found between appendix interna and endopodite.
- (4) **Uropods** : Sixth pairs of appendages are called **uropods** lying one on either side of telson. In each uropod, coxa and basis are fused together to form a triangular sympod. **Endo** and **exopodites** are oar-like and their margins bear setae. Exopodite is bigger than endopodite and incompletely divided in the middle by a transverse suture.

**Instructions** : Draw the diagrams of the appendages with help of the practical book.

## EXPERIMENTS ON ANIMAL BEHAVIOUR

Practicals on animal behaviour have been designed for the first time in this book for the under graduate students. The experiments are based on various aspects of animal behaviour such as learning, conflict, predation, signalling, courtship and phototaxis and toxic effects on behaviour etc.

The practical exercises are of two types (A) Photographs and designs/figures depicting various aspects of animal behaviour and (B) Phototaxis and Toxicological responses.

### A. STUDY OF PHOTOGRAPHS

Study of photographs deals with **Conflict behaviour, Predation pressure, Fixed Action Pattern (FAP), Courtship and Territorial Behaviour of the birds.**

#### 26. Conflict Behaviour

**Comments :**

- (1) Conflict behaviour is considered to have been originated from some stereotyped display behaviour.
- (2) Conflict behaviour arises as an incidental effect of the neural system, controlling attack and escape behaviour.
- (3) In Herring gulls, the conflict behaviour accurately signals to attack and stopping one male from entering into the territory of other males.
- (4) In above, 3 birds have been shown in which 2 male birds are opposite each other dose to the territory, the female bird is behind the male bird.
- (5) Both above male birds are motivated by aggression and fear.
- (6) One male bird responds by pulling grass within safe zone of territory.

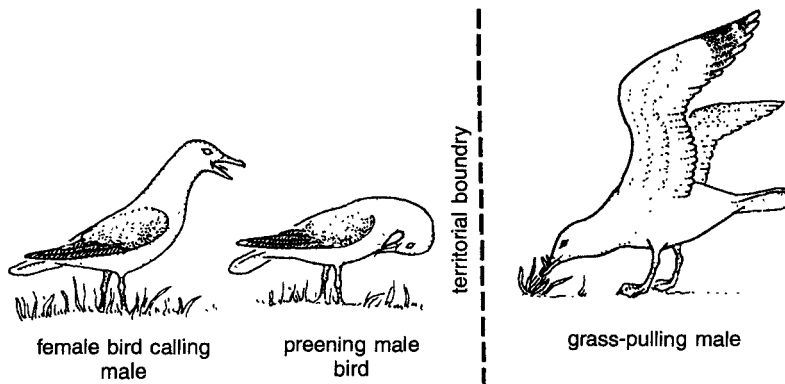

Fig. 24. Conflict behaviour of herring gulls.

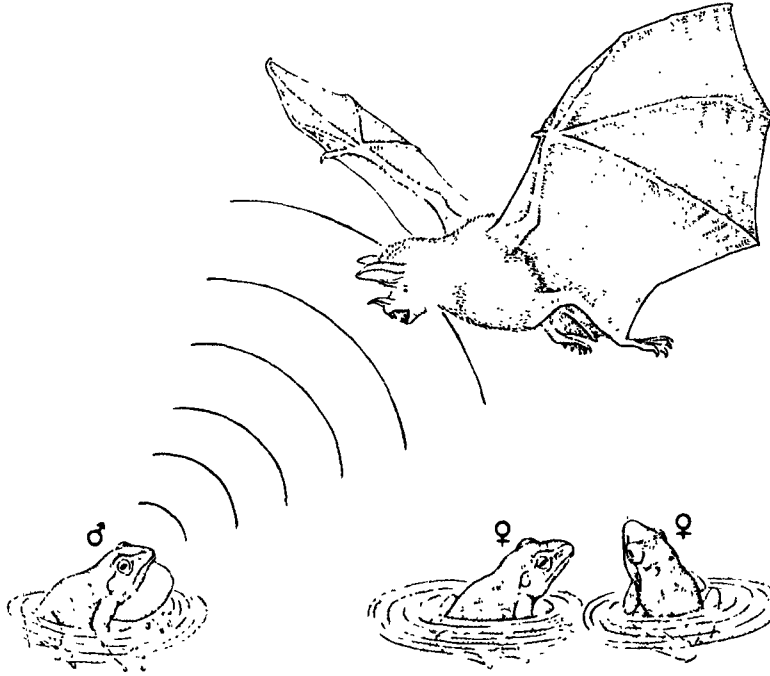

Fig. 25. Predation behaviour.

- (7) The other male bird responds by preening its feathers with a bent head rather than attacking the other. The female bird calls behind the preening bird.

## 27. Predation Pressure

### Comments :

- (1) Above photograph depicts predation pressure involving male Tungara frog and illegitimate call receiver bat (Fig. 25).
- (2) Male frog calls loudly at night to attract female frog for mating.
- (3) Call of male frog also attracts nocturnal bat which is illegitimate call receiver. The bat sweeps through water to catch, kill and eat the frog (prey).
- (4) Frog avoid predation risk by stopping the calls when it detects a flying bat.
- (5) Frog produce very narrow frequency calls by which they may not mate but survive and may mate at next opportunity and thus fulfil their reproductive requirement.

## 28. Fixed Action Pattern (FAP) Behaviour : Courtship Behaviour

### Comments :

- (1) Fixed Action Pattern (FAP) behaviour or courtship behaviour is mediated by genes and exhibited automatically by animals without seeing or learning (Fig. 26).
- (2) Above behaviour is observed even if the animal is developed in isolation.
- (3) **Courtship** is a good example of Fixed Action Pattern behaviour.
- (4) During courtship behaviour the male peacock spreads its wings and dances during rain to attract its mate.

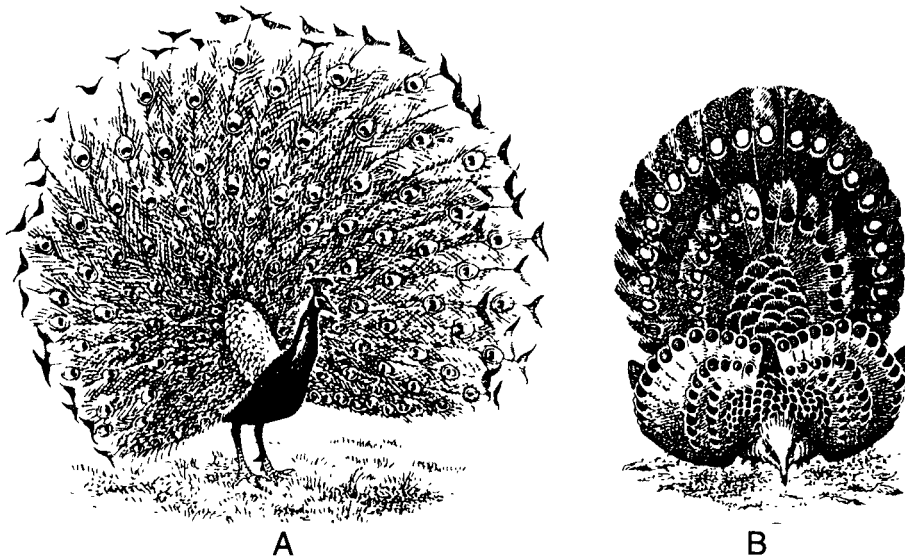

Fig. 26. Courtship behaviour : A. Common peacock, B. Burmese peacock.

## 29. Territorial Behaviour in Birds

### Comments :

In 1941, **Nice** divided the territories of birds into 6 types.

- (1) **First type** of territory is very wide and it is the place of all feeding and reproductive behaviour including of pairing and sexual display.
- (2) **Second type** of territory is used only for reproductive behaviour, it is used by grebes, surans, swallows and some sparrows.
- (3) **Third type** of territory is used for display grounds by grouse, manakins and Prairie hen.
- (4) **Fourth type** of territory is used for reproductive behaviour and it is extremely small in size. It consists of nests and immediate surroundings. It includes social weavers, penguins, pelicans and monk parakeets.
- (5) **Fifth type** of territory consists of separate nesting and food gathering areas. This territory is shown by seaside sparrow and rock thrush.
- (6) **Sixth type** of territory is occupied by non-migratory birds and that is only for breeding season.

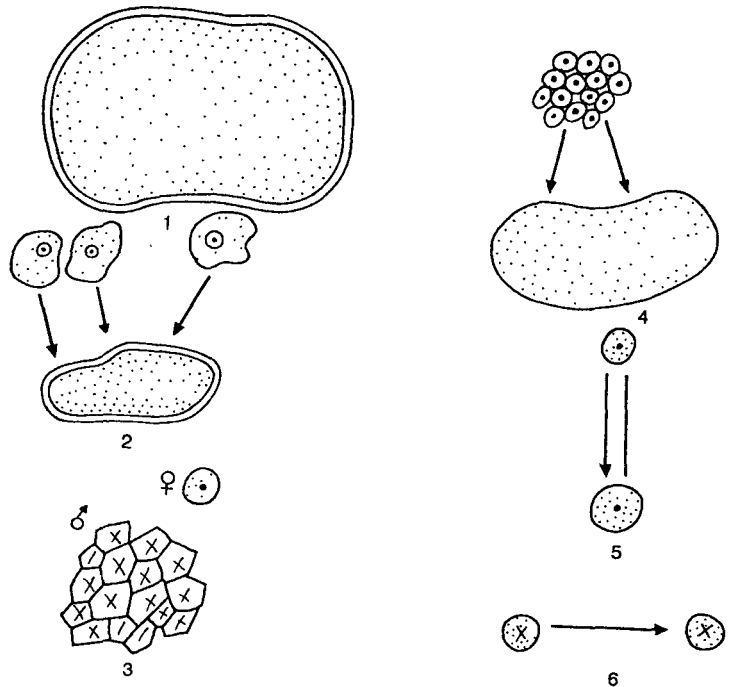

Fig. 27. Territorial behaviour of birds.

## B. PHOTOTAXIS OR PHOTORECEPTION AND TOXICOLOGICAL RESPONSES

Phototaxis and photoreception exercise, could be done with earthworms or frogs while toxicological responses could be studied with fishes using any pollutant like cadmium acetate.

### 30. Phototaxis/Photoreception Behaviour of Earthworms

Phototaxis i.e. attraction towards light in darkness is well known phenomenon for insects. Other animals also show phototaxis or photoreceptor. Phototaxis can be observed on earthworms in rainy season when earthworms are available in large number.

#### Procedure :

- (1) Make a rectangular 12" × 6" wooden box with a partition in the center. The base of the box should be sliding and the partition should be made such, as to allow only earthworms to wriggle from one chamber to another. One chamber should be completely dark and in another chamber fix a small zero watt white bulb with a small glass window in the chamber with bulb.
- (2) Keep the box on experimental table and slide the base of wooden box closer towards you, keep 25 earthworms in the dark side of the box, push the base to close it and switch on the bulb and observe. Observe the movement of earthworm through a glass window. Earthworms are attracted towards the lighted chamber, this reveals phototaxis in earthworm.

### 31. Toxicological Response of Fish : Operculum Movement and Surfacing

In fishes movement of operculum and surfacing (emergence of fish on the surface of water) is interesting behaviour of the fishes to be observed. Movement of operculum and emergence depend on conditions of water, such as dissolved oxygen, dissolved toxicological substances such as cadmium acetate, zinc, lead etc. The following experiment has been designed using cadmium acetate as a heavy metal toxicant.

**Procedure :** Cadmium acetate, distilled water, two large glass troughs and a medium size living fish are required for the experiment.

- (1) Take two glass troughs, label them as A and B.
- (2) In glass trough A fill it with water upto 3/4 label. Keep glass trough on the laboratory table. Observe the movement of fish and also the movement of operculum in one minute and emergence of fish on the surface of water. In case of common aquarium Gold fish the movement of operculum is 60 to 61 per minute and surfacing 6 to 7 times in 5 minutes. Take at least 5 readings and calculate the average value.
- (3) Take glass trough B for studying toxicological responses. First determine LD<sub>50</sub>. In case of cadmium acetate prepare LD<sub>2</sub> solution. Fill the glass trough with cadmium acetate solution and leave a fish in it. Observe the movement of operculum and surfacing of fish in one minute and five minutes respectively. Take 5 readings and calculate the average value.

**Precautions :** The above experiment must be done with concentration and care.

# 19

## Viva-Voce Questions

### QUESTIONS & ANSWERS

(Questions are asked from the students and answers should be addressed to the teachers)

#### Question

**Q. 1. What do you mean by the word chordata ?**

**Ans.** Sir, In Greek literature *chorda* means a string and in Latin literature *chordatus* means a chord. Both string and chord point out towards **Notochord**.

**Q. 2. What are three basic chordata characters ?**

**Ans.** Sir, All chordates show, the presence of the following 3 basic characters at some stage of their life-cycle.

- (1) Notochord
- (2) Nerve cord
- (3) Pharyngeal gill-slits

**Q. 3. How will you classify chordates ?**

**Ans.** Sir, All the chordates are classified into 2 groups :

- (1) **Acraniata** or lower chordates or protochordates. In this group cranium

or brain box is absent. Exclusively marine they contain urochordates and cephalochordates.

- (2) **Cranita** or higher **chordates**—This includes animals with well developed **cranium** and the notochord is broken into smaller pieces called **vertebrae**. Hence this group is called as vertebrate.

**Q. 4. How will you further classify craniates ?**

**Ans.** Sir, Higher chordates are divided into two divisions.

**Division 1. Agnatha** 1. Without jaws and paired appendages. It includes extinct fishes ostracoderms and living fishes without jaws such as *Petromyzon*.

**Division 2. Gnathostomata**—with true jaws and paired appendages. It includes all vertebrates Fishes, Amphibians. Reptiles, Birds and Mammals.

**Q. 5. Give specific characters of the following**

- I. Superclass—Pisces
- II. Superclass—Tetrapoda
- III. Class—Amphibia
- IV. Class—Reptilia

**V. Class—Aves or birds****VI. Class—Mammalia**

**Ans.** Sir, Super class—Sir, pisces are characterized by having **paired fins, paired gills**, and skin with **dermal scales**.  
**II-Super-class—tetrapoda** Sir, They are characterized by having **paired limbs** (Forelimbs and hind limbs).  
**III-Class—Amphibia—Sir**, They are characterised by having amphibious life and skin without scales. As in case of frog life-cycle includes embryonic, and larval stages in water. Adults are adapted to live in water as well as land.

**CLASS REPTILIA**

**Sir**, Reptiles are characterised by having dry skin with **epidermal scales**. They have single occipital condyle, bony skeleton and internal fertilization.

**CLASS AVES OR BIRDS**

**Sir**, Birds are **feathered bipeds**. Forelimb is modified into feather. Bones pneumatic for providing lightness to the body. Animals with single occipital condition and warm blood are adapted for aerial mode of life and having flight habits. Pigeon and parrot. Heart 4-chambered.

**CLASS MAMMALIA**

Mammals are characterized by having **mammary glands, hairs** and **2 occipital condyle**. They are warm blooded with 4-chambered heart.

**Q. 6.** What do you know about primitive and specialized characters of *Amphioxus*.

**Ans.** Sir, *Amphioxus* is a simplest chordata having both primitive and specialized characters.

**Sir**, the primitive characters are as under.

- (1) Rod like notochord extending into snout.
- (2) Absence of jaws and paired fins.
- (3) Segmented myotomes, straight intestine and ciliary mode of feeding the specialized characters are :  
Elaborate velum, oral hood and several gill-slits.

**Q. 7.** What are reduced and degenerate characters ?

**Ans.** Sir, Reduced brain and sense organs are degenerate characters.

**Q. 8.** What is zoological name of Hammer headed fish ?

**Ans.** Sir, It is *Sphyrna* or *Zygena*.

**Q. 9.** What do you about Torpedo ?

**Ans.** Sir, It is electric fish. In this fish adductor mandibulate and constrictor muscles are modified to form two electric organs and innervated by VII, IX and X cranial nerves. Electric organs are composed off hexagonal cells called as **Electroplexes**. Electric current of 50 to 60 mv are generate to paralyse the enemites or fishermen. Electric organs are offensive and defensive organs.

**Q. 10.** What is special feature of *Chamaeleon* ?

**Ans.** Sir, It is colour changing of animal.

**Q. 11.** Name few non-poisonous shakes.

**Ans.** Sir, *Typhlops* (blind snake), *Uropeltis*, *Eryx* and *Python* are non-poisonous snakes.

**Q. 12.** Is hydrophis poisonous or non-poisonous snake.

**Ans.** Sir, Hydrophis is poisonous snake.

**Q. 13.** Name five poisonous snakes.

**Ans.** Sir, *Bungarus*, *Naja naja*, *Hydrophis*, Russel's viper and pit viper (*Ancistrodori*).

**Q. 14.** What are the characters of a poisonous snakes ?

**Ans.** Sir, Poisonous snakes are characterised by having complete or partial scales, presence of hypophyses and presence of fangs.

**Q. 15.** Which one is deadly poisonous snake?

**Ans.** Sir, Cobra (*Naja naja*) is deadly poisonous snake.

**Q. 16.** What is special feature in the hood of cobra.

**Ans.** Sir, In expanded hood peculiar **binocellate** mark is present on dorsal surface.

**Q. 17.** How *Crocodyle*, *Alligator* and *Gavialis* differ from each other.

**Ans.** Sir, the snout of *Crocodyle* is long and pointed, in *Alligator* short and broad while in *Gavialis* snout is elongated.



**Q. 18.** What do you know about limbless amphibian ?

**Ans.** Sir, *Ichthyophis* is limbless amphibia commonly called as *Caecilians*.

**Q. 19.** Can you enumerate primitive amphibian and specialized characters of *Ichthyophis*?

### PRIMITIVE CHARACTERS

**Ans.** Sir, Primitive characters include dermal scales, in the skin, number of dermal bones is skull.

Advanced characters : it has 3-chambered, heart, urinogenital system and brain like Amphibia.

Specialized characters : loss of limbs, short post anal part and copulatory organs.

**Q. 20.** What is zoological name of mud puppy ?

**Ans.** Sir, It is *Necturus*.

**Q. 21.** What is Tuatara and what do you know about it ?

**Ans.** Sir, *Sphenodon* is called as Tuatara. It is a living fossil. It has several primitive characters such as 2-temporal fossa amphicentroid vertebrae, pineal eye, vomerine teeth and absence of copulatory apparatus in males.

**Q. 22.** Which one of the following is adapted for desert life *Phrynosoma* or *Hemidactylus* ?

**Ans.** Sir, *Phrynosoma*.

**Q. 23.** Which dinosaur measured about approximately 20 metres in length and 50 tons in weight ?

**Ans.** Sir, *Brontosaurus*.

**Q. 24.** Which dinosaur is called as Animate engine of destruction ?

**Ans.** Sir, It is *Tyrannosaurus*. The dinosaur measured approximately 15 metres in length, 6 meters in height. It had small forelimbs and dagger-like teeth by which it used to tear off the body of prey.

**Q. 25.** What is most important feature of birds ?

**Ans.** Sir, Feathers. They are defined as feathered bipeds.

**Q. 26.** What do you know about *Archaeopteryx*?

**Ans.** Sir, *Archaeopteryx* is fossil bird which serves as connecting link between reptiles and birds. It has both reptilian and avian characters.

**Q. 27.** Can you enumerate reptilian and avian features of *Archaeopteryx*.

**Ans.** Sir, Reptilian features are :

- (1) Epidermal scales, jaw like teeth in beak.
- (2) Amphicoelus vertebrae.
- (3) Carpals and metacarpals.

**Avian characters are :**

- (1) Forelimbs modified into feathers or wings.
- (2) Beak jaw like.
- (3) Bones and girdles avian like. Clavicles fuse to form V-shaped bone.
- (4) Foot consists of tarsometatarsus.

**Q. 28.** What are different types of feet are found in birds ?

**Ans.** Sir, Feet are modified and adapted for cursorial or running, majority for perching, scratching, raptorial, wading, swimming, climbing and clinging.

**Q. 29.** What are different types of beak in birds ?

**Ans.** Sir, Beaks are adapted for different purposes. Such as seed-eating, cutting, insectivorous, water and mud straining, fish catching and flour probing.

**Q. 30.** Which bird Darwin used to explain for sexual selection ?

**Ans.** Sir, *Columba livia*.

**Q. 31.** Which bird was used by Camillo Golgi ?

**Ans.** Sir, Barn owl.

**Q. 32.** What is the zoological name of our national bird ?

**Ans.** Sir, *Pavo cristatus*.

**Q. 33.** What are zoological names of crow and parrot ?

**Ans.** Sir, *Corvus splendens* and *Psittacula* respectively.

**Q. 34.** What is common name of *Eudynamis scolopaceus* ?

**Ans.** Sir, It is koel.

**Q. 35.** Can you enumerate economic value of birds ?

**Ans.** Sir, Birds are economically important in following ways :

- (1) They provide food and animal proteins. Chickens, poultry birds/have given rise to poultry industry.

- (2) Birds provide amusements. Childrens are fascinated by birds.  
 (3) Birds are associated with sports industry in making shuttle cocks.

**Q. 36. What are important characters of class mammalia ?**

**Ans. Sir,** Mammals have following important features.

- (1) Presence of mammary glands. In females mammary glands are well developed for feeding young ones (infants).
- (2) Body covered by hairs.
- (3) External ear or pinna present.
- (4) Warm blooded and high metabolism.
- (5) 7 cervical vertebrae and 2 occipital condyl.

**Q. 37. Classify mammals into sub-classes.**

**Ans. Sir,** Sub-class A–Prototheria–Egg laying  
 Sub-class B–Allotheria–Extinct mammal  
 mammals Sub-class C–Theria–Includes  
 Marsupials and Egg-laying mammals.

**Q. 38. What are special features of Duck-bill platypus ?**

**Ans. Sir,** Duck-bill platypus has following features.

- (1) It is egg laying mammal.
- (2) It shows reptilian, mammalian and intermediate features.

**Q. 39. Enumerate reptilian and mammalian features of platypus.**

**Ans.** (1) Reptilian features–Urinogenital system, precoracoids, absence of pinna and corpus callosum like reptiles  
 (2) Presence of hair, diaphragm, 3 ear ossicles and 4-chambered heart like mammals.

## FIXATIVES AND STAINS

**Q. 40. Can you tell different fixatives ?**

**Ans. Sir,** Bouin's fluid (alcoholic and aqueous) formaline and currosive sublimate are few fixatives.

**Q. 41. When currosive sublimate is used ?**

**Ans. Sir,** It is used in case of fixing for whole mounts such as *Daphnia* or *Nereis* parapodia.

**Q. 42. What fixative is used for cytological studies or for chromosomes ?**

**Ans. Sir,** Carnoy's fluid consisting of glacial acetic acid 1 part and absolute alcohol 3 parts.

**Q. 43. What are the functions of a fixative agent.**

**Ans. Sir,** A fixative agent has following functions.

- (1) It makes the tissue hard and the hardening prevents any further post-mortem changes.
- (2) Fixative agent coagulates chemical elements which are not washed away during processing of tissues for staining etc.
- (3) Fixative agents render in soluble various elements of cells. It alters their refractive indices and makes them optically active so that their structures may be seen under microscope.

**Q. 44. Can you enumerate different stains ?**

**Ans. Sir,** Different stains are Borax-carmine, Haematoxylin Eosine Janus green B, Neutral red and Methylene blue.

**Q. 45. What do you mean by cytoplasmic and nuclear stains ?**

**Ans. Sir,** Nuclear stains such as Haematoxylin stains **nucleus** while Eosin stains cytoplasm. Haematoxylin gives blue colour while eosin or another cytoplasmic stain Borax-carmine renders pink or red colour.

**Q. 46. What do you mean by dehydration ?**

**Ans. Sir,** Removal of water gradually from tissues is called as dehydration.

**Q. 47. What is you utility of dehydration ?**

**Ans. Sir,** Water invites viral or bacterial infections which cause decay of tissues. Alcohol prevents decay.

**Q. 48. What is de-alcoholization ?**

**Ans. Sir,** Removal of alcohol from tissue is called as de-alcoholization or **clearing**.

**Q. 49. What is composition of neural complex is *Herdmania* ?**

**Ans. Sir,** Neural complex of *Herdmania* is made up of neural gland, nerve ganglion and dorsal tubercle.

**Q. 50. What are 3 types of spicules is *Herdmania*.**

Ans. Sir, In *Herdmania* spicules are Microscleres, pipette-shaped megascleres and spindle shaped megascleres.

**Q. 51. In which animal do you find oral hood and velum ?**

Ans. Sir, In *Amphioxus*.

**Q. 52. In which of the following fishes you find cycloid scale, ctenoid scale, placoid scale and ganoid scale.**

Ans. Sir, Cycloid scales are found in *Labeo* and lung-fishes, ctenoid scale in *Nandus*, placoid scale in *Scoliodon* and Ganoid scale is *Polypterus*.

**Q. 53. In frog V. S. of skin which layer is found between stratum spongiosum and stratum compactum.**

Ans. Sir, Cellular layer.

**Q. 54. In a T. S. passing through stomach what different layers are found ?**

Ans. Sir, Different layers in T.S. of stomach consists of serosa, longitudinal muscle layer, circular muscle layer, sub-mucosa, muscularis mucosa and mucosa. Mucosa contains villus processes.

**Q. 55. Describe T.S. of liver of Frog ?**

Ans. Sir, Amphibian liver in dark chocolate coloured. T.S. of liver shows that it is made up of rounded hepatic lobules. Each lobule contains 5-10 hepatic cells. Portal tract is made up of portal vein, afferent blood vessel and hepatic artery. It also contains bile duct.

**Q. 56. Can you enumerate functions of liver ?**

Ans. Sir, Liver has following functions :

- (1) It stores glycogen.
- (2) It secretes bile juice, bile salts, cholesterol.
- (3) It produces fibrinogens and prothrombin.
- (4) Kupffer cells present perform phagocytic activities.
- (5) Liver changes ammonia into urea by Ornithine cycle.

**Q. 57. How would you account that pancreas is both exocrine and endocrine ?**

Ans. Sir, Exocrine secretions consists of digestive enzymes such as amylase, trypsin and

lipase. Islets of Langerhans performs endocrine activity. It contains  $\beta$ -cells and  $\alpha$ -cells which secrete **Insulin** and **Glucagon** hormones.

**Q. 58. How Insulin and Glucagon control carbohydrate metabolism ?**

Ans. Sir, Insulin regulates blood sugar level and its deficiency causes **diabetes**. Glucagon increases blood sugar level and its deficiency causes **hypoglycemia**.

**Q. 59. What do you know about structure and functions of spleen of frog ?**

Ans. Sir, Spleen consists of fibrous capsule, trabecules, red pulp and white pulp along with blood vessels. Spleen, is one of the important lymphoid organ. It contains macrophages, T-lymphocytes, B-lymphocytes and Leucocytes. Macrophage, B-lymphocytes and T-lymphocytes eliminate foreign antigens.

**Q. 60. Describe structure of kidney observed in a transverse section.**

Ans. Sir, T.S. passing through kidney shows that it is made up of nephrostomes, uriniferous tubules and Bowman's capsule containing glomerulus.

**Q. 61. Describe different layers in a T.S. of adrenal gland of Rabbit.**

Ans. Sir, T.S. passing through Adrenal gland shows **cortex** and **medulla**. Cortex is further divided into a capsule, zona-glomerulosa, zona reticularis and medulla. Medulla has irregularly disposed cells.

**Q. 62. Tell hormones secreted by medulla and cortex along with their functions.**

Ans. Sir, Medullary hormones are **Epinephrine** and **Norepinephrine**. Epinephrine promotes glycogenolysis and increases blood pressure. Cortical region secretes corticoids such as glucocorticoids which promote gluconeogenesis and protein metabolism.

**Q. 63. What are various stages in spermatogenesis ?**

Ans. Sir, Different stages are sperm mother cell, primary spermatocytes, secondary spermatocytes, spermatids and sperms.

**Q. 64. What do you know about corpus luteum ?**

**Ans.** Sir, After extrusion of ova, yellowish mass left in called **corpus luteum** which produces a hormone called progesteron. This hormone facilitates implantation of fertilized ovum in uterus.

**Q. 65. Tell the structures found in a T.S. of mammalian liver.**

**Ans.** Sir, T.S. passing through lower shows that it is made up of hepatic lobules. Each lobule contains central vein, bile duct and **radiating column** of hepatic cells. Spaces between hepatic strands is called sinusoids. Hepatic cells or liver cells contain phagocytes cells called as Kupffer cells.

**Q. 66. Enumerate functions of liver.**

**Ans.** Sir, (1) Glycogenesis and gluconeogenesis take place in liver.  
(2) Liver produces blood clotting factors and components such as **fibrinogen, prothrombin** and **heparis**.  
(3) It controls sugar and protein metabolism.  
(4) It stores and synthesizes vitamins.

**Q. 67. What do you know about Thyroxin ?**

**Ans.** Sir, Thyroxin hormone is produced by thyroid gland. **Thyroxin** controls metabolism, Hyper thyrodism causes protrusion of eye balls.

**Q. 68. What is function of parathormone.**

**Ans.** Sir, Parathormone controls concentration of calcium and phosphate in plasma.

**Q. 69. Enumerate structures seen in a V. S. of mammalian skin.**

**Ans.** Sir, Different structures are stratum corneum, stratum granulosum, dermis, sweat gland, epidermis hair, hair fossicle and sebecious gland.

**Q. 70. What are main functions of a mammalian skin ?**

**Ans.** Sir, It has following functions.  
(1) It protects the body providing **first time of immunological defense**.  
(2) Mammary glands produces milk.  
(3) It prevents loss of water.  
(4) It performs excretory function-various excretory products are passed out as sweat.

**Q. 71. Which hormone is secreted by gastric gland ?**

**Ans.** Sir, **Gastrin** which stimulates gastric glands to secrete digestive juice.

**Q. 72. In mammalian kidney where do you find Bowman's capsule.**

**Ans.** Sir, cortex.

**Q. 73. Crypts of Lieberkuhn and Brunner's glands are found in ilium of rabbit or frog.**

**Ans.** Sir, Ilium of Rabbit.

## EMBRYOLOGY SLIDES

**Q. 74. What do you mean by indeterminate development ?**

**Ans.** Sir, When the fate of blastomeres is fixed at gastrula stage, then it is called as indeterminate development.

**Q. 75. In which groups you find indeterminate development ?**

**Ans.** Sir, In all deuterostomes-Echinoderms and all chordates.

**Q. 76. What is holoblastic cleavage ?**

**Ans.** Sir, When dividing line passes from one pole to other, it is called as holoblastic cleavage.

**Q. 77. In chick after how many hours of incubation you find primitive streak well developed.**

**Ans.** Sir, After 17 hours of incubation.

**Q. 78. In case of chick embryo after 18 hours of incubation, can you tell us about division of brain.**

**Ans.** Sir, Brain is divided into prosencephalon, (fore brain), mesencephalon (mid-brain) and rhombencephalon (hind brain).

## OSTEOLOGY

**Q. 79. In scoliodon what kind of skeleton you find ?**

**Ans.** Sir, Cartilaginous.

**Q. 80. What is pre-zygapophysis ?**

**Ans.** Sir, It is articular facet by which vertebrae articulate with each other.

**Q. 81. Acetabulum is found in pelvic or pectoral girdle.**

Ans. Sir, In Pelvic girdle.

**Q. 82. What is dermocranium ?**

Ans. Sir, Dermal bones of skull are called as dermocranium.

**Q. 83. What are different types of suspensorium ?**

Ans. Sir, Suspensorium are (1) **Amphistylic**– It is double suspension. Upper jaw is directly attached to otic region of cranium and hyomandibular cartilage is movably attached to the otic region.  
(2) **Autodiastylic**. It was found in extinct fishes in which upper jaw was attached to cranium by ligaments.  
(3) **Autostylic**. When upper jaw fuses with cranium. It is further divided in four types.

**Q. 84. Skulls of frog and rabbit are monocondylic or dicondylic.**

Ans. Sir, Dicondylic.

**Q. 85. In skull of frog occipital region is made up which bones.**

Ans. Sir, Exoccipitals.

**Q. 86. In rabbit occipital region is made up of which bones.**

Ans. Sir, Two exoccipitals, one basi-occipital and one supraoccipital.

**Q. 87. What is the function of columella auris in frog ?**

Ans. Sir, To conduct sound vibrations upto inner ear located inside auditory capsule.

**Q. 88. Which vertebrae in frog has biconvex centrum ?**

Ans. Sir, Ninth vertebra.

**Q. 89. In which vertebra in the case of *Varanus* centrum and transverse processes are absent.**

Ans. Sir, Atlas or first vertebra.

**Q. 90. In which group you find synsacrum.**

Ans. Sir, In birds.

**Q. 91. What is merrythought or wish bone ?**

Ans. Sir, Furcula of pectoral girdle of fowl is called as wish bone. You take the bone in hand and wish your ideas to be fulfilled. This bone also denotes sign of victory.

**Q. 92. In which group you find pneumatic bones.**

Ans. Sir, In birds.

**Q. 93. What do you mean by renal portal system ?**

Ans. Sir, The double system of filtration one in leg and another in kidney is called as **renal portal system**. The femoral vein consisting of renal portal vein and pelvic vein along with sciatic veins forms renal portal system. The renal portal consists of 4 to 5 pairs of renal veins.

**Q. 94. What is hepatic portal system ?**

Ans. Sir, The blood vessels collecting blood from alimentary canal (stomach, intestine, ilium, duodenal pancreatic vessels) and communicating constitute hepatic portal system. Hepatic portal system communicates with liver.

**Q. 95. How many cranial nerves are present in frog ?**

Ans. Sir, 10 pairs.

**Q. 96. Why they are called as cranial nerves?**

Ans. Sir, Because these nerves arise from cranium.

**Q. 97. What do you know about biting mechanism of snake ?**

Ans. Sir, In biting mechanism two main steps are involved :

- (1) Erection of fang and
- (2) Injection of poison into victim's body.

**Q. 98. Name the animals other than bird which show arrial or flying adaptations.**

Ans. Sir, the following animals show aerial adaptations.

- (1) *Exocoetus* (flying fish).
- (2) *Rhacophorus* (Flying frog).
- (3) *Draco* (Flying lizard).
- (4) *Cynopterus*.

**Q. 99. What do you know about role of pituitary for controlling the body ?**

Ans. Sir, pituitary gland is called as master gland as its secretion controls the functioning of other endocrine glands. Some of its hormones are (follicle stimulating hormone) (FSH) (Thyroid stimulating hormone) (TSH), (Somatotrophic hormone) SH, (Adenocorticotropic hormone) (ACTH) and (melanocyte stimulating hormone) (MSH).

**Q. 100. From pancreas which hormones are secreted by  $\alpha$  and  $\beta$  cells.**

Ans. Sir,  $\alpha$ -cells secrete insulin and  $\beta$ -cells glucagon. These hormones control glucose metabolism.